



**MOTOROLA**

SGE73/D  
REV 7

**MOTOROLA SEMICONDUCTOR**

# **MASTER SELECTION GUIDE**

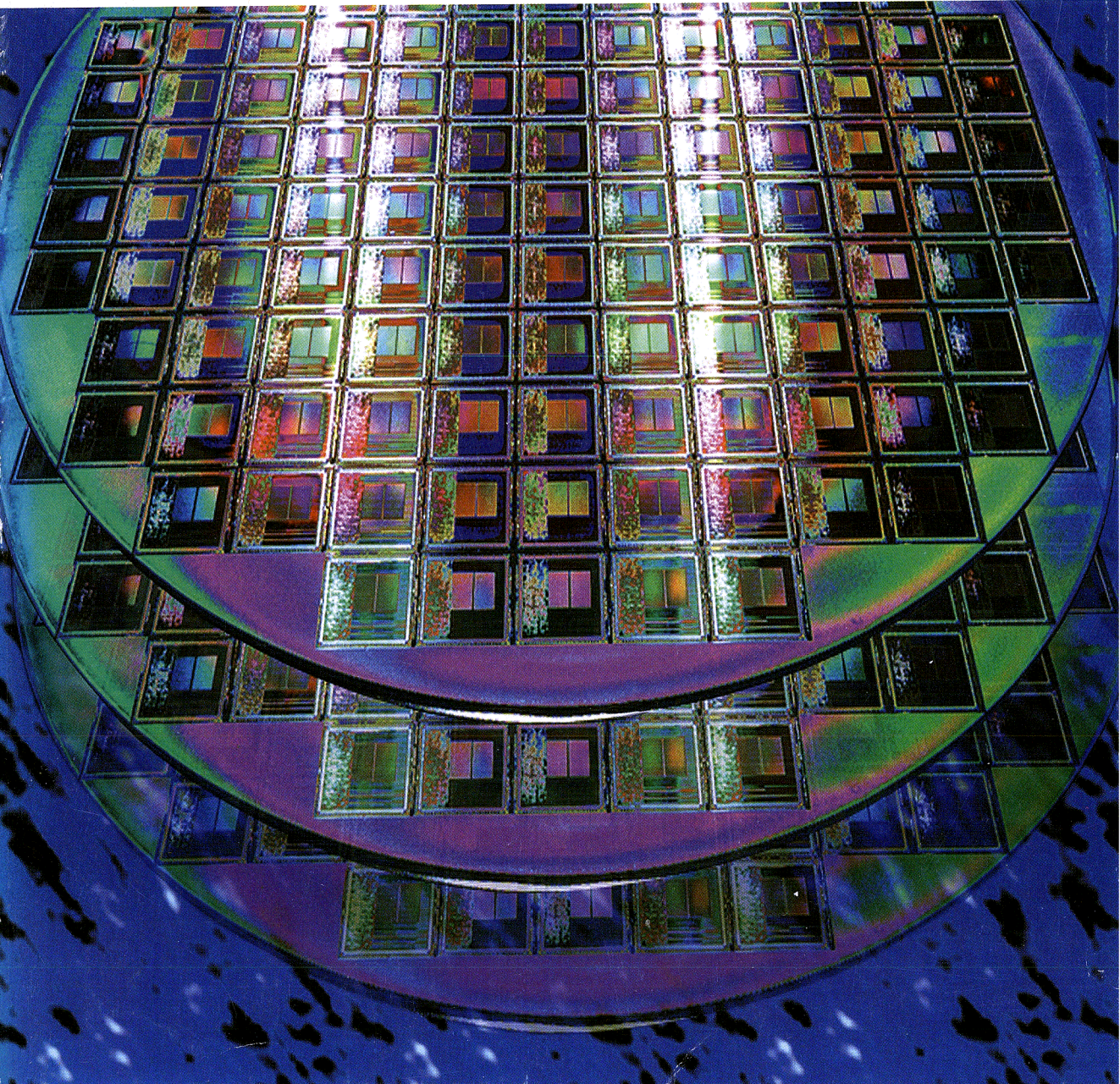







## Introduction

---

**Semicustom Application Specific  
Integrated Circuits (ASIC) 1**

---

**Microcomputer Components 2**

---

**TTL, ECL, CMOS and  
Special Logic Circuits 3**

---

**Linear and Interface  
Integrated Circuits 4**

---

**Discrete Products 5**

---

**Military Integrated Circuits  
and Discrete Products 6**

---

**Product Literature and  
Technical Training 7**

---

**Device Index and  
Subject Index 8**

---

**Sales Offices  
and Distributors 9**









# **MOTOROLA**

## **Master Selection Guide**

---

The information in this book has been carefully checked and is believed to be accurate; however, no responsibility is assumed for inaccuracies. Furthermore, this information does not convey to the purchaser of semiconductor devices any license under the patent rights to the manufacturer.

Motorola reserves the right to make changes without further notice to any products herein. Motorola makes no warranty, representation or guarantee regarding the suitability of its products for any particular purpose, nor does Motorola assume any liability arising out of the application or use of any product or circuit, and specifically disclaims any and all liability, including without limitation consequential or incidental damages. "Typical" parameters can and do vary in different applications. All operating parameters, including "Typicals" must be validated for each customer application by customer's technical experts. Motorola does not convey any license under its patent rights nor the rights of others. Motorola products are not designed, intended, or authorized for use as components in systems intended for surgical implant into the body, or other applications intended to support or sustain life, or for any other application in which the failure of the Motorola product could create a situation where personal injury or death may occur. Should Buyer purchase or use Motorola products for any such unintended or unauthorized application, Buyer shall indemnify and hold Motorola and its officers, employees, subsidiaries, affiliates, and distributors harmless against all claims, costs, damages, and expenses, and reasonable attorney fees arising out of, directly or indirectly, any claim of personal injury or death associated with such unintended or unauthorized use, even if such claim alleges that Motorola was negligent regarding the design or manufacture of the part. Motorola and  are registered trademarks of Motorola, Inc. Motorola, Inc. is an Equal Opportunity/Affirmative Action Employer.

© Motorola, Inc. 1994  
Previous Edition © 1993  
"All Rights Reserved"  
Printed in U.S.A.



ALEXIS, Buffalo, Bullet-Proof, BurstRAM, CDA, CMTL, Ceff-PGA, Customer Defined Array, DECAL, Designer's, DIMMIC, DSPRAM, ECLinPS, ECLinPS LITE, ECL300, E-FETs, EpiBase, Epicap, FIRsT, GEL-PAK, GEMFET, HDC, HDTMOS, H4C Series, H4C Plus, HYPERformance, ICePAK, L<sup>2</sup>TMOS, MAACPAC, MCML, MDTL, MECL, MECL 10K, MECL 10H, MECL III, MEGAHERTZ, MCCS, Media Engine, Memorist, MHTL, MicroCool, MicroSIMM, MiniMOS, MONOMAX, MOSAIC I, MOSAIC II, MOSAIC III, MOSAIC IV, MOSAIC V, MOSFET, Mosorb, MRTL, MTTL, Multi-Pak, MUSCLE, Mustang,  $\mu$ SIMM, OACS, OnCE, PHACT, Predix, PowerBase, POWER OPTO, POWER TAP, PRISMCard, QUIL, Rail-To-Rail, SCANSWITCH, SENSEFET, SLEEPMODE, SMARTDISCRETES, SMARTMOS, SMARTswitch, SORF, Surmetic, SWITCHMODE, Symmetric Superscalar, TestPAS, Thermopad, Thermopad II, Thermowatt, Unibloc, UNIT/PAK, X-Ducer, Z-Switch and ZIP R TRIM are trademarks of Motorola, Inc.

C-QUAM, MOSAIC, TMOS and ZIP-R-TRIM are a registered trademark of Motorola, Inc.

Apollo is a registered trademark of Hewlett Packard Inc.

AutoLogic, NetEd, QuickSim II, QuickPath and Falcon Framework are trademarks of Mentor Graphics Corp.

Concept, Gate Ensemble, Verilog-XL, Veritime and Dracula are trademarks of Cadence Design Systems, Inc.

Daisy is a trademark of Daisy Systems Corporation.

DDCMP and VAX are trademarks of Digital Equipment Corporation.

Design Compiler, HDL Compiler, Test Compiler and DesignWave are trademarks of Synopsys, Inc.

Echelon, LON and NEURON are registered trademarks of Echelon Corporation.

ETHERNET is a trademark of Xerox Corporation.

FACT and FAST are trademarks of National Semiconductor Corporation.

FIDE is a trademark of Apronix.

GED is a trademark of Valid Logic Systems Inc.

HP/Apollo is a registered trademark of Hewlett-Packard Inc.

i486 and Pentium are registered trademarks of Intel Corporation.

InterTools is a trademark of Intermetrics, Inc.

IBM, IBM PC, PowerPC and SDLC are trademarks of International Business Machines Corporation.

Isotop is a trademark of SGS-Thomson Microelectronics.

LONBUILDER, LONTALK and LONWORKS are trademarks of Echelon Corporation.

Macintosh is a trademark of Apple Computer, Inc.

Mentor Graphics is a trademark of Mentor Graphics Corporation.

MOTIVE is a registered trademark of Quad Design.

NeXT is a trademark of NeXT Computer, Inc.

ROM68K and SmartROM are trademarks of Integrated Systems, Inc.

SPARC is a trademark of SPARC International, Inc.

Sun-4 is a trademarks of Sun Microsystems Inc.

Thermal Clad is a trademark of the Bergquist Company.

UNIX is a registered trademark of UNIX System Laboratories, Inc.

*All brand names and product names appearing in this document are registered trademarks or trademarks of their respective holders.*

# Master Selection Guide

---

## Where We Stand . . .

### Total Customer Satisfaction

Service, speed and facility of response, product quality and reliability are the goals to which we are dedicated. Our commitment to progress such as Six Sigma performance and Cycle Time Reduction are symbolic of a culture in which Total Customer Satisfaction is, overwhelmingly, our primary objective.

In today's highly competitive market, selecting the most effective semiconductor components for a given application poses a significant challenge. The range of available functions and the sheer number of components within each unique product line is staggering. Add to this the number of vendors capable of satisfying a portion of the overall system demands and the selection of a cost-effective component complement can be as time consuming as the design of the system itself.

This is where Motorola occupies a unique position among semiconductor manufacturers – one that can significantly shorten the product selection cycle. Please consider these facts:

As a manufacturer of semiconductors since the very beginning of the technology, Motorola has emerged as a leading supplier of such components to the world market.

Motorola's product line is the *broadest* in the industry, capable of filling 75–80% of the many applications for semiconductor devices.

In each of its various product categories, Motorola is a recognized leader, with leading edge products as well as commodity products for mass applications.

Motorola's vast network of sales offices and distributors, augmented by manufacturing centers throughout the world, not only ensures easy communications, cost-effective pricing and rapid service, but guarantees a continuing stream of state-of-the-art products based on world-wide experience and demand.

## How To Use This Guide . . .

This Selection guide is arranged to provide three-way assistance to engineers and technicians in making a first-order selection of components best suited for a specific circuit or system design.

*If you have a device number that needs identification or if you want to know if Motorola manufactures a particular device type:*

1. Turn to the Device Index for a complete listing of Motorola products, and the page numbers where more detailed information is given for these products.

*If you have a device name or acronym and wish to know if Motorola makes such a device:*

2. Look for it in the Subject Index.

*If you want an overview of Motorola products for a specific product category:*

3. Refer to the quick-reference product line guide located at the front of this publication or use the table of contents located at the front of each section.

### Telephone Assistance, North America Only

For literature requests or general product information, call toll-free any weekday, 8:00 a.m. to 4:00 p.m., MST.

To order technical literature by specific document title, i.e., SGXX/D or DLXXX/D, or by part number only, call

**1-800-441-2447**

### Non-North American Locations

Please contact your local Motorola Sales Office or Authorized Distributor.

# Table of Contents

## Semicustom Application Specific Integrated Circuits 1.0–1

ASIC Preview	1.1–1
Bipolar	1.1–1
ECL & ETL Series Arrays	1.1–1
CMOS	1.1–1
1.0 Micron HDC Series	
Sub-Micron H4C & H4CPlus Series	1.1–1
Design Automation Software (OACS™)	1.1–1
Advanced Packaging	1.1–1
Architecture for the 90's CDA™	
(Customer Defined Arrays)	1.1–1
CDA — The Architecture of the '90s	1.1–1
Bipolar ECL & ETL Series Arrays	1.1–2
Third Generation	1.1–2
ETL Series Arrays Extend Design Flexibility	1.1–2
ETL Series Features Mixed ECL–TTL Interface	1.1–2
CMOS	1.1–3
1.0 Micron CMOS HDC™ Series	1.1–3
Triple-Layer Metal	1.1–3
Sub-Micron CMOS H4C™ Series	1.1–4
CDA™ Architecture	1.1–4
Sub-Micron CMOS H4CPlus™ Series	
Mixed 3.3 V/5.0 V Levels	1.1–5
Design Automation Software	1.1–6
The Open Architecture CAD System™	1.1–6
OACS™ 2.2 and 3.1M Features	1.1–6
Advanced Packaging	1.1–7
Quad Flat Pack Molded Carrier Ring	
(QFP–MCR)	1.1–7
MicroCool™ Quad Flat Pack	1.1–7
Over-Molded Pad Array Carrier (OMPAC™)	1.1–7
Literature	1.1–8
ASIC Regional Design Centers — United States	1.1–8
ASIC Regional Design Centers — International	1.1–8

## Microcomputer Components 2.0–1

Digital Signal Processors	2.1–1
DSP56100 — 16–Bit Digital Signal Processors	2.1–2
DSP56000 — 24–Bit Digital Signal Processors	2.1–3
DSP96000 — 32–Bit Digital Signal Processors	2.1–4
DSP Peripherals	2.1–5
DSP56200 — The Cascadable Adaptive Finite	
Impulse Response Digital Filter	2.1–5
DSP56ADC16 — The Analog–To–Digital Converter	2.1–6
DSP56401 — The Digital Audio Transceiver	2.1–6
DSP Development Tools	2.1–7
Application Development Systems	2.1–7
DSP Development Software	2.1–8
Design–In Software Packages	2.1–8
C–Compiler Packages	2.1–9
C–Compiler Upgrades	2.1–9

## The M68000 Family 2.2–1

Microprocessors	2.2–2
Embedded Controllers	2.2–5
Integrated Processors	2.2–7
Coprocessors	2.2–9
DMA Controllers	2.2–9
Network Devices	2.2–9
Data Communication Devices	2.2–10
General Purpose I/O	2.2–11
Fiber Distributed Data Interface	2.2–11
Development Tools	2.2–12
Support Software	2.2–12

## The M88000 RISC Family 2.3–1

Architecture, Performance, and Software Compatibility	2.3–2
Microprocessors	2.3–2
Cache/Memory Management Units	2.3–3

## The PowerPC RISC Family

### Microprocessors 2.4–1

MPC601 RISC Microprocessor	2.4–2
MPC603 RISC Microprocessor	2.4–4

### Single-Chip Microcontrollers (MCU) 2.5–1

M68HC05 CSIC Family	2.5–2
M68HC08 Family	2.5–18
M68HC11 Family	2.5–19
Modular Microcontroller	2.5–29
The M68HC16 Family	2.5–31
The M68300 Family	2.5–36
Development Tools	2.5–39
Fuzzy Logic	2.5–43
On–Line Help	2.5–43
Third–Party Support	2.5–44

### LonWorks Products 2.6–1

NEURON CHIPS	2.6–2
LonWorks Technology Overview and Architecture	2.6–4
LonBuilder Developer's Workbench	2.6–5
LonWorks Support Tools	2.6–6
LonWorks Literature	2.6–7

### MOS Memories 2.7–1

Fast Static RAMs	2.7–2
Introduction	2.7–2
Application Specific Static RAMs	2.7–2
BiCMOS Fast Static RAMs	2.7–3
CMOS Fast Static RAMs	2.7–3
Fast Static RAM Modules	2.7–4
Dynamic RAMs	2.7–5

# Table of Contents

## Microcomputer Components (continued)

### MOS Memories (continued)

Introduction .....	2.7-5
DRAM Modules .....	2.7-5
Flash Modules .....	2.7-6
Dynamic RAMs (HCMOS) .....	2.7-6
General Memory Products .....	2.7-6
PCMCIA Flash Cards .....	2.7-7
DRAM Memory Cards .....	2.7-7

## TTL, ECL, CMOS and Special Logic Circuits ..... 3.0-1

Motorola Logic Families: Which Is Best for You? .....	3.1-3
Selection by Function	
Special Logic Circuits .....	3.1-7
Cross-Functional Tables .....	3.1-11
Numeric Listings	
Special Logic Circuits .....	3.1-22
TTL .....	3.1-26
MECL .....	3.1-34
CMOS .....	3.1-41
MECL III .....	3.1-54
HTL/DTL Circuits .....	3.1-54
Ordering Information .....	3.1-55
Case Information .....	3.1-58
Packaging Information .....	3.1-62
Surface Mount .....	3.1-62
Pin Conversion Tables .....	3.1-62
Tape and Reel .....	3.1-63
Logic Literature Listing .....	3.1-64

## Linear and Interface Integrated Circuits ..... 4.0-1

### Amplifiers and Comparators ..... 4.1-1

Operational Amplifiers .....	4.1-2
Single .....	4.1-2
Dual .....	4.1-3
Quad .....	4.1-5
High Frequency Amplifiers .....	4.1-7
AGC .....	4.1-7
Miscellaneous Amplifiers .....	4.1-8
Bipolar .....	4.1-8
CMOS .....	4.1-8
Comparators .....	4.1-9
Single .....	4.1-9
Dual .....	4.1-9
Quad .....	4.1-10

### Power Supply Circuits ..... 4.2-1

Linear Voltage Regulators	
Fixed Output .....	4.2-2

### Power Supply Circuits (continued)

Adjustable Output .....	4.2-5
Special Regulators .....	4.2-6
Switching Regulator Control Circuits	
Single-Ended .....	4.2-7
Single-Ended with On-Chip Power Switch .....	4.2-9
Double-Ended .....	4.2-10
Special Switching Regulator Controllers	
Dual Channel Current Mode .....	4.2-11
Universal Microprocessor .....	4.2-11
Power Factor Controllers .....	4.2-12
Power Supervisory Circuits	
Overvoltage Crowbar Sensing .....	4.2-14
Over/Undervoltage Protection .....	4.2-14
Undervoltage Sense .....	4.2-15
Microprocessor Voltage Regulator and Supervisory .....	4.2-16
Universal Voltage Monitor .....	4.2-16
MOSFET Drivers .....	4.2-17

### Power/Motor Control Circuits ..... 4.3-1

Power Controllers .....	4.3-2
Zero Voltage Switches .....	4.3-2
Zero Voltage Controller .....	4.3-3
High-Side Driver Switch .....	4.3-3
Motor Controllers .....	4.3-4
Brushless DC Motor Controllers .....	4.3-4
DC Servo Motor Controller/Driver .....	4.3-7
Closed-Loop Brushless Motor Adapter .....	4.3-8
Stepper Motor Driver .....	4.3-9
Universal Motor Speed Controllers .....	4.3-10
Triac Phase Angle Controller .....	4.3-11

### Voltage References ..... 4.4-1

Precision Low Voltage References .....	4.4-2
--	-------

### Data Conversion ..... 4.5-1

Data Conversion .....	4.5-2
A-D Converters .....	4.5-2
CMOS .....	4.5-2
Bipolar .....	4.5-2
D-A Converters .....	4.5-3
CMOS .....	4.5-3
Bipolar .....	4.5-3
A-D/D-A Converters .....	4.5-3
CMOS — For Telecommunications .....	4.5-3
Package Overview .....	4.5-4

### Interface Circuits ..... 4.6-1

Enhanced Ethernet Serial Transceiver (EEST) .....	4.6-2
High Performance Decoder Driver/Sink Driver .....	4.6-3
ISO 8802-3[IEEE 802.3] 10BASE-T Transceiver .....	4.6-3
Microprocessor Bus Interface .....	4.6-4



# Table of Contents

## Linear and Interface Integrated Circuits (continued)

### Interface Circuits (continued)

Address and Control Bus Extenders .....	4.6-4
Microprocessor Data Bus Extenders .....	4.6-4
Magnetic Read/Write .....	4.6-4
Single-Ended Bus Transceivers .....	4.6-5
Line Receivers .....	4.6-5
General Purpose .....	4.6-5
EIA Standard .....	4.6-5
Line Drivers .....	4.6-6
General Purpose .....	4.6-6
360/370 I/O Interface .....	4.6-6
EIA Standard .....	4.6-6
Line Transceivers .....	4.6-7
EIA-232-D/V.28 CMOS Drivers/Receivers .....	4.6-7
Peripheral Drivers .....	4.6-7
IEEE 802.3 Transceivers .....	4.6-8
CMOS Display Drivers .....	4.6-8
Package Overview .....	4.6-10

## Communication Circuits ..... 4.7-1

### RF Communications

Wideband .....	4.7-2
Wideband Single Conversion Receivers .....	4.7-2
Narrowband Single Conversion Receivers .....	4.7-2
Narrowband Dual Conversion Receivers .....	4.7-2
Transmitter .....	4.7-3
Balanced Modulator/Demodulator .....	4.7-3

### Telecommunications

Subscriber Loop Interface Circuits .....	4.7-7
PBX Architecture (Analog Transmission)	
PCM Mono-Circuits .....	4.7-8
Dual Tone Multiple Frequency Receiver .....	4.7-11
Crosspoint Switches .....	4.7-11
ISDN Voice/Data Circuits	
Integrated Services Digital Network .....	4.7-11
U-Interface Transceiver .....	4.7-12
S/T-Interface Transceivers .....	4.7-12
Dual Data Link Controller .....	4.7-13
Voice/Data Communication (Digital Transmission) .....	4.7-14
Universal Digital Loop Transceiver .....	4.7-14
ISDN Universal Digital Loop Transceiver II .....	4.7-15
Data Set Interface Circuit .....	4.7-15
Electronic Telephone Circuit .....	4.7-16
Audio Control Circuit .....	4.7-16
Dial Circuits .....	4.7-16
Tone Ringers .....	4.7-17
Speech Networks .....	4.7-18
Speakerphone	
Voice Switched Speakerphone Circuit .....	4.7-20
Voice Switched Speakerphone with	
$\mu$ Processor Interface .....	4.7-21
Voice Switched Speakerphone Circuit .....	4.7-22

## Communication Circuits (continued)

### Telephone Accessory Circuits

Audio Amplifier .....	4.7-24
Current Mode Switching Regulator .....	4.7-24
300 Baud FSK Modems .....	4.7-25
ADPCM Transcoder .....	4.7-25
Bit Rate Generators .....	4.7-25
Calling Line Identification (CLID) Receiver .....	4.7-26
CVSD Modulator/Demodulator .....	4.7-27
Summary of Bipolar Telecommunications Circuits .....	4.7-28

### Phase-Locked-Loop Components

PLL Frequency Synthesizers .....	4.7-30
Intended Applications .....	4.7-30
Additional Phase-Locked-Loop Functions .....	4.7-31
Package Overview .....	4.7-32

## Consumer Electronic Circuits ..... 4.8-1

Entertainment Radio Receiver Circuits .....	4.8-2
Entertainment Receiver RF/IF .....	4.8-2
C-Quam® AM Stereo Decoders .....	4.8-2
Audio Amplifiers .....	4.8-2
Audio Attenuator .....	4.8-2
Video Circuits .....	4.8-3
Encoders .....	4.8-3
Decoders .....	4.8-3
Video Capture Chip Sets .....	4.8-3
Deflection .....	4.8-3
Comb Filters .....	4.8-4
IF Circuits .....	4.8-4
Tuner PLL Circuits .....	4.8-4
Modulators .....	4.8-4
Video Data Converters .....	4.8-4
Television Subsystems .....	4.8-4
Monitor Subsystem .....	4.8-4
Sound .....	4.8-5
Miscellaneous .....	4.8-5
Circuit Descriptions and Diagrams .....	4.8-6
Remote Control Circuits .....	4.8-25
Package Overview .....	4.8-26

## Automotive Electronic Circuits .... 4.9-1

Voltage Regulators .....	4.9-2
Electronic Ignition .....	4.9-2
Special Functions .....	4.9-3

## Other Linear Circuits ..... 4.10-1

Timing Circuits	
Singles .....	4.10-2
Duals .....	4.10-2
Multipliers .....	4.10-2
Smoke Detectors (CMOS) .....	4.10-3
Package Overview .....	4.10-4

## Surface Mount Technology ..... 4.11-1

Linear and Interface .....	4.11-2
Bipolar .....	4.11-2

# Table of Contents

## Linear and Interface

### Integrated Circuits (continued)

#### Surface Mount Technology (continued)

MOS Digital–Analog .....	4.11–6
Package Overview .....	4.11–8
Analog MPQ Table .....	4.11–8
Tape and Reel .....	4.11–9

## Discrete Products ..... 5.0–1

### Small Signal Transistors, FETs and Diodes ..... 5.1–1

Bipolar Transistors .....	5.1–2
Plastic–Encapsulated Transistors .....	5.1–2
Plastic–Encapsulated Multiple Transistors .....	5.1–8
Plastic–Encapsulated Surface Mount Transistors .....	5.1–10
Metal–Can Transistors .....	5.1–17
Field–Effect Transistors .....	5.1–20
JFETs .....	5.1–20
MOSFETs .....	5.1–22
Surface Mount FETs .....	5.1–23
Tuning and Switching Diodes .....	5.1–25
Tuning Diodes — Abrupt Junction .....	5.1–25
Tuning Diodes — Hyper–Abrupt Junction .....	5.1–29
Hot–Carrier (Schottky) Diodes .....	5.1–33
Switching Diodes .....	5.1–34
Multiple Switching Diodes .....	5.1–37

### TVS/Zeners

#### Transient Voltage Suppressors

#### Zener Regulator

#### and Reference Diodes ..... 5.2–1

TVS (Transient Voltage Suppressors) .....	5.2–2
General–Purpose .....	5.2–2
Axial Leaded for Through-hole Designs .....	5.2–2
Surface Mount Packages .....	5.2–9
Overvoltage Transient Suppressors .....	5.2–15
Zener Diodes .....	5.2–16
Voltage Regulator Diodes .....	5.2–16
Notes — Axial Leaded Chart .....	5.2–20
Notes — Surface Mount Chart .....	5.2–23
Voltage Reference Diodes .....	5.2–31
Current Regulator Diodes .....	5.2–31

### Hybrid Power Module Operation .. 5.3–1

Integrated Power Stage IGBT .....	5.3–2
-----------------------------------	-------

### TMOS Power MOSFETs Products .. 5.4–1

TMOS Power MOSFETs .....	5.4–1
--------------------------	-------

### TMOS Power MOSFETs Products (continued)

TMOS Power MOSFETs Numbering System .....	5.4–2
HDTMOS™ Power MOSFETs .....	5.4–3
N–Channel .....	5.4–4
SO–8 (MiniMOS) Packages .....	5.4–4
SOT–223 Medium Power MOSFETs .....	5.4–5
DPAK .....	5.4–6
D <sup>2</sup> PAK .....	5.4–7
TO–220AB .....	5.4–8
Isolated TO–220 .....	5.4–10
TO–247 Isolated Mounting Hole .....	5.4–11
TO–264 High Power Products .....	5.4–12
TO–204AA (TO–3) Metal Packages .....	5.4–13
P–Channel .....	5.4–14
SO–8 (MiniMOS) Packages .....	5.4–14
SOT–223 Medium Power MOSFETs .....	5.4–14
DPAK .....	5.4–15
D <sup>2</sup> PAK .....	5.4–15
TO–220AB .....	5.4–16
Isolated TO–220 .....	5.4–16
TO–247 Isolated Mounting Hole .....	5.4–17
TO–204AA (TO–3) Metal Packages .....	5.4–17
Logic Level .....	5.4–18
SOT–223 Medium Power MOSFETs .....	5.4–18
DPAK .....	5.4–18
D <sup>2</sup> PAK .....	5.4–19
TO–220AB .....	5.4–19
Logic Level Power MOSFETs .....	5.4–20
ICePAK Multiple Chip Packages .....	5.4–21
Isotop Isolated SOT–227B .....	5.4–22
SMARTDISCRETES Products .....	5.4–23
TMOS V .....	5.4–24

### Bipolar Power Transistors ..... 5.5–1

Bipolar Power Transistors .....	5.5–2
Selection by Package .....	5.5–2
Plastic (Isolated TO–220 Type) .....	5.5–3
Plastic TO–220AB .....	5.5–4
Plastic TO–218 Type .....	5.5–7
Plastic TO–247 Type .....	5.5–9
Large Plastic TO–264 .....	5.5–10
Plastic TO–225AA Type (Formerly TO–126 Type) .....	5.5–10
DPAK — Surface Mount Power Packages .....	5.5–12
Metal TO–204AA (Formerly TO–3), TO–204AE .....	5.5–13
Audio .....	5.5–18
CRT Deflection .....	5.5–19

### Rectifiers ..... 5.6–1

Rectifier Numbering System .....	5.6–2
Application Specific Rectifiers .....	5.6–3
Low V <sub>F</sub> Schottky .....	5.6–3
MEGAHERTZ .....	5.6–3

# Table of Contents

## Discrete Products (continued)

### Rectifiers (continued)

SCANSWITCH .....	5.6-3
Automotive Transient Suppressors .....	5.6-3
SWITCHMODE™ Rectifiers .....	5.6-4
Surface Mount Schottky .....	5.6-4
Axial Lead Schottky .....	5.6-6
TO-220 Type Schottky .....	5.6-7
TO-218 Types and TO-247 Schottky .....	5.6-8
TO-204AA, DO-203AA and DO-203AB Schottky Metal Packages .....	5.6-9
POWERTAP II and SOT-227B Schottky .....	5.6-10
Ultrafast Rectifiers .....	5.6-11
Surface Mount Ultrafast .....	5.6-11
Axial Lead Ultrafast .....	5.6-11
TO-220 Type Ultrafast .....	5.6-12
TO-218 Types and TO-247 Ultrafast .....	5.6-13
POWERTAP II and SOT-227B Ultrafast .....	5.6-13
Fast Recovery Rectifiers/General Purpose Rectifiers .....	5.6-14

### Thyristors and Triggers ..... 5.7-1

Silicon Controlled Rectifiers .....	5.7-2
TRIACs .....	5.7-7
General Purpose .....	5.7-7
Optically Isolated TRIACs .....	5.7-16
Triac Driver/Triac Combinations .....	5.7-16
Thyristor Triggers .....	5.7-17
SIDACs .....	5.7-17
Programmable Unijunction Transistors — PUT ..	5.7-17
Silicon Bidirectional Switch (SBS) .....	5.7-17

### Optoelectronic Devices ..... 5.8-1

Optoisolators .....	5.8-2
Safety Standard Approvals for 6-Pin .....	
Optoisolators .....	5.8-2
Regulatory Approval Certification Index .....	5.8-2
VDE Approved Optoisolators .....	5.8-3
6-Pin Dual In-line Package .....	5.8-5
6-Pin Surface Mount .....	5.8-9
Small Outline — Surface Mount .....	5.8-12
POWER OPTO Isolators .....	5.8-13
Emitters/Detectors .....	5.8-14
Optointerrupters .....	5.8-15
Fiber Optic Components .....	5.8-15

### Sensors ..... 5.9-1

Pressure Sensors .....	5.9-2
Introduction .....	5.9-2

### Sensors (continued)

The Basic Structure .....	5.9-2
Motorola's Patented X-ducer .....	5.9-2
Linearity .....	5.9-3
Operation .....	5.9-3
Electrical Characteristics .....	5.9-4
Typical Electrical Characteristic Curves .....	5.9-5
Unibody Cross-sectional Drawings .....	5.9-5
Packaging Options .....	5.9-6
Pressure Side Identification .....	5.9-7
Ordering Information .....	5.9-8
Silicon Temperature Sensors .....	5.9-12

### RF Products ..... 5.10-1

RF Discrete Transistors .....	5.10-2
RF Power MOSFETs .....	5.10-4
RF Power Bipolar Transistors .....	5.10-6
HF Transistors .....	5.10-6
VHF Transistors .....	5.10-6
UHF Transistors .....	5.10-7
900 MHz Transistors .....	5.10-8
1.5 GHz Transistors .....	5.10-10
Microwave Transistors .....	5.10-10
Linear Transistors .....	5.10-12
RF Small Signal Bipolar Transistors .....	5.10-14
Selection by Package .....	5.10-15
Plastic SOE Case .....	5.10-15
Ceramic SOE Case .....	5.10-17
Selection by Application .....	5.10-18
RF Integrated Circuits .....	5.10-20
To 1.0 GHz .....	5.10-21
To 1.8 GHz .....	5.10-22
RF Amplifiers .....	5.10-23
High Power .....	5.10-25
Land Mobile/Portable .....	5.10-25
TV Transmitters .....	5.10-26
Low Power .....	5.10-27
CATV Distribution .....	5.10-27
CRT Drivers .....	5.10-30

### Surface Mount Information ..... 5.11-1

Information for Using Surface Mount Packages ....	5.11-2
Footprints for Soldering .....	5.11-5

### Tape and Reel Specifications and Packaging Specifications .... 5.12-1

Tape and Reel Specifications .....	5.12-2
Embossed Tape and Reel Ordering Information ..	5.12-3
Embossed Tape and Reel Data for Discretes ...	5.12-4
Lead Tape Packaging Standards for Axial-Lead Components .....	5.12-6
Packaging Specifications .....	5.12-7
TO-92 EIA Radial Tape in Fan Fold Box or on Reel .....	5.12-7

# Table of Contents

## Discrete Products (continued)

### Tape and Reel Specifications and Packaging Specifications (continued)

Fan Fold Box Styles .....	5.12-9
Adhesion Pull Tests .....	5.12-9
Reel Styles .....	5.12-10

### Leadform Options ..... 5.13-1

TO-92 (Case 29) & TO-225AA (Case 77) .....	5.13-2
TO-220 (Case 221A) .....	5.13-5
ICePAK Leadform Options .....	5.13-10

## CPTO Integrated Circuits, Discrete and International Products ..... 6.0-1

### General Information ..... 6.1-1

### CPTO Integrated Circuits ..... 6.2-1

Analog/Telecom & Special Function .....	6.2-2
Logic .....	6.2-5
ECL Products .....	6.2-5
100K ECLinPS Logic .....	6.2-5
ECLinPS Lite .....	6.2-6
MECL 10K Products .....	6.2-7
MECL 10KH Products .....	6.2-9
MECL III Products .....	6.2-10
MECL PLL .....	6.2-10
MPU Support CMOS .....	6.2-11
Programmable Logic .....	6.2-11
Advanced Schottky TTL (FAST) .....	6.2-12
Low Power Schottky (LS) .....	6.2-13
Metal Gate CMOS .....	6.2-17
TTL Products .....	6.2-19
Memories .....	6.2-20
Bipolar Memories .....	6.2-20
Specialty SRAMs .....	6.2-20
BiCMOS SRAMs .....	6.2-21
CMOS DRAMs .....	6.2-21
High Speed CMOS III Static Memories .....	6.2-22
Microprocessors .....	6.2-24
8-Bit Microprocessors .....	6.2-24
16- and 32-Bit Microprocessors .....	6.2-25
Single Chip Microcontrollers .....	6.2-26
Data Communications .....	6.2-27
Digital Signal Processing (DSP) .....	6.2-27
Reduced Instruction Set Computer (RISC) .....	6.2-28
Application Specific Integrated Circuit (ASIC) .....	6.2-28
MultiChip Modules (MCMs) .....	6.2-29

## CPTO Discrete Products ..... 6.3-1

Product Listing .....	6.3-2
MIL-Qualified Products .....	6.3-2
MIL-Processed Packaged Products .....	6.3-5
Product Selection Guide .....	6.3-6
MIL-Qualified Products .....	6.3-6
Power Transistors .....	6.3-6
Small-Signal Transistors .....	6.3-8
Bipolar .....	6.3-8
JFETs .....	6.3-11
Mil-Processed Discrete Semiconductors .....	6.3-12
Power Transistors .....	6.3-14
Small-Signal Transistors .....	6.3-15
Multiple Transistors .....	6.3-16
Surface Mounted Devices .....	6.3-17
RF Power Devices .....	6.3-17
CPTO Discrete Chips .....	6.3-18
Selector Guide .....	6.3-21

## CPTO International Products ..... 6.4-1

Reliability .....	6.4-2
Factory Qualifications .....	6.4-2
CECC 90 000 Screening Flow .....	6.4-2
CECC 50 000 Screening Flow .....	6.4-3
CECC Process Flow .....	6.4-3
Warranty/Rewarranty .....	6.4-3
T Series Flows .....	6.4-4
Warranty/Rewarranty .....	6.4-4
Microprocessors .....	6.4-5
Part Number Ordering Information .....	6.4-5
Marking Information .....	6.4-6
16- and 32-Bit Microprocessors .....	6.4-8
Microcontrollers .....	6.4-9
Reduced Instruction Set Computers (RISC) .....	6.4-10
Digital Signal Processors (DSP) .....	6.4-10
Logic, Analog and Special Functions .....	6.4-11
Part Number Ordering Information .....	6.4-11
Marking Information .....	6.4-13
CMOS Logic .....	6.4-15
High Speed CMOS (HCMOS) Logic .....	6.4-17
Advanced Schottky TTL (FAST) Logic .....	6.4-19
Low Power Schottky (LS) TTL .....	6.4-20
Advanced CMOS Technology .....	6.4-23
Analog Functions .....	6.4-24
Discretes .....	6.4-27
Part Number Ordering Information .....	6.4-27
Marking Information .....	6.4-27
Transistors .....	6.4-28
CECC Qualified .....	6.4-28
ESA/SCCG Qualified .....	6.4-28
CECC Processed .....	6.4-29
Diodes/Rectifiers .....	6.4-31
CECC Processed .....	6.4-31



# Table of Contents

## **Product Literature and Technical Training . . . . . 7.0-1**

Technical Data Services . . . . .	7.1-1
Motorola Semiconductor Master Selection Guide . . . . .	7.1-1
Semiconductor Data Update Magazine . . . . .	7.1-1
Mfax — Touch-Tone Fax . . . . .	7.1-1
Design-NET — Motorola Data On-Line . . . . .	7.1-1
Motorola Data and Application Literature . . . . .	7.1-2
Discrete Literature . . . . .	7.1-2
IC Literature . . . . .	7.1-2
Motorola Application Literature . . . . .	7.1-5
Technical Training 1994 . . . . .	7.1-6
Technical Training Centers . . . . .	7.1-8

## **Product Literature and Technical Training (continued)**

Audio Cassette Courses . . . . .	7.1-9
Video Training . . . . .	7.1-10

## **Device Index and Subject Index . . . . . 8.0-1**

Device Index . . . . .	8.1-1
General Index . . . . .	8.2-1
Subject Index . . . . .	8.2-13

## **Sales Offices and Distributors . . . . . 9.0-1**

# Semicustom Application Specific Integrated Circuits

## In Brief . . .

Motorola supports strategic programs and co-development partnerships to accelerate the availability of advanced processes (CMOS, BiCMOS, Bipolar), packaging and CAD technology. Extensive research, manufacturing and financial resources are focused to develop and maintain leading edge capabilities.

	Page
ASIC Preview . . . . .	1.1-1
Bipolar . . . . .	1.1-1
ECL & ETL Series Arrays . . . . .	1.1-1
CMOS . . . . .	1.1-1
1.0 Micron HDC Series	
Sub-Micron H4C & H4CPlus Series . . . . .	1.1-1
Design Automation Software (OACS™) . . . . .	1.1-1
Advanced Packaging . . . . .	1.1-1
Architecture for the 90's CDA™	
(Customer Defined Arrays) . . . . .	1.1-1
CDA — The Architecture of the '90s . . . . .	1.1-1
Bipolar ECL & ETL Series Arrays . . . . .	1.1-2
Third Generation . . . . .	1.1-2
ETL Series Arrays Extend Design Flexibility . . . . .	1.1-2
ETL Series Features Mixed ECL-TTL Interface . . . . .	1.1-2
CMOS . . . . .	1.1-3
1.0 Micron CMOS HDC™ Series . . . . .	1.1-3
Triple-Layer Metal . . . . .	1.1-3
Sub-Micron CMOS H4C™ Series . . . . .	1.1-4
CDA™ Architecture . . . . .	1.1-4
Sub-Micron CMOS H4CPlus™ Series	
Mixed 3.3 V/5.0 V Levels . . . . .	1.1-5
Design Automation Software . . . . .	1.1-6
The Open Architecture CAD System™ . . . . .	1.1-6
OACS™ 2.2 and 3.1M Features . . . . .	1.1-6
Advanced Packaging . . . . .	1.1-7
Quad Flat Pack Molded Carrier Ring	
(QFP-MCR) . . . . .	1.1-7
MicroCool™ Quad Flat Pack . . . . .	1.1-7
Over-Molded Pad Array Carrier (OMPAC™) . . . . .	1.1-7
Literature . . . . .	1.1-8
ASIC Regional Design Centers — United States . . . . .	1.1-8
ASIC Regional Design Centers — International . . . . .	1.1-8

**1**

# ASIC Preview

## Bipolar

### ECL & ETL Series Arrays

Motorola's MOSAIC III™ technology features modified transistor structures to reduce series base resistance and collector-base junction capacitance. The result is enhanced switching speed. Mixed ECL/TTL interface compatibility and high frequency (over 2.5 GHz) operation highlights the ETL Series.

## CMOS

### 1.0 Micron HDC Series

### Sub-Micron H4C & H4CPlus Series

High density CMOS arrays (HDC Series) are built on 1.0 micron drawn, triple-layer-metal CMOS process. By utilizing three layers of metal for signal routing, designers can achieve greater utilization on a channelless architecture.

The sub-micron (0.7 $\mu$ L<sub>eff</sub>) H4C Series enables densities over 300 K gates with 365 picosecond typical gate delay performance. It's available in Custom Defined Architecture (CDA).

Motorola's highest performance 0.6 micron CMOS arrays, the H4CPlus Series, are targeted for mixed 3.3 V and 5 V applications. The H4CPlus arrays range in density from 28,400 to 178,000 available gates with packages ranging from 128 QFP to 313 OMPAC.

## Design Automation Software (OACS™)

Motorola's Open Architecture CAD System (OACS) provides a complete ASIC development environment using industry-standard workstations and leading third-party design and verification tools. The OACS system integrates sophisticated ASIC design software tools to handle high performance designs and has the required flexibility to support future technology advances.

## Advanced Packaging

**OMPAC:** (Over-Molded Pad Array Carrier), a surface mount plastic package with solder bumps instead of traditional pins for interfacing to printed circuit boards.

**QFP-MCR:** Quad Flat Package in lead counts from 64 to 304 in optional Molded Carrier Ring which provides coplanarity and lead protection during manufacturing, testing and shipping.

**MicroCool QFP:** A new QFP-compatible plastic package with heat slug attached for improved heat dissipation capacity.

## Architecture for the 90's CDA™ (Customer Defined Arrays)

Performance, density and power dissipation are critical issues for next generation ASIC designs. The integration of large diffused blocks and embedded memory enhances intra-chip communication and saves board area. The Customer Defined Array (CDA) concept lets designers combine array-based, cell based, and full custom logic with diffused memory blocks on a die. The concept equally supports Bipolar and CMOS, each with the capability to incorporate BiCMOS modules.

1

## CDA — The Architecture of the '90s

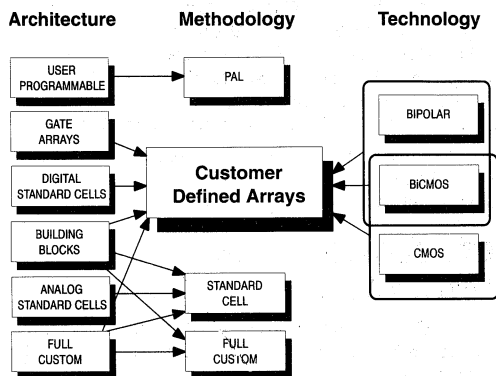

### Benefits

- Time-to-market through integration of functional building blocks and ASIC design methodology.
- Customers can create application specific arrays.
- Diffused RAM optimized for performance and density.
- Fixed die sizes for ease of manufacturing.



# Bipolar ECL & ETL Series Arrays

## Third Generation

### ETL Series Arrays Extend Design Flexibility

1

The ETL Series is flexible enough to simplify translation between high speed logic families.

Three base arrays:

MCA750ETL, MCA3200ETL, MCA6200ETL

- 848 to 6915 Equivalent Gates
- Channelled Architecture for up to 100% Utilization
- Input and Internal ECL Gate Delays – 0.20 ns (Typical)
- TTL Input/Translation Cell Delay – 0.55 ns (Typical)
- Up to 168 Universal I/O Signal Ports
- Bidirectional ECL and TTL I/O Macros
- ECL 100 K, Pseudo ECL and TTL Logic Interfaces
- Programmable Speed/Power Levels
- Three-Level Series Gated Macros
- MCA2 and MCA3 ECL Series Library Compatible

Motorola's MOSAIC III bipolar process offers unexcelled mixed TTL/ECL interface capability in a high performance, mature technology.

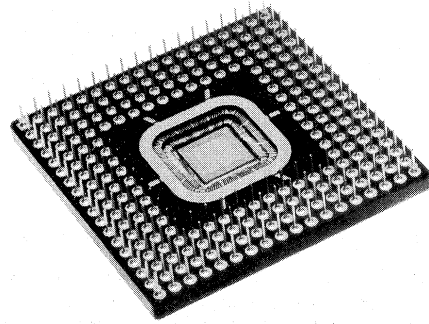

**Figure 1. MCA6200ETL in Multi-Layer Ceramic 224 Pin-Grid-Array Designed for High Frequency, Mixed-Mode Applications**

### ETL Series Features Mixed ECL-TTL Interface

The ETL Series offers mixed ECL, PECL (pseudo ECL) and TTL compatible interfaces. The Series combines 200 ps typical gate delays with 2500 MHz operating frequencies. Any signal pin can be programmed for input, output, or bidirectional signals in ECL, TTL or PECL logic. MOSAIC III process technology, combined with innovative design, extensive macrocell library and versatile I/O structure adds up to superior performance and flexibility.

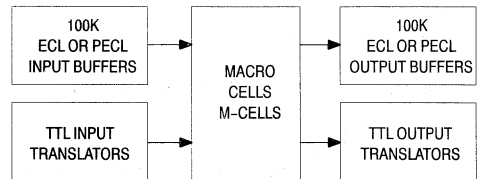

**Figure 2. ETL Series Block Diagram**

**Table 1. ECL & ETL Series Features**

Features	Array	MCA 2200ECL	MCA 10000ECL	MCA 750ETL	MCA 3200ETL	MCA 6200ETL
Technology		MOSAIC III				
Equivalent Gates		2412	12402	848	3570	6915
Internal (Major) Cells		68	414	24	110	225
I/O Signals		108	256	Universal I/O Ports		
Input/Interface Cells		96	224	42	120	168
Output (O) Cells		96	200			
Max Gate Delay (ns)		0.175	0.175	0.2	0.2	0.2
Max I/O Frequency (MHz)		1500	1200	2500	2500	2500
Typical Power Dissipation (W)		3-6	10-30	1-2	4-7	7-12

# CMOS

## 1.0 Micron CMOS HDC™ Series

### Triple-Layer Metal

Built on a 1.0 micron, triple-layer metal CMOS process, the HDC Series represents a significant advancement in microchip technology. By utilizing three layers of metal for signal routing and power distribution, designers can achieve maximum utilization on a channelless architecture having minimum chip dimensions. The result is high performance combined with I/O flexibility and density.

The HDC Series is available in a wide variety of plastic surface mount packages. The diversity of package style and pin count lets the designer best match system size, cost and performance requirements.

#### Features

- 3,000 to 49,000 available gates
- Up to 70% utilization
- Channelless Sea-Of-Gates architecture
- 1.0 micron drawn gate length ( $0.8 \mu\text{L}_{\text{eff}}$ )
- Triple layer metal routing and power distribution
- Eight transistor, fully utilizable, oxide isolated primary cell
- 475 picosecond typical gate delay (2-input NAND)
- Fixed RAM blocks (single, dual and quad)
- 5 V CMOS and TTL compatible I/O options
- Low power consumption of  $6 \mu\text{W}/\text{gate}/\text{MHz}$
- I/O cells can be paralleled on-chip for 48 mA drive
- Pin functions are 100% programmable as I/O or power on plastic packages
- 1000 V ESD protection, latchup immunity to 100 mA
- Comprehensive workstation based CAD support

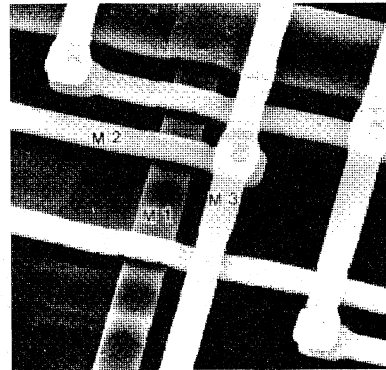

Figure 3. Triple-Layer Metal Signal Routing Enhances Utilization

1

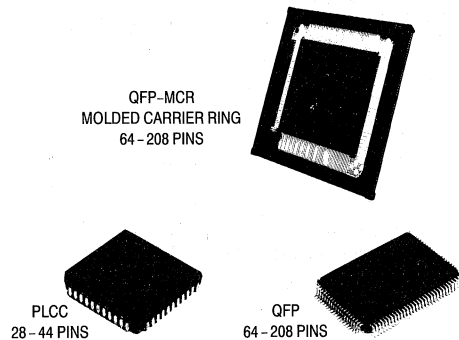

Figure 4. Typical HDC Series Packages

Table 2. HDC Series Features

Array	Available Gates	# of Die Pads (Wirebond)	Available I/O Cells	Die Size (mils square)	Package Pins
HDC003	3,036	76	88	136	28-68
HDC006	5,670	96	120	168	28-84
HDC008	8,208	108	144	182	28-100
HDC011	11,208	120	168	202	28-100
HDC016	16,416	136	204	232	68-128
HDC027	27,270	168	264	282	84-160
HDC031	31,290	180	280	295	68-160
HDC049	49,368	216	352	354	160-208

# Sub-Micron CMOS H4C™ Series

## CDA Architecture

1

The H4C Series of CMOS Customer Defined Arrays™ (CDA) provides a new generation of ASICs to capture the functionality of the sub-micron process. The new fabrication process of the H4C Series supports speed requirements of 60 MHz processors with a power dissipation of only 3 μW/MHz/gate.

The CDA architecture offers the versatility and efficiency of system design on a single chip by providing large, fully-diffused architectural blocks such as user configurable SRAMs. Additionally, to ensure high quality ASIC system designs, several design-for-test implementations and clock skew management schemes are available.

### Features

- 18,080 to 317,968 available gates
- Compatible channelless, Sea-Of-Gates and CDA architectures
- 0.7 micron effective gate length
- Triple-layer-metal signal routing and power distribution
- Up to 70% gate utilization (smaller arrays)
- 365 picosecond typical gate delay (2-input NAND)
- User configurable, fully diffused SRAM blocks up to 256K bits
- Low power consumption – 3 μw/MHz/gate
- 3.3 V and 5.0 V CMOS and TTL compatible I/O cells
- BIST, JTAG (IEEE 1149.1) and LSSD/ESSD scan supported
- Digital PLL to manage clock skew
- Boundary scan embedded in periphery
- Extended workstation-based CAD support for embedded functions
- Clock tree synthesis and clock skew management

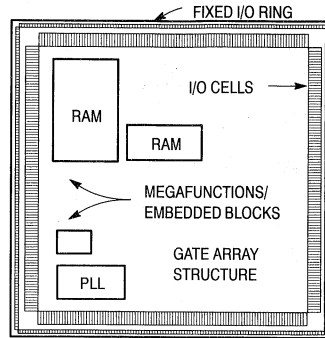

Figure 5. The CDA Concept: Megafunctions and Embedded Blocks Within a Gate Array

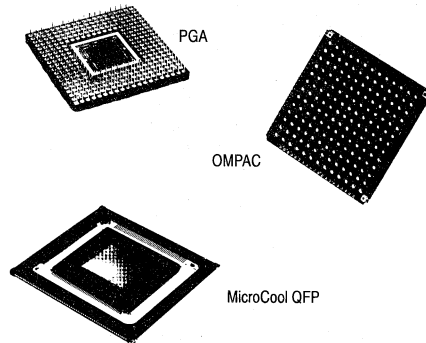

Figure 6. Typical H4C Series Packages

Table 3. H4C Series Features

Array	Available Gates	# of Die Pads	I/O Cells	Package Pins
H4C018	18,080	136	160	80-120
H4C027	27,048	160	196	80-128
H4C035	35,392	176	224	80-160
H4C057	57,368	216	284	80-225
H4C086	85,956	256	344	120-225
H4C123	123,136	304	416	160-313
H4C161	161,364	344	476	160-313
H4C195	195,452	376	524	160-375
H4C267	266,832	432	612	447
H4C318	317,968	468	668	447

## Product Preview

# Sub-Micron CMOS

## H4CPlus™ Series

### Mixed 3.3 V/5.0 V Levels

The new sub-micron CMOS H4CPlus Series is targeted for mixed 3.3 V and 5 V applications, as well as low-power 3.3 V systems. The H4CPlus arrays range in density from 28,400 to 178,000 available gates with packages initially ranging from 128 QFP to 313 OMPAC.

A key feature of this family is a powerful I/O buffer aimed at meeting the requirement for GTL I/O levels and capable of driving backplanes of 50  $\Omega$  transmission lines in today's high-performance RISC/CISC microprocessor-based systems.

For the highest possible chip-to-chip operating frequencies, the H4CPlus family introduces Current Mode Transceiver Logic™ (CMTL™) buffers. This new self-terminating I/O method permits CMOS chip-to-chip interface speeds (using typical differential or single-ended inputs) to 250 MHz, at low power dissipation. It also provides a differential interface directly to industry standard ECLinPS™ logic when used with a +5 V rail.

#### Features:

- 0.6 micron effective gate length
- Typical gate delay of 280 ps for a NAN2, FO = 2 at 5 V
- Power dissipation of 1  $\mu$ W/gate/MHz at 3.3 V
- Standard 5 V high performance or 2.7 V to 3.6 V low power configurations, with mixed 3.3 V and 5 V combinations
- Single I/O site, 2 mA to 24 mA drive, TTL and CMOS output macros
- PECL input buffer macros supporting inputs to 250 MHz Typical
- Current Mode Transceiver Logic I/O buffer for self-terminated, high-speed differential or single-ended interfacing to 250 MHz
- Separate 5 V and 3.3 V power bussing
- Embedded analog PLL\* macros for up to 125 MHz clocks
- Industry standard JTAG boundary scan built into I/O macros
- DFT methodology support (JTAG, BIST, LSSD, ESSD)

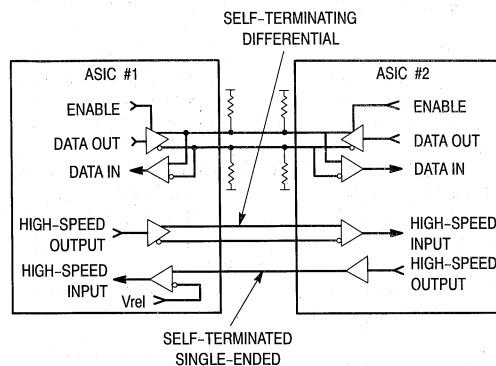

Figure 7. Interfacing H4CPlus Series with Current Mode Transceiver Logic

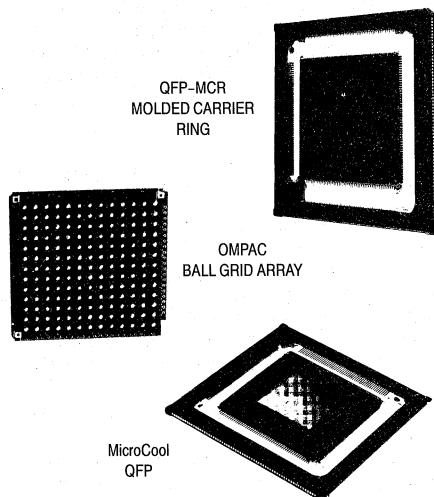

Figure 8. Typical H4CPlus Series Packages

Table 4. H4CPlus Series Features

Array Name	Available Gates	Die Size (mils/side)	Die Pads Wirebond	I/O Cells	Package Pins
H4CP028	28,400	239	176	160	128-169
H4CP048	48,100	287	216	208	128-225
H4CP075	74,520	337	256	256	128-225
H4CP109	109,368	391	304	312	160-313
H4CP146	145,544	438	344	360	160-313
H4CP178	178,000	476	376	400	160-313

This document contains information on a product under development. Motorola reserves the right to change or discontinue this product without notice.



# Design Automation Software

Motorola has worked closely with several leading CAD/CAE vendors to integrate the best design tools in the industry into one system. In many cases, Motorola has been instrumental in the definition and refining of key third-party design tools.

1

To satisfy specific CAD requirements, Motorola has developed several design tools to perform netlisting and translation, rule checking, delay and timing calculation, fault grading and automatic test pattern generation, floorplanning, test vector analysis and processing.

The OACS 2.2 and 3.1M features chart briefly describes Motorola's OACS™ ASIC design system options.

## The Open Architecture CAD System™

The Open Architecture CAD System (OACS) offers a highly versatile and powerful design environment for the design of Motorola's H4CPlus, HC4 Series, and HDC Series CMOS arrays. The OACS integrates several of the industry's most powerful design tools with Motorola's high-performance tools

### OACS™ 2.2 and 3.1M Features:

- EDIF 2.0.0 backplane approach to providing an open design environment
- Supports the following third-party design tools:
  - Synopsys' Design Compiler™, HDL Compiler™, Test Compiler™ (optional) and Design Wave™
  - Cadence's Concept™ schematic capture (2.2)
  - Cadence's Verilog XL™ simulator and Veritime™ static timing analysis (2.2)
  - Quad Design's MOTIVE® static timing analysis (optional) (2.2)
  - Mentor Graphics' Falcon Framework™ (3.1M)
  - Mentor Graphics' QuickSim II™ simulator and QuickPath™ static timing analysis (3.1M)
  - Mentor Graphics' AutoLogic™ design synthesis tool
  - Cadence's Gate Ensemble™ and Dracula™ physical layout and verification tools (factory only)
- Motorola design tools:
  - Memorist™ diffused SRAM compiler (optional)
  - Mustang™ automatic test pattern generation (optional)

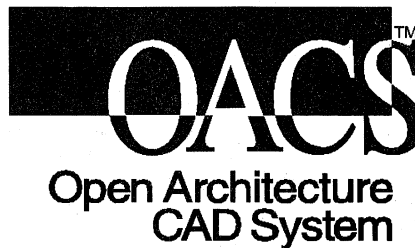

into a standard EDIF based CAD environment. The release of this Design Reference Guide corresponds to the release of two major versions of OACS: OACS 2.2 and OACS 3.1M.

OACS 2.2 is Motorola's point tool CAE solution based on Cadence's Concept™ schematic editor, Synopsys' synthesis tools, and Cadence's Verilog™ logic simulator.

OACS 3.1M is Motorola's framework based CAE solution using Mentor's Falcon Framework™. This solution provides support of Mentor's design entry tools and QuickSim II logic simulation.

- TestPAS™ test vector validation and extraction
- ERC and MARV comprehensive electrical and manufacturing rules checking
- PrediX™ floorplanning (optional)
- Testability support: ESSD/LSSD scan, JTAG boundary scan, BIST, and scan synthesis
- Sophisticated delay and timing limits calculations for accurate simulation and timing analysis
- Estimated and actual (back-annotated) wire capacitances
- Includes intrinsic, rise/fall time, output pin loading and distributed RC delays
- Continuous process, temperature, and voltage variation
- Clock skew management: clock-tree synthesis, PLL, timing driven layout
- Supports multiple technologies: HDCMOS, H4C, H4C-CDA-1C, H4CPlus
- Supported on HP9000/7XX and SUN-4 SPARC® workstations

## Advanced Packaging

Low cost, high performance systems require excellence in ASIC packaging technology. MicroCool, QFP-MCR (Quad Flat Pack in an optional Molded Carrier Ring), and Over-Molded Pad Array Carrier (OMPAC) packages illustrate cost-effective manufacturing solutions for high lead count, high frequency applications.

### Quad Flat Pack Molded Carrier Ring (MCR-QFP)

Motorola currently offers the popular EIAJ standard Plastic Quad Flat Package (QFP) in lead counts from 64 to 240 pins. The Molded Carrier Ring (MCR) is a coplanarity and lead protection device for QFP packages. The ring provides lead protection during manufacturing/testing and shipping.

Standard ring sizes simplify manufacturing across the range of packages and improve component testability.

### MicroCool™ Quad Flat Pack

The MicroCool QFP is a new QFP compatible plastic package with improved heat dissipation capacity. It has a heat slug attached to a printed circuit board which supports a copper lead frame. The package incorporates a molded carrier ring to maintain pin coplanarity. Lead counts range from 64 to 304 points. MicroCool packaging is cost-effective and capable of meeting high power dissipation (up to 5 W, depending on temperature and ambient conditions).

#### Features:

- Thermally improved footprint compatible version of MCR-QFP package
- Constructed using PCB with attached leadframe and heat slug. The die is attached to the slug which is exposed on the package top surface
- Coplanarity less than 4 mils using MCR techniques—(PCB material aids good coplanarity by cutting bowing of plastic)

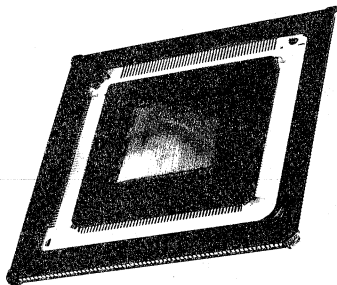

Figure 9. MicroCool Quad Flat-Pack in Molded Carrier Ring Lowers Board Cost and Improves Thermal Performance

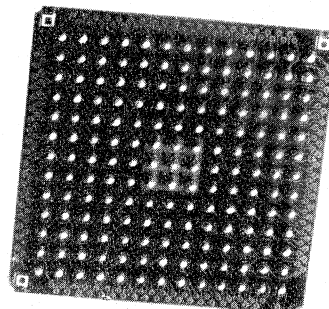

Figure 10. 169-lead OverMolded Pad Array Carrier (OMPAC) Saves Board Space and Improves Manufacturing Yields

1

### Over-Molded Pad Array Carrier (OMPAC™)

OMPAC consists of a thin double metal printed circuit board, overmolded with plastic. The integrated circuit is attached to a gold-plated die flag on the substrate with a silver-filled epoxy. Electrical connections to the integrated circuits are made using conventional gold ball bonding techniques.

#### Primary Advantages Over QFP

- Eliminates concerns with lead coplanarity
- Improved electrical performance
- Comparable or better thermal performance
- Requires less costly PCB pitch
- Smaller size
- No risk of lead damage
- Improved manufacturing yields
- Competitive pricing

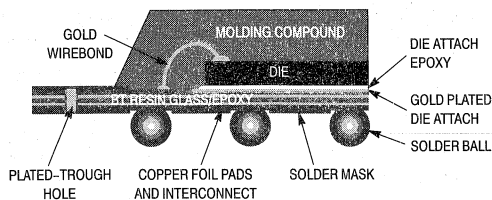

Figure 11. Simplified Cross-Sectional View of OMPAC

# Literature

To order any literature item, call or write:

Motorola Semiconductor Products  
Literature Distribution Center  
P.O. Box 20912, Phoenix, Arizona 85036  
(602) 994-6561

1

## Order Number Description

### Design Manuals

H4CDM/D	H4C Series CMOS Arrays
H4CPDM/D	H4CPlus Series CMOS Arrays
HDCDM/D	HDC Series CMOS Arrays
MCA3ECL/D	MCA3 ECL Series Arrays
MCA3ETLDM/D	MCA3 ETL Series Arrays
MC92005UM/D	SBus Interface Controller

### Data Sheets

ETL/D	MCA3 ETL Series Macrocell Arrays
H4C/D	Sub-micron H4C Series CMOS Arrays
H4CP/D	H4CPlus Series CMOS Arrays
HDC/D	HDC Series CMOS Arrays
MCA2200ECL/D	MCA2200ECL Macrocell Array
MCA10000ECL/D	MCA10000ECL Macrocell Array
MC92005/D	Slave Interface Controller

### Brochures/Selector Guides/Misc.

SG367/D	ASIC Product Overview
BR916/D	Packaging Manual for ASIC Arrays
BR931/D	Symbols to Silicon (C_LAN)
BR1400/D	Open Architecture CAD System — OACS 2.x
BR1417/D	Open Architecture CAD System — OACS 3.xM

## Order Number Description

### Application Notes/Article Reprints

AN1093/D	Delay and Timing Methods for CMOS ASICs
AN1095/D	Clock Distribution
AN1096/D	Guidelines for Using the Mustang™ ATPG System
AN1099/D	Test Methodology for HDC Series Arrays
AN1500	JTAG Boundary Scan for H4C/H4CPlus Arrays
AN1502/D	Embedded RAM/BIST
AN1508/D	High Frequency Design Techs & Guidelines for Bipolar Gate Arrays
AN1509/D	ASIC Clock Distribution Using PLL
AN1512/D	TestPAS Primer
AN1514/D	H4CPlus Series 3.3 V/5 V Design Considerations
AR518/D	Gate Arrays Simplify Translation between High Speed Logic Families
AR522/D	Ranking of Gate Array Vendors
AR524/D	ASIC Package Selection

## ASIC Regional Design Centers — United States

California, San Jose  
(408) 749-0510

Illinois, Chicago  
(708) 490-9500

Massachusetts, Marlborough  
(508) 481-8100

## ASIC Regional Design Centers — International

**European Headquarters,**  
Germany, Munich  
(089) 92103-0

England, Aylesbury, Bucks  
(0296) 395252

France, Velizy  
(01) 34635900

Holland, Eindhoven  
(04998) 61211

Hong Kong, Silicon Harbour, Tai Po  
(852) 666-8333

Japan, Tokyo  
(03) 440-3311

Sweden, Stockholm  
(08) 734-8800

Italy, Milan  
(02) 82201

# Microcomputer Components

---

## In Brief . . .

Motorola continues to be a leading supplier of components for microcomputer systems. The product portfolio includes digital signal processors; CISC and RISC and PowerPC advanced microprocessors and complementary full-function peripherals; a comprehensive selection of high-performance microcontrollers; VLSI functions for Local Operating Network applications; and a broad range of fast static RAM and dynamic RAM chips and modules.

Our commitment is to provide state-of-the-art devices as well as continuing support of established products, with six-sigma quality and total customer satisfaction.

	<b>Page</b>
Digital Signal Processors . . . . .	2.1-1
The M68000 Family . . . . .	2.2-1
The M88000 RISC Family . . . . .	2.3-1
The PowerPC RISC Family Microprocessors . . . . .	2.4-1
Single-Chip Microcontrollers (MCU) . . . . .	2.5-1
LonWorks Products . . . . .	2.6-1
MOS Memories . . . . .	2.7-1

**2**

# Digital Signal Processors

---

## In Brief . . .

Drawing on both design excellence and expertise in manufacturing, Motorola has created a range of architecturally compatible Digital Signal Processing chips. The philosophy behind the DSP families has been to create compatibility between products as well as conformance to international standards.

Currently, Motorola addresses three main areas of DSP hardware: general purpose, algorithm specific processors and peripherals. Our general purpose processors include 16- and 24-bit fixed point and 32-bit floating point families.

In addition, we offer a comprehensive array of development tools to give the designer access to the full power and versatility of the DSPs with minimum fuss. All the tools were designed for ease of use and functionality. They provide a low-cost means of evaluation and greatly simplify the design and development phase of a DSP project.

	<b>Page</b>
DSP56100 — 16-Bit Digital Signal Processors ..	2.1-2
DSP56000 — 24-Bit Digital Signal Processors ..	2.1-3
DSP96000 — 32-Bit Digital Signal Processors ..	2.1-4
DSP Peripherals .....	2.1-5
DSP56200 — The Cascadable Adaptive Finite Impulse Response Digital Filter .....	2.1-5
DSP56ADC16 — The Analog-To-Digital Converter ..	2.1-6
DSP56401 — The Digital Audio Transceiver .....	2.1-6
DSP Development Tools .....	2.1-7
Application Development Systems .....	2.1-7
DSP Development Software .....	2.1-8
Design-In Software Packages .....	2.1-8
C-Compiler Packages .....	2.1-9
C-Compiler Upgrades .....	2.1-9

# 16-/24-/32-Bit Families — Your Complete DSP Solution

## DSP56100 — 16-Bit Digital Signal Processors

The DSP56100 family of HCMOS, low-power, 16-bit fixed-point general-purpose digital signal processors (DSP) is ideal for high end speech coding, telecommunications and control applications. The first DSP56100 family member, the DSP56156, combines the high-speed core with 8K bytes RAM, two serial ports, one parallel port, codec, phase-locked loop (PLL) and On-Chip Emulation (OnCE™). The DSP56166, the second member of the DSP56100 family, has identical package and pinout to the DSP56156 with different memory configuration and peripherals.

2

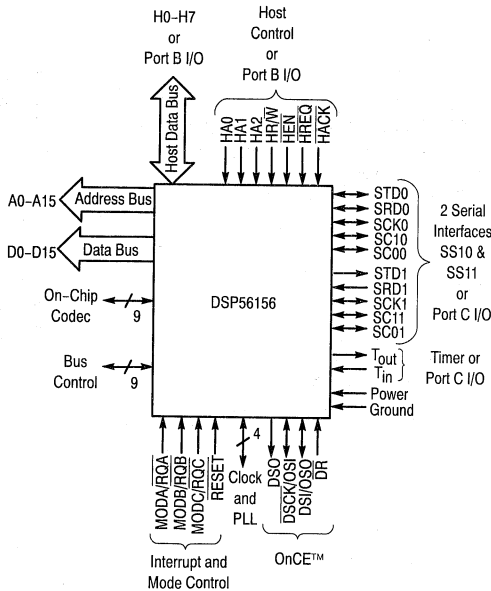

### PART NUMBERS

Part	Description
XC56156FE40	40 MHz in CQFP
XC56156FE60	60 MHz in CQFP
XC56166FE60	60 MHz in CQFP

### DSP56156 BENCHMARKS

Benchmark	Instruction Cycles
Real FIR Filter with Data Shift	1 per Tap
LMS Adaptive Real FIR Filter	2 per Tap
Double Integration Sinewave Generation	2 per Sample
Complex FIR Filter with Data Shift	4 per Tap
General Lattice Filter	4 per Tap
Real Cascaded IIR Biquad Filter Sections (4 coeff.)	5 per Section
PID Loop	5
Double Precision Multiply	6
[1x3][3x3] Matrix Multiplication	21

### DSP56100 Features

- Up to 30 Million Instructions per Second (MIPS) at 60 MHz – 33.3 ns Instruction cycle
- Single-cycle 16 x 16-bit parallel Multiply-Accumulate
- 2 x 40-bit accumulators with extension byte
- Fractional and integer arithmetic with support for multiprecision arithmetic
- Highly parallel instruction set with unique DSP addressing modes
- Nested hardware DO loops including infinite loops and DO zero loop
- Two instruction LMS adaptive filter loop
- Fast auto-return interrupts
- Three external interrupt request pins
- Three 16-bit internal data and three 16-bit internal address buses
- Individual programmable wait states on the external bus for program, data, and peripheral memory spaces
- Off-chip memory-mapped peripheral space with programmable access time and separate peripheral enable pin
- On-chip memory-mapped peripheral registers
- Low Power Wait and Stop modes
- On-Chip Emulation(OnCE) for unobtrusive, processor speed independent debugging
- Operating frequency down to DC
- 5V single power supply
- Low Power (HCMOS)

# DSP56000 — 24-Bit Digital Signal Processors

The DSP56000 family of 24-bit fixed-point general purpose DSP is Motorola's original DSP family. This family with its triple Harvard architecture of seven internal buses and three parallel execution units — Data ALU, Address Generation Unit (AGU) and Program Controller — has set the standard for high end DSP devices. Motorola has retained architecture compatibility with the 24-bit DSP family into the newer 16-bit DSP56100 and 32-bit DSP96002 products helping to preserve our customer software investment.

The DSP56000 family of HCMOS, low-power, 24-bit DSP currently consists of six products: DSP56000, DSP56001, DSP56002, DSP56L002 and DSP56004. These products are utilized extensively in telecom— communications, control and audio. The DSP56000 family's unique 24-bit architecture has made these products the industry standard for CD-quality digital audio processing.

All DSP56000 Family members are source code compatible products. The DSP56000 and DSP56001 are the original two members and are identical except that the DSP56001 is program RAM based (512 x 24) while the DSP56000 contains a customer specific program ROM (3.75K x 24). The DSP56002 is a next generation DSP56001 with similar on-chip peripherals and memories. The DSP56002 provides faster clock speed (66 MHz) and adds phase-locked loop (PLL) and On-Chip Emulation.

The DSP56L002 is a low-voltage implementation of the DSP56002. Its 3.3 volt operation effectively extends the battery life of portable applications up to three times longer than 5 volt systems.

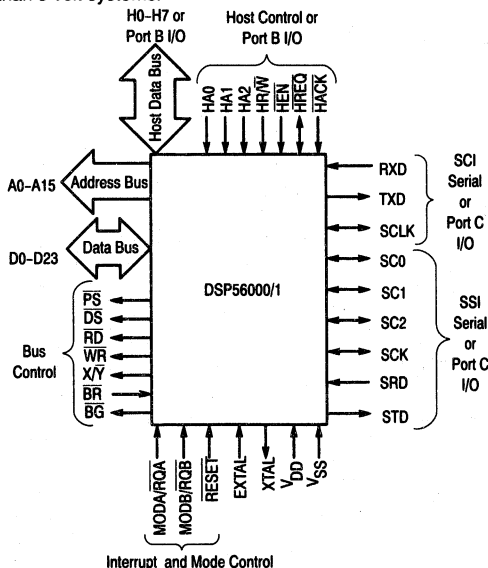

## DSP56001 BENCHMARKS

Benchmark	Instruction Cycles
Real FIR Filter with Data Shift	1 per Tap
Two Dimensional Convolution (3x3 coeff. mask)	1 per Output
LMS Adaptive Real FIR Filter	3 per Tap
Real Cascaded IIR Biquad Filter Sections (4 coeff.)	4 per Section
Complex FIR Filter with Data Shift	4 per Tap
[1x3][3x3] Matrix Multiplication	17
Division	28
Leroux-Gueguen LPC Analysis:	
8th Order	473
10th Order	622
16th Order	1203

2

## DSP56001/2 Features

- DSP56000 family architecture
  - 16.5 MIPS, 60 ns instruction cycle at 33 MHz (DSP56001)
  - 33 MIPS, 30 ns instruction cycle at 66 MHz (DSP56002)
  - Single cycle 24 x 24 → 56-bit multiply/accumulate
  - Two 56-bit accumulators
  - Zero-overhead nested DO loops
  - Two instruction cycle fast interrupts
  - 15-level stack
  - Low-power Wait and Stop Modes
  - On-Chip Emulation for unobtrusive, full speed debugging (DSP56002)
  - Phase-locked loop frequency synthesizer (DSP56002)
- DSP56001 on-chip memories
  - 512 x 24 program RAM
  - 2 x 256 x 24 data RAM
  - 2 x 256 x 24 data ROM (sine and cosine tables)
- DSP56001/2 on-chip peripherals
  - Full-speed memory expansion port with 16-bit address and 24-bit data buses
  - Byte-wide Host Interface with DMA support
  - Synchronous Serial Interface port
  - Serial Communication Interface (asynchronous) port
  - 24 general-purpose I/O pins
- 132-pin plastic quad flatpack (PQFP) or 88-pin PGA (DSP56001)/132-pin PGA (DSP56001)



## DSP56000 — 24-Bit Digital Signal Processors (continued)

The DSP56004 contains audio peripherals specially designed for consumer and automotive audio applications. The DSP56004 uses the same processing and memory modules as the DSP56002. The Serial Audio Interface (SAI) provides two stereo inputs and three stereo outputs with I<sup>2</sup>S, Sony or Matsushita formats. The External Memory Interface (EMI) supports a byte-wide data port to DRAM or SRAM. The Serial Host Interface (SHI) provides a low-cost microcontroller interface using SPI or I<sup>2</sup>C.

**2**

### DSP56004 Features

- DSP56000 family architecture
- DSP56004 on-chip memories
- DSP56004 on-chip peripherals
  - Serial Audio Interface (SAI)
  - External Memory Interface (EMI)
  - Serial Host Interface (SHI)
  - Four general-purpose I/O pins
- 80-pin plastic quad flatpack (PQFP)

### PART NUMBERS

Part	Description
DSP56000RC20	20 MHz ROM-based in PGA
DSP56000FE20	20 MHz ROM-based in CQFP
DSP56000FC20	20 MHz ROM-based in PQFP
DSP56001RC20	20 MHz RAM-based in PGA
DSP56001FE20	20 MHz RAM-based in CQFP
DSP56001FC20	20 MHz RAM-based in PQFP
DSP56001RC27	27 MHz RAM-based in PGA
DSP56001FE27	27 MHz RAM-based in CQFP
DSP56001FC27	27 MHz RAM-based in PQFP
DSP56001RC33	33 MHz RAM-based in PGA
DSP56001FE33	33 MHz RAM-based in CQFP
DSP56001FC33	33 MHz RAM-based in PQFP
DSP56002RC40	40 MHz RAM-based in PGA
DSP56002FC40	40 MHz RAM-based in PQFP
DSP56L002FC40	40 MHz RAM-based in PQFP
XC56002FC66	66 MHz RAM-based in PQFP
XC56004FJ40	40 MHz 80-pin PQFP

## DSP96000 — 32-Bit Digital Signal Processors

The DSP96000 has full architecture compatibility with the 16-bit DSP56100 and 24-bit DSP56000 Families. The DSP96002 is the first in a family of 32-bit IEEE floating-point DSP devices. The DSP96002 has two identical memory expansion ports simplifying network configurations for multiprocessor and DSP96002 communications. These ports interface to SRAM, DRAM (operating in their fast access modes), video RAM or directly to other processors with host interface logic.

Although designed primarily for image processing, other proven applications include communications, spectrum analysis, instrumentation, speech processing and pattern recognition.

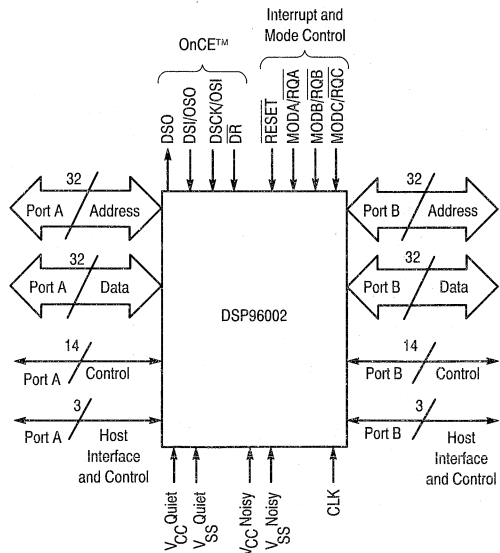

## DSP96000 — 32-bit IEEE Floating Point Dual-Port Processors (continued)

### PART NUMBERS

Part	Description
XC96002RC33	33 MHz in PGA
XC96002RC40	40 MHz in PGA

### DSP96002 BENCHMARKS

Benchmark	Instruction Cycles
Real	
FIR Filter with Data Shift	1 per Tap
$V = V * S + V$	2
Lattice Filter with Data Shift	3 per Tap
Cascaded IIR Biquad Filter Sections (4 coeff.)	4 per Section
1024-point FFT and bit reversal	12880
Complex	
$V = V * V + V$	4
FIR Filter with Data Shift	4 per Tap
1024-point FFT and bit reversal	20931
Graphics/Image Processing	
Divide (32-bit accuracy)	7
Square Root (32-bit accuracy)	12
Bezier Cubic Evaluation for Font Compilation	13
$[4 \times 4][4 \times 4] = [4 \times 4]$	67

### DSP96002 Features

- DSP96000 family architecture
  - Full IEEE Standard 754 compatible for 32-bit (SP) and 44-bit (SEP) arithmetic
  - 20 MIPS, 50 ns instruction cycle at 40 MHz
  - 60 million floating-point operations per second (MFLOPS) at 40 MHz
  - Single cycle  $32 \times 32 \rightarrow 96$ -bit multiply/accumulate
  - Ten 96-bit general-purpose data registers
  - Zero-overhead nested DO loops
  - Two instruction-cycle fast interrupts
  - Low-power Wait and Stop Modes
  - On-Chip Emulation for unobtrusive, full-speed debugging
  - 4K byte instruction cache
  - Integer mode available
  - Single precision mode available
  - Timer/Event Counter
- DSP96002 peripherals
  - Two 32-bit address and data host ports
  - Dual channel DMA controller
- DSP96002 memories
  - 1024 x 32 program RAM
  - 2 x 512 x 32 data RAM
  - 2 x 512 x 32 data ROM (sine and cosine tables)

2

## DSP Peripherals

### DSP56200 — The Cascadable Adaptive Finite Impulse Response Digital Filter

The DSP56200 is an algorithm-specific DSP peripheral designed to perform computationally-intensive tasks. Two principal algorithms are implemented on the DSP56200 making the primary functions finite impulse response (FIR) and adaptive FIR filtering. Its performance, features and simple interface with host microprocessors make the DSP56200 a natural solution for echo cancelling, noise cancelling, convolution, correlation and orthogonal transform applications.

### PART NUMBERS

Part	Description
XC56200LC10	10.5 MHz in Ceramic DIP

### Key Features

- Low Power HCMOS
- 100 ns per tap throughput
- 256x16-bit data RAM
- 256x24-bit coefficient RAM
- 16x24-bit multiplier, 40-bit accumulation
- Three modes of operation
  - Single FIR filter
  - Dual FIR filter
  - Single adaptive FIR filter with dc tap and leakage control
- Programmable tap lengths
  - 256 taps in single channel mode
  - 128 taps per channel in dual mode
- Cascadable in single channel mode
- Programmable leakage and gain
- 8-bit I/O port with 7 control lines
- Scratch pad memory
- Power down mode

## DSP Peripherals (continued)

### DSP56ADC16 — The Analog-To-Digital Converter

The DSP56ADC16 is a single-chip, linear analog-to-digital (A/D) converter. It is an ideal choice for high-performance digital audio systems, voice-bandwidth communication and control applications. It does not require antialiasing filters and sample-and-hold circuitry because they are an inherent part of the sigma-delta technology. The DSP56ADC16 can be easily interfaced to the DSP56001 and other host processors using its flexible serial interface.

2

#### Key Features

- 16-bit output resolution at 100 kHz from FIR filter
- 12-bit output resolution at 400 kHz from Comb filter
- 96-dB dynamic range
- 90-dB signal-to-THD ratio
- 90-dB signal-to-noise ratio
- In-band ripple: <0.001 dB

- Maximum output sample rates:
  - FIR filter — 100 kHz
  - Comb filter — 400 kHz
- Maximum input sample rate is 6.4 MHz
- Maximum internal clock rate is 12.8 MHz
- DC stability is 10-bits
- Supply voltage is single +5V ( $\pm 10\%$ )
- Supply current is <100 mA
- Linear-phase analog front end and internal digital filters
- Simple serial interface to host microprocessors
- Fully differential inputs

#### PART NUMBERS

Part	Description
DSP56ADC16S	16-bit in Ceramic DIP

### DSP56401 — The Digital Audio Transceiver

The DSP56401 is a low-cost, digital audio transceiver system which is compatible with the AES/EBU and EIAJ CP340 digital audio transmission standards. These standards are supported by CD players, RDAT recorders, professional recording and broadcasting equipment, audio workstations, and other applications including using RDAT recorders as mass storage for general data. The serial interfaces provide a no-glue interface to Motorola DSP SSI and SCI ports, 6805 and 68HC11 SPI ports, and Motorola Sigma-Delta A/D and D/A converters. Eight serial modes provide flexible interfacing for the audio sample data and the non-audio information in various systems.

#### Key Features

- Single-chip digital audio system — transmitter, receiver and clock generation
- Compatible with the AES/EBU and EIAJ CP340 digital audio transmission standards
- Allows simple audio-only data interfaces or full-featured AES/EBU systems
- Independently clocked on-chip transmitter, receiver and serial interfaces
- Four on-chip oscillators with on-chip programmable dividers
- On-chip phase locked loop frequency and phase detectors
- Three software selected digital audio inputs
- Two programmable clock outputs
- Four programmable I/O pins
- No-glue interface to Motorola DSP SSI, I<sup>2</sup>S and Japanese digital audio interfaces
- No-glue interface to Motorola DSP SCI and MCU SPI ports for non-audio data

- Serial daisy-chain supports digital audio buses having multiple DSP56401 and data converter time slots
- Simultaneous stereo sampling with two Motorola DSP56ADC16 A/D converters
- Low jitter clock recovery compatible with Sigma-Delta converter requirements
- Multi-Port Serial Interface™ provides eight serial data formats
- Programmable number of 16, 24 or 32 bit serial time slots
- All non-audio information is available at fast or slow transfer rates
- Non-audio data interface supports SSI, SCI, SPI and EPROM ports
- User features and DSP software loading controlled by software drivers
- 24-bit program word and 16-bit status word control and monitor on-chip operation
- Hardware parity generation and error detection
- Hardware CRC generation and error detection
- Multiple chip transmit modulator synchronization
- TTL compatible inputs, CMOS compatible outputs

#### PART NUMBERS

Part	Description
DSP56401FN	68-pin PLCC (Plastic Leaded Chip Carrier) Surface Mount Package

# DSP Development Tools

## Application Development Systems

Every member of the Motorola Family of 16-, 24- and 32-bit DSPs is supported by a multi-component Application Development System (ADS) which acts as a tool for designing, debugging and evaluating real-time DSP target system equipment. The ADS simplifies evaluation of the user's prototype hardware/software product by making all of the essential timing and I/O circuitry easily accessible. Using an IBM PC™, Macintosh™ II or a Sun-4™ as a medium between the user and the DSP hardware significantly reduces the overall complexity and cost of development while increasing the capabilities of the system. With the ADS, DSP programs can be executed in real-time, single instruction traced or multiple instruction stepped with registers and/or memory block contents displayed. The ADS is fully compatible with the CLAS design-in software package for each product and may act as an accelerator for testing DSP algorithms.

Emulation capability is available for the DSP56000ADS with the addition of an emulator cable which plugs into the euro-card connector on the ADS board. The DSP56156ADS and DSP96002ADS offer an On-Chip Emulation (OnCE™) circuit for unobtrusive, processor speed independent debugging. The ADS takes full advantage of this circuit to allow the user non-intrusive control of the target.

The DSP56KT2, a direct replacement of the DSP56000ADS and emulator cable, is a four-component system which acts as a real-time signal processing emulator pod for DSP56000/1 target applications. The DSP56KT2 takes advantage of the OnCE port of the DSP56002 to provide non-intrusive, real-time support by allowing users to debug target systems at zero wait state, 33 MHz operation.

### General ADS Features

#### Software —

- Single/multiple stepping through DSP object programs
- Conditional/unconditional software and hardware breakpoints
- Program patching using a single-line assembler/disassembler
- Session and/or command logging for later reference
- Loading and saving of files to/from ADM memory
- Macro command definition and execution
- Display enable/disable of registers and memory
- Debug commands which support multiple DSP development
- Hexadecimal/decimal/binary calculator
- Multiple input/output file access from DSP object programs
- On-line help screens for each command and register

#### Hardware —

- Full speed operation
- Multiple ADM support with programmable ADM addressing
- Stand-alone operation of ADM after initial development

### PART NUMBERS

Development Systems	Host Machine
DSP56100ADSA	IBM PC
DSP56100ADSB	Macintosh II
DSP56100ADSF	Sun-4
DSP56000ADSA	IBM PC
DSP56000ADSB	Macintosh II
DSP56000ADSF	Sun-4
DSP96000ADSA	IBM PC
DSP96000ADSB	Macintosh II
DSP96000ADSF	Sun-4
DSP56002ADSA	IBM PC
DSP56002ADSB	Macintosh II
DSP56002ADSF	Sun-4
DSP56004ADSA	IBM PC
DSP56004ADSB	Macintosh II
DSP56004ADSF	Sun-4
DSP56KT2A	IBM PC
DSP56KT2B	Macintosh II
DSP56KT2F	Sun-4
DSP56000ADM	ADM Board for 56000/1
DSP56002ADM	ADM Board for 56002
DSP56004ADM	ADM Board for 56004
DSP56156ADM	ADM Board for 56156
DSP96000ADM	ADM Board for 96000
DSPPCHOST	PC compatible host board and interface software
DSPMACHOST	Macintosh II host board and interface software
DSPSUN4HOST	Sun-4 host board and interface software
DSPCOMMAND	16-, 24-, 32-bit Command Converter board
DSP56004AIB	Audio Interface Board for DSP56004ADS/ADM

2

## DSP Development Tools (continued)

### DSP56156ADS Features

- System commands from within ADS user interface program
- 16K words of configurable static RAM expandable to 64K words

### DSP56000ADS Features

- Host operating system commands from within ADS user interface program
- 8K/32K words of configurable RAM for DSP56000/1 code development
- 96-pin euro-card connector for accessing all DSP56000/1 pins
- 1K words of monitor ROM expandable to 4K words
- Separate connectors for accessing serial or host/DMA ports

### DSP96000ADS Features

- System commands from within ADS user interface program

- 128K words of configurable static RAM expandable to 512K words
- 2K words of EPROM with sockets expandable to 64K words
- Full support of multiple data memory maps
- Two sets of 96-pin connectors provide access to all DSP96002 pins
- 2K words of EPROM with sockets expandable to 16K words
- Full support of multiple data memory maps
- 96-pin connector provides access to all DSP56156 pins

### DSP56KT2 Features

- Full-speed 33 MHz DSP56000/1 emulator in target application with zero wait state external bus accesses
- Direct replacement of the DSP56000ADS and DSP56000EMULTRCABL
- OnCE port on DSP56002 provides dedicated debug port
- Local oscillator for easy evaluation of different target speeds

2

## DSP Development Software Design-In Software Packages

### PART NUMBERS

Simulator/Assembler/ Linker/Library	Host Machine
DSP56100CLASA	IBM PC
DSP56100CLASB	Macintosh II
DSP56100CLASF	Sun-4
DSP56000CLASA	IBM PC
DSP56000CLASB	Macintosh II
DSP56000CLASF	Sun-4
DSP96000CLASA	IBM PC
DSP96000CLASB	Macintosh II
DSP96000CLASF	Sun-4

The Simulator/Macro-Assembler/Linker/Librarian software package is a development system support tool. The Simulator program imitates the operation of the DSP on a clock-cycle by clock-cycle basis and gives an accurate measurement of code execution time. All on-chip peripheral operations, memory and register updates and exception processing activities may be functionally simulated.

The full-featured Macro Cross Assembler translates one or more source files containing instruction mnemonics, operands and assembler directives into a Common Object File Format (COFF) file which is directly loadable by the Simulator. It supports the full instruction set, memory spaces and parallel transfer fields of the DSP.

The Linker relocates and links relocatable COFF object modules from the Assembler to create an absolute load file which can be loaded directly into the Simulator. The Librarian utility will merge separate, relocatable object modules into a single file allowing frequently used modules to be grouped for convenient linking and storing.

The assembler and linker now provide support for assembly language source-level debugging via the simulator. Global symbols, symbols local to sections and even underscore labels may be referenced with all scoping constructs intact. In addition, the assembler generates information about included files and macros. The assembler and linker also support numbered counters ranging from 0 to 65535.

## DSP Development Software (continued)

### C-Compiler Packages

A full ANSI C compliant compiler, based on GNU technology, provides higher efficiency and implements more than 20 major optimization techniques. It has improved in-line assembly capability and an ANSI C preprocessor. The package includes the C Compiler, a new COFF Assembler, Linker, complete ANSI C Libraries and a new C source level debugger as well as expanded user's reference manual. The software package is available for various host computers listed below.

#### PART NUMBERS

GNU C Compiler	Host Machine
DSP56100 Family	
DSP56ICCCA	IBM PC 386
DSP56ICCCF	Sun-4
DSP56000 Family	
DSP56KCCA	IBM PC 386
DSP56KCCF	Sun-4
DSP96000 Family	
DSP96KCCA	IBM PC 386
DSP96KCCF	Sun-4

### C-Compiler Upgrades

Registered users of the earlier versions of the Motorola DSP C compiler can upgrade to the latest GNU C compiler for \$120. To order, contact a Motorola sales representative or distributor. Have your registration number ready.

#### PART NUMBERS

GNU C Compiler	Host Machine
DSP56000 Family	
DSP56KCCAJ	IBM PC
DSP56KCCFJ	Sun-4

2

**2**

# The M68000 Family

## ... the Upward Compatible 8-/16-/32-Bit Microprocessor Family

---

### In Brief . . .

#### An MPU For All Functions

To designers of the most advanced microcomputer systems, the Motorola M68000 Family of microprocessors needs no introduction. Products based on its members have become the standard for systems utilizing the UNIX operating system and for CAD/CAM engineering workstations. They are invading the next generation designs of personal computers and color graphics systems, and they find widespread implementation in multi-user/multi-tasking applications and in small business systems. M68000 MPUs are found in the leading products in fault-tolerant systems requiring high performance and parallel processing, and they are the preferred components for artificial intelligence engines requiring large linear addressing capabilities. Control applications include graphics, numerical controllers, robotics, telecommunications switching and PBX voice/data transmission.

#### Upward Compatibility

The M68000 MPU Family consists of a line of processors based on a 32-bit flexible register set, a large linear address space, a simple yet powerful instruction set and flexible addressing modes. The internal architecture of the 8-, 16-, and 32-bit MPU versions, and the common instruction set, provide software compatibility and offer an easy upward migration path for products requiring increasing levels of processing power.

#### A Host of Peripherals

A large selection of full-function peripheral chips complements the processor family. Compatible LSI and VLSI chips for memory management, data communications, DMA control, network control, system interfacing, general I/O and graphics, all simplify system design and reduce design and manufacturing cost while improving system performance.

	<b>Page</b>
Microprocessors . . . . .	2.2-2
Embedded Controllers . . . . .	2.2-5
Integrated Processors . . . . .	2.2-7
Coprocessors . . . . .	2.2-9
DMA Controllers . . . . .	2.2-9
Network Devices . . . . .	2.2-9
Data Communication Devices . . . . .	2.2-10
General Purpose I/O . . . . .	2.2-11
Fiber Distributed Data Interface . . . . .	2.2-11
Development Tools . . . . .	2.2-12
Support Software . . . . .	2.2-12



# Microprocessors

The 68K Family of Microprocessors has revolutionized virtually every segment of the electronic industry. They have set the standard for performance while still maintaining binary software compatibility from generation to generation. The combination of low cost and high performance (measured in \$/system MIPS) makes every member of the Family a price performance leader. The M68000 Family provides the widest range of price and performance with choices from 1.6 MIPS to over 100 MIPS.

Table 1.

	68000	68020	68030	68040	68060
MIPS	1.6	5.5	12	35	100
MFLOPS	—	0.25	0.5	3.5	15
Address Range	16M Byte	4G Byte	4G Byte	4G Byte	4G Byte
Data Bus	16 bit	32 bit	32 bit	32 bit	32 bit
Clock Speed (MHz)	8–16	16–33	16–50	25–40	50–66
Instruction Cache	—	256 Byte	256 Byte	4K Byte	8K
Data Cache	—	—	256 Byte	4K Byte	8K
Burst Mode	—	—	16 Byte R	16 Byte R/W	16 Byte R/W
General Purpose Registers	16	16	16	16	16
Address Modes	14	18	18	18	18
On-Chip MMU	No	No	Yes	Yes*	Yes*
Floating-Point Solution	68881	68882	68882	On-Chip	On-Chip

\*Separate Instruction/Data

2

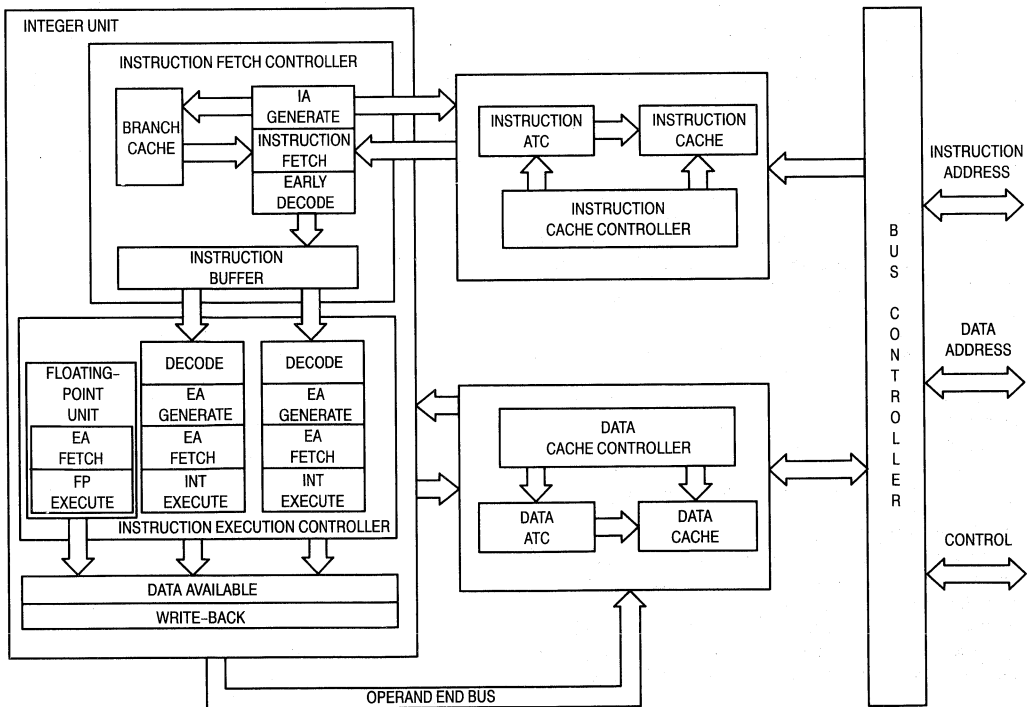

Figure 1. MC68060 Block Diagram

## MC68060

### Superscalar 32-Bit Microprocessor

The MC68060 is fully compatible with all previous members of the M68000 family. The MC68060 features dual on-chip caches, fully independent demand-paged memory management units (MMUs) for both instructions and data, dual integer execution pipelines, on-chip floating-point unit (FPU) and a branch target cache. A high degree of instruction execution parallelism is achieved through the use of a full internal Harvard architecture, multiple internal buses, independent execution units, and dual instruction issue within the instruction controller. Power management is also a key part of the MC68060 architecture. The MC68060 offers a low-power mode of operation that is accessed through the LPSTOP instruction, allowing for full power-down capability. The MC68060 design is fully static so that when circuits are not in use, they do not draw power. Each unit can be disabled so that power is used only when the unit is enabled and executing an instruction.

Complete code compatibility with the M68000 family allows the designer to draw on existing code and past experience to bring products to market quickly. There is also a broad base of established development tools, including real-time kernels, operating systems, languages and applications, to assist in product design. The functionality provided by the MC68060 makes it the ideal choice for a range of high-performance computing applications as well as many portable applications that require low power and high performance.

## MC68040

### Third-Generation 32-Bit Microprocessor

The MC68040 is Motorola's third generation of M68000-compatible, high-performance, 32-bit microprocessors. The MC68040 is a virtual memory microprocessor employing multiple, concurrent execution units and a highly integrated architecture to provide very high performance in a monolithic HCMOS device. On a single chip, the MC68040 integrates an MC68030-compatible integer unit, an IEEE 754-compatible floating-point unit (FPU), and fully independent instruction and data demand-paged memory management units (MMUs), including independent 4K-byte instruction and data caches. A high degree of instruction execution parallelism is achieved through the use of multiple independent execution pipelines, multiple internal buses, and a full internal Harvard architecture, including separate physical caches for both instruction and data accesses. The MC68040 also directly supports cache coherency in multimaster applications with dedicated on-chip bus snooping logic.

The MC68040 is an enhanced, 32-bit, HCMOS microprocessor that combines the integer unit processing capabilities of the MC68030 microprocessor with independent 4K-byte data and instruction caches and an on-chip FPU. The MC68040 maintains the 32-bit registers available with the entire M68000 Family as well as the 32-bit address and data paths, rich instruction set, and versatile addressing modes. Instruction execution proceeds in parallel with accesses to the internal caches, MMU operations, and bus

controller activity. Additionally, the integer unit is optimized for high-level language environments. The MC68040 is user-object-code compatible with previous members of the M68000 Family and is specifically optimized to reduce the execution time of compiler-generated code. The MC68040 is implemented in Motorola's latest HCMOS technology, providing an ideal balance between speed, power, and physical device size.

Instruction execution is pipelined in both the integer unit and FPU. Independent data and instruction MMUs control the main caches and the address translation caches (ATCs). The ATCs speed up logical-to-physical address translations by storing recently used translations. The bus snoop circuit ensures cache coherency in multimaster and multiprocessing applications. The MC68040 FPU is user-object-code compatible with the MC68882 floating-point coprocessor. The FPU has been optimized to execute the most commonly used subset of the MC68882 instruction set, and includes additional instruction formats for single- and double-precision rounding of results.

The MMUs support multiprocessing, virtual memory systems by translating logical addresses to physical addresses using translation tables stored in memory. Each MMU has two transparent translation registers available that define a one-to-one mapping for address space segments ranging in size from 16 Mbytes to 4 Gbytes each. The instruction and data caches operate independently from the rest of the machine, storing information for fast access by the execution units. Each cache resides on its own internal address bus and internal data bus, allowing simultaneous access to both. The data cache provides writethrough or copyback write modes that can be configured on a page-by-page basis.

The MC68040 bus controller supports a high-speed, nonmultiplexed, synchronous external bus interface, which allows the following transfer sizes: byte, word (2 bytes), long word (4 bytes), and line (16 bytes). Line accesses are performed using burst transfers for both reads and writes to provide high data transfer rates.

## MC68030

### The Second Generation 32-Bit MPU

The 030 started with a high performance 020 core and added many performance improvement features including increased internal parallelism, dual on-chip caches with a burst fillable mode, dual internal data and address buses, improved bus interface, and on-chip paged memory management unit.

Two independent 32-bit address buses and two 32-bit data buses allow the CPU, caches, MMU, and the bus controller to operate in parallel, so the 030 can, for example, simultaneously access an instruction from the instruction cache, data from the data cache and instruction/data from external memory.

Performance is further enhanced by on-chip instruction and data caches. Separate 256-byte data and instruction caches reduce the access time and increase CPU throughput by providing data and instructions on-chip.

2

## MC68030 (continued)

Overall bus requirements are reduced and multiple processors can run more efficiently thanks to increased bandwidth of the 030 bus, achieved by the enhanced bus controller allowing high speed fills of both data and instruction caches.

The on-chip paged memory management unit translates logical address to the corresponding physical address in 1/2 the time required by the 020 and MC68851 Paged Memory Management Unit. Pipelining permits this translation to be performed in parallel with other functions so that no translation time is added to any bus cycle.

2

## MC68020 The Original 32-Bit Performance Standard

The MC68020, oh twenty, is the industry's leading 32-bit microprocessor because of high performance, architecture, ease of design-in, and long-range compatible growth path.

The 020 has a full 32-bit internal and 32-bit external, regular, symmetrical architecture designed with the customer in mind. It offers all the functionality of the other M68000 Family MPUs, and maintains software user-code compatibility which controls the expense of your product migration.

Programmers appreciate the large general purpose register set, simple yet powerful instruction set and the many flexible M68000 addressing modes. The unique on-chip instruction cache helps provide burst-mode operation to 12.5 MIPS.

The 020 is the proven leader in high performance systems in office automation, engineering workstations, fault tolerant computers, parallel processors, telephone switching systems, and intelligent controllers.

## MC68010 A Virtual Memory Enhancement

The MC68010 offers the advantage of Virtual Memory. A high-speed loop mode operation executes tight software loops faster to enhance performance. Its instruction continuation feature has made it the choice for fault-tolerant and parallel processing systems. The MC68010 can support a governing operating system which handles the supervisory chores of any number of subordinate operating systems.

## MC68HC000 A Micropower Alternative

HCMOS design gives the MC68HC000 all the functions and performance of its MC68000 predecessors . . . at one-tenth of the operating power requirements. With a maximum power dissipation of only 0.175 watts, the MC68HC000 is ideal for high-performance computer peripherals, industrial controllers, instrumentation and communications equipment.

## MC68HC001 Low Power HCMOS 8-/16-/32-Bit Microprocessor

The MC68HC001 provides a functional extension of the MC68HC000 HCMOS 16-/32-bit microprocessor with the addition of statically selectable 8- or 16-bit data bus operation. The MC68HC001 is object-code compatible with the MC68HC000, and code written for the MC68HC001 can be migrated without modification to any member of the M68000 Family. This is possible because the user programming model is identical for all members of the M68000 Family and the instruction sets are proper subsets for the complete architecture.

## MC68000 The 16-Bit Foundations

As the first member of the M68000 family, the state-of-the-art technology and advance circuit design concepts of the MC68000 16-bit MPU started a new trend in microprocessor architecture. Its seventeen 32-bit data and address registers permit rapid internal execution of its powerful yet simple instruction set. It is designed for large multiprocessing systems and realtime applications with vectored interrupts, seven priority levels and a 16 megabyte linear addressing space. It offers mainframe-like performance, supporting high-level languages and sophisticated operating systems.

The MC68000 MPU has been joined by more advanced products with even greater capabilities, yet it satisfies a large segment of the existing applications. It is extremely cost competitive and it remains one of the major growth products in the entire MPU line.

## MC68008 An 8-Bit Compatible Competitor

With an 8-bit data bus and 32-bit internal architecture, the MC68008 offers performance that competes with a number of 16-bit MPUs. It has the same register set, same instructions, and the same functionality as the MC68000 with extensive exception processing. Large modular programs can be developed and executed efficiently because of the large, 1-megabit non-segmented, linear address space. It is the choice for high performance, cost effective, 8-bit designs, particularly those requiring a migration path to 16-bit or full 32-bit operation.

# Embedded Controllers

The principle elements of this popular microprocessor family have now been redesigned specifically for embedded applications. The new 68EC0x0 family including the 68EC000, EC020, EC030 and EC040 MPUs are all optimized for cost-sensitive embedded control designs. The 68EC0x0 family offers the high performance of the 680x0 family, yet streamlines the feature sets for embedded applications. The 68EC0x0 family completes the triad forming the M68000 family of compatible products: the 680x0 family of computer-class central processing units; the 68300 family of integrated processors; and now, the 68EC0x0 family of embedded microprocessors.

**Table 2.**

	<b>68EC000</b>	<b>68EC020</b>	<b>68EC030</b>	<b>68EC040</b>
MIPS	2.5	6.5	10.7	29
Address Range	16M Byte	16M Byte	4G Byte	4G Byte
Data Bus	16 bit	32 bit	32 bit	32 bit
Clock Speeds	8, 10, 12, 16 MHz	16, 25 MHz	25, 40 MHz	20, 25, 33* MHz
Instruction Cache	-	256 Byte	256 Byte	4K Byte
Data Cache	-	-	256 Byte	4K Byte
Burst Fill Caches	-	-	16 Bytes	16 Bytes
General Purpose Registers	16	16	16	16
Address Modes	14	18	18	18
Floating Point Hardware	68881/68882	68881/68882	68881/68882	68040
Packages	PLCC	PPGA, PQFP	PPGA, CQFP	PGA, CQFP*

\* Available in the future

## MC68EC040 32-Bit High-Performance Embedded Controller

The 68EC040 is the newest addition to Motorola's embedded microprocessor family. It is the performance leader for top-of-the-line embedded applications. The EC040 is capable of delivering 29 MIPS of sustained performance at 1.2 cycles per instruction with a system cost that is unattainable by competing architectures.

This impressive performance is a result of a six-level pipelined integer unit, independent four-way set-associative instruction and data caches, and a very high level of on-chip parallelism. The EC040 also supports multimaster and multiprocessor systems with bus snooping.

By integrating all these features into the EC040, the microprocessor is able to perform the vast majority of work on-chip, limiting external memory accesses to allow for higher system performance with less expensive DRAMs. The result is virtual immunity to the effects of memory wait states.

**2**

### MC68EC030

#### 32-Bit Enhanced Embedded Controller

The MC68EC030 is a 32-bit embedded controller that streamlines the functionality of an MC68030 for the requirements of embedded control applications. The MC68EC030 is optimized to maintain performance while using cost-effective memory subsystems. The rich instruction set and addressing mode capabilities of the MC68020, MC68030, and MC68040 have been maintained, allowing a clear migration path for M68000 systems. The MC68EC030 is object-code compatible with the MC68020, MC68030, and earlier M68000 microprocessors. Burst-mode bus interface is provided for efficient DRAM access.

The MC68EC030 has an on-chip data cache and on-chip instruction cache with 256 bytes each. Dynamic bus sizing is available for direct interfacing to 8-, 16-, and 32-Bit Devices. The MC68EC030 includes 32-bit nonmultiplexed address and data buses, sixteen 32-bit general-purpose data and address registers, and two 32-bit supervisor stack pointers and eight special-purpose control registers. The EC030 provides complete support for coprocessors with the M68000 coprocessor interface. There are two access control registers that allow blocks to be defined for cacheability protection. The pipelined architecture, along with increased parallelism, allows internal caches accesses in parallel with bus transfers and overlapped instruction execution. The enhanced bus controller supports asynchronous bus cycles (three clocks minimum), synchronous bus cycles (two clocks minimum), and burst data transfers (one clock).

### MC68EC020

#### 32-Bit Embedded Controller

The 68EC020, with a complete 32-bit internal implementation, has a 32-bit data bus and an on-chip instruction cache to provide dramatically increased performance over 8- and 16-bit microprocessors. In addition, upward migration to the EC020 is made simple with dynamic bus sizing, allowing 8, 16 and 32-bit peripherals to communicate with the microprocessor.

Other performance features include advanced bit manipulation capabilities that provide multiple bit shift operations in a single instruction cycle. This capability greatly simplifies and accelerates the bit operations required in graphics processing and optical recognition applications.

### MC68EC000

#### Low-Powered HCMOS Embedded Controller

The 68EC000 is a low-power HCMOS derivative of the 68000 optimized for cost-effective embedded processing. The EC000 has a flexible data bus that can operate in either 8- or 16-bit modes and a 24-bit address bus that provides 16 Mbytes of memory addressing capability. Electrical characteristics of the 68EC000 have been optimized to ensure easy access to low-cost memories.

The 68EC000 represents the lowest cost entry point to any 32-bit architecture. Coupled with efficient support for high-level languages and real-time operating systems, the 68EC000 provides unparalleled compatible migration paths to higher performance.

2

# Integrated Processors

Powerful solutions to cost-, space-, and power-sensitive embedded applications are provided by the 68300 family of integrated microprocessors and microcontrollers. The 68300 family combines two of Motorola's greatest strengths — the 32-bit microprocessor architecture of the 68000 family and a proliferation of peripheral circuits offering a growing family of integrated solutions.

The 68000 family is based on a proven, expandable architecture that spans the performance range from 1 to over 29 MIPS. This architecture offers the industry's highest level of compatibility for both hardware and software. Motorola's single-chip microcomputers and microcontrollers provide the industry's broadest selection of peripheral combinations, insurance that one will fit the need of practically any application. The 683000 family embraces both of these concepts.

Each member of the 68300 family contains a core processor based on the 68000 family, a System Integration Module (SIM), an on-chip bus and various peripheral modules. The SIMs include support circuitry such as a clock generation, external chip selects, system protection, timers and JTAG. The on-chip intermodule bus (IMB) on the CPU-based 68300s creates a standard interface over which the CPU and each of the modules communicate. The peripheral modules include specialized processors, system controllers, traditional peripherals and memory. Because the peripheral modules are independent from each other, they can appear in multiple 68300 devices. With so many major features incorporated into a single 68300 device, a system designer can realize improved reliability along with significant savings in design time, power consumption, cost, board space, pin count and program development. In a 68300 device, the major functions and glue logic are all properly connected, internally timed with the same fast clock, fully tested and consistently documented.

2

**Table 3.**

	68302	68306	68330	68331	68332	68333	68334	68340
Core Processor	68000	680EC00	CPU32	CPU32	CPU32	CPU32	CPU32	CPU32
Speeds (MHz)	16, 20	16	16, 25	16	16	16	16	16, 25
DMA	Yes	—	—	—	—	—	—	Yes
Serial Processor	Yes	—	—	—	—	—	—	—
Time Processor Unit	—	—	—	—	Yes	Yes	Yes	—
Flash EEPROM	—	—	—	—	—	64K	—	—
Serial I/O	Yes	Yes	—	Yes	Yes	Yes	—	Yes
Timers	1	—	—	1	—	—	—	2
A/D Converter	—	—	—	—	—	Yes	Yes	—
SRAM	1K	—	—	—	2K	4K	1K	—
DRAM Controller	—	Yes	—	—	—	—	—	—
Glue Logic (SIM)	Yes	Yes	Yes	Yes	Yes	Yes	Yes	Yes
3.3 Volts Available	—	—	—	—	—	—	—	Yes

## MC68302 Integrated Multiprotocol Processor

The MC68302 integrated multiprotocol processor (IMP) is a very large-scale integration (VLSI) device incorporating the main building blocks needed for the design of a wide variety of controllers used in the communications industry. The IMP is the first device to offer the benefits of a closely coupled, industry-standard M68000/MC68008 microprocessor core and a flexible communications architecture. The three-channel communications device may be configured to support a number of popular industry interfaces, including those for the Integrated Services Digital Network (ISDN) basic rate and terminal adaptor applications. Through a

combination of architectural and programmable features concurrent operation of different protocols (HDLC/SDLC™, UART, BISYNC, DDCMP™, or transparent modes) can easily be achieved. Data concentrators, modems, line cards, bridges, and gateways are examples of suitable applications for this device.

The IMP is a Complementary Metal-Oxide Semiconductor (CMOS) device consisting of an M68000/MC68008 microprocessor core, a system integration block (SIB), and a Communications Processor (CP). By integrating the microprocessor core with the serial ports (in the CP) and the system peripherals (in the SIB), the IMP is capable of handling complex tasks such as all ISDN basic rate (2B+D) access tasks.

## Integrated Processors (continued)

### MC68306

#### Integrated 68EC00 Processor

The 68306 integrated EC000 processor includes many of the features commonly found in 68000-based designs. The 68306 includes a 68EC000 core processor, a 68681 Dual Universal Asynchronous Receiver Transmitter (DUART), system integration functions, and a DRAM controller. The on-chip DRAM controller gives the 68306 the family's simplest interface to DRAM-based designs. The DRAM controller easily accommodates 64 Mbytes of memory. The 68306 saves time in the design cycle by providing valuable 68000 system components pre-packaged in one chip.

### MC68330

#### Integrated CPU32 Processor

The 68330 is ideal for applications requiring 32-bit microprocessor performance without the additional expense inherent in 32-bit memory systems. The 68330 is the simplest and lowest priced member of the CPU32-based 68300 family. The 68330 allows the designer access to the high performance of the CPU32 along with minimized external glue logic, while allowing the greatest freedom in selecting needed peripherals, ASICs or gate arrays.

### MC68331

#### 32-Bit Microcontroller

The 68331 is well suited to applications requiring simple serial communications and general timing needs. The 68331 contains the CPU32, a SIM, a General Purpose Timer (GPT) and a Queued Serial Module (QSM). The general purpose timer is a simple yet flexible timer that provides four modes of operation with multiple channels for some operations. The QSM provides two modes of communication: an asynchronous channel that provides up to 524-Kbits per second transfer rate and a serial peripheral interface with separate 16-word receive/transmit queues.

### MC68332

#### 32-Bit Microcontroller

The 68332 is especially suited for high-performance timing applications such as automotive engine control, precision motor control and industrial robotics. The powerful Time Processor Unit (TPU) distinguishes the 68332 providing optimum performance in controlling time-related activity. It drastically reduces the need for CPU intervention with its dedicated execution unit, tri-level prioritized scheduler, data

storage RAM and dual time bases. In addition to the TPU and CPU32, the 68332 features the QSM, a SIM and 2-Kbytes of standby static RAM.

### MC68F333

#### 32-Bit Microcontroller

The 68F333 provides the highest level of integration available to high-performance timing applications such as avionics and automotive engine control. The 68F333 contains the CPU32, the TPU and the QSM. It also adds two banks of flash EEPROM totaling 64-Kbytes, a total of 4-Kbytes of SRAM (512 bytes separately powered) and an 8-channel, 10-bit analog-to-digital converter. The Single-Chip Integration Module (SCIM) allows 18 of the external address and data pins to be converted to I/O pins, resulting in a single-chip solution suitable for many applications.

### MC68334

#### 32-Bit Microcontroller

The 68334 is a streamlined version of the 68332, taking advantage of the powerful TPU. The 68334 includes the CPU32 core processor, the TPU, a SIM, 1-Kbyte of SRAM, a 10-bit analog-to-digital converter and up to 47 discrete I/O lines.

### MC68340

#### Integrated Multiprotocol Processor with DMA

The 68340 is excellent for applications requiring high-speed or block data transfers, such as disk drives and navigation systems. The combination of general peripherals and the extremely low power consumption possibilities of the 68340 make it ideal for many battery powered, portable applications such as hand held computers and data acquisition systems.

The most distinguishing 68340 feature is the high speed two channel, 32-bit Direct Memory Access (DMA) controller. Incorporating the CPU32 and DMA on the same chip eliminates the usual bus arbitration and synchronization delays, maximizing data throughout (25-Mbytes per second on a 16-bit bus).

In addition to the CPU32, a SIM and the DMA, the 68340 contains a 68681/2681-compatible DUART. The 68340 also has two identical, versatile counter/timers, each with a 16-bit counter and an 8-bit prescaler with 80 ns resolution.

2

## Coprocessors

### MC68851

#### Paged Memory Management Unit, PMMU

The PMMU is a 32-bit memory manager which provides full support for a demand paged virtual environment with the 68010 or MC68020. It supports a 4-gigabyte addressing space when used as a coprocessor with the MC68020. An on-chip address translation cache minimizes translation delays and maximizes system performance.

### MC68881

#### A Floating Point Coprocessor

Designed specifically for arithmetic expansion of the MC68020 MPU, this powerful coprocessor can also be used as a peripheral to all other M68000 family members, and with non-M68000 processors as well. It performs floating point math calculations in strict conformance to a full implementation of the IEEE Standard for Binary Floating Point Arithmetic (754) and, in addition to the basic add, subtract, multiply, and divide functions, it handles full selection of transcendental and non-transcendental operations. These operations include root values, trigonometric functions, exponentials, hyperbolics, and logs. All functions are calculated to 80 bits of extended precision in hardware.

### MC68882

#### Enhanced Floating Point Coprocessor

The MC68882 is pin-to-pin hardware and software compatible with the MC68881 Floating Point Coprocessor and implements a variety of performance enhancements including dual-ported registers and an advanced pipeline. Additional circuitry allows execution of multiple instructions in parallel for more than twice the Floating Point performance of the trail-blazing MC68881. Where higher performance requirements indicate, the MC68882 is a drop-in replacement for the MC68881.

## DMA Controllers

### MC68450

#### DMA Controller, DMAC

The DMAC maintains high-performance data movement for complex M68000 MPU-based systems. While pin compatible with the MC68440 DDMA, the DMAC offers four completely independent DMA channels. In addition to all the features of the DDMA, the DMAC also provides very sophisticated manipulation of data through sequential and linked array-chained addressing capabilities.

### MC68440

#### Dual Direct Memory Access Controller, DDMA

The DDMA complements the performance capabilities of M68000 microprocessors by moving blocks of data in a quick, efficient manner with a minimum of intervention from the MPU. The DDMA performs memory-to-memory, peripheral-to-memory, and memory-to-peripheral transfers through each of two completely independent DMA channels. The DDMA also offers two interrupt vectors per channel and supports both 8-bit and 16-bit data transfers.

## Network Devices

2

### MC68824

#### Token Bus Controller, TBC

The TBC is the industry's first single-chip VLSI device to implement the IEEE 802.4 Media Access Control Sublayer of the ISO Data Link Layer, as specified by General Motors Manufacturing Automation Protocol, MAP. The TBC supports serial data rates of 1, 5, and 10 Mbps and relieves the host processor of the frame formatting and token management functions. For efficient transfer of data frames, to and from memory, the TBC features an on-chip four-channel DMA with bus master capability, a 32-bit address range, an 8- or 16-bit data bus, and a 40-byte FIFO. The MC68824 also offers support options for network bridges, real-time support and network monitoring services.

### MC68184

#### Broadband Interface Controller

The MC68184 Broadband Interface Controller (BIC) is a high-performance interface device for use with the MC68824 Token Bus Controller (TBC) to implement the digital portion of the physical layer of a broadband IEEE 802.4 token bus node. The BIC manipulates both data and control for RF transmitter circuitry and RF receiver circuitry. The CMOS BIC supports data rates up to 10 Mbps using a duo-binary modulation technique and provides 20 lines for receiver/transmitter control with 13 user-defined outputs.

The BIC performs the digital functions of the physical layer when implementing a broadband token bus node. The modem side of the BIC provides data and control for the RF transmitter/receiver circuitry. A standard serial interface is used to connect the BIC to the MC68824 TBC. The TBC performs the media access control (MAC) function. The MC68184 has the ability to scramble and descramble data.

### MC68185

#### Twisted-Pair Modem

The MC68185 Twisted-Pair Modem (TPM) is used in conjunction with a MC68824 Token Bus Controller (TBC), an RS485 transceiver, and a twisted-pair media to implement a



## Network Devices: MC68185 — Twisted-Pair Modem (continued)

low-cost area network (LAN). The MC68824 TBC implements the layer 2 media access control (MAC) portion of the IEEE 802.4 LAN station and receiver portion for the IEEE 802.2 logical link control (LLC) type 3 as well as providing support for LLC type 1 and type 2. The TPM interfaces directly to the TBC, providing physical layer management, including MAC symbol encoding/decoding at data rates up to 2 Mbps.

The TPM contains an 32 kHz to 20 MHz on-chip crystal oscillator that generates a transmit clock without external circuitry. The physical layer management includes local loopback mode, transmitter enable, and reset. An on-chip digital filter provides for noise reduction of received data.

2

### MC68194

#### Carrierband Modem

The bipolar LSI MC68194 Carrierband Modem (CBM), when combined with the MC68824 Token Bus Controller (TBC), provides an IEEE 802.4 single-channel, phase-coherent carrierband, Local Area Network (LAN) connection. The CBM performs the physical layer function, including symbol encoding/decoding, signal transmission and reception, and physical management.

The CBM provides the three basic functions of the physical layer: data transmission to the coaxial cable, data reception from the cable, and management of the physical layer. For standard data mode (also called MAC mode), the CBM receives a serial transmit data stream from the TBC (called symbols or atomic symbols), encodes, modulates the carrier, and transmits the signal to the coaxial cable. Also in the data mode, the CBM receives a signal from the cable, demodulates the signal, recovers the data, and sends the received data symbols to the TBC. End-of-transmission receiver blanking as required by IEEE 802.4 is supported. Communication between the TBC and CBM is through a standardized serial interface consistent with the IEEE 802.4 DTE-DCE interface.

### MC68195

#### Local Talk Adaptor

The MC68195 LocalTalk adaptor (LA) is used in conjunction with the MC68302 Integrated Multiprotocol Processor (IMP) to build a network interface to LocalTalk™, also known as AppleTalk™. LocalTalk refers to the 230.4-kbps Local Area Network (LAN) that connects multiple Macintosh™ computers and printers.

The LA provides LocalTalk support for any two of the three IMP serial channels. Combinations of multiple LA and/or IMP devices may be used to support additional LocalTalk channels. Non-LocalTalk applications can use the LA device with the IMP to build proprietary HDLC-based LANs at up to 2.5 Mbps using bi-phase space (FMO) encoding.

### MC68605

#### X.25 Protocol Controller, XPC

The XPC implements the 1984 CCITT X.25 Recommendation Data Link Procedure (level 2) LAPB. In addition to handling the lower level communications functions (HDLC framing, CRC generation/checking, and zero insertion/deletion), the XPC also independently handles higher level communications functions (frame sequencing, retransmission, flow control, retries limit and timeout conditions). This allows the host to operate almost totally isolated from the task of ensuring error-free transmission and reception of data.

### MC68606

#### Multi-Link LAPD Controller CCITT Q.920/Q.921, LAPD

The MC68606 Multi-link LAPD (MLAPD) Protocol Controller fully implements CCITT Recommendation Q.920/Q.921 Link Layer Access Procedure (LAPD) protocol for ISDN networks. The MLAPD is designed to handle both signalling and data links in high-performance ISDN primary rate applications.

This VLSI device provides a cost-effective solution to ISDN link-level processing with simultaneous support for up to 8K logical links. The MC68606 is an intelligent communications protocol controller compatible with AT&T specifications for ISDN devices and features low power consumption and high performance, with an aggregate data rate in excess of 2.048 Mbps.

## Data Communication Devices

### MC68681

### MC2681

#### Dual Universal Asynchronous Receiver/Transmitter, DUART

The MC68681 features two completely independent full-duplex asynchronous receiver/transmitter channels that interface directly to the M68000 microprocessor bus. Receiver data registers are quadruple buffered and transmitter data registers are double buffered for minimum MPU intervention. Each has its own independently selectable baud rate. Multifunction 6-bit input port and 8-bit output port, a 16-bit programmable counter/timer, interrupt handling capabilities, and a maximum one-megabyte per second transfer rate make the DUART an extremely powerful device for complex data communication applications. Full device functionality with an M6800 bus interface is provided by the MC2681.

## General Purpose I/O

### MC68230

#### Parallel Interface/Timer, PI/T

The PI/T provides versatile double-buffered parallel interfaces and a system-oriented timer for M68000 systems. The parallel interfaces operate either in a unidirectional or bidirectional mode, either 8- or 16-bit wide. The timer is 24 bits with full programmability and a 5-bit prescaler. The PI/T has a complete M68000 bus interface and is fully compatible with the MC68450 DMAC.

### MC68901

#### Multifunction Peripheral, MFP

The MFP provides basic microcomputer function requirements as a single companion chip to the M68000 Family of Microprocessors. Features provided via a direct M68000 system bus interface include a full-function, single-channel Universal Serial Asynchronous Receiver/Transmitter (USART) for data communication, an 8-source interrupt controller, eight parallel I/O lines, and four 8-bit timers.

## Fiber Distributed Data Interface

Fiber Distributed Data Interface (FDDI) is defined as a dual fiber-optic token ring LAN (Local Area Network) that can support rates up to 100 Mbps. It can accommodate rings with 1,000 stations. Two kilometers between stations, and up to 200 kilometers in total length. This technology is driven by the need to support high performance distributed computer systems which are becoming faster and more powerful, thus imposing a greater need for network speed and bandwidth. Other uses for FDDI include backbone networks connecting Ethernet, Token Bus, and Token Ring segments and back end networks connecting high-speed peripherals. FDDI is an American National Standards Institute (ANSI) standard. Motorola's FDDI chip set includes the MC68836, MC68837, MC68838, and MC68839.

### MC68836

#### FDDI Clock Generator

The MC68836 FDDI Clock Generator (FCG) implements part of the Physical Layer (PHY) functions of the FDDI standard including clock recovery, data recovery, and NRZI

conversions. The FCG also does a five-bit parallel to serial conversion during transmission, and a serial to five-bit parallel conversion during reception. The FCG uses the five-bit parallel interface to communicate with the MC68837 device. The FCG directly connects to fiber optic modules through differential driver/receiver pins. Features include full duplex operations, 125 MHz clock recovery from incoming serial NRZI data stream, and 125 MHz transmit clock generation.

### MC68837

#### Elasticity Buffer and Link Manager

The Elasticity Buffer and Link Manager (ELM) implements the remaining of the PHY functions of the FDDI standard including data framing, elasticity buffer, encoding, decoding, smoothing, line state detection, and repeat filter. The ELM also implements some Station Management (SMT) functions such as the Connection Management (CMT), Physical Connection Management (PCM), Physical Connection Insertion (PCI), and Link Error Monitor (LEM).

### MC68838

#### Media Access Controller

The Media Access Controller (MAC) implements the MAC portion of the FDDI standard. The MAC protocol is the lower sub-layer of the ISO OSI data link layer and provides for fair and deterministic sharing of the physical medium, address recognition, frame check sequence generation and verification, frame insertion, frame repetition, frame removal, token generation, and certain error recovery procedures. Features on the MC68838 include independent receive and transmit data paths and state machines, bridging support including a bit order reversal option, a count and void frame bridge stripping algorithm, and CRC appendage on a per frame basis. The MAC also contains an interface to Content Addressable Memory (CAM) for individual and multicast address recognition.

### MC68839

#### FDDI System Interface

The FDDI System Interface (FSI) is a high performance interface device which can easily connect to any bus including high speed processors, little- and big-endian busses, and multiplexed/non-multiplexed address data busses. Its primary purpose is to interface the FDDI protocol devices to the user system bus. FSI features include support for a ring buffer structure, addressing flexibility, programmable partitioned 8K bytes internal RAM for temporary data storage, two 32-bit ports, the ability to sustain up to 250  $\mu$ s bus latencies, support for synchronous and asynchronous frames, and the ability to chain multiple buffers per frame.

2

# Development Tools

## Application Development System

The M68302ADS is a stand-alone board developed by Motorola that includes software modules (driver code, LAPB, LAPD, and X.25), a real-time kernel, and a monitor/debugger. The board consists of the MC68302, memory (512K bytes of RAM expandable to 1M bytes, 256 bytes of EPROM and EEPROM), and an MC68681 DUART (to allow all MC68302 serial ports to be available to the user). It is an inexpensive, ideal platform for software development and testing.

to support each CPU module. The IDP also includes two software debug monitor programs: Integrated Systems' ROM68K™ and Intermetrics' SmartROM™. This configuration allows the user to take advantage of an entire suite of features, including tracing, assembling, disassembling and downloading, that are offered by the monitors. Optional software is available to expand the development environment of the IDP by allowing the user to design, debug and evaluate the M68000 microprocessor-based applications in real-time and non-real-time operating system environments. The IDP also functions as a tool for final test or fault analysis of user target systems.

The IDP only requires a user-supplied power supply and an RS-332 ASCII terminal or host computer with an RS-232 serial port. Although the IDP will function using a terminal, the preferred communication device is a host computer. Operating the IDP with a host computer allows the user to develop, compile and debug code using one of many optional software tools. Once code is developed, the program can be saved and downloaded to the IDP from the host computer.

## M68340EVS

### Evaluation System

The M68340EVS is an inexpensive three-board evaluation and development system which allows the user to design, debug and evaluate 68340-based applications. It interfaces easily to traditional emulation tools and includes its own software debugger.

## M68040FPSP

This software provides 68040 floating point emulation of unimplemented 68881/68882 functions. Contact factory for license agreement.

# Support Software

## M68KESW-PC1

This Intermetrics software package is for the 68K Family (68000, 68008, 68HC001, 68010, 68020, 68030, 68EC030, 68040, 683xx). The M68KESW InterTools package includes C compiler, assembler/linker, run-time libraries, and one year of support from Intermetrics.

Table 4. Selector Guide

Device Number	Package	Speeds	Device Type
MC68000	64-Lead L*, P 68-Lead R, RC*, FN	8, 10, 12, 12F* 8, 10, 12, 12F*	Microprocessor
MC68EC000	68-Lead FN	8, 10, 12, 16	Embedded Controller
MC68HC000	64-Lead P 68-Lead R, RC*, FN 68-Lead FC	8, 10, 12, 12F*, 16 8, 10, 12, 16 8, 10, 12, 16	Microprocessor
MC68HC001	68-Lead R, RC*, FN	8, 10, 12, 16	
MC68008	48-Lead P 52-Lead FN	8, 10 8, 10	Microprocessor
MC68010	64-Lead P 68-Lead R, RC*, FN	8, 10, 12 8, 10, 12	Microprocessor

\* Not recommended for new design  
All package/speed combinations may not be valid - consult factory to verify

2

## M68EC0x0IDP

### Evaluation Boards for Embedded Controllers

The M68000 family IDP is a board set designed to provide a low-cost evaluation platform, yet flexible environment for developing both software and hardware for the family products. The platform provides the means for M68000 microprocessor and tool evaluation which enables users to properly select the microprocessor and associated tools for their next application. Because the turnkey development system requires the user to do very little to power up the system and begin development, significant time savings is realized by reducing the overall time that the product takes to get to market.

The IDP consists of an M68000 Family microprocessor-based CPU module as well as a generic IDP motherboard designed

**Table 4. Selector Guide (continued)**

Device Number	Package	Speeds	Device Type
MC68020	114-Lead RC 132-Lead FE* 114-Lead RP 132-Lead FC	12, 16, 20, 25, 33 16, 20, 25 16, 20, 25 16, 20, 25	Microprocessor
MC68EC020	100-Lead FG, RP	16, 25	Embedded Controller
MC68030	128-Lead RC 124-Lead RP 132-Lead FE	16, 20, 25, 33, 40, 50 16, 20, 25, 33 16, 20, 25, 33	Microprocessor
MC68EC030	124-Lead RP 132-Lead FE	25, 40 25, 40	Embedded Controller
MC68040	179-Lead RC	25, 33, 40	Microprocessor
MC68EC040	179-Lead RC 184-Lead FE	20, 25, 33 20, 25	Embedded Controller
MC68LC040	179-Lead RC 184-Lead FE	20, 25, 33 20, 25	Microprocessor
MC68040V	184-Lead FE	25, 33	Microprocessor
MC68060	223-Lead RC TBD-Lead FE	50, 66 50, 66	Microprocessor
MC68184	40-Lead P, I	-	Network
MC68185	44-Lead FN 68-Lead RC	- -	Network
MC68194	52-Lead FJ	-	Network
MC68195	44-Lead FN	-	Network
MC68230	48-Lead P 52-Lead FN	8, 10 8, 10	General Purpose I/O
MC68302	132-Lead RC, FE, FC, FD	16, 20	Integrated Processor
MC68306	128-Lead FC 132-Lead FG	16 16	Integrated Processor
MC68330	132-Lead FC	16, 25 8, 16 @ 3.3 V	Integrated Processor
MC68331	132-Lead FC	16	Integrated Processor
MC68332	132-Lead FC	16	Integrated Processor
MC68340	144-Lead FE 145-Lead RP	16, 25 16, 25	Integrated Processor
MC68340V	144-Lead FE 145-Lead RP	8, 16 @ 3.3 V 8, 16 @ 3.3 V	Integrated Processor
MC68360	240-Lead FC 241-Lead RC	0 - 25 0 - 25	Integrated Communication Controller
MC68440	68-Lead L, P 68-Lead R, FN	8, 10 8, 10	DMA Controller
MC68450	68-Lead L, P 68-Lead R, FN	8, 10 8, 10	DMA Controller
MC68605	84-Lead R, RC 84-Lead FN	10, 12, 16 10, 12, 16	Network
MC68606	84-Lead RC 84-Lead FN	12, 16 12, 16	Network

\* Not recommended for new design  
All package/speed combinations may not be valid - consult factory to verify

**2**

**Table 4. Selector Guide (continued)**

Device Number	Package	Speeds	Device Type
MC2681	40-Lead P, L* 44-Lead FN	— —	Data Communication
MC68681	40-Lead P, L* 44-Lead FN	— —	Data Communication
MC68824	84-Lead R, RC 84-Lead FN	10, 12, 16 10, 12, 16	Network
MC68836	52-Lead FN	—	Fiber Distributed Data Interface
MC68837	120-Lead KB 120-Lead FC	— —	Fiber Distributed Data Interface
MC68838	120-Lead KB 120-Lead FC	— —	Fiber Distributed Data Interface
MC68839	184-Lead RC 184-Lead FE	— —	Fiber Distributed Data Interface
MC68851*	132-Lead RC	12, 16, 20	CoProcessor
MC68881	68-Lead RC, FN	12, 16, 20	CoProcessor
MC68882	68-Lead RC 68-Lead RN	16, 20, 25, 33, 40, 50 16, 20, 25, 33, 40	CoProcessor
MC68901	48-Lead P 52-Lead FN	— —	General Purpose I/O
FC = Plastic Quad (Gull Wing)      FN = Plastic Quad Pack (PLCC)      P = Plastic DIP FD = Plastic Quad w/Molded Carrier Ring      KB = Ceramic PGA w/Ceramic Lid      R = Pin Grid Array, Solder Lead Finish FE = Ceramic Quad (Gull Wing)      L = Ceramic DIP      RC = Ceramic PGA, Gold Lead Finish FG = Plastic Quad Flat Pack (PQFP)      LC = Ceramic DIP, Gold Lead Finish      RP = Plastic Pin Grid Array			

\* Not recommended for new design  
 All package/speed combinations may not be valid – consult factory to verify

**2**

# The M88000 RISC Family

---

## In Brief . . .

Motorola's 88000 Family comes from the only company committed to long-term upward software compatibility through such features as hardware interlocked and protected pipelines. Our goal is to make sure each generation of the 88000 RISC family delivers a high performance level while maintaining software compatibility.

	<b>Page</b>
Architecture, Performance, and Software Compatibility . . . . .	2.3-2
Microprocessors . . . . .	2.3-2
Cache/Memory Management Units . . . . .	2.3-3

# Motorola's 88000 RISC Microprocessors

... a performance architecture

## Architecture, Performance, and Software Compatibility

The 88000 RISC was designed from the start for superscaler implementations. In fact, the design of the second generation 88110 microprocessor is a unique superscaler implementation called Symmetric Superscalar™. The Symmetric Superscaler design allows you to execute multiple instructions in a single clock cycle without any restrictions on instruction ordering. So there are no wait states or performance penalties because of out of order instructions.

Also, while other RISC microprocessors may be limited in the instructions they can execute in a single clock cycle, members of the 88000 are able to execute multiple instructions per clock cycle, thus providing the performance edge required for next generation system designs.

## Performance Plus Software Compatibility

Although high performance is recognized as a key feature for systems design, software compatibility is also important. Motorola's 88000 Family comes from the only company committed to long term upward software compatibility through such features as hardware interlocked and protected pipelines. Our goal is to make sure each generation of the 88000 RISC family delivers a high performance level while maintaining software compatibility. This gives the opportunity for designing one of the industry's highest performance systems, while leveraging your largest dollar investment in new systems, your software.

Software compatibility is also promoted through standards to provide an open systems environment benefitting system companies, software developers, and end users because 88000 based systems from different vendors will run all of the same software.

## Microprocessors

### MC88100RC

#### 32-Bit RISC Microprocessor

The MC88100 is the first processor in the 88000 Family of RISC (reduced instruction set computer) microprocessors. Implemented with Motorola's HCMOS technology, the MC88100 incorporates 32-bit registers, data paths, and addresses. In designing the MC88100, Motorola has incorporated a high degree of fine-grain parallelism; four independent execution units maintain separate, fully concurrent execution pipelines. Most instructions operate in one machine cycle or effective concurrent execution can be accomplished through internal pipelines in one machine cycle.

A common register file provides data sharing and synchronization control among the execution units through register scoreboarding.

The MC88100 addresses a variety of applications requiring high operational speeds and efficient, fast-execution architectures. All data manipulation instructions are nondestructive register to register or register with immediate operations, allowing both fast operand access and operand reuse. IEEE 754 floating-point arithmetic is supported in the processor. Instruction and data memory space are accessed through separate memory ports, allowing simultaneous access to dedicated memory areas. The 88000 Family includes the MC88200 CMMU (cache/memory management unit), which adds high-speed memory caching, two-level, demand-paged memory management, and support for shared-memory multiprocessing. The 88000 Family also includes a full line of highly optimizing compilers, operating systems, development boards, and development tools.

### MC88110RC

#### 32-Bit RISC Microprocessor

The MC88110 is the second implementation of the 88000 family of reduced instruction set computer (RISC) microprocessors. The MC88110 is a Symmetric Superscalar machine capable of issuing and retiring two instructions per clock without any special alignment, ordering, or type restrictions on the instruction stream. Instructions are issued to multiple execution units, execute in parallel, and can complete out of order, with the machine automatically keeping results in the correct program sequence. The Symmetric Superscalar design allows sustained performance to approach the peak performance capability.

The MC88110 uses dual instruction issue and simple instructions with extremely rapid execution times to yield maximum efficiency and throughput for 88000 systems. Instructions either execute in one clock cycle, or effective one clock cycle execution is achieved through internal pipelining. Ten independent execution units communicate with a general register file and an extended register file through multiple 80-bit internal buses. Each of the register files has sufficient bandwidth to supply four operands and receive two results per clock cycle. Each of the pipelined execution units, including those that execute floating-point and data movement instructions, can accept a new instruction and retire a previous instruction on every clock cycle.

In a single chip implementation, the MC88110 integrates the central processing unit, floating point unit, graphics processing unit, virtual memory address translation, instruction cache, and data cache. The MC88110 maintains compatibility with MC88100 user application software.

2

# Cache/Memory Management Units

## MC88200RC

### 16-Kilobyte Cache/Memory Management Unit (CMMU)

The MC88200 CMMU is a high-performance, HCMOS VLSI device providing zero-wait-state memory management and data caching. The MMU (memory management unit) efficiently supports a demand-paged virtual memory environment with two logical address ranges (user/supervisor) of 4 gigabytes each. Translated addresses are provided by one of two ATCs (address translation caches), providing address translation in one clock cycle for most memory accesses. The PATC (page address translation cache) is a 56-entry, fully associative cache containing recently used translations for 4-kilobyte memory pages and is maintained by MC88200 hardware. The BATC (block address translation cache) is a 10-entry cache, loaded by software, containing translations for 512-kilobyte memory blocks. The BATC translations are used for operating system software or for other memory-resident instructions and data. In addition, the MMU provides access control for the two logical address spaces. The CMMU data cache is a 16-kilobyte, four-way, set-associative cache for instruction or data storage. The cache incorporates memory-update policies and cache-coherency mechanisms that support multiprocessor applications. The MC88200 CMMU also includes an MC88100-compatible P bus (processor bus) interface and an M bus (memory bus) interface. A processor may use two or more CMMUs for increased data cache and ATC sizes.

## MC88204RC

### 64K-Byte Cache/Memory Management Unit (CMMU)

The MC88204 CMMU is a high-performance, HCMOS VLSI device providing zero-wait-state memory management and data caching. The memory management unit (MMU) efficiently supports a demand-paged virtual memory environment with two logical address ranges (user/supervisor) of 4 Gbytes each. Translated addresses are provided by one of two address translation caches (ATCs), providing address translation in one clock cycle for most memory accesses. The page address translation cache (PATC) is a 56-entry, fully associative cache containing recently used translations for 4K-byte memory pages and is

maintained by MC88204 hardware. The block address translation cache (BATC) is a 10-entry cache, loaded by software, containing translations for 512K-byte memory blocks. The BATC translations are used for operating system software or for other memory-resident instructions and data. In addition, the MMU provides access control for the two logical address spaces. The CMMU data cache is a 64K-byte, four-way set-associative cache for instruction or data storage. The cache incorporates memory-update policies and cache-coherency mechanisms that support multiprocessor applications. The MC88204 CMMU also includes an MC88100-compatible processor bus (P bus) interface and memory bus (M bus) interface.

The MC88204 CMMU is completely software and pin-level compatible with the MC88200 16K-byte CMMU. The functionality of the MC88204 is identical to that of the MC88200. With board layout constraints in mind, a central processing unit (CPU) may use up to two MC88204 CMMUs on the data P bus and up to two MC88204 CMMUs on the instruction P bus to increase data cache and ATC sizes.

2

## MC88410

### Secondary Cache Controller

The MC88410 is a highly integrated secondary cache controller for the MC88110 microprocessor that reduces memory latency and extends multiprocessing capability for those seeking the highest level of system performance. Used with the MCM62110 Fast Static RAM, it provides a functionally complete secondary cache solution for both uniprocessor and multiprocessor environments. The MC88410 provides tag, control and buffering for 1/4, 1/2, and 1 Mbyte secondary cache configurations, all in a single chip cache controller. The MC88410 eliminates external logic between the processor and the secondary cache, provides bus arbitration for the MC88110, and requires no external programming.

The MC88410 and MCM62110 are optimized to provide low latency memory access to the MC88110 processor. Initial accesses incur only one wait state. Subsequent transactions in a burst incur zero wait states. Data streaming to the processor reduces the penalty on secondary cache misses.

The MC88410 expands the MC88110's system flexibility by providing a choice of secondary cache line size, burst byte ordering, and system clock frequency. The MC88410 extends the MC88110 multiprocessing capability by significantly reducing system bandwidth consumption. This increased available bandwidth, along with the MC88410's hardware enforced cache coherency protocol, enable the implementation of dual bus systems and scalable shared-bus multiprocessing systems.



**2**

# The PowerPC™ RISC Family Microprocessors

---

### In Brief . . .

The PowerPC architecture is derived from the IBM Performance Optimized with Enhanced RISC (POWER) architecture. The PowerPC architecture shares all of the benefits of the POWER architecture but is optimized for single-chip implementations. The architecture design emphasizes parallel instruction execution and high throughput and allows for exceptional floating-point performance. The PowerPC architecture is powerful today and is scalable from palmtops to mainframes. The MPC601 is a 32-bit implementation of the 64-bit PowerPC architecture.

	<b>Page</b>
MPC601 RISC Microprocessor . . . . .	2.4-2
MPC603 RISC Microprocessor . . . . .	2.4-4

# MPC601 RISC Microprocessor

The MPC601 is the first implementation of the PowerPC family of Reduced Instruction Set Computer (RISC) microprocessors. The MPC601 implements the 32-bit portion of the PowerPC architecture, which provides 32-bit effective (logical) addresses, integer data types of 8, 16, and 32 bits, and floating-point data types of 32 and 64 bits. For 64-bit PowerPC implementations, the PowerPC architecture provides 64-bit integer data types, 64-bit addressing, and other features required to complete the 64-bit architecture.

The MPC601 is a superscalar processor capable of issuing and retiring three instructions per clock, one to each of three execution units. Instructions can complete out of order for increased performance; however, the MPC601 makes execution appear sequential.

The MPC601 integrates three execution units — an integer unit (IU), a branch processing unit (BPU), and a floating-point unit (FPU). The ability to execute three instructions in parallel and the use of simple instructions with rapid execution times yield high efficiency and throughput for MPC601-based systems. Most integer instructions execute in one clock cycle. The FPU is pipelined so a single-precision multiply-add instruction can be issued every clock cycle.

The MPC601 includes an on-chip, 32-Kbyte, eight-way set-associative, physically addressed, unified instruction and data cache and an on-chip memory management unit (MMU). The MMU contains a 256-entry, two-way set-associative, unified translation look-aside buffer (UTLB) and provides support for demand paged virtual memory address translation and variable-sized block translation. Both the UTLB and the cache use least recently used (LRU) replacement algorithms.

The MPC601 has a 64-bit data bus and a 32-bit address bus. The MPC601 interface protocol allows multiple masters to compete for system resources through a central external arbiter. Additionally, on-chip snooping logic maintains cache coherency in multiprocessor applications. The MPC601 supports single-beat and burst data transfers for memory accesses; it also supports both memory-mapped I/O and I/O controller interface addressing.

The MPC601 uses an advanced, 3.6-V CMOS process technology and maintains full interface compatibility with TTL devices.

## MPC601 Features

Major features of the MPC601 are as follows:

- High-performance, superscalar microprocessor
  - As many as three instructions in execution per clock (one to each of the three execution units)
  - Single clock cycle execution for most instructions
  - Pipelined FPU for all single-precision and most double-precision operations
- Three independent execution units and two register files
  - BPU featuring static branch prediction
  - A 32-bit IU

- Fully IEEE 754-compliant FPU for both single- and double-precision operations
- Thirty-two GPRs for integer operands
- Thirty-two FPRs for single- or double-precision operands
- High instruction and data throughput
  - Zero-cycle branch capability
  - Programmable static branch prediction on unresolved conditional branches
  - Instruction unit capable of fetching eight instructions per clock from the cache
  - An eight-entry instruction queue that provides look-ahead capability
  - Interlocked pipelines with feed-forwarding that control data dependencies in hardware
  - Unified 32-Kbyte cache — eight-way set-associative, physically addressed; LRU replacement algorithm
  - Cache write-back or write-through operation programmable on a per page or per block basis
  - Memory unit with a two-element read queue and a three-element write queue
  - Run-time reordering of loads and stores
  - BPU that performs condition register (CR) look-ahead operations
  - Address translation facilities for 4-Kbyte page size, variable block size, and 256-Mbyte segment size
  - A 256-entry, two-way set-associative UTLB
  - Four-entry BAT array providing 128-Kbyte to 8-Mbyte blocks
  - Four-entry, first-level ITLB
  - Hardware table search (caused by UTLB misses) through hashed page tables
  - 52-bit virtual address; 32-bit physical address
- Facilities for enhanced system performance
  - Bus speed defined as selectable division of operating frequency
  - A 64-bit split-transaction external data bus with burst transfers
  - Support for address pipelining and limited out-of-order bus transactions
  - Snooped copyback queues for cache block (sector) copyback operations
  - Bus extensions for I/O controller interface operations
  - Multiprocessing support features that include the following:
    - Hardware enforced, four-state cache coherency protocol (MESI)
    - Separate port into cache tags for bus snooping
- In-system testability and debugging features through boundary-scan capability

### Block Diagram

Figure 1 provides a block diagram of the MPC601 that illustrates how the execution units — IU, FPU, and BPU — operate independently and in parallel.

2

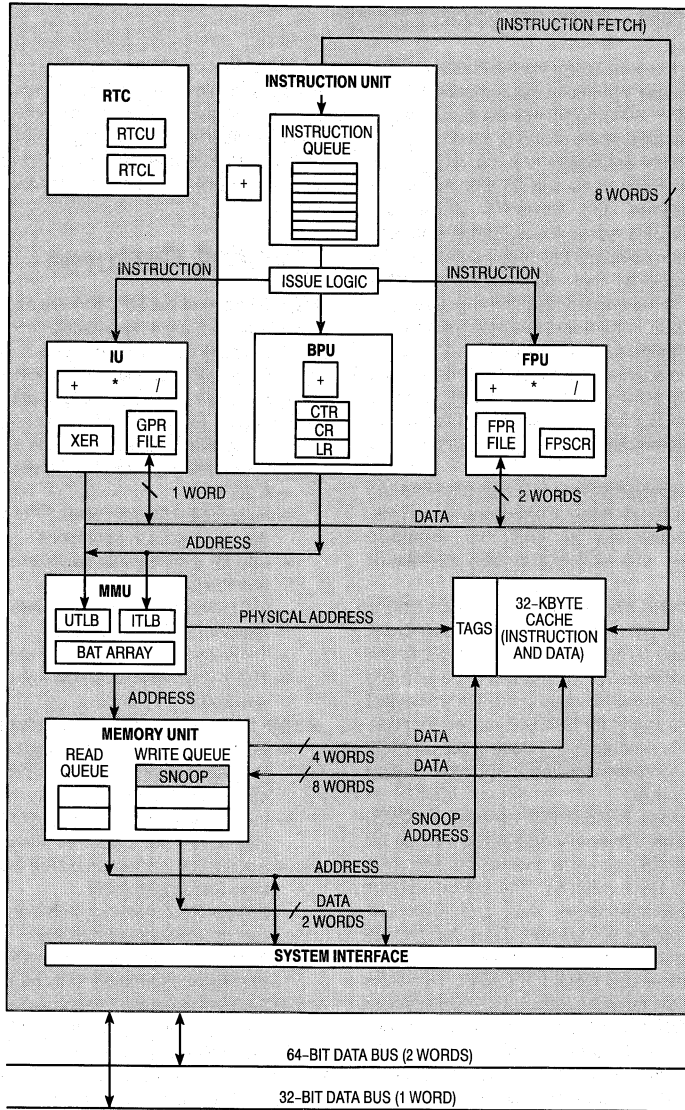

Figure 1. MPC601 Block Diagram

# MPC603 RISC Microprocessor

The MPC603 is the first low-power implementation of the PowerPC family of reduced instruction set computer (RISC) microprocessors. The MPC603 implements the 32-bit portion of the PowerPC architecture, which provides 32-bit effective (logical) addresses, integer data types of 8, 16, and 32 bits, and floating-point data types of 32 and 64 bits. For 64-bit PowerPC implementations, the PowerPC architecture provides 64-bit integer data types, 64-bit addressing, and other features required to complete the 64-bit architecture.

The MPC603 provides four software controllable power-saving modes. Three of the modes (the nap, doze, and sleep modes) are static in nature, and progressively reduce the amount of power dissipated by the processor. The fourth is a dynamic power management mode that causes the functional units in the MPC603 to automatically enter a low-power mode when the functional units are idle without affecting operational performance, software execution or any external hardware.

The MPC603 is a superscalar processor capable of issuing and retiring a maximum of three instructions per clock. Instructions can execute out of order for increased performance; however, the MPC603 makes completion appear sequential.

The MPC603 integrates five execution units — an integer unit (IU), a floating-point unit (FPU), a branch processing unit (BPU), a load/store unit (LSU) and a system register unit (SRU). The ability to execute five instructions in parallel and the use of simple instructions with rapid execution times yield high efficiency and throughput for MPC603-based systems. Most integer instructions execute in one clock cycle. The FPU is pipelined so a single-precision multiply-add instruction can be issued every clock cycle.

The MPC603 provides independent on-chip, 8-Kbyte, two-way set-associative, physically addressed caches for instructions and data and on-chip instruction and data memory management units (MMUs). The MMUs contain 64-entry, two-way set-associative, data and instruction translation lookaside buffers (DTLB and ITLB) that provide support for demand-paged virtual memory address translation and variable-sized block translation. The TLBs and caches use a least recently used (LRU) replacement algorithm. The MPC603 also supports block address translation through the use of two independent instruction and data block address translation (BAT) arrays of four entries each. Effective addresses are compared simultaneously with all four entries in the BAT array during block translation. In accordance with the PowerPC architecture, if an effective address hits in both the TLB and BAT array, the BAT translation takes priority.

The MPC603 has a selectable 32- or 64-bit data bus and a 32-bit address bus. The MPC603 interface protocol allows multiple masters to compete for system resources through a central external arbiter. The MPC603 provides a three-state coherency protocol that supports the Exclusive, Modified, and Invalid cache states. This protocol is a compatible subset of the MESI four-state protocol and operates coherently in

systems that contain four-state caches. The MPC603 supports single-beat and burst data transfers for memory accesses; it also supports both memory-mapped I/O and I/O controller interface addressing.

The MPC603 uses an advanced, 3.3-V CMOS process technology and maintains full interface compatibility with TTL devices.

## MPC603 Features

Major features of the MPC603 are as follows:

- High-performance, superscalar microprocessor
  - As many as five instructions in execution per clock
  - Single cycle execution for most instructions
  - Pipelined FPU for all single-precision and most double-precision operations
- Five independent execution units and two register files
  - BPU featuring static branch prediction
  - A 32-bit IU
  - Fully IEEE 754-compliant FPU for both single- and double-precision operations
  - LSU for data transfer between data cache and GPRs and FPRs
  - SRU executes condition register and special purpose register (SPR) instructions
  - Thirty-two GPRs for integer operands
  - Thirty-two FPRs for single- or double-precision operands
- High instruction and data throughput
  - Zero-cycle branch capability (branch folding)
  - Programmable static branch prediction on unresolved conditional branches
  - Instruction fetch unit capable of fetching two instructions per clock from the instruction cache
  - A six-entry instruction queue that provides look-ahead capability
  - Independent pipelines with feed-forwarding that reduces data dependencies in hardware
  - 8-Kbyte data cache — two-way set-associative, physically addressed; LRU replacement algorithm
  - 8-Kbyte instruction cache — two-way set-associative, physically addressed; LRU replacement algorithm
  - Cache write-back or write-through operation programmable on a per page or per block basis
  - BPU that performs condition register (CR) look-ahead operations
  - Address translation facilities for 4-Kbyte page size, variable block size, and 256-Mbyte segment size
  - A 64-entry, two-way set-associative ITLB
  - A 64-entry, two-way set-associative DTLB
  - Four-entry data and instruction BAT arrays providing 128-Kbyte to 256-Mbyte blocks
  - Software table search operations and updates supported through fast trap mechanism
  - 52-bit virtual address; 32-bit physical address

2

- Facilities for enhanced system performance
  - A 32- or 64-bit split-transaction external data bus with burst transfers
  - Support for one level address pipelining and out-of-order bus transactions
  - Bus extensions for I/O controller interface operations
- Integrated power management
  - Low-power 3.3 volt design
  - Internal processor/bus clock multiplier provides 1/1, 2/1, 3/1 and 4/1 ratios
  - Three power saving modes: doze, nap, and sleep
  - Automatic dynamic power reduction when internal functional units are idle

- In-system testability and debugging features through JTAG boundary-scan capability

#### **MPC603 Block Diagram**

Figure 2 provides a block diagram of the MPC603 that illustrates how the execution units — IU, FPU, BPU, LSU, and SRU — operate independently and in parallel.

The MPC603 provides address translation and protection facilities, including an ITLB, DTLB, and instruction and data BAT arrays. Instruction fetching and issuing is handled in the instruction unit. Translation of addresses for cache or external memory accesses are handled by the MMUs.

**2**

2

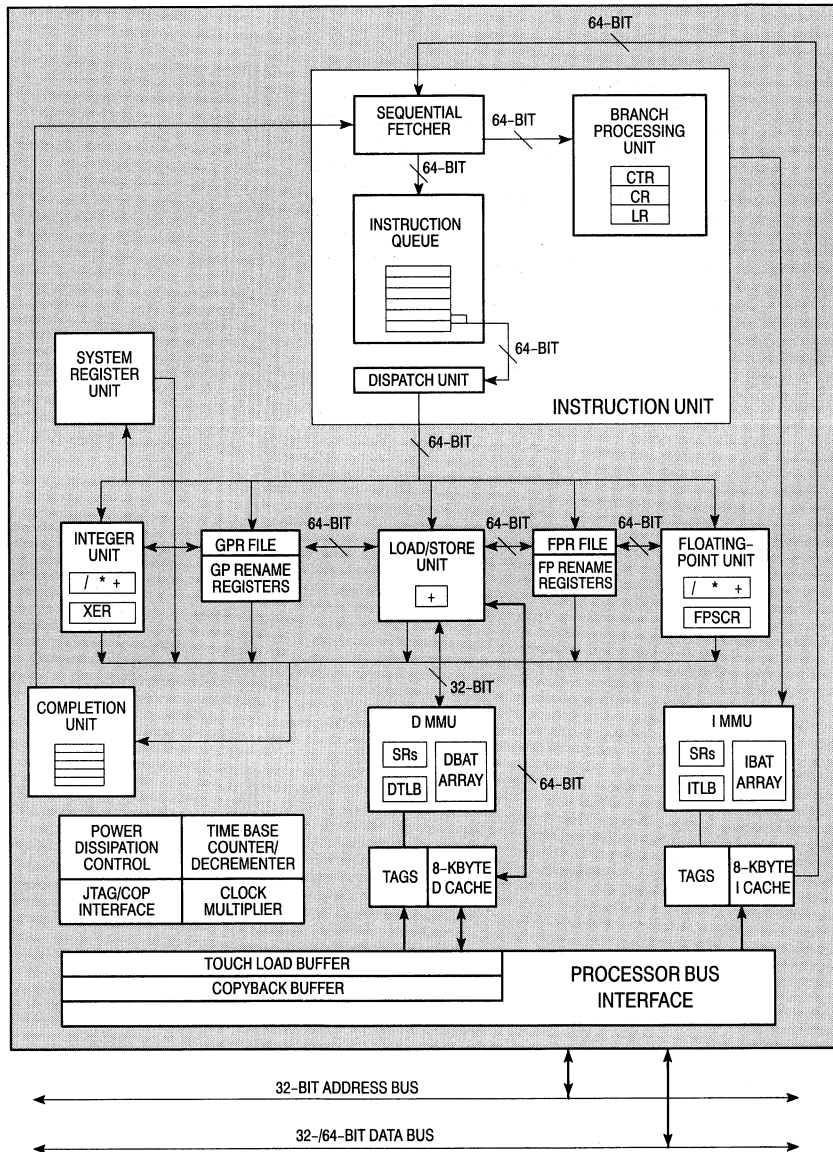

Figure 2. MPC603 Block Diagram

# Single-Chip Microcontrollers (MCU)

---

## In Brief . . .

Motorola offers the most comprehensive selection of high-performance single-chip control systems available from a single source. Microcontroller device families range from industry-standard 8-bit controllers to state-of-the-art 16- and 32-bit modular controllers. Within the price and performance categories of each family, there are a variety of on-chip capabilities to match specific applications.

Motorola device families are structured so that upward migration need not involve complete code development. The M68HC11 Family is upward code compatible with M6800 and M6801 software, while the M68HC16 family is source-code compatible with the M68HC11 family. Motorola's newest 8-bit MCU product line, the M68HC08 family, is fully upward object code compatible with the M68HC05 and M6805 families. In addition, M68300 and M68HC16 devices share standard internal modules and bus configurations.

	<b>Page</b>
M68HC05 CSIC Family .....	2.5-2
M68HC08 Family .....	2.5-18
M68HC11 Family .....	2.5-19
Modular Microcontroller .....	2.5-29
The M68HC16 Family .....	2.5-31
The M68300 Family .....	2.5-36
Development Tools .....	2.5-39
Fuzzy Logic .....	2.5-43
On-Line Help .....	2.5-43
Third-Party Support .....	2.5-44



# M68HC05 CSIC Family

There are now more than 150 different standard products in the M68HC05 family. This family of products offers more on-chip memory and peripheral options than any other microcontroller line.

The M68HC05 Family is the basis for the Motorola Customer Specified Integrated Circuit (CSIC) design program. The CSIC program is targeted for high-volume projects that require the cost-efficiency of standard devices, but have requirements that cannot be met by "off the shelf" components.

To develop a CSIC, the user selects the 68HC05 microcontroller that best meets design specifications, then specifies additional features, such as on-chip memory (including RAM, ROM, EPROM, and EEPROM), communications interfaces (such as SCI, SPI, SIOP and I<sup>2</sup>C), timers, A/D converters, pulse-width modulators, or display drivers. Motorola design engineers evaluate customer requests to create a device that best meets the needs of the market. The resulting CSIC often becomes a standard product in the M68HC05 Family.

Motorola has an extensive line of one-time programmable (OTP) microcontrollers that can be used to prototype new products. Code changes can be made quickly in OTP devices, and OTP microcontrollers cost much less than windowed EPROM devices. OTP devices can also be used for low-to-medium quantity production runs, or for products that require different code for model variation.

## M68HC05 General Purpose Microcontrollers

M68HC05 C-Series devices offer a wide variety of memory options capable of handling complex programs. An on-chip SCI provides asynchronous communications with software-selectable baud rates from 75 Hz to 131 kHz. The SPI, a high-speed, synchronous 4-wire serial system, is ideal for driving off-chip displays and peripherals. C-Series devices include a powerful 16-bit free running programmable counter in conjunction with input capture and output compare functions for simultaneous input waveform measurement and output waveform generation. A watchdog timer is available to guard against software runaway in noisy environments.

The M68HC05 E Series includes the 68HC05E0, the first expandable M68HC05 without on-chip ROM. Designed as an expanded part, the 68HC05E0 can address up to 64K bytes of external memory and is available off the shelf without mask production.

The G Series was created to support the demands of portable computer applications. With features like dual SCI, keyboard control, PLL, and power management, the G-Series provides an extremely versatile control solution for the next generation of laptop computers.

The H Series is a LDMOS (Lateral Diffusion Metal-Oxide Silicon) device. LDMOS is capable of driving high current and high voltage without external components, making it ideal for portable applications using brushless motors.

To address the special requirements of CD-I (Compact Disk-Interactive) applications, the I Series features an on-chip

68000 interface module and dual SCI for multiple peripheral control.

The J Series has developed an affordable 20-lead tier of the 8-bit M68HC05 Family. The powerful 68HC05 CPU is combined with a flexible, 15-stage multifunction timer and real-time interrupt capability.

The K Series is our lowest-cost, lowest-pin count microcontroller series to date. The K Series includes the first 68HC05 microcontrollers to be offered in compact 16-lead DIP and SOIC packages, and it provides the optimum solution for cost-sensitive applications requiring 8-bit performance at 4-bit prices.

Born out of the CSIC design concept, the P Series offers a 28-lead family of microcontrollers with a variety of ROM sizes and special features such as a Serial Input/Output Port (SIOP) to control display drivers and communicate with other peripherals. Other options include A/D input and on-chip EEPROM for non-volatile data storage.

## M68HC05 Telephone Microcontrollers

The F Series is designed for a broad range of telecommunications applications, particularly cordless and cellular phones. Options include an on-chip Dual-Tone Multi-Frequency (DTMF) generator and receiver, LED drive, tone generator, and keyboard interrupts.

## M68HC05 Analog I/O + EEPROM Microcontrollers

The M68HC05 B-Series features on-chip EEPROM, an 8-channel 8-bit A/D converter, and pulse-width modulation (PWM) outputs making it ideal for a wide range of automotive, industrial, and consumer applications. Non-volatile EEPROM can retain user-programmed settings or factory codes. The A/D system can convert information provided from optical, temperature, and pressure sensors into digital signals for processing. Software stored in EEPROM can also be used to monitor and calibrate sensors, greatly reducing overall system cost. PWM outputs can then be used for precise motor control, minimizing additional circuitry, or to generate analog signals.

## M68HC05 Display Microcontrollers

The L-Series is a versatile selection of very powerful microcontrollers capable of driving the large liquid crystal display (LCD) modules utilized in today's advanced handheld equipment. The series is designed specifically for low-power applications where minimum chip count is essential. On-chip options include a tone generator for alert functions found in pagers, telephones, and dashboard displays; full expanded bus with a Memory Management Unit (MMU) for efficient external data handling; real-time clock; and key-pressed wake-up from sleep mode. The L-Series is ideal for multi-language translator and pocket directory applications.

2

## M68HC05 Display Microcontrollers (continued)

The T Series offers a features suited for many video and television applications. The On-Screen Display (OSD) system provides a multi-color display capability for menu-driven features. The A/D converter can be used to control fine tuning, while PWM converter systems can control volume, brightness, and other analog functions.

The CC-series of TV microcontrollers evolved from the T-family. In addition to TV control peripherals, these devices have closed-caption Data Slicer (DSL) and enhanced OSD features for the decoding and display of closed captions.

The D Series offers additional D/A output capability combined with a high-current LED drive for a variety of applications with display requirements.

The M Series is designed specifically for appliance and audio/visual applications utilizing vacuum fluorescent display (VFD). The on-chip VFD driver provides 40-volts on 24 bidirectional I/O lines. An additional 8-bit free-running

modulus timer makes the M series suited to applications with complex timing requirements. Other features include a 6-channel 8-bit A/D system, SCI, and a large ROM option.

## M68HC05 Smart Card Microcontrollers

Motorola is the leading designer and manufacturer of secure microcontrollers for smart card and conditional access systems. With over 10 years experience in smart card applications, Motorola has extensive knowledge of the technical requirements and can offer full hardware and software support. The SC Series is designed specifically for use in smart card applications, and has some of the smallest available microcontroller die sizes.

2

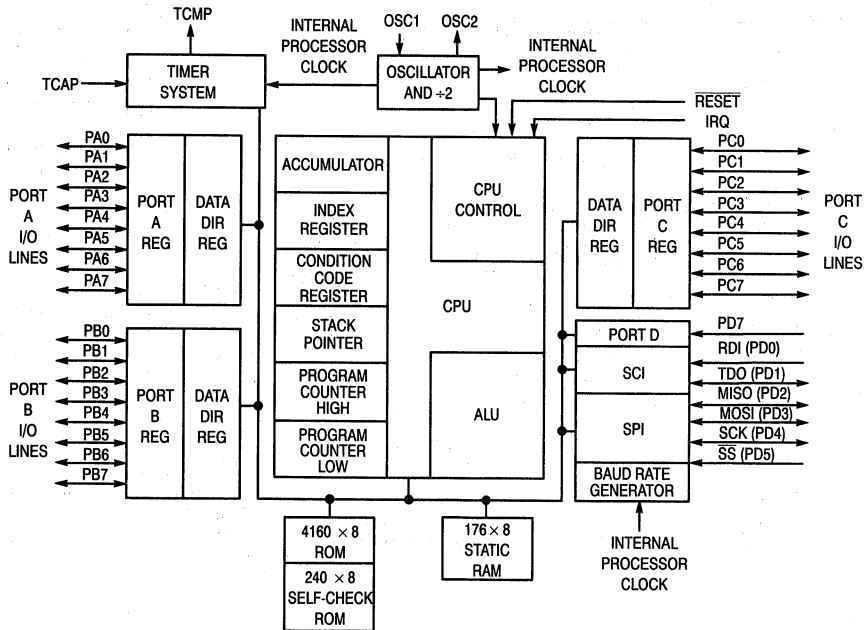

Figure 1. MC68HC05C4 Block Diagram

2

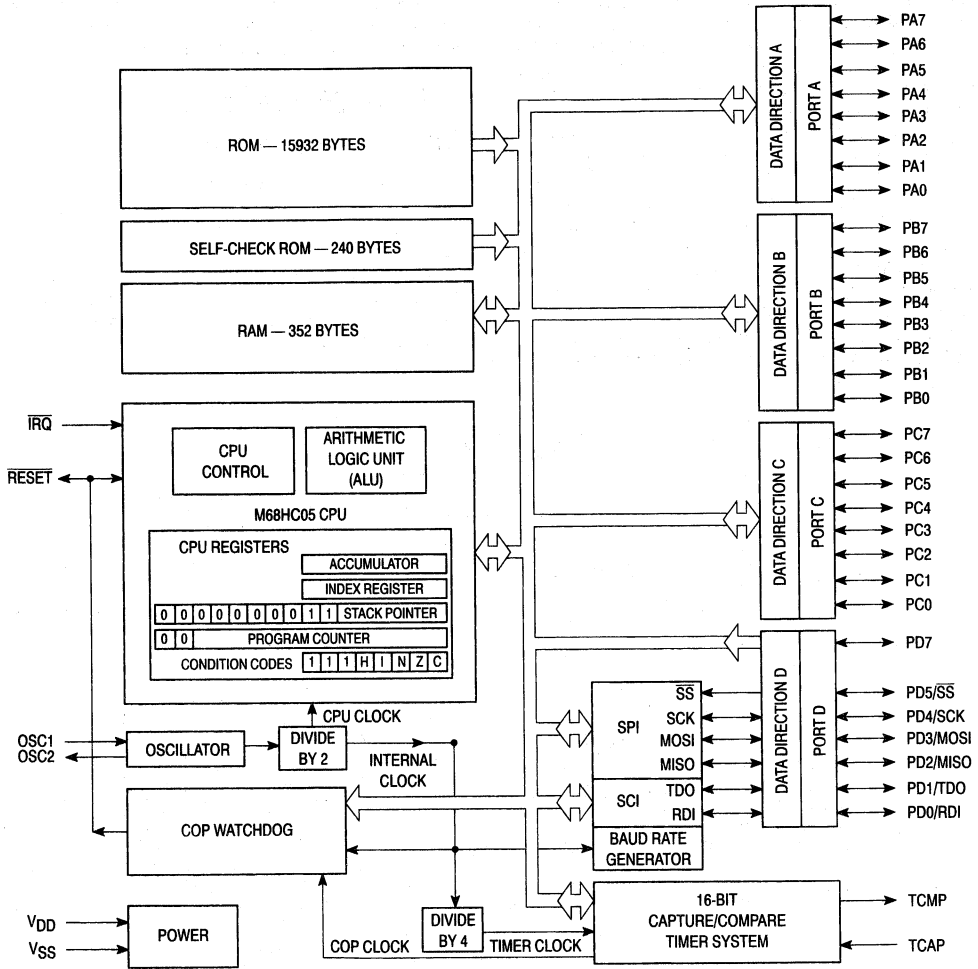

Figure 2. MC68HC05C9 Block Diagram

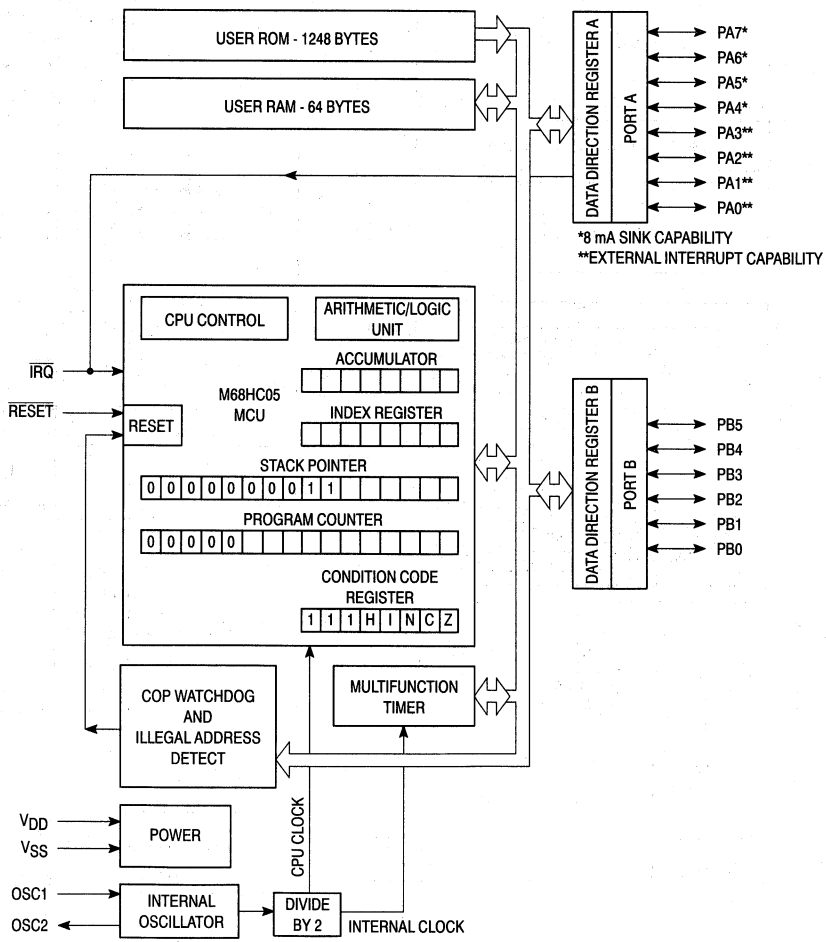

Figure 3. MC68HC05J1A Block Diagram

2

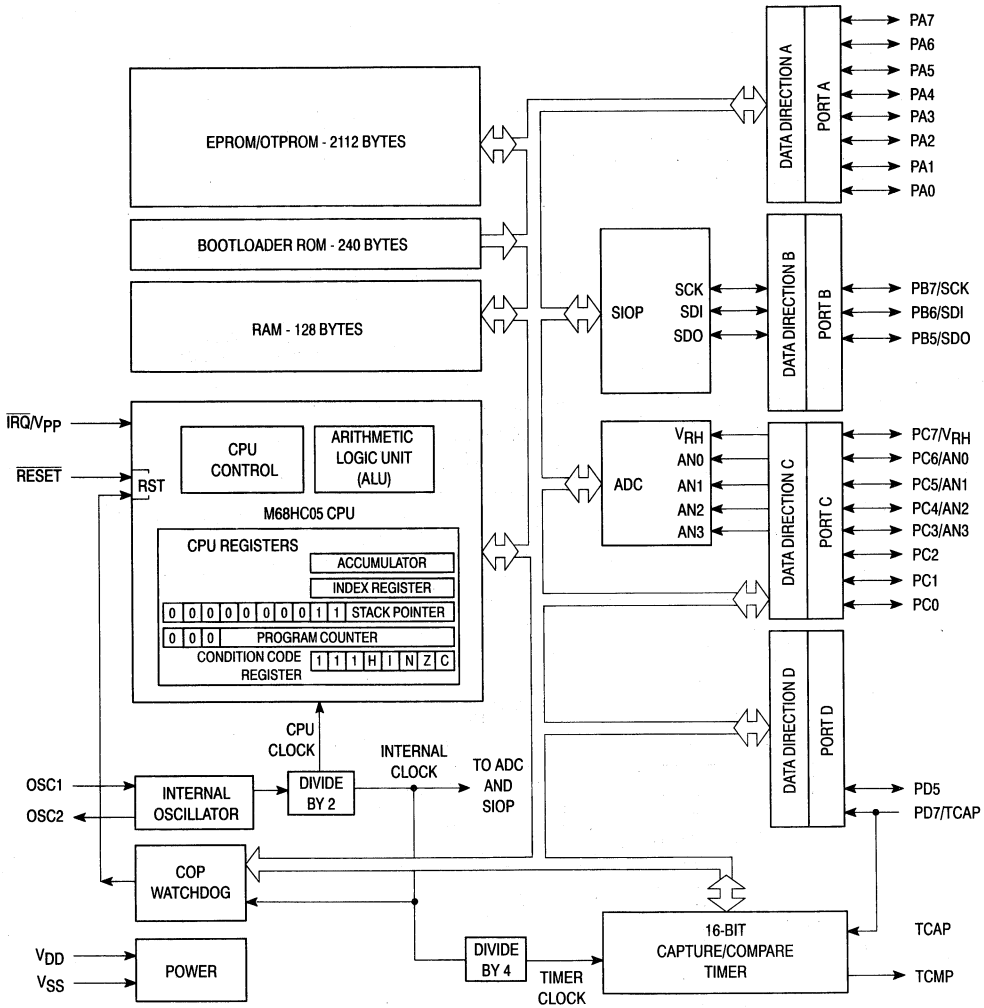

Figure 4. MC68HC705P9 Block Diagram

## 68HC05 MICROCONTROLLERS

All 68HC05 products have a standard operating voltage range from 3 V to 5.5 V unless noted in Comments.  
All 68HC05 products have a standard operating temperature range from 0-70°C. Contact a Motorola Sales Office for availability of extended temperature versions.

**Table 1. 68HC05 General-Purpose Microcontrollers**

Part Number	ROM (Bytes)	RAM (Bytes)	EEPROM Bytes	Timer	Serial	A/D	PWM	Display Drive	I/O	COP	Comments	Package
MC68HC05B4	4K	176		16-bit: (2IC, 2OC)	SCI	8 ch (8-bit)	2 ch (8-bit)		24 i/o 8 i 2 o	✓		56 SDIP-B 52 PL-CCFN
MC68HC05B6	6K	176	256	16-bit: (2IC, 2OC)	SCI	8 ch (8-bit)	2 ch (8-bit)		24 i/o 8 i 2 o	✓	On-Chip Charge Pump EEPROM Write Protect	56 SDIP-B 52 PLCC-FN 64 QFP-FU
MC68HC05B8	7.25K	176	256	16-bit: (2IC, 2OC)	SCI	8 ch (8-bit)	2 ch (8-bit)		24 i/o 8 i 2 o	✓	On-Chip Charge Pump EEPROM Write Protect	56 SDIP-B 52 PLCC-FN
XC68HC05B16	15K	352	256	16-bit: (2IC, 2OC)	SCI	8 ch (8-bit)	2 ch (8-bit)		24 i/o 8 i 2 o	✓	On-Chip Charge Pump KBI (8 pins) EEPROM Write Protect	52 PLCC-FN 64 QFP-FU
MC68HC05C4	4K	176		16-bit: (1IC, 1OC)	SCI SPI				28 i/o 3 i		High Speed Option (HSC05C4) Low Power Option (HCL05C4)	40 DIP-P 44 PLCC-FN 44 QFP-FB 42 SDIP-B
MC68HC05C5	5K	176	128	16-bit: (1IC, 1OC)	SIOP				32 i/o	✓	8 High Current Pins (10 mA sink) LVPI, On-Chip Charge Pump	40 DIP-P 44 PLCC-FN
MC68HC05C8	8K	176		16-bit: (1IC, 1OC)	SCI SPI				28 i/o 3 i		High Speed Option (HSC05C8) Low Power Option (HCL05C8)	40 DIP-P 44 PLCC-FN 44 QFP-FB 42 SDIP-B
MC68HC05C9	16K	352		16-bit: (1IC, 1OC)	SCI SPI				31 i/o	✓	705C9 not available in QFP	40 DIP-P 44 PLCC-FN 44 QFP-FB 42 SDIP-B
XC68HC05C9A	16K	352		16-bit: (1IC, 1OC)	SCI SPI				31 i/o 1 i	✓	1 High Current Pin (20 mA sink) Mask Option Pullups (8 pins) KBI (8 pins)	40 DIP-P 44 PLCC-FN 44 QFP-FB 42 SDIP-B
MC68HC05C12	12K	176		16-bit: (1IC, 1OC)	SCI SPI				28 i/o 3 i	✓	1 High Current Pin (20 mA sink) KBI (8 pins) Mask Option Pullups (8 pins)	40 DIP-P 44 PLCC-FN 44 QFP-FB 42 SDIP-B
XC68HC05CC1	16K	544		8-bit: Pulse Accum MFT	I <sup>2</sup> C	1 ch (5-bit)	8 ch (6-bit)	OSD (127 Char ROM)	31 i/o		Closed Caption Television NTSC Data Slicer w/int Sync Sep 28 MHz PLL 8 Open Drain I/O Pins, 5 V Only	40 DIP-P 42 SDIP-B
MC68HC05D9	16K	352		16-bit: (1IC, 1OC)	SCI		5 ch (6-bit)		32 i/o	✓	8 High Current Pins (25 mA sink) 30 kHz PWM	40 DIP-P 44 PLCC-FN

2

**Table 1. 68HC05 General-Purpose Microcontrollers (continued)**

Part Number	ROM (Bytes)	RAM (Bytes)	EEPROM Bytes	Timer	Serial	A/D	PWM	Display Drive	I/O	COP	Comments	Package
MC68HC05D24	24K	352		16-bit: (1IC, 1OC)	SCI		5 ch (6-bit)		31 i/o	✓	8 High Current Pins (24 mA sink) 30 kHz PWM	40 DIP-P 44 PLCC-FN 44 QFP-FB
XC68HC05D32	32K	352		16-bit: (1IC, 1OC)	SCI		5 ch (6-bit)		31 i/o	✓	8 High Current Pins (24 mA sink) 30 kHz PWM	40 DIP-P 44 PLCC-FN
MC68HC05E0	0	480		MFT, RTI	SPI I <sup>2</sup> C				36 i/o		Non-Mux EBI 8 (16-bit Address) w/3 Chip Selects High Current Pins (24 mA sink) KBI (8 pins), 5 V Only	68 PLCC-FN
MC68HC05E1	4K	368		MFT, RTI					20 i/o	✓	32 kHz PLL Clock Synthesizer	28 DIP-P 28 SOIC-DW
XC68HC05F2	2K	256		16-bit: (1IC, 1OC)	SPI				30 i/o 2 o		DTMF Generator 4 High Current Pins (10 mA sink) KBI (6 pins)	42 SDIP-B 44 QFP-FB
MC68HC05F5	5K	224		MFT, RTI					30 i/o 1 i	✓	DTMF Receiver Mask IRQ	40 DIP-P 44 PLCC-FN
MC68HC05F6	4K	320		16-bit: (1IC, 1OC)	SPI				26 i/o 4 i 2 o		DTMF Generator 8 High Current Pins (10 mA sink) KBI (6 pins)	42 SDIP-B 44 QFP-FB 64 QFP-FU
XC68HC05F8	8K	320		16-bit (1IC, 1OC) 16-bit: auto	SPI				50 i/o 2 o	✓	DTMF Generator KBI (8 pins) Manchester Encoder/ Decoder 8 High Current Pins (10 mA sink)	64 QFP-FU
MC68HC05G1	8K	176		16-bit: (1IC, 1OC) RTC	SPI	4 ch (8-bit)			40 i/o 8 i	✓	32 kHz PLL-Standby modes	56 SDIP-B 64 QFP-FU
MC68HC05G3	24K	768		16-bit: (1IC, 1OC) 8-bit: Event Cntr	Dual SPI	8 ch (8-bit)	4 ch (8-bit)		48 i/o 16 i 4 o	✓	KBI (8 pins) Dual Oscillators-Selectable Clock Dual IRQ	80 QFP-FU
XC68HC05G9	12K	304		MFT, RTC	PIO 2 SIO	8 ch (8-bit)	4 ch (8-bit)		40 i/o 24 i		KBI (8 pins), Keyboard Controller IDE Interface, Power Management 32 kHz PLL, Host Address Decoder 4 Programmable Chip Selects	160 QFP-FT

**2**

**Table 1. 68HC05 General-Purpose Microcontrollers (continued)**

Part Number	ROM (Bytes)	RAM (Bytes)	EEPROM Bytes	Timer	Serial	A/D	PWM	Display Drive	I/O	COP	Comments	Package
XC68HC05G10	12K	304		MFT, RTC		5 ch (8-bit)	4 ch (8-bit)		39 i/o 23 i		100 Pin Version of G9, Power Mgmt KBI (8 pins), Keyboard Controller 4 Programmable Chip Selects 32 kHz PLL, Host Address Decoder	100 QFP-FU
XC68HC05H2	2K	128		MFT, RTI	SIOP		2 ch (8-bit)		16 i/o 4 i 4 o	✓	4 LDMOS Power Output Drivers w/Switch, Driver, and H-Bridge 4 Voltage Compare Channels	40 DIP-P 42 SDIP-B 44 QFP-FB
XC68HC05I8	8K	224		16-bit: (2IC, 1OC) RTI	Dual SCI				42 i/o	✓	68000 Interface Module Receiver Wake-up	64 QFP-FU 68 PLCC-FN
MC68HC05J1	1K	64		MFT, RTI					14 i/o	✓		20 DIP-P 20 SOIC-DW
MC68HC05J1A	1K	64		MFT, RTI					14 i/o	✓	KBI (4 pins) 4 High Current Pins (8 mA sink) Mask Option Pulldowns (14 pins)	20 DIP-P 20 SOIC-DW
XC68HC05J3	2K	128		16-bit: (1IC, 1OC) MFT, RTI					14 i/o	✓	14 High Current Pins (8 mA sink) KBI (4 pins)	20 DIP-P 20 SOIC-DW
XC68HC05K0	0.5K	32		MFT, RTI					10 i/o	✓	4 High Current Pins (8 mA sink) Programmable Pulldowns (10 pins)	16 DIP-P 16 SOIC-DW
XC68HC05K1	0.5K	32		MFT, RTI					10 i/o	✓	4 High Current Pins (8 mA sink) PEP (64 bits) Programmable Pulldowns (10 pins)	16 DIP-P 16 SOIC-DW
XC68HC05L1	4K	128		16-bit: (2IC, 2OC)		6 ch (8-bit)		64 Segment LCD (3/4 x 12/16)	17 i/o 15 i 2 o			56 SDIP-B 64 QFP-FU
XC68HC05L2	2K	96		16-bit: (1IC, 1OC) MFT, RTI	I <sup>2</sup> C	1 ch (8-bit)		45 Segment LCD: (3 x 15)	13 i/o	✓	Programmable Pullups (13 pins)	42 SDIP-B

2



**Table 1. 68HC05 General-Purpose Microcontrollers (continued)**

Part Number	ROM (Bytes)	RAM (Bytes)	EEPROM Bytes	Timer	Serial	A/D	PWM	Display Drive	I/O	COP	Comments	Package
XC68HC05L4	8K	224		2 x 16-bit: (1IC, 1OC) MFT, RTI				96 Segment LCD: (2/3/4 x 24)	24 i/o 8 i	✓	KBI (8 pins) Programmable Pullups (8 pins)	64 QFP-FU
MC68HC05L5	8K	256		16-bit: (1IC, 1OC) RTI 8-bit: (1IC, 1OC)	SIOP			156 Segment LCD: (1-4 x 27-39)	14 i/o 10 i 15 o		KBI (8 pins), Dual Oscillators 8 High Current Pins (10 mA sink) Programmable Pullups (24 pins) Open Drain (31 pins), 2.2 V	80 QFP-FU
XC68HC05L6	6K	176		16-bit: (1IC, 1OC)	SPI			96 Segment LCD: (3/4 x 24)	24 i/o		Tone Generator	68 PLCC-FN
MC68HC05L7	6K	176		16-bit: (1IC, 1OC) RTC	SCI			960 Segment LCD: (8/16 x 60)	15 i/o		Mux EBI (13-bit Address), 32 kHz PLL, KBI (8 pins), LVI Tone Generator	128 QFP-FT Die
MC68HC05L9	6K	176		16-bit: (1IC, 1OC) RTC	SCI			640 Segment LCD: (8/16 x 40)	27 i/o 2 i		Mux EBI (16-bit Address 32 kHz PII, KBI (8 pins), LVI Expand LCD to 3K Segments w/68HC68L9, Tone Generator	128 QFP-FT Die
MC68HC05L10	13K	352		16-bit: (1IC, 1OC) RTC	SPII SCI			5K-20K Pixel LCD: (2 to 4 chip set)	28 i/o		Mux EBI w/MMU 20 bit Address) 4 Chip Selects, KBI (8 pins) Tone Generator/ DTMF, 32 kHz PLL, LCD Expansion 2/MC141511	128 QFP-FT Die
XC68HC05L11	3K	448		16-bit: (1IC, 1OC) RTC	SPII SCI			Up to 40 K Pixel LCD (3 Chip set)	38 i/o		Mux EBI w/MMU (23-bit Address) 4 Chip Selects, KBI (8 pins) Tone Generator/ DTMF, 32 kHz PLL	100 QFP-FU
MC68HC05L12	8K	256		16-bit: (1IC, 1OC) RTI	SSPI			128 Segment LCD: (3 x 33 or 4 x 32)	15 i/o 8 i 1 o	✓	KBI (8 pins), Remote Control, Dual Oscillators, Buzzer Output, Programmable Pullups (16 pins) Open Drain (20 pins), 2.2 V	64 QFP-FU

2

**Table 1. 68HC05 General-Purpose Microcontrollers (continued)**

Part Number	ROM (Bytes)	RAM (Bytes)	EEPROM Bytes	Timer	Serial	A/D	PWM	Display Drive	I/O	COP	Comments	Package
MC68HC05L16	16K	512		16-bit: (11C, 10C) RTI 8-bit: (11C, 10C)	SIOP			156 Segment LCD: (1-4 x 27-39)	16 i/o 8 i 15 o	✓	KBI (8 pins), Dual Oscillators 8 High Current Pins (10 mA sink) Programmable Pullups (24 pins) Open-Drain (31 pins), 2.2 V Operation	80 QFP-FU
XC68HC05M4	4K	128		16-bit: (11C, 10C) 8-bit Modulo		6 ch (8-bit)		VFD (24 lines)	32 i/o 8 i	✓	5 V Only	52 PLCC-FN
XC68HC05M6	6K	208		16-bit: (11C, 10C) MFT, RTI				VFD: Grid Drive (12 bits) Anode Drive (38 bits)	7 i/o 50 o	✓	KBI (5 pins) 5 V Only	64 QFP-FU 68 PLCC-FN
MC68HC05P1	2K	128		16-bit: (11C, 10C)					20 i/o 1 i		68HSC05P1 High Speed Version	28 DIP-P 28 SOIC-DW
XC68HC05P1A	2K	128		16-bit: (11C, 10C)					20 i/o 1 i	✓	KBI (8 pins) Mask Option Pullups (8 pins) 2 High Current Pins (20 mA)	28 DIP-P 28 SOIC-DW
MC68HC05P2	3K	96		MFT, RTI	I <sup>2</sup> C				22 i/o	✓	I <sup>2</sup> C (Slave Only)	32 QFP-FB
XC68HC05P3	3K	128	128	16-bit: (11C, 10C) MFT, RTI					22 i/o	✓	KBI (6 pins) On-Chip Charge Pump	28 DIP-P 28 SOIC-DW
MC68HC05P4	4K	176		16-bit: (11C, 10C)	SIOP				20 i/o 1 i	✓		28 DIP-P 28 SOIC-DW
MC68HC05P5	3K	128		16-bit: (11C, 10C)			2 ch (8-bit)		15 i/o 3 i 3 o	✓	On-Chip Analog Comparator Mask Option Pullups (15 pins)	28 SOIC-DW
MC68HC05P6	4K	176		16-bit: (11C, 10C)	SIOP	4 ch (8-bit)			20 i/o 1 i	✓		28 DIP-P 28 SOIC-DW
MC68HC05P7	2K	128		16-bit: (11C, 10C)	SIOP				20 i/o 1 i	✓		28 DIP-P 28 SOIC-DW
MC68HC05P8	2K	112	32	MFI, RTI		4 ch (8-bit)			16 i/o 4 i	✓	LVPI Option on EEPROM On-Chip Charge Pump	28 DIP-P 28 SOIC-DW
MC68HC05P9	2K	128		16-bit: (11C, 10C)	SIOP	4 ch (8-bit)			20 i/o 1 i	✓		28 DIP-P 28 SOIC-DW
XC68HC05P10	2K	128		16-bit: (11C, 10C)	SIOP				20 i/o 1 i	✓	Mask Option Pullups (12 pins) 8 High Current Pins (15 mA sink)	28 DIP-P 28 SOIC-DW
XC68H05P15	3K	128		16-bit: (11C, 10C)			2 ch (8- or 16-bit)		15 i/o 3 i 1 o	✓	PEP (64 bytes) On-Chip Analog Comparator	28 SOIC-DW

2

**Table 1. 68HC05 General-Purpose Microcontrollers (continued)**

Part Number	ROM (Bytes)	RAM (Bytes)	EEPROM Bytes	Timer	Serial	A/D	PWM	Display Drive	I/O	COP	Comments	Package
XC68HC05PE0	2K	128		16-bit: (11C, 10C)					20 i/o	✓	1 High Current Pin (20 mA sink) PEP (64 bits), KBI (8 pins) Mask Option Pulldowns (8 pins) RC Oscillator Option	28 DIP-P 28 SOIC-DW
XC68HC05SC11	6K	128							5 i/o		Security Features Smart Card Applications 5 V Only	Die 16 DIP-P 20 SOIC-DW
XC68HC05SC21	6K	128	3K						5 i/o		Security Features On-Chip Charge Pump Smart Card Applications 5 V Only	Die 16 DIP-P 20 SOIC-DW
XC68HC05SC24	3K	128	1K						5 i/o		Security Features On-Chip Charge Pump Smart Card Applications 5 V Only	Die 16 DIP-P 20 SOIC-DW
XC68HC05SC27	16K	240	3K						5 i/o		Security Features On-Chip Charge Pump Smart Card Applications 5 V Only	Die 16 DIP-P 20 SOIC-DW
MC68HC05T1	8K	320		16-bit: (11C, 10C)	SIOP	1 ch (6-bit)	9 ch (6-bit)	OSD (64 Char ROM)	29 i/o 1 i	✓	Open Drain PWM Outputs 5 V Only	40 DIP-P 42 SDIP-B
XC68HC05T2	15K	320		16-bit: (11C, 10C)	SIOP	1 ch (6-bit)	9 ch (6-bit)	OSD (64 Char ROM)	29 i/o 1 i	✓	Open Drain PWM Outputs 5 V Only	40 DIP-P 42 SDIP-B 44 PLCC-FN
XC68HC05T3	24K	512		16-bit: (11C, 10C)	SIOP	1 ch (6-bit)	9 ch (6-bit)	OSD (112 Char ROM)	29 i/o 1 i	✓	Open Drain PWM Outputs 5 V Only	40 DIP-P
XC68HC05T4	5K	96		16-bit: (11C, 10C) 8-bit Pulse Accum.		1 ch (4-bit)	5 ch (6-bit)	OSD (64 Char ROM)	16 i/o 1 i	✓	Open Drain PWM Outputs 5 V Only	42 SDIP-B
MC68HC05T7	8K	320		16-bit: (11C, 10C) RTC	I <sup>2</sup> C	1 ch (8-bit)	8 ch (6-bit) 1 ch (14-bit)	OSD (64 Char ROM)	20 i/o 4 i		Open Drain PWM Outputs KBI (8 pins) 5 V Only	56 SDIP-B
MC68HC05T10	12K	320		16-bit: (11C, 10C) RTC	I <sup>2</sup> C	1 ch (8-bit)	8 ch (6-bit) 1 ch (14-bit)	OSD (64 Char ROM)	20 i/o 4 i		Open Drain PWM Outputs KBI (8 pins) 5 V Only	56 SDIP-B

**Table 1. 68HC05 General-Purpose Microcontrollers (continued)**

Part Number	ROM (Bytes)	RAM (Bytes)	EEPROM Bytes	Timer	Serial	A/D	PWM	Display Drive	I/O	COP	Comments	Package
XC68HC05T12	8K	320		16-bit: (11C, 10C) 8-bit Pulse Accum.	I <sup>2</sup> C	1 ch (4-bit)	8 ch (7-bit) 1 ch (14-bit)	OSD (64 Char ROM)	32 i/o 4 i		12 Open Drain Outputs KBI (8 pins) 5 V Only	56 SDIP-B
XC68HC05X4	4K	176		16-bit: (11C, 10C) MFT, RTI					16 i/o	✓	CAN (Controller Area Network) KBI (16 pins)	28 SOIC-DW
XC68HC05X16	15K	352	255	16-bit: (21C, 20C)	SCI	8 ch (8-bit)	2 ch (8-bit)		32 i/o	✓	CAN (Controller Area Network) KBI (8 pins) EEPROM Write Protect On-Chip Charge Pump	64 QFP-FU 68 PLCC-FN

2

## ONE-TIME PROGRAMMABLE (OTP) / EMULATOR MCUs

All 68HC705 products have a standard operating voltage range from 3 V to 5.5 V unless noted in Comments.  
All 68HC705 products have a standard operating temperature range from 0-70°C. Contact a Motorola Sales Office for availability of extended temperature versions.

**Table 2. MC68HC05 One-Time Programmable/Emulator Microcontrollers**

Part Number	EROM (Bytes)	RAM (Bytes)	EEPROM (Bytes)	Timer	Serial	A/D	PWM	Display Drive	I/O	COP	Comments	Packages
MC68HC705B5	6K	176		16-bit: (21C, 20C)	SCI	8 ch (8-bit)	2 ch (8-bit)		24 i/o 8 i 2 o	✓	Programmable Pulldowns (16 pins) EPROM Write Protect	56 SDIP - B 52 PLCC - FN
MC68HC705B16	15K	352	255	16-bit: (21C, 20C)	SCI	8 ch (8-bit)	2 ch (8-bit)		32 i/o 2 o	✓	On-Chip Charge Pump EEPROM Write Protected KBI (8 pins)	52 PLCC - FN
XC68HC705C5	5K	176	128	16-bit: (11C, 10C)	SIOP				32 i/o	✓	8 High Current Pins (10 mA sink) LVPI for EEPROM On-Chip Charge Pump	40 DIP - P *40 Cerdip - S 44 PLCC - FN
MC68HC705C8	8K	304		16-bit: (11C, 10C)	SPI SCI				28 i/o 3 i	✓	High Speed Option (HSC705C8)	40 DIP - P 44 PLCC - FN 42 SDIP - B 44 QFP - FB *40 Cerdip - S *44 Cerquad-FS
XC68HC705C8A	8K	304		16-bit: (11C, 10C)	SPI SCI				28 i/o 3 i	✓	Mask Option Register Pullups (8 pins) KBI (8 pins) 1 High Current Pin (20 mA sink)	40 DIP - P 44 PLCC - FN *40 Cerdip - S
XC68HC705C9	16K	352		16-bit: (11C, 10C)	SPI SCI				27 i/o 3 i 1 o	✓		40 DIP - P *40 Cerquad-FS 44 PLCC - FN
XC68HC705D9	16K	352		16-bit: (11C, 10C)	SCI		5 ch (6-bit)		27 i/o 3 i	✓	8 High Current Pins (25 mA)	40 DIP - P *40 Cerquad-FS

**Table 2. MC68HC05 One-Time Programmable/Emulator Microcontrollers (continued)**

Part Number	EROM (Bytes)	RAM (Bytes)	EEPROM (Bytes)	Timer	Serial	A/D	PWM	Display Drive	I/O	COP	Comments	Packages
				10C)					1 o		sink) 30 kHz PWM	44 PLCC - FN
MC68HC705E1	4K	368		MFT, RTC RTI					20 i/o	✓	32 kHz PLL Clock Synthesizer	*28 Cerdip - S 28 DIP - P 28 SOIC - DW
XC68HC705E24	24K	352	320	16-bit: (2IC, 20C) MFT	I <sup>2</sup> C	2 ch (8-bit)			47 i/o 2 i	✓	32 kHz PLL Clock Synthesizer LVI, On Chip Charge Pump KBI (8 pins)	64 QFP - FU
XC68HC705F4	8K	256	256	16-bit: (2IC, 20C) MFT, RTI					32 i/o	✓	KBI (8 pins) DTMF Generator LVI, On-Chip Charge Pump On-Chip OSC (2 selectable Freq.)	44 QFP - FB 28 SOIC - DW 28 DIP - P *44 Cerquad-FS 44 PLCC - FN
XC68HC705F6	4K	320		16-bit: (1IC, 10C)	SPI				26 i/o 4 i		DTMF Generator 8 High Current Pins (10 mA sink) KBI (6 pins)	42 SDIP - B *42 Cersdip - K 64 QFP - FU *64 CQFP - FZ
XC68HC705F8	8K	320		16-bit: (1IC, 10C) 16-bit: auto	SPI				50 i/o 2 o	✓	DTMF Generator KBI (8 pins) 8 High Current Pins (10 mA sink) Manchester Encoder/ Decoder	64 QFP - FU *64 CQFP - FZ
MC68HC705G1	12K	176		16-bit: (1IC, 10C) RTC	SPI	4 ch (8-bit)			40 i/o 8 i	✓	32 kHz PLL	56 SDIP - B 64 QFP - FU
MC68HC705G4	32K	1024		16-bit: (1IC, 10C) 8-bit: Event Cntr	Dual SPI	8 ch (8-bit)	4 ch (8-bit)		48 i/o 16 i 4 o	✓	KBI (8 pins) Dual IRQ Dual Oscillators Selectable Clock	80 QFP - FU *80 CQFP - FZ
XC68HC705G9	12K	304		MFT, RTC	PIO 2SIO	8 ch (8-bit)	4 ch (8-bit)		40 i/o 24 i	✓	Power Management IDE Interface KBI (8 pins) Keyboard Controller 32 kHz PLL, Host Address Decoder 4 Programmable Chip Selects	160 QFP - FT *160 CQFP - FZ

2

**Table 2. MC68HC05 One-Time Programmable/Emulator Microcontrollers (continued)**

Part Number	EROM (Bytes)	RAM (Bytes)	EEPROM (Bytes)	Timer	Serial	A/D	PWM	Display Drive	I/O	COP	Comments	Packages
XC68HC705G10	12K	304		MFT, RTC		5 ch (8-bit)	4 ch (8-bit)		39 i/o 23 i	✓	KBI (8 pins), KBI (8 pins), Keyboard Controller 4 Programmable Chip Selects 32 KHz PLL, Host Address Decoder 100 Pin Version of G9, Power Management	100 QFP - FU *100 CQFP - FZ
XC68HC705H2	2K	128		MFT, RTI	SIOP		2 ch (8-bit)		16 i/o	✓	4 LDMOS Power Output Drivers w/Switch, Driver, and H-Bridge Modes 4 Voltage Comparators	40 DIP - P 44 PLCC - FN 42 SDIP - B
XC68HC705I8	8K	224		16-bit: (2IC, 2OC) RTI	Dual SCI				42 i/o	✓	68000 Interface Module Receiver Wake-up	64 QFP - FU 68 PLCC - FN *68 Cerquad-FS
MC68HC705J2	2K	112		MFT, RTI					14 i/o	✓		20 DIP - P 20 SOIC - DW *20 Cerdip - S
XC68HC705J3	2K	128		16-bit: (1IC, 1OC) MFT RTI					14 i/o	✓	14 High Current Pins (8 mA sink) KBI (4 pins)	20 SOIC - DW
XC68HC705K1	0.5K	32		MFT, RTI					10 i/o	✓	4 High Current Pins (8 mA sink) PEP (64 bits) Programmable Pulldowns (10 pins)	16 DIP - P 16 SOIC - DW *16 Cerdip - S
XC68HC705L1	6K	128		16-bit: (2IC, 2OC)		6 ch (8-bit)		64 Segment LCD: (3/4 x 12/16)	17 i/o 15 i 2 o			56 SDIP - B 64 QFP - FU *64 CQFP - FZ *56 Cersdip - K
XC68HC705L2	2K	96		16-bit: (1IC, 1OC) MFT, RTI	I <sup>2</sup> C	1 ch (8-bit)		45 Segment LCD: (3 x 15)	13 i/o	✓	Programmable Pullups (13 pins)	42 SDIP - B
MC68HC705L5	8K	256		16-bit: (1IC, 1OC) RTI 8-bit: (1IC, 1OC)	SIOP			156 Segment LCD: (1-4 x 27-39)	14 i/o 10 i 15 o		KBI (8 pins), Dual Oscillators 8 High Current Pins (10 mA sink) Programmable Pullups (24 pins) Open Drain (31 pins)	80 QFP - FU *80 CQFP - FZ

2

**Table 2. MC68HC05 One-Time Programmable/Emulator Microcontrollers (continued)**

Part Number	EROM (Bytes)	RAM (Bytes)	EEPROM (Bytes)	Timer	Serial	A/D	PWM	Display Drive	I/O	COP	Comments	Packages
MC68HC705L13	16K	512		16-bit: (1IC, 1OC) RTI	SSPI			128 Segment LCD: (3 x 33 or 4 x 32)	23 i/o 8 i 1 o	✓	KBI (8 pins), Remote Control Generator Dual Oscillators Buzzer Output Programmable Pullups (24 pins) Open Drain (31 pins)	64 QFP - FU *64 CQFP - FZ
MC68HC705L16	16K	512		16-bit: (1IC, 1OC) RTI 8-bit: (1IC, 1OC)	SIOP			156 Segment LCD: (1-4 x 27-39)	16 i/o 8 i 15 o	✓	KBI (8 pins), Dual Oscillators 8 High Current Pins (10 ma sink) Programmable Pullups (24 pins) Open Drain (31 pins)	80 QFP - FU *80 CQFP - FZ
XC68HC705P6	4K	176		16-bit: (1IC, 1OC)	SIOP	4 ch (8-bit)			20 i/o 1 i	✓		28 DIP - P 28 SOIC - DW *28 Cerdip - S
XC68HC705P9	2K	128		16-bit: (1IC, 1OC)	SIOP	4 ch (8-bit)			20 i/o 1 i	✓		28 DIP - P 28 SOIC - DW *28 Cerdip - S
XC68HC705T3	24K	512		16-bit: (1IC, 1OC) RTI	SIOP	1 ch (6-bit)	9 ch (6-bit)	OSD (112 Char EPROM)	29 i/o 1 i	✓	Open Drain PWM Outputs 5 V Only	40 DIP - P
XC68HC705T4	6K	96		16-bit: (1IC, 1OC) 8-bit Pulse Accum.		1 ch (4-bit)	5 ch (6-bit)	OSD (64 Char EPROM)	16 i/o 1 i	✓	Open Drain PWM Outputs 5 V Only	42 SDIP - B *42 Cersdip - K
XC68HC705T10	12K	320		16-bit: (1IC, 1OC) RTC	I <sup>2</sup> C	1 ch (8 bit)	8 ch (6-bit) 1 ch (14 bit)	OSD (64 char EPROM)	20 i/o 4 i		Open Drain PWM Outputs KBI (8 pins) 5 V Only	56 SDIP - B *56 Cersdip - K
XC68HC705T12	8K	320		16-bit: (1IC, 1OC) 8-bit Pulse Accum.	I <sup>2</sup> C	1 ch (4 bit)	8 ch (7 bit) 1 ch (14 bit)	OSD (64 Char ROM)	32 i/o 4 i		12 Open Drain Outputs KBI (8 pins) 5 V Only	56 DIP - P *56 Cersdip - K
XC68HC705X4	4K	176		16-bit: (1IC, 1OC) MFT, RTI					16 i/o	✓	CAN (Controller Area Network) KBI (16 pins)	28 SOIC - DW
MC68HC705X16	15K	352	255	16-bit: (2IC, 2OC)	SCI	8 ch (8-bit)	2 ch (6-bit)		32	✓	CAN (Controller Area Network) KBI (8 pins), On-Chip Charge Pump EEPROM Write Protect	64 QFP - FU 68 PLCC - FN *68 Cerquad-FS

\* Windowed packages available only in sample quantities.

2

<b>Definitions for Tables 1 and 2</b>			
<b>General Definitions</b>			
CAN	Controller Area Network	MMU	Memory Management Unit
CCTV	Closed Caption Television	o	Output Only Port Pins
COP	Computer Operating Properly (Watch Dog Timer)	OC	Output Compare
DTMF	Dual-Tone Multi-Frequency	OSD	On-Screen Display
EBI	External Bus Interface	PIO	Parallel Input Output (IBM PC/AT Type)
IC	Input Capture	PLL	Phase-Lock Loop
I <sup>2</sup> C	Inter-Integrated Circuit	PWM	Pulse-Width Modulation
IDE	Integrated Device Electronics (IBM PC/AT Type)	RTC	Real-Time Clock
i/o	Bidirectional Input and Output Port Pins	RTI	Real-Time Interrupt
i	Input Only Port Pins	SCI	Serial Communications Interface
KBI	Key Board Interrupt	SIO	Serial Input Output (IBM PC/AT Type)
LCD	Liquid Crystal Display	SIOP	Simple Serial I/O Port
LVI	Low-Voltage Interrupt	SPI	Serial Peripheral Interface
LVPI	Low Voltage Program Inhibit	SSPI	Simple Serial Peripheral Interface
LVR	Low Voltage Reset	VFD	Vacuum Fluorescent Display
MDLC	Message Data Link Controller	WDOG	Watch Dog Timer
MFT	Multi Function Timer		

2

<b>Definitions for Tables 1 and 2</b>	
<b>Package Definitions</b>	
B	Shrink Dual-in-Line Plastic
DW	Small Outline (Wide-Body SOIC)
FA	7 x 7 mm Quad Flat Pack (QFP)
FB	10 x 10 mm Quad Flat Pack (QFP)
FN	Plastic Quad (PLCC)
FS	Cerquad (windowed) — Samples Only
FT	28 x 28 mm Quad Flat Pack (QFP)
FU	14 x 14 mm Quad Flat Pack (QFP)
FZ	CQFP (windowed) — Samples Only
K	Cerdip (windowed) — Samples Only
L	Ceramic Sidebrazed
P	Dual-in-Line Plastic
S	Cerdip (windowed) — Samples Only



## M68HC08 Family

The M68HC08 Family offers a unique combination of high-speed, low-power, enhanced processing performance for cost-sensitive 8-bit applications. Full upward object code compatibility with the world's leading 8-bit microcontroller allows current M68HC05 users to leverage their resource and time investment. M68HC08 modular design utilizes a growing library of on-chip peripherals. Future family members will integrate special technologies like fuzzy logic and DSP for embedded control applications.

### Features

- Architecturally enhanced 8-bit CPU
  - 8 MHz bus speed yields 125ns minimum instruction cycle
  - 16-bit stack with stack pointer operations and addressing modes
  - 16-bit index register
  - 78 new instructions including advanced looping control
  - Eight new addressing modes
- Fully upward object code compatible with the M68HC05 and M6805 families
- Direct Memory Access module
  - Memory-to-memory transfer
  - Peripheral-to-memory and memory-to-peripheral transfer
- Timing Interface Module
  - Four independently programmable channels
  - Input capture, output compare, buffered and unbuffered PWM configurations
- Interface modules
  - Serial Communications Interface (UART)
  - Serial Peripheral Interface
- System Control Modules
  - Low voltage inhibit, PLL, COP, and System Integration Module

OTP versions of M68HC08 devices will be available mid 1994.

ROM versions available in the end of 1994.

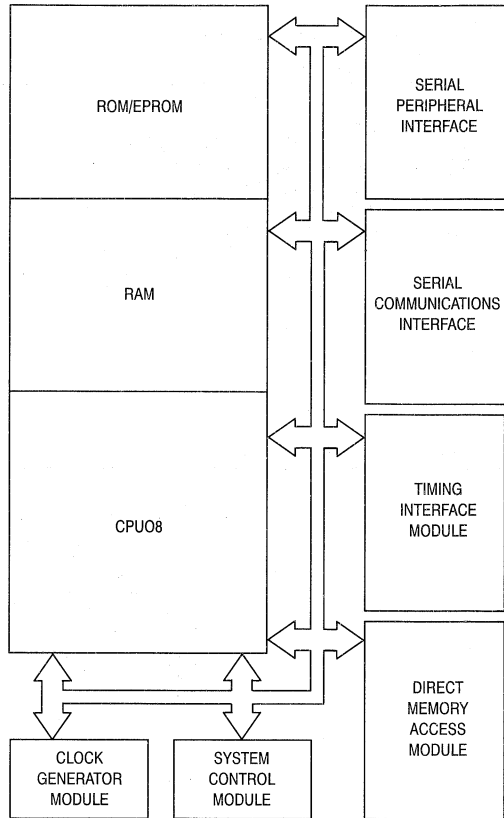

Figure 5. Block Diagram of Typical M68HC08 MCU

# M68HC11 Family

The M68HC11 Family incorporates a flexible central processing unit and a large number of control-oriented on-chip peripherals. M68HC11 MCU are upward code compatible with M6800, M6801, and M68HC05 software.

## Central Processing Unit

The M68HC11 CPU is optimized for low power consumption and high-performance operation at bus frequencies up to 4 MHz. Key features include:

- Two 8-bit or one 16-bit accumulator
- Two 16-bit index registers
- Powerful bit-manipulation instructions
- Six powerful addressing modes
  - Immediate, Extended, Direct, Indexed, Inherent, and Relative
- Power saving STOP and WAIT modes
- Memory mapped I/O and special functions
- 16x16 Integer and Fractional Divides
- 8x8 Multiply

## Timer

M68HC11 timer architecture is based on a 16-bit free running counter driven through a software-programmable prescaler. Features include multiple Input Captures, Output Compares, Real-Time Interrupt, Pulse Accumulator, and Watchdog functions.

## On-Chip Memory

Since its introduction, the M68HC11 Family has provided versatile combinations of popular memory technologies, including the first EEPROM on a CMOS microcontroller. The family has a memory option to fit virtually any application.

- ROM sizes range from 0 to 32K bytes. ROM is typically factory programmed to contain custom software. ROMless versions of most M68HC11 Family members are also available.
- RAM sizes range from 192 bytes to 1.25K bytes. M68HC11 RAM utilizes a fully static design, and all devices feature a standby power supply pin for battery back-up of RAM contents.
- EPROM sizes range from 4K to 32K bytes. EPROM is especially suited to prototype development and small production runs. EPROM versions are available in both windowed and OTP packaging.
- EEPROM sizes range from 0 to 2K bytes. EEPROM is ideal for storage of calibration, diagnostic, data logging, and security information. Each M68HC11 device with EEPROM includes an on-chip charge pump to facilitate single-supply programming and erasing.

## Digital-to-Analog Conversion

The M68HC11 Family provides powerful, on-chip, multi-channel A/D converter systems. Multi-conversion and multi-channel options allow single or continuous conversion on single or multiple channels. M68HC11 A/D systems have

eight input channels, and most offer 8-bit resolution, although some provide 10-bit resolution. A 2 channel, 8-bit D/A is also available.

## Pulse-Width Modulation

Some M68HC11 Family members have up to six channels of 8-bit PWM. At a 4 MHz bus frequency, signals can be produced from 40 KHz to less than 10 Hz. PWM signals with a period greater than one minute are possible in the 16-bit mode.

## Serial Communication

All members of the M68HC11 Family include a Serial Peripheral Interface (SPI) and a Serial Communications Interface (SCI). These on-chip peripherals are designed to minimize CPU intervention during data transfer.

- The SCI is a full duplex UART-type asynchronous system that uses standard Non-Return-to-Zero (NRZ) data format. An on-chip Baud rate generator derives standard rates from the microcontroller oscillator. Both transmitter and receiver are double buffered.
- The SPI is a four-wire synchronous communications interface used for high-speed communication with specialized peripheral devices and other microcontrollers. Data is transmitted and received simultaneously; the Baud rate is software programmable.

2

## Digital I/O and Special Functions

M68HC11 Family I/O is extremely flexible, allowing pins to be configured to match application requirements. Most I/O lines are controlled by bits in a Data Direction Register (DDR) which can configure pins for either input or output. Most lines have a dedicated port data latch.

Some M68HC11 Family members include a 4-channel Direct Memory Access (DMA) and a Memory Management Unit (MMU). The DMA provides fast data transfer between memories and registers, and includes externally mapped memory in the expanded mode. The MMU allows up to 1 megabyte of address space in a physical 64 kbyte allocation. Integrated chip selects help to reduce glue logic.

Several members of the M68HC11 Family also include programmable chip select circuits. These circuits can be used to enable external peripherals whenever an access to a predefined block of memory addresses is made. These circuits help to reduce external logic requirements.

## Math Coprocessor

New M68HC11 Family members offer a 16-bit on-chip math coprocessor that accelerates multiply and divide operations by as much as 10 times. The coprocessor functions independently of the CPU and requires no special instructions. The coprocessor is well-suited to low-bandwidth DSP functions such as closed loop control, servo positioning, and signal conditioning.

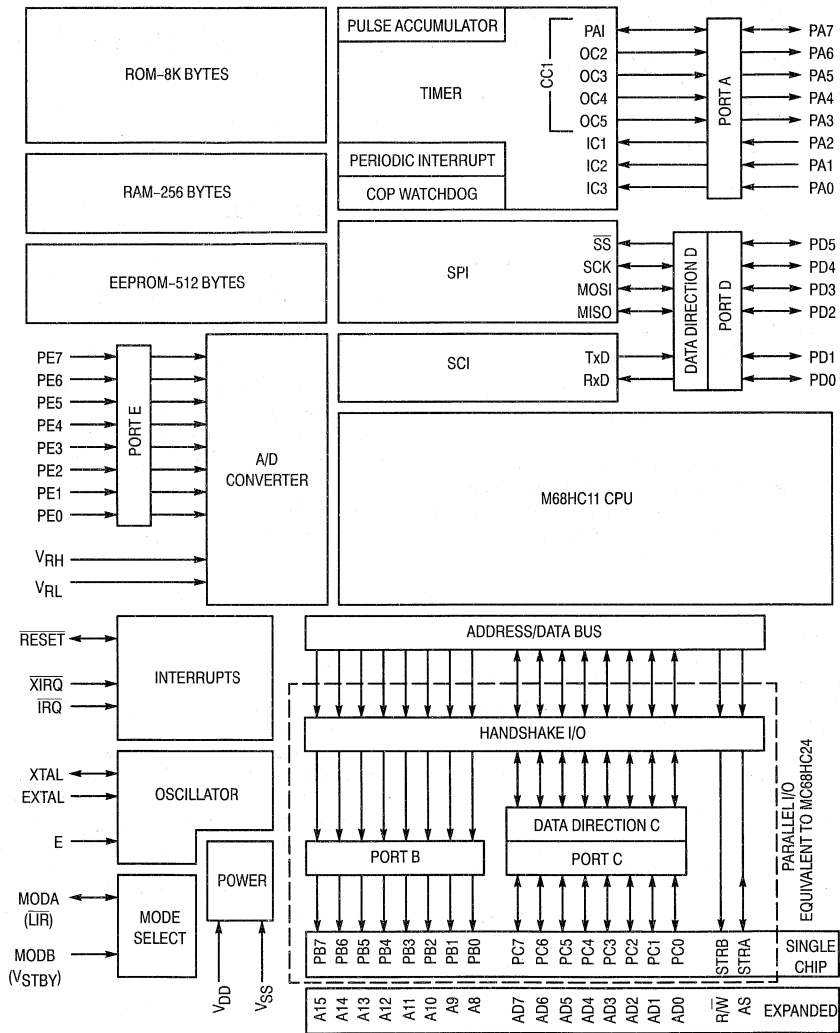

Figure 6. MC68HC11A8 Block Diagram

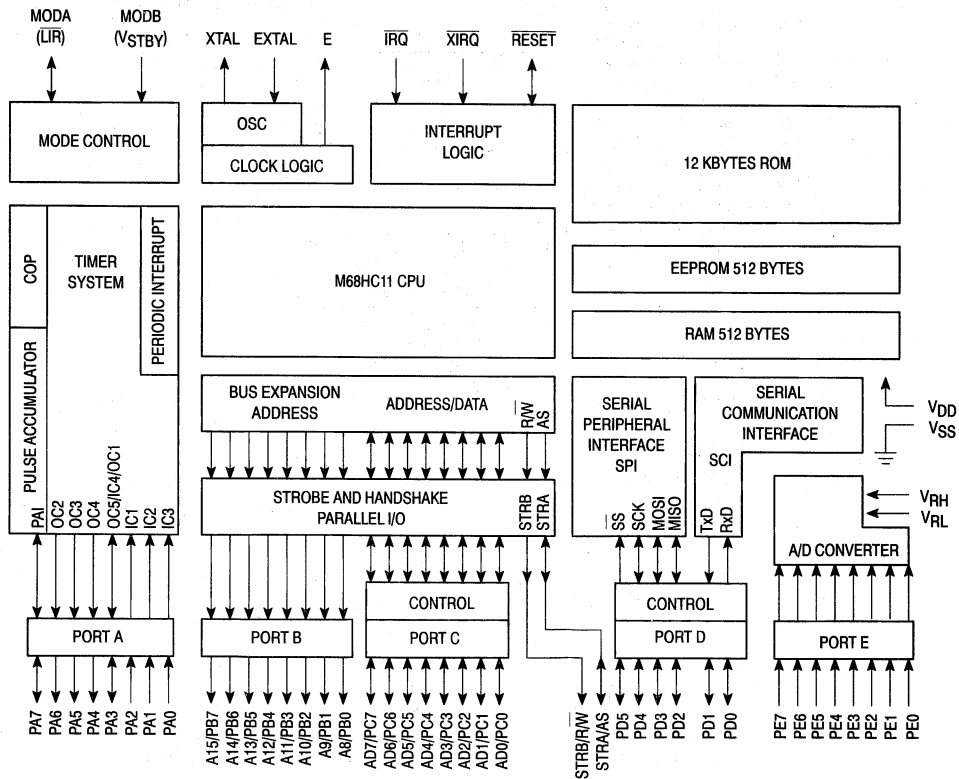

Figure 7. MC68HC11E9 Block Diagram

2

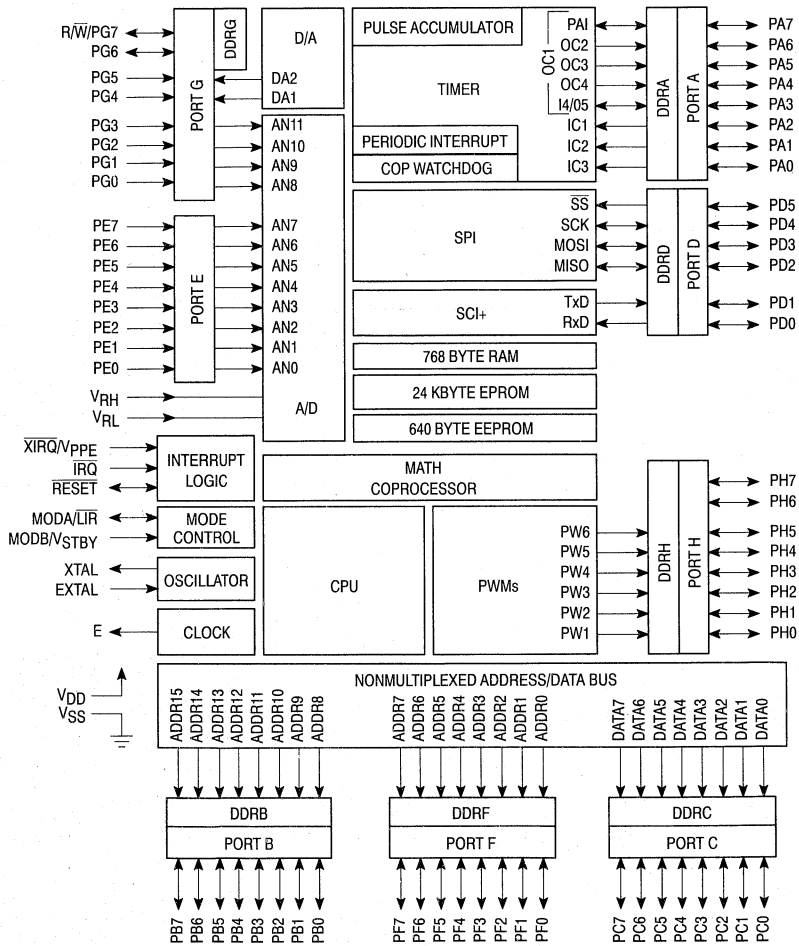

Figure 8. MC68HC711N4 Block Diagram

**Table 3. M68HC11 Family Microcontrollers**

Part Number	EPROM	RAM	EEPROM	Timer	I/O	Serial	A/D	PWM	Package	Comments
MC68HC11A0	-	256	-	16-Bit - 3 IC, 5 OC, RTI, WDOG Pulse Accumulator	22	SPI, SCI	8 Ch, 8-Bit	-	52-FN 64-FU 48-P	64K External Address Bus, 68HC24 PRU, 3.0 V Version Available
MC68HC11A1	-	256	512	16-Bit - 3 IC, 5 OC, RTI, WDOG Pulse Accumulator	22	SPI, SCI	8 Ch, 8-Bit	-	52-FN 64-FU 48-P	64K External Address Bus, 68HC24 PRU, 3.0 V Version Available
MC68HC11A7	8K	256	-	16-Bit - 3 IC, 5 OC, RTI, WDOG Pulse Accumulator	38	SPI, SCI	8 Ch, 8-Bit	-	52-FN 64-FU 48-P	3 MHz Version Available, 64K External Address Bus, 68HC24 PRU, 3.0 V Version Available
MC68HC11A8	8K	256	512	16-Bit - 3 IC, 5 OC, RTI, WDOG, Pulse Accumulator	38	SPI, SCI	8 Ch, 8-Bit	-	52-FN 48-P	3 MHz Version Available, Low Voltage Version (3.0-5.5V) at 2 MHz, 64K External Address Bus, 68HC24 PRU
XC68HC11C0	-	256	512	16-Bit - 3/4 IC, 4/5 OC, RTI, WDOG, Pulse Accumulator	36	SPI, SCI	4 Ch, 8-Bit	2 Ch, 8-Bit	68-FN 64-FU	256K Externed Memory, 6 Chip Selects
MC68HC11D0	-	192	-	16-Bit - 3/4 IC, 4/5 OC, RTI, WDOG, Pulse Accumulator	14	SPI, SCI	-	-	44-FB 44-FN 40-P	64K External Address Bus, 68HC27 PRU, 3.0V Version Available
MC68HC11D3	4K	192	-	16-Bit - 3/4 IC, 4/5 OC, RTI, WDOG, Pulse Accumulator	32	SPI, SCI	-	-	44-FB 44-FN 40-P	3 MHz Version Available, Low Voltage Version (3.0-5.5V) at 2 MHz, 64K External Address Bus, 68HC27 PRU
MC68HC11ED0	-	512	-	16-Bit - 3/4 IC, 4/5 OC, RTI, WDOG, Pulse Accumulator	30	SPI, SCI	-	-	44-FB 44-FN 40-P	Pin Compatible with 68HC11D3
MC68HC11E0	-	512	-	16-Bit - 3/4 IC, 4/5 OC, RTI, WDOG, Pulse Accumulator	22 SCI	SPI, 8-Bit	8 Ch,	-	52-FN	64K External Address Bus, 68HC24 PRU, 3.0 V Version Available
MC68HC11E1	-	512	512	16-Bit - 3/4 IC, 4/5 OC, RTI, WDOG, Pulse Accumulator	22	SPI, SCI	8 Ch, 8-Bit	-	52-FN 64-FU	64K External Address Bus, EEPROM Block Protect, 68HC24 PRU, 3.0 V Version Available
MC68HC11E8	12K	512	-	16-Bit - 3/4 IC, 4/5 OC, RTI, WDOG, Pulse Accumulator	38 SCI	SPI, 8-Bit	8 Ch,	-	52-FN	3 MHz Version Available, 64K External Address Bus, 3.0 V Version Available
MC68HC11E9	12K	512	512	16-Bit - 3/4 IC, 4/5 OC, RTI, WDOG, Pulse Accumulator	38	SPI, SCI	8 Ch, 8-Bit	-	52-FN 64-FU	EEPROM Block Protect, 3 MHz Version Available, Low Voltage Version (3.0-5.5V) at 2 MHz, 64K External Address Bus
XC68HC11E20	20K	768	512	16-Bit - 3/4 IC, 4/5 OC, RTI, WDOG, Pulse Accumulator	38	SPI, SCI	8 Ch, 8-Bit	-	52-FN 64-FU	3 MHz Mux Bus
MC68HC811E2	-	256	2048	16-Bit - 3/4 IC, 4/5 OC, RTI, WDOG, Pulse Accumulator	38	SPI, SCI	8 Ch, 8-Bit	-	52-FN	EEPROM Block Protect, 64K External Address Bus, 68HC24 PRU
MC68HC11F1	-	1K	512	16-Bit - 3/4 IC, 4/5 OC, RTI, WDOG, Pulse Accumulator	54	SPI, SCI	8 Ch, 8-Bit	-	68-FN 80-FU	Programmable Chip Selects, EEPROM Block Protect, 64K External Address Bus, 68HC27 PRU, 4 MHz Non-Mux Address/Data Bus

**2**

**Table 3. M68HC11 Family Microcontrollers (continued)**

Part Number	EPROM	RAM	EEPROM	Timer	I/O	Serial	A/D	PWM	Package	Comments
PC68HC11G0	-	-	512	16-Bit - 3/4 IC, 4/5 OC, RTI, WDOG, Pulse Accumulator	38	SPI, SCI	8 Ch, 10-Bit	4 Ch, 8-Bit	84-FN 80-FU	
PC68HC11G5	16K	512	-	16-Bit - 3/4 IC, 4/5 OC, RTI, WDOG, Pulse Accumulator	66	SPI, SCI	8 Ch, 10-Bit	4 Ch, 8-Bit	84-FN 80-FU	
PC68HC11G7	24K	512	-	16-Bit - 3/4 IC, 4/5 OC, RTI, WDOG, Pulse Accumulator	66	SPI, SCI	8 Ch, 10-Bit	4 Ch, 8-Bit	84-FN 80-FU	
PC68HC11J6	16K	-	512	16-Bit - 3/4 IC, 4/5 OC, RTI, WDOG, Pulse Accumulator	29	SPI, SCI	8 Ch, 8-Bit	4 Ch, 8-Bit	84-FN 80-FU	
MC68HC11K0	-	768	-	16-Bit - 3/4 IC, 4/5 OC, RTI, WDOG, Pulse Accumulator	37	SPI, SCI	8 Ch, 8-Bit	4 Ch, 8-Bit	84-FN 80-FU	4 MHz Non-Mux Address/Data Bus, Chip Selects, Extended Memory Map, 68HC27 PRU, 3.0 V Version Available
MC68HC11KA0	-	768	-	16-Bit - 3/4 IC, 4/5 OC, RTI, WDOG, Pulse Accumulator	26	SPI, SCI	8 Ch, 8-Bit	4 Ch, 8-Bit	68-FN 64-FU	4 MHz Non-Mux Address/Data Bus, Chip Selects, Extended Memory Map, 68HC27 PRU
MC68HC11K1	-	768	640	16-Bit - 3/4 IC, 4/5 OC, RTI, WDOG, Pulse Accumulator	37	SPI, SCI	8 Ch, 8-Bit	4 Ch, 8-Bit	84-FN 80-FU	4 MHz Non-Mux Bus, Chip Selects, EEPROM Block Protect, Extended Memory Map, 68HC27 PRU, 3.0 V Version Available
MC68HC11KA1	-	768	640	16-Bit - 3/4 IC, 4/5 OC, RTI, WDOG, Pulse Accumulator	26	SPI, SCI	8 Ch, 8-Bit	4 Ch, 8-Bit	68-FN 64-FU	4 MHz Non-Mux Address/Data Bus, Chip Selects, EEPROM Block Protect, Extended Memory Map, 68HC27 PRU
MC68HC11K3	24K	768	-	16-Bit - 3/4 IC, 4/5 OC, RTI, WDOG, Pulse Accumulator	62	SPI, SCI	8 Ch, 8-Bit	4 Ch, 8-Bit	84-FN 80-FU	4 MHz Non-Mux Address/Data Bus, Chip Selects, Extended Memory Map, 68HC27 PRU, 3.0V Version Available
MC68HC11KA3	24K	768	-	16-Bit - 3/4 IC, 4/5 OC, RTI, WDOG, Pulse Accumulator	51	SPI, SCI	8 Ch, 8-Bit	4 Ch, 8-Bit	68-FN 64-FU	4 MHz Non-Mux Address/Data Bus, Chip Selects, Extended Memory Map, 68HC27 PRU
MC68HC11K4	24K	768	640	16-Bit - 3/4 IC, 4/5 OC, RTI, WDOG, Pulse Accumulator	62	SPI, SCI	8 Ch, 8-Bit	4 Ch, 8-Bit	84-FN 80-FU	4 MHz Non-Mux Bus, Low Voltage Version (3.0-5.5V) at 3 MHz, Chip Selects, EEPROM Block Protect, Extended Memory Map, 68HC27 PRU
MC68HC11KA4	24K	768	640	16-Bit - 3/4 IC, 4/5 OC, RTI, WDOG, Pulse Accumulator	51	SPI, SCI	8 Ch, 8-Bit	4 Ch, 8-Bit	68-FN 64-FU	4 MHz Non-Mux Address/Data Bus, Chip Selects, EEPROM Block Protect
MC68HC11L0	-	512	-	16-Bit - 3/4 IC, 4/5 OC, RTI, WDOG, Pulse Accumulator	30	SPI, SCI	8 Ch, 8-Bit	-	68-FN 64-FU	64K External Address Bus, 68HC24 PRU, 3.0 V Version Available
MC68HC11L1	-	512	512	16-Bit - 3/4 IC, 4/5 OC, RTI, WDOG, Pulse Accumulator	46	SPI, SCI	8 Ch, 8-Bit	-	68-FN 64-FU	64K External Address Bus, EEPROM Block Protect, 68HC24 PRU, 3.0 V Version Available
MC68HC11L5	16K	512	-	16-Bit - 3/4 IC, 4/5 OC, RTI, WDOG, Pulse Accumulator	46	SPI, SCI	8 Ch, 8-Bit	-	68-FN 64-FU	64K External Address Bus, 68HC24 PRU, 3.0 V Version Available

**2**

**Table 3. M68HC11 Family Microcontrollers (continued)**

Part Number	EPROM	RAM	EEPROM	Timer	I/O	Serial	A/D	PWM	Package	Comments
MC68HC11L6	16K	512	512	16-Bit – 3/4 IC, 4/5 OC, RTI, WDOG, Pulse Accumulator	46	SPI, SCI	8 Ch, 8-Bit	–	68–FN 64–FU	3 MHz Version Available, Low Voltage Version (3.0–5.5V) at 2 MHz, 64K External Address Bus, 68HC24 PRU
MC68HC11M2	32K	1.25K	–	16-Bit – 3/4 IC, 4/5 OC, RTI, WDOG, Pulse Accumulator	62	SPI, 2–SCI	8 Ch, 8-Bit	4 Ch, 8-Bit	84–FN 80–FU	16-Bit Math Coprocessor, 4 MHz Non–Mux Bus, 4 Ch DMA Controller
XC68HC11N4	24K	768	640	16-Bit – 3/4 IC, 4/5 OC, RTI, WDOG, Pulse Accumulator	62	SPI, SCI	12 Ch, 8-Bit	6 Ch, 8-Bit	84–FN 80–QFP	16-Bit Math Coprocessor, 4 MHz Non–Mux Bus, 2 Ch 8-Bit D/A
XC68HC11P2	32K	1K	640	16-Bit – 3/4 IC, 4/5 OC, RTI, WDOG, Pulse Accumulator	62	SPI, 3–SCI	8 Ch, 8-Bit	4 Ch, 8-Bit	84–FN 80–FU	PLL Clock Option

**2**

**Table 4. M68HC11 One-Time Programmable/Emulator Microcontrollers**

Part Number	EPROM	RAM	EEPROM	Timer	I/O	Serial	A/D	PWM	Package	Comments
PC68HC711D3	4K	192	–	16-Bit – 3/4 IC, 4/5 OC, RTI, WDOG, Pulse Accumulator	32	SPI, SCI	–	–	44–FB 44–FN 40–P	64K External Address Bus
PC68HC711E9	12K	512	512	16-Bit – 3/4 IC, 4/5 OC, RTI, WDOG, Pulse Accumulator	38	SPI, SCI	8 Ch, 8-Bit	–	52–FN 64–FU	EEPROM Block Protect, 64K External Address Bus
PC68HC711E20	20K	768	512	16-Bit – 3/4 IC, 4/5 OC, RTI, WDOG, Pulse Accumulator	38	SPI, SCI	8 Ch, 8-Bit	–	52–FN 52–FS 64–FU	EEPROM Block Protect, 64K External Address Bus
PC68HC711G5	16K	512	–	16-Bit – 3/4 IC, 4/5 OC, RTI, WDOG, Pulse Accumulator	66	SPI, SCI	8 Ch, 10-Bit	4 Ch, 8-Bit	84–FN 84–FS	
PC68HC711J6	16K	512	–	16-Bit – 3/4 IC, 4/5 OC, RTI, WDOG, Pulse Accumulator	54	SPI, SCI	–	–	68–FN 68–FS	1 Chip Select
PC68HC711K4	24K	768	640	16-Bit – 3/4 IC, 4/5 OC, RTI, WDOG, Pulse Accumulator	62	SPI, SCI	8 Ch, 8-Bit	4 Ch, 8-Bit	84–FN 84–FS 80–FU	4 MHz Non–Mux Bus, EEPROM Block Protect, Chip Selects, Extended Memory Map
PC68HC711L6	16K	512	512	16-Bit – 3/4 IC, 4/5 OC, RTI, WDOG, Pulse Accumulator	46	SPI, SCI	8 Ch, 8-Bit	–	68–FN 68–FS 64–FU	EEPROM Block Protect, 64K External Address Bus
PC68HC711M2	32K	1.25K	–	16-Bit – 3/4 IC, 4/5 OC, RTI, WDOG, Pulse Accumulator	62	SPI, SCI	8 Ch, 8-Bit	–	84–FN 84–FS 80–FU	16-Bit Math Coprocessor, 4 MHz Non–Mux Bus, 4 Ch DMA Controller
PC68HC711N4	24K	768	640	16-Bit – 3/4 IC, 4/5 OC, RTI, WDOG, Pulse Accumulator	62	SPI, SCI	12 Ch, 8-Bit	6 Ch, 8-Bit	84–FN 84–FS	16-Bit Math Coprocessor, 4 MHz Non–Mux Bus, 2 Ch 8-Bit D/A
XC68HC711P2	32K	1K	640	16-Bit – 3/4 IC, 4/5 OC, RTI, WDOG, Pulse Accumulator	62	SPI, SCI	8 Ch, 8-Bit	4 Ch, 8-Bit	84–FN 84–FS 88–FU	PLL Clock



2

Definitions for Tables 3 and 4			
General Definitions		Package Definitions	
ADC	Analog to Digital Converter Module	FB	10x10 mm Quad Flat Pack (QFP)
A/D	Analog to Digital Converter	FC	Fine Pitch Plastic Quad Flat Pack (PQFP)
CPU16	16 bit Central Processing Unit	FD	Plastic Quad Flat Pack in Molded Carrier Ring
CPU32	32 bit Central Processing Unit	FE	Ceramic Quad Flat Pack (CQFP)
D/A	Digital to Analog Converter	FM	Molded Carrier Flat Pack (CQFP)
DMA	Direct Memory Access	FN	Plastic Leaded Chip Carrier (PLCC)
GPT	General-Purpose Timer	FS	Windowed Cerquad (Ceramic LCC)
IC	Input Capture	FT	28x28 mm Quad Flat Pack (QFP)
IIC	Inter-Integrated Circuit	FU	14x14 mm Quad Flat Pack (QFP)
MCCI	Multi-Channel Communication Interface	FV	20x20 mm Quad Flat Pack (QFP)
PLL	Phase Lock Loop	L	Ceramic
OC	Output Capture	P	Dual-in-Line Plastic
POQ	Preferred Order Quantity Multiple	PB	Thin Quad Flat Pack (TQFP) 10x10 mm
PWM	Pulse Width Modulation	PU	Thin Quad Flat Pack (TQFP) 14x14 mm
QSM	Queued Serial Module	PV	Thin Quad Flat Pack (TQFP) 20x20mm
RPSCIM	Reduced Pin Count SCIM	S	Cerdip (windowed or non-windowed)
RTC	Real-Time Clock	TH	16x16 mm Quad Flat Pack (QFP)
RTI	Real-Time Interrupt		
SCI	Serial Communication Interface		
SCIM	Single Chip Integration Module		
SIM	System Integration Module		
SPI	Serial Peripheral Interface		
TPU	Time Processing Unit		
UART	Universal Asynchronous Receiver/Transmitter		
WDOG	Watch Dog Timer		

# M6800 Series Microprocessors and Peripherals

These devices are a testament to the staying power of Motorola microtechnology. The original MC6800 was introduced in 1975, and is still in demand today. Quality M6801, M6804 and M6805 systems have been performing

reliably in automotive, industrial, and office equipment applications for years. Each of these devices can be combined with various peripherals to meet the requirements of a microcontroller design.

**Table 5. M6801 and M6803 (HMOS)**

Part Number	ROM	RAM	EEPROM	Timer	Serial	A/D	I/O	Bus Speed, MHz	Package	Comments
MC6801	2048	192	0	16 bit: 1 IC, 1 OC	SCI	No	29	0.5-2.0	40 P	
MC68701	0	128	2048	16 bit: 1 IC, 1 OC	SCI	No	29	0.5-2.0	40 P	
MC6803	0	192	0	16 bit: 1 IC, 1 OC	SCI	No	13	0.5-2.0	40 P	
MC6801U4	4096	256	0	16 bit: 2 IC, 3 OC	SCI	No	29	0.5-1.25	40 P	
MC68701U4	0	128	4096	16 bit: 2 IC, 3 OC	SCI	No	29	0.5-1.25	40 P	
MC6803U4	0	256	0	16 bit: 2 IC, 3 OC	SCI	No	13	0.5-1.25	40 P	

2

**Table 6. 8-Bit MPU/Peripherals**

Device	Pins	Package	Part Description	Speed
MC68B00	40	P	8 Bit MPU, Addresses 64K Memory, 1 or 2 MHz Versions	2 MHz
MC6802	40	P	MC6800 + Int. Clock Oscillator; 128 Bytes RAM	1 MHz
MC68B09	40	P	High Performance MPU, 10 Powerful Addressing Modes	2 MHz
MC68B09E	40	P	MC6809 With External Clock Input for External Sync.	2 MHz
MC68B21	40	P	Peripheral Interface Adapter	2 MHz
MC68B40	40	P	Programmable Timer Module Contains 3 16-Bit Timers	2 MHz
MC6845	40	P	CRT Ctrl, Refresh Memory Addressing; 2nd Source HD6845R	1 MHz
MC68B50	40	P	Asynchronous Communication Interface Adaptor	2 MHz
MC68HC24	40, 44	P, FN	MC68HC11 Port Replacement (Expanded Mode) for A8, E9	2 MHz
MC68HC27	46, 68	FU, FN	Port Replacement for D3, K4, F1	2 MHz
MC68HCB34	40	P, FN	256 Byte Dual Port RAM, 6 Semaphore Registers	2 MHz
MC68B10	24	P	128 x 8 Random Access Memory	2 MHz
MC68B44	40	P	Direct Memory Access Controller	2 MHz
MC68B488	40	P	General Purpose Interface Adapter	2 MHz
MC68B52	24	P	Synchronous Serial Data Adapter	2 MHz
MC68B54	28	P	Advanced Data Link Controller	2 MHz

**Table 7. M6805 (HMOS) Microprocessors**

Part Number	ROM	RAM	EEPROM	Timer	Serial	A/D	I/O	Bus Speed, MHz	Package	EPROM or EEPROM Version	Comments
MC6805P2	1K	64	0	8-Bit	–	No	20	0.1–1.0	28–P 28–FN	705P3	LVI Option
MC6805P6	2K	64	0	8-Bit	–	No	20	0.1–1.0	28–P	705P3	LVI Option
MC6805R2	2K	64	0	8-Bit	–	Yes	32	0.1–1.0	40–P 44–FN	705R3	LVI Option, Prog. Prescaler Option
MC6805R3	4K	112	0	8-Bit	–	Yes	32	0.1–1.0	40–P 44–FN	705R3	7-Bit Prescaler, LVI Option
MC6805R6	4K	112	0	8-Bit, WDOG	–	Yes	32	0.1–1.0	40–P 44–FN	705R3	7-Bit Prescaler, LVI Option
MC6805S2	1K	64	0	16-Bit, 8-Bit	SPI	Yes	16	0.1–1.0	28–P	705S3	15-Bit Prescaler, LVI
MC6805S3	4K	104	0	2 8-Bit, 16-Bit	SPI	Yes	21	0.1–1.0	28–P	705S3	1 Extra 8-Bit Timer
MC6805U2	2K	64	0	8-Bit	–	No	32	0.1–1.0	40–P 44–FN	705U3	LVI Option
MC6805U3	4K	112	0	8-Bit	–	No	32	0.1–1.0	40–P 44–FN	705U3	7-Bit Prescaler, LVI Option

**2**
**Table 8. 8-Bit MPU/Peripherals**

Device	Pins	Package	Part Description
MC14618	24	P	Real Time Clock, 50 Bytes RAM, Programmable Square Wave
MC146818A	24, 28	P, FN	Enhanced Version of the MC146818
MC146823	40, 44	P, FN	Three 8-Bit Ports, Handshake Control Logic
MC146805E2	40, 44	P, FN	CMOS 8-Bit Microprocessor
MC68HC68L9	80	FU	LCD Expansion to the MC05L9

# Modular Microcontrollers

Modular microcontrollers are another of the innovations that make Motorola a leader in single-chip control systems. Modular controllers are built up from standard modules that interface via a common intermodule bus (IMB). The modular concept allows rapid design and manufacture of controllers tailored for specific applications.

## Intermodule Bus Peripherals

Each modular microcontroller incorporates a state-of-the-art pipelined CPU module, a sophisticated integration module, and a number of special-purpose modules. The rapidly-growing library of special-purpose modules includes programmable timers, serial communication interfaces, analog-to-digital converters, and a variety of memory modules.

## Central Processing Units

### CPU16

- 16-Bit Architecture
- Full Set of 16-Bit Instructions
- Three 16-Bit Index Registers
- Two 16-Bit Accumulators
- One Megabyte of Program Memory and One Megabyte of Data Memory
- Source code compatible with the M68HC11 CPU
- Control-Oriented Digital Signal Processing Capability
- High-Level Language Support
- Fast Interrupt Response Time
- Fully Static Implementation
- Low Power Stop Operation
- Background Debugging Mode
- Hardware Breakpoint Signal

### CPU32

- 32-Bit Internal Data Path and Arithmetic Hardware
- 32-Bit Internal Address Bus – 24-Bit External Address Bus
- Eight 32-Bit General-Purpose Data Registers
- Seven 32-Bit General-Purpose Address Registers
- Separate User and Supervisor Stack Pointers and Address Spaces
- Separate Program and Data Address Spaces
- Virtual Memory Implementation
- Enhanced Addressing Modes
- Object Code Compatible with M68000 Family
- Improved Exception Handling for Controller Applications
- Rich Instruction Set
- Fully Static Implementation
- Low Power Stop Operation
- Background Debugging Mode
- Hardware and Software Breakpoints
- Trace on Change of Flow

## Integration Modules

### System Integration Module (SIM)

- Manages controller internal and external bus interfaces
- Provides device interrupt arbitration
- Spurious interrupt monitor

- Twelve programmable chip-select outputs
- Watchdog timer, clock monitor, and bus monitor
- PLL clock synthesizer

### Single-Chip Integration Module (SCIM)

- Manages controller internal and external bus interfaces
- Provides device interrupt arbitration
- Spurious interrupt monitor
- Single-chip operation with address and data bus pins configured as I/O ports
- Optional Fully or Partially-expanded bus operation
- Nine general-purpose chip select outputs
- Emulation mode chip-select outputs can be used to address a port replacement unit and external emulation RAM
- Watchdog timer, clock monitor, and bus monitor
- PLL clock synthesizer
- Interrupt request inputs can be configured for edge or level detection
- Reduced pin SCIM (RPSCIM) available with 5 chip selects

2

## Timers

### Time Processor Unit (TPU)

- On-chip microengine dedicated to high-speed timing tasks
- Two independent 16-bit counters used as basis for timing tasks
- Real-time task scheduler
- Executes a programmed series of functions to perform complex tasks
- Each of 16 orthogonal channels can perform available time functions
- Functions contained in dedicated control store or in MCU RAM
- TPU communicates to CPU via dual port RAM

### General Purpose Timer (GPT)

- Two 16-bit free-running counters
- Three input capture channels
- Four output compare channels
- One input capture/output compare channel
- One pulse accumulator/event counter input
- Two pulse-width modulation outputs
- Pulse accumulator input

### Configurable Timer Module (CTM)

- Modular timer system combining different configurations of timer submodules:
- CPSM-6 TAP counter prescaler
- FCSM-16-bit free running up counter
- MCSM-16-bit modulus up counter
- SASM-(Single Action) two I/O pins for 16-bit input capture or output compare functions
- DASM-(Dual Action) one I/O pin for 16-bit I/C, O/C, PWM, or output function

## Timer Module (TM)

- 16-bit free-running counter with 8-bit prescaler
- Two TM can be externally cascaded to increase count width
- Software selected input capture, output compare, pulse accumulation, event counting, or pulse-width modulation functions

## Communication Modules

### Queued Serial Module (QSM)

- Queued full-duplex, synchronous three-line SPI with dedicated RAM
- Standard, asynchronous NRZ-format SCI
- Polled and interrupt-driven operation
- Pins can be configured as a parallel I/O port

### Multi-Channel Communications Interface (MCCI)

- One full-duplex synchronous three-line SPI
- Two independent standard, asynchronous NRZ-format SCI
- Polled and interrupt-driven operation
- Pins can be configured as a parallel I/O port

### Dual Universal Asynchronous/Synchronous Receiver Transmitter (DUART)

- Dual NRZ Serial RS-232C channels
- Independently programmable Tx and Receiver Transmitter (DUART)
- RxD Baud rates for each channel up to 76.8K Baud
- Optional external input pins provide baud clock
- Transmit operations are double buffered, and receive operations are quadruple buffered
- RTS and CTS signals are directly supported

## Analog-to-Digital Conversion Modules

### Analog-to-Digital Converter (ADC)

- 8 or 10 bits of resolution
- Eight input channels
- Eight result registers
- Three result alignment formats
- Eight automated conversion modes
- Programmable sample and hold times are provided
- Three result alignment modes

### Queued Analog-to-Digital Converter (QADC)

- 10 bits of resolution
- 16 analog input channels (up to 27 if multiplexed externally)
- Two independent conversion queues
- 32 result registers (16 per queue)
- Three result alignment formats

- Queued conversions can be performed continuously or can be retriggered by software or the QADC module periodic interval timer and external trigger
- Programmable sample and hold times
- Alternate voltage references

## Specialized Control Modules

### Direct Memory Access (DMA)

- Provides low-latency transfer to external peripheral or for memory-memory data transfer
- Two independent DMA channels with full programmability

## Memory Modules

### Standby RAM (SRAM)

- Fast Static RAM maintained by voltage from standby voltage pin
- Available in 1K, 1.5K, 2K, 3.5K, and 4K blocks
- Fast (2 clock) access speed
- Byte, word, and long-word operations supported

### Standby RAM with TPU Emulation (TPURAM)

- Fast Static RAM maintained by voltage from standby voltage pin
- Available in 1K, 1.5K, 2K, 3.5K, and 4K blocks
- Fast termination (2 clock) access speed
- Supports TPU microcode ROM emulation
- Byte, word, and long-word operations supported

### Masked ROM (MRM)

- Custom-masked non-volatile 16-bit wide memory
- Available in 4K increments from 8K to 48K bytes
- Fast (2 clock) access speed
- Byte, word, and long-word operations supported
- Boot ROM capability

### Flash EEPROM (FLASH)

- Word programmable, bulk erasable non-volatile 16-bit wide memory
- Available in 8K increments from 8K to 64K bytes
- Fast (2 clock) access speed
- Byte, word, and long-word operations supported
- Boot ROM capability
- External 12 volt programming/erasure source required

### Block Erasable Flash EEPROM (BEFLASH)

- Available in 8K increments from 8K to 64K bytes
- Eight independently-erasable blocks
- Fast termination (2 clock) access speed
- Byte, word, and long-word operations supported
- Byte/Word programming with 12 volt external input

# The M68HC16 Family

The M68HC16 family is designed for embedded control applications. Each M68HC16 MCU incorporates a true 16-bit CPU module (CPU16) that is upwardly code-compatible with the M68HC11 CPU, a sophisticated integration module, and a number of special-purpose modules. M68HC16 devices

can be placed in low-power stop mode to minimize power consumption during periods of inactivity. The M68HC16 family provides the flexibility and features of the M68300 family, and also provides a convenient way for users of M68HC11 devices to move up to 16-bit performance.

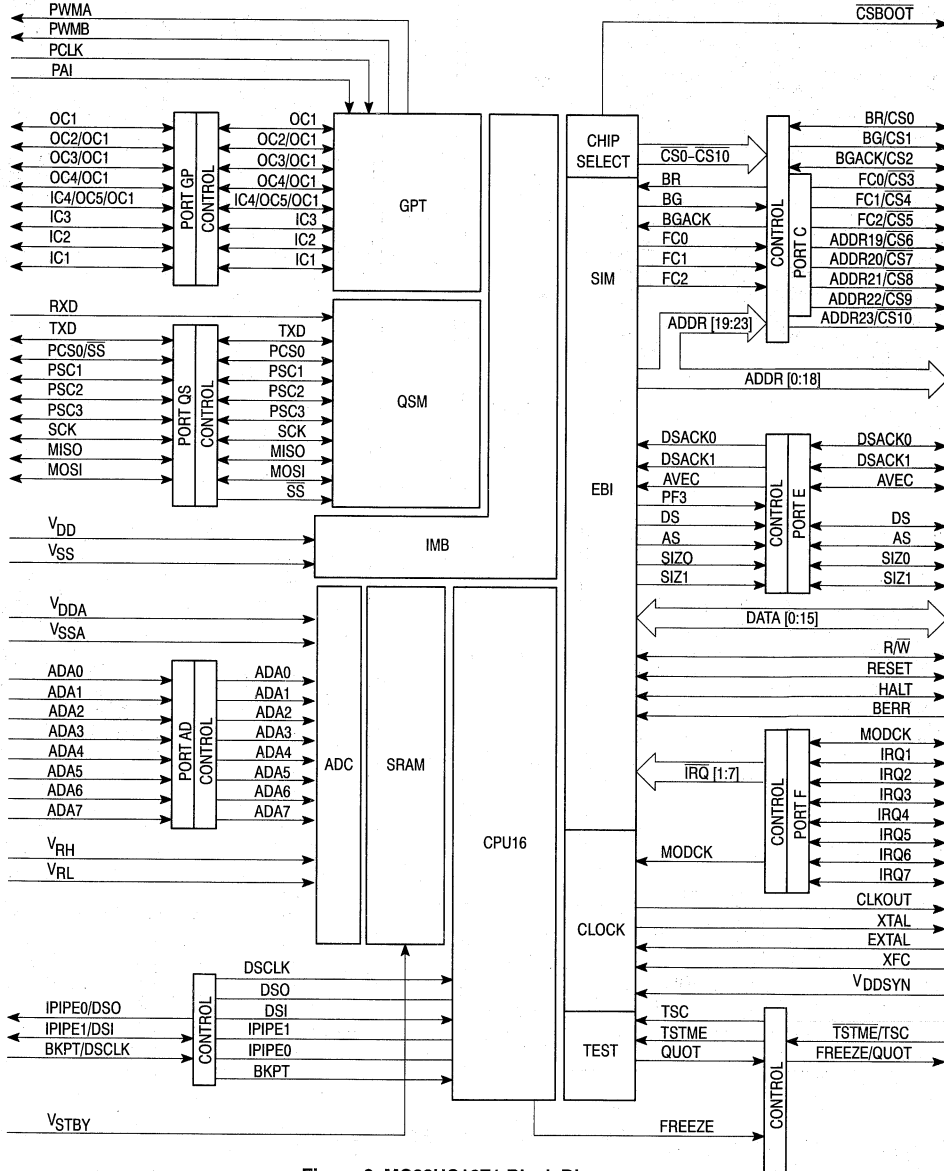

Figure 9. MC68HC16Z1 Block Diagram

2

2

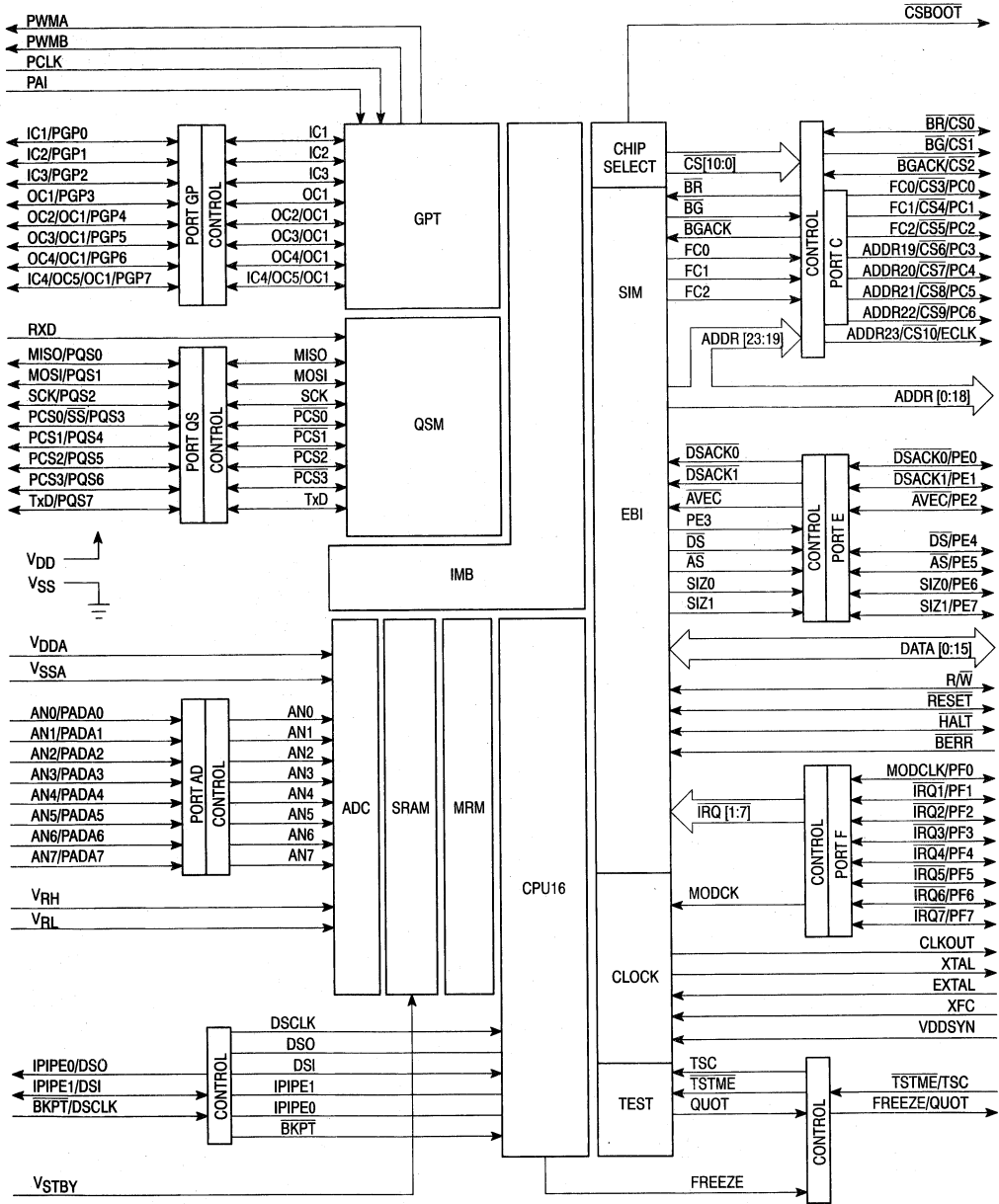
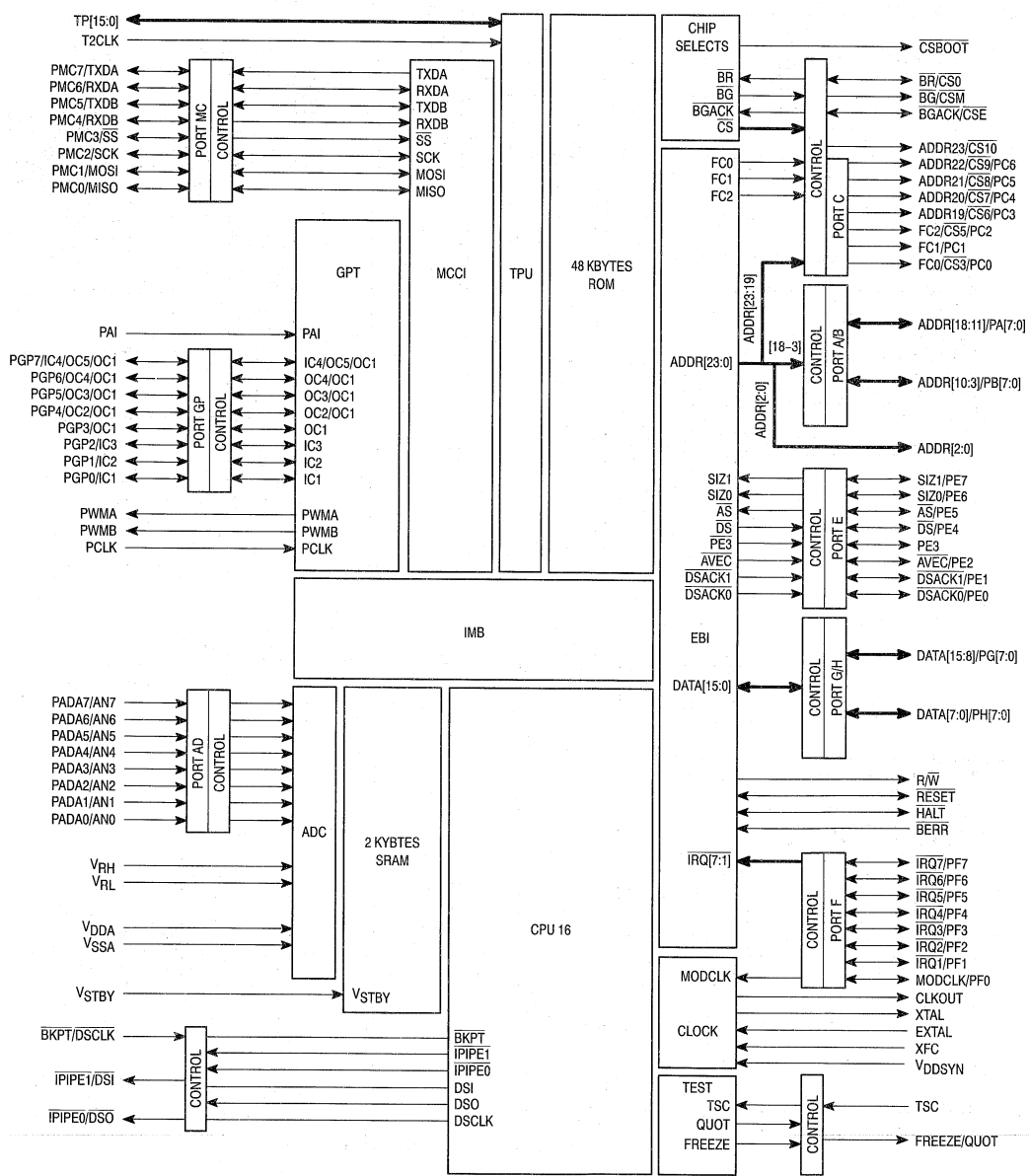

Figure 10. MC68HC16Z2 Block Diagram



2

Figure 11. MC68HC16Y1 Block Diagram



2

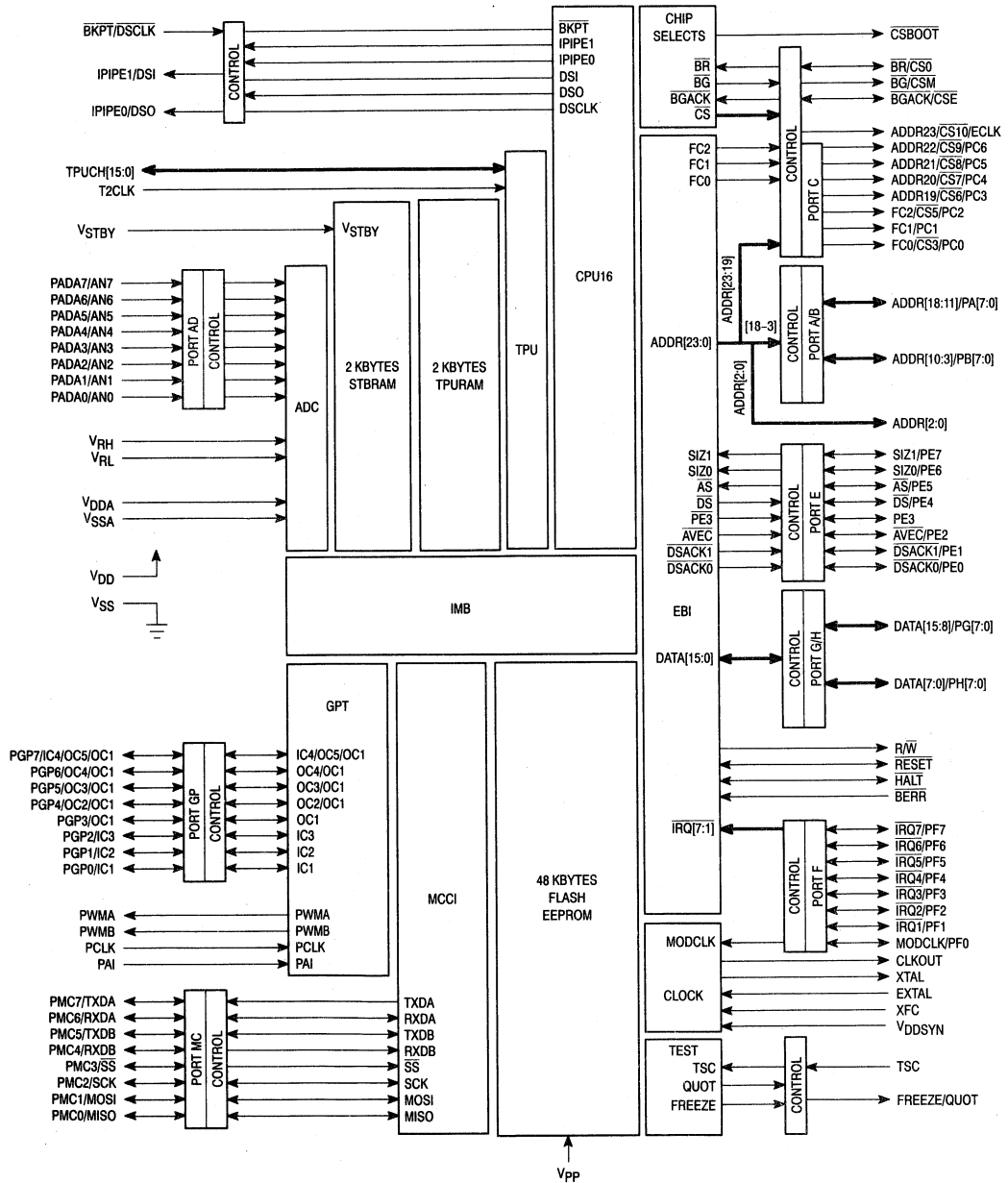

Figure 12. MC68HC916Y1 Block Diagram

**Table 9. M68HC16 Family Modular Microcontrollers**

Part Number	ROM	SRAM	EEPROM	Timer	I/O	Serial	ADC	Integration Module	Package	Comments
MC68HC16Z1	–	1K	–	GPT	46	QSM	8 Ch, 10-Bit	SIM	132-FC 132-FD 144-FM 144-FV	20 Address Lines, 12 Chip Selects, Synthesized Clock
MC68HC16Z2	8K	2K	–	GPT	46	QSM	8 Ch, 10-Bit	SIM	132-FC 132-FD	20 Address Lines, 12 Chip Selects, Synthesized Clock
MC68HC16Y1	48K	2K	–	TPU + GPT	95	MCCI	8 Ch, 10-Bit	SCIM	160-FT 160-FM	20 Address Lines, 9 Chip Selects, Single Chip or Expanded Mode
XC68HC916X1		1K	2K BEFlash 48K Flash	GPT	70	QSM	8 Ch, 10-Bit	RPSCIM	120-TH	20 Address Lines, 5 Chip Selects, Single Chip or Expanded Mode
XC68HC916Y1	–	4K	48K Flash	TPU + GPT	95	MCCI	8 Ch, 10-Bit	SCIM	160-FT 160-FM	20 Address Lines, 9 Chip Selects, Single Chip or Expanded Mode

**2**

# The M68300 Family

The high-performance M68300 family is designed for embedded control applications. Each M68300 MCU incorporates a 32-bit M68000-based CPU module (CPU32), a sophisticated integration module, and a number of dedicated special-purpose modules. In addition to utilizing a bus protocol similar to that of the M68020, the system integration module generates external bus-control signals for

M6800 devices, and provides a variety of programmable chip-select functions. M68300 devices can be placed in low-power stop mode to minimize power consumption during periods of inactivity. The M68300 family provides great design flexibility, performance, and compatibility with exiting hardware and software.

2

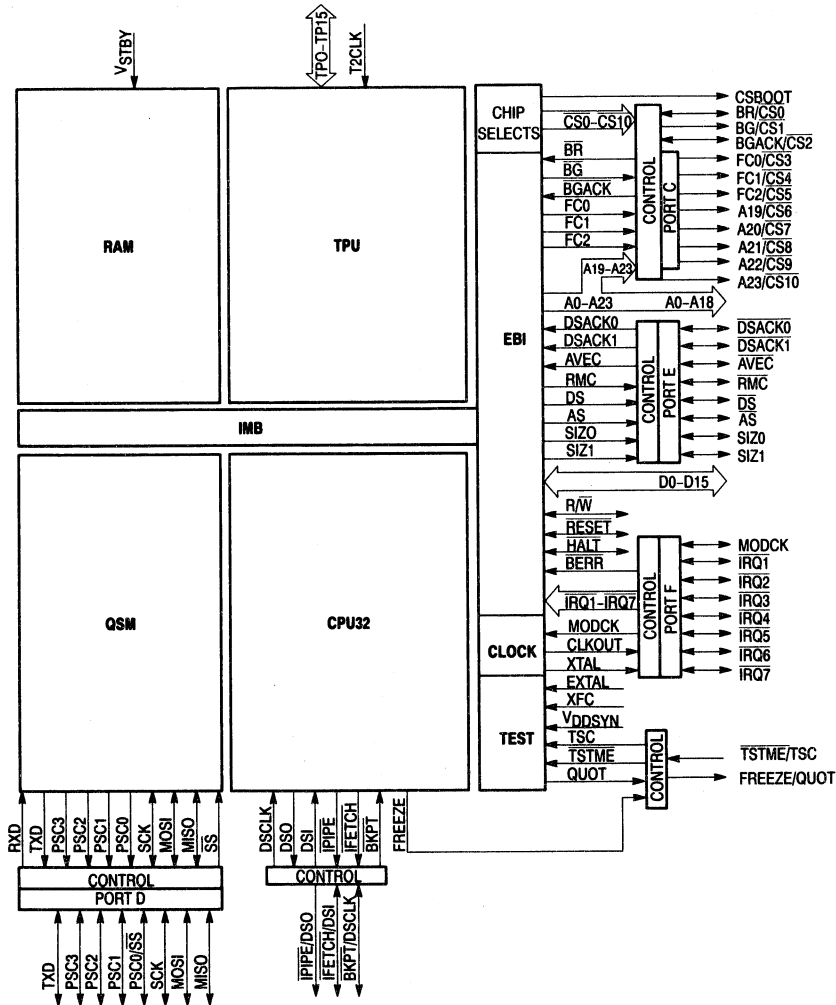

Figure 13. MC68332 Block Diagram

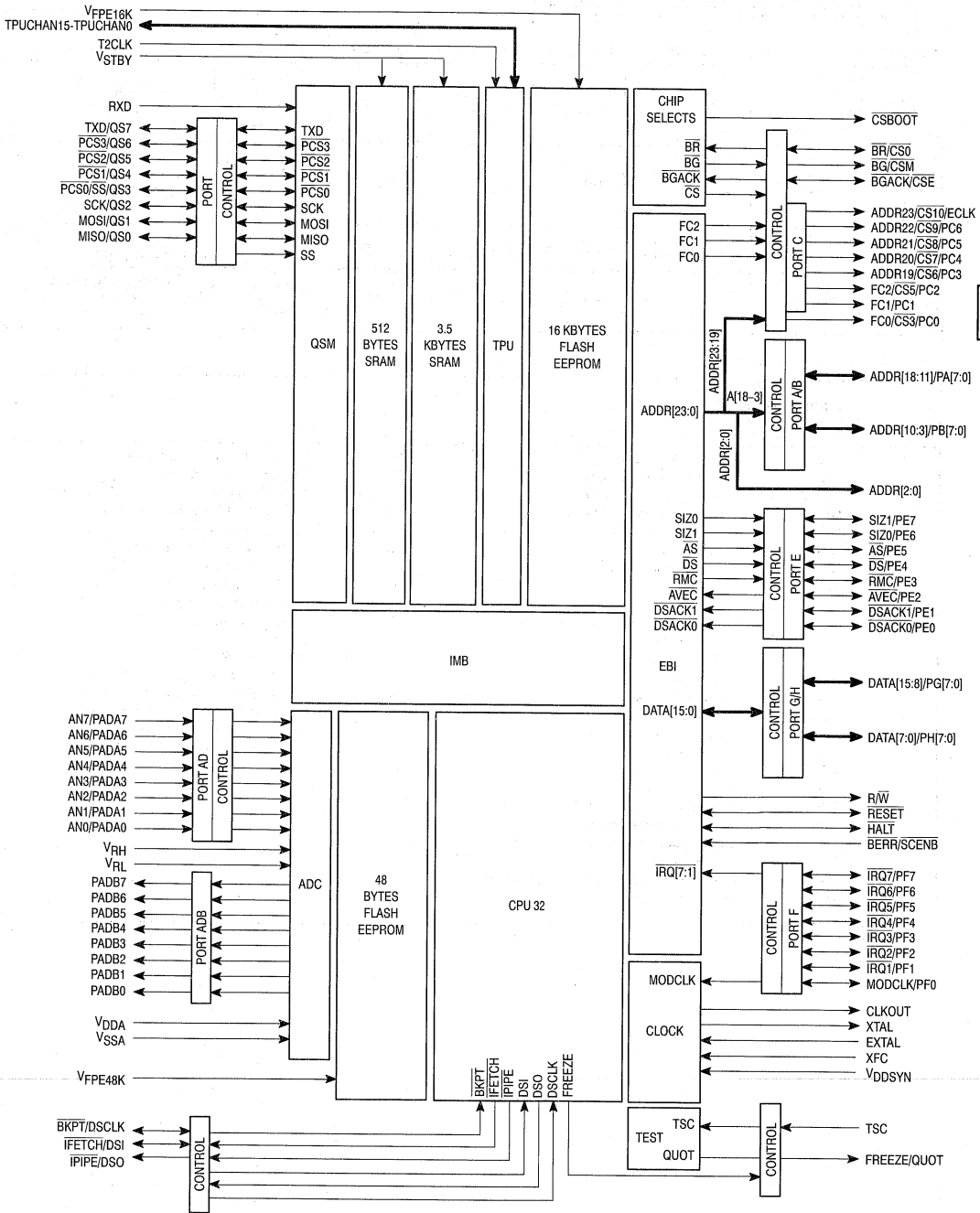

Figure 14. MC68F333 Block Diagram

**Table 10. M68300 Family Modular Microcontrollers**

Part Number	ROM	SRAM	EEPROM	Timer	I/O	Serial	ADC	Integration Module	Package	Comments
MC68331	-	-	-	GPT	43	QSM	-	SIM	132-FC, 132-FD, 144-FM, 144-FV	12 Chip Selects, Synthesized Clock
MC68332	-	2K	-	TPU	47	QSM	-	SIM	132-FC, 132-FD, 144-FM, 144-FV	12 Chip Selects, Synthesized Clock
PC68F333	-	4K	16K Flash, 48K Flash Emulator	TPU	96	QSM	8 Ch, 10-Bit	SCIM	160-FT, 160-FM	9 Chip Selects, Synthesized Clock
XC68334	-	1K	-	TPU	47	-	8 Ch, 10-Bit	SIM	132-FC, 132-FD	12 Chip Selects, Synthesized Clock, Single Chip or Expanded Mode

**2**

Definitions for Tables 9 and 10			
General Definitions		Package Definitions	
ADC	Analog to Digital Converter Module	FB	10x10 mm Quad Flat Pack (QFP)
A/D	Analog to Digital Converter	FC	Fine Pitch Plastic Quad Flat Pack (PQFP)
CPU16	16 bit Central Processing Unit	FD	Plastic Quad Flat Pack in Molded Carrier Ring
CPU32	32 bit Central Processing Unit	FE	Ceramic Quad Flat Pack (CQFP)
D/A	Digital to Analog Converter	FM	Molded Carrier Flat Pack (CQFP)
DMA	Direct Memory Access	FN	Plastic Leaded Chip Carrier (PLCC)
GPT	General-Purpose Timer	FS	Windowed Cerquad (Ceramic LCC)
IC	Input Capture	FT	28x28 mm Quad Flat Pack (QFP)
IIC	Inter-Integrated Circuit	FU	14x14 mm Quad Flat Pack (QFP)
MCCI	Multi-Channel Communication Interface	FV	20x20 mm Quad Flat Pack (QFP)
PLL	Phase Lock Loop	L	Ceramic
OC	Output Capture	P	Dual-in-Line Plastic
POQ	Preferred Order Quantity Multiple	PB	Thin Quad Flat Pack (TQFP) 10x10 mm
PWM	Pulse Width Modulation	PU	Thin Quad Flat Pack (TQFP) 14x14 mm
QSM	Queued Serial Module	PV	Thin Quad Flat Pack (TQFP) 20x20mm
RPSCIM	Reduced Pin Count SCIM	S	Cerdip (windowed or non-windowed)
RTC	Real-Time Clock	TH	16x16 mm Quad Flat Pack (QFP)
RTI	Real-Time Interrupt		
SCI	Serial Communication Interface		
SCIM	Single Chip Integration Module		
SIM	System Integration Module		
SPI	Serial Peripheral Interface		
TPU	Time Processing Unit		
UART	Universal Asynchronous Receiver/Transmitter		
WDOG	Watch Dog Timer		

# Microcontroller Development Tools

## M68HC05 Family

The M68HC05 Family is supported by a variety of development tools including Evaluation Modules (EVM) and Evaluation Systems (EVS). Both provide an economical means of designing, debugging, and evaluating M68HC05 microcontrollers in a target system environment.

Many new M68HC05 CSIC devices are supported by an MCU-specific EVS. The EVS is a two-board system consisting of a 68HC05 Platform Board (PFB) and an Emulator Module (EM) which contains the emulating microcontroller, and control circuits.

The M68HC05 Family is also supported by the Compact Development System (CDS) for 8-bit microcontrollers (M68CDS8HC05), a powerful, portable, full-featured emulator for debugging hardware and software operations. The CDS8HC05 features high-speed, non-invasive, in-circuit emulation with real-time trace, and a powerful bus state analyzer. Commands are entered from an MS-DOS® host computer.

The Motorola Modular Development System for the M68HC05 Family, MMDS05, allows the use of Emulation Modules (EM) that are compatible with the existing EVS product line. The MMDS05 provides an upgrade for CDS8HC05 customers. The MMDS05 has all of the features of the CDS8HC05, and includes a notable enhancement. A dual-port RAM "memory window" allows a user to modify memory while a program is running at full speed. An internal power supply and totally shielded enclosure assure compliance with FCC and EC92 regulations. The development software provided with the MMDS05 is an enhancement of the EVM05/EVM11 front end—it provides an integrated development environment with true Source Level Debug (SLD).

## M68HC11 Family

The M68HC11 Family is supported by a variety of economical development tools. These include Evaluation Boards (EVB), Evaluation Modules (EVM), and Evaluation Systems (EVS).

An EVB allows a user to debug code under the BUFFALO (Bit User Fast Friendly Aid to Logical Operations) monitor/debugging program contained in the microcontroller ROM. The EVB emulates only the single-chip mode of operation and has no EPROM programmer. The EVBU, a "universal" version of the EVB, includes a wire-wrap area for custom interfacing.

EVM are low-cost tools for designing, debugging, and evaluating M68HC11 devices in a target system. An EVM provides essential microcontroller signals and timing, and on-board monitor/debugging firmware contains extensive commands for controlling I/O and debug operations.

An EVS is a two-board system consisting of a 68HC11 Platform Board (PFB) and an Emulator Module (EM). The EM contains control circuits and a 68HC11 MCU for the part or series of parts being emulated. An EVS provides expanded, multiplexed, special test, and single-chip mode emulation, a dual 64 kbyte memory map with 64 kbytes of emulation RAM, and an RS-232 port.

In addition, the Intermetrics Whitesmiths 68HC11 C Compiler/Assembler (M68S11CCAB) and 68HC11 Simulator Debugger (M68S11SIMAB) are now available through Motorola.

## Modular Microcontroller Families

2

In-circuit debuggers for modular microcontroller families (M68ICD32 and M68ICD16) are economical development and debugging environments. ICD make use of the non-intrusive Background Debug Mode (BDM) interface, and provide sophisticated software debugging functions. The ICD consist of debugger and assembler development software, a small interconnect board, and target system cable. The IASM32 and IASM16 assemblers provide a single development environment that includes an editor and cross-assembler programs. ICD source-level debugger software uses easy-to-read screen windows to display register information for the CPU, the instruction pointer, breakpoints, program memory, and data memory.

The MC68331 and MC68332 are supported by evaluation kits (EVK). These multi-board systems include a common platform board, a Business Card Computer (BCC) that contains the MCU being emulated, and the CPU32BUG debug monitor program. The EVK is a cost-effective system for designing, debugging, and evaluating target system software and hardware. The MC68340 is supported by an evaluation system (EVS) similar to the EVK with the addition of a development interface board for a comprehensive development environment.

The M68HC16Z1 Evaluation Board (EVB) is an inexpensive tool for designing, debugging, and evaluating the MC68HC16Z1. Features include background-mode operation, an integrated assembly/editing/emulation environment, and logic analyzer pod connectors.

Modular evaluation boards (MEVB) for each modular family member are under development. The MEVB system is a multi-board evaluation system that consists of a common platform board (PFB) and interchangeable MCU personality boards (MPB). The MEVB system provides an economical development environment for downloading and debugging software generated with IASM16 and IASM32.

Motorola also sells the Intermetrics Whitesmiths 68HC16 C Compiler/Assembler (M68S16CCAB) and 68HC16 Simulator Debugger (M68S16SIMAB) for the M68HC16 Family. In addition, the Intermetrics InterTools™ 683XX C Compiler/Assembler (M68S32CCAB) and 683XX ROM Monitor Debugger (M68S32ROMAB) for the M68300 Family are now available through Motorola.

2

Table 11. Development Tools

Devices	Evaluation Modules*	Programmer Boards	Evaluation Systems/Kits
<b>M6800 Development Tools</b>			
MC6801		M68701EVM	
MC6801U4		M68701EVM	
MC68701		M68701EVM	
MC68701U4		M68701EVM	
MC6803		M68701EVM	
MC6803U4		M68701EVM	
<b>M68HC05 Development Tools</b>			
MC68HC05B4/B6/B8/B16 MC68HC705B5 MC68HC705B16	M68HC05X16EVS M68HC05X16EVS M68HC05X16EVS	M68HC05BPGMR M68HC05BPGMR	52PLCCU: 52 Pin PLCC Target Cable Use M68HC05X16PGMR for 64 QFP
MC68HC05C5 XC68HC705C5	M68HC05C5EVS M68HC05C5EVS		44 PLCC05M: 44 Pin PLCC Target Cable
MC68HC05C4/C4A/C8/C9/C12 XC68HC05C4 MC68HC705C8 XC68HC705C	M68HC05C9EVS M68HC05C9EVS	M68HC05PGMR-2	44 PLCC05M: 44 Pin PLCC Target Cable
MC68HC05D9/D24 XC68HC05D32 MC68HC705D9	M68HC05D32EVS M68HC05D32EVS	M68HC05PGMR-2	44 PLCC05M: 44 Pin PLCC Target Cable
MC68HC05E1 MC68HC705E1	M68HC05E1EVS M68HC05E1EVS		
XC68HC05F2 XC68HC05F6	M68HC05F6EVM		42 SDIP Target Cable Included
XC68HC05F8 XC68HC705F8	M68HC05F8EVM M68HC05F8EVM	M68HC705F8PGMR	
MC68HC05G1 MC68HC705G1	M68HC05G1EVM M68HC05G1EVM	M68HC705G1PGMR	
XC68HC05G9 XC68HC705G9	M68HC05G9EVM M68HC05G9EVM	M68HC705G9PGMR	
XC68HC05G10 XC68HC705G10	M68HC05G10EVM M68HC05G10EVM		
XC68HC05H2	M68HC05H2EVS		
XC68HC05I8 XC68HC705I8	M68HC05I8EVS M68HC05I8EVS	M68HC705L4PGMR	
MC68HC05J1 MC68HC705J2	M68HC05P8EVS M68HC05P8EVS	M68HC705J2PGMR	
XC68HC05J3 XC68HC705J3	M68HC05J3EVS M68HC05J3EVS	M68HC705J2PGMR	
XC68HC05K0/K1 XC68HC705K1		M68HC705KIGANG** Use M68HC705KICS	M68HC705KICS In-Circuit Simulator M68HC705KICS In-Circuit Simulator

\* EVSs and EVMs include an Integrated Development Environment (IDE) which contains an editor, assembler and hardware debugger.

\*\* EVSs and EVMs do not include target cables or OTP/EPROM programming capability unless noted in comment section.

\*\* Development tools that are scheduled for availability during 1Q94.

**Table 11. Development Tools (continued)**

Devices	Evaluation Modules*	Programmer Boards	Evaluation Systems/Kits
<b>M68HC05 Development Tools (continued)</b>			
XC68HC05L1 XC68HC705L1	M68HC05L1EVM M68HC05L1EVM		56 SDIP Target Cable Included
XC68HC05L2 XC68HC705L2	M68HC05L2EVS M68HC05L2EVS	M68HC705L2PGMR	
XC68HC05L4 XC68HC705L4	M68HC05L4EVS M68HC05L4EVS	M68HC705L4PGMR	M68SDIP64: 64 Pin SDIP Target Cable
MC68HC05L5 MC68HC705L5	M68HC05L5EVS M68HC05L5EVS	M68HC705L5PGMR	80QFPUKIT: 80 Pin QFP Target Cable
MC68HC05L7/L9	M68HC05L9EVM2		
MC68HC05L10	M68HC05L10EVM		
XC68HC05L11	M68HC05L11EVM		
XC68HC05M4	M68HC05M4EVM		
XC68HC05P3	M68HC05P3EVS		
MC68HC05P1/P4/P6/P7/P9 XC68HC705P9	M68HC05P9EVS M68HC05P9EVS	M68HC705P9PGMR	XMDS05 Hi-Performance In-Circuit Emulator 68HC705P6 is required for P6 EVS Capability
MC68HC05P8	M68HC05P8EVS		
XC68HC05SC11/SC21/SC24/SC27	M68HC05SCEVS		ISO Adaptor Included with M68HC05SCEVS
MC68HC05T1 XC68HC05T2/T3	M68HC05T2EVS		
XC68HC05T4	M68HC05T4EVM		
MC68HC05T7/T10 XC68HC705T10	M68HC05T7EVM M68HC05T7EVM	M68HC705T10PGMR	
XC68HC05T12 XC68HC705T12	M68HC05T12EVM M68HC05T12EVM	M68HC705T12PGMR	
XC68HC05X4 XC68HC705X4	M68HC05X4EVS M68HC05X4EVS	M68HC705X4PGMR	
XC68HC05X16 MC68HC705X16	M68HC05X16EVS M68HC05X16EVS	M68HC705X16PGMR	68 PLCCU: 68 Pin PLCC Target Cable
<b>M68HC11 Development Tools</b>			
MC68HC11A0/A1/A8	M68HC11EVB M68HC11EVB2 M68HC11EVBU	M68HC11EVM	
MC68HC11D0/D3		M68HC11EVM	M68HC11D3EVS
MC68HC711D3	M68HC711D3EVB	M68HC11EVM	M68HC11D3EVS
MC68HC11E0/E1/E2/E9	M68HC11EVB M68HC11EVBU	M68HC11EVM	
MC68HC711E9	M68HC11EVBU	M68HC11EVM	
MC68HC811A8/E2	M68HC11EVB M68HC11EVBU	M68HC11EVM	

\* EVSs and EVMs include an Integrated Development Environment (IDE) which contains an editor, assembler and hardware debugger.

\*\* EVSs and EVMs do not include target cables or OTP/EPROM programming capability unless noted in comment section.

\*\* Development tools that are scheduled for availability during 1Q94.

2



**Table 11. Development Tools (continued)**

Devices	Evaluation Modules*	Programmer Boards	Evaluation Systems/Kits
<b>M68HC11 Development Tools (continued)</b>			
MC68HC11F1			M68HC11F1EVS
MC68HC11G5/G7 MC68HC711G5			M68HC11G7EVS
MC68HC11KA4			M68HC11KA4EVS
MC68HC11K0/K1/K4 MC68HC711K4			M68HC11K4EVS
MC68HC11L0/L1/L6 MC68HC711L6			M68HC11L6EVS
MC68HC11M2 MC68HC711M2			M68HC11KMNPEVS
MC68HC11N4 MC68HC711N4			M68HC11KMNPEVS
MC68HC11P2 MC68HC711P2			M68HC11KMNPEVS
<b>M68HC16 Development Tools</b>			
MC68HC16Y1	MG8MEVB16Y1		
MC68HC16Z1	M68MEVB16Z1		
MC68HC16Z2	M68MEVB16Z1		
<b>M68300 Development Tools</b>			
MC68331	M68MEVB333		M68331EVK
MC68332	M68MEVB16Z1		M68332EVS/M68332EVK
MC68F333 MC6805R2/R3	M68MEVB333		

\* EVSs and EVMs include an Integrated Development Environment (IDE) which contains an editor, assembler and hardware debugger.

\* EVSs and EVMs do not include target cables or OTP/EPROM programming capability unless noted in comment section.

\*\* Development tools that are scheduled for availability during 1Q94.

2

# Fuzzy Logic

Fuzzy logic replaces conventional programming techniques with a simpler approach to control algorithms. Fuzzy logic uses a series of case statements to create sophisticated features that do not require additional memory or excessive processing time.

Motorola's portfolio of fuzzy logic products is geared for every level of user. The fuzzy logic educational kit (part number FLEDKT00) includes everything needed to learn how to use fuzzy logic with M68HC05 and M68HC11 microcontrollers.

- An easy-to-follow PC-based tutorial
  - Explains fuzzy logic fundamentals, basic concepts and terminology
  - Methodology section teaches a five-step sequence or principles and procedures for designing a fuzzy logic system. These include defining the control system, writing rules and membership functions, tuning and debugging and optimizing the design.
  - Advanced topics section covers areas such as stability, adaptability, ambiguity, noise, alpha-cuts and contribution weights
- A Knowledge Base Generator (KBG)
- Uses natural language inputs to generate a knowledge base (rules and membership functions)
- Inference Engines for the M68HC11 and M68HC05 families implement the fuzzy logic in software ready to embed in your Motorola microcontroller application

- Runs a software simulation of the inference engine and displays a two-dimensional plot of the control surface
- Generates real-time code for the standard M68HC05 or M68HC11 microcontroller families which can be downloaded to an evaluation module (EVM) for in-circuit emulation
- Demonstration-version of Apronix's Fuzzy Inference Development Environment (FIDE) software
- Features powerful, time-saving debug functions to help determine the correct membership functions and rules for any application
- Demonstrates easy-to-use graphical interface for designing and debugging integrated systems

2

Apronix's Fuzzy Inference Development Environment (FIDE™) is a powerful software tool that allows users to easily edit, simulate, debug, and tune the membership functions and rules of a fuzzy logic application. FIDE offers graphical and natural language editing of source files. The user-friendly debug tools allow time domain simulations, three-dimensional surface displays of input-to-output relationships, and linkage of fuzzy and non-fuzzy modules. FIDE also generates assembler code that implements fuzzy logic on Motorola microcontrollers.

## On-Line Help

### Microcontroller Electronic Bulletin Board

Freeware Data Service provides a direct line to the latest information and software for Motorola microcontrollers. The Freeware bulletin board provides access to:

- Development Software for PC and Macintosh Computers
  - Cross Assemblers
  - Small C Compiler for 68HC11
  - EVM and EVB Monitor/Debugger Object Code
- Development software
  - Floating Point Routines
  - Fast Fourier Transform Routines
  - 16-Bit Math Packages
  - Utility Programs
  - User Group Library Routines and User-Donated Programs
- Kermit File Transfer Program
- Terminal Emulation Program
- Masked ROM information
- MCU literature listings
- Updates/Erratas to existing literature

- Press releases and updates concerning new and phase-out products
- Contests, promotions and seminars
- Electronic mail service

### How to Access Freeware

You can access Freeware from anywhere in the world. To log on, you'll need the following equipment:

1. 2400/1200/300 baud modem
2. Terminal, MS-DOS personal computer or Macintosh computer
3. Telephone line

This equipment will allow the user to read files and post questions. However, with a file transfer program such as XMODEM, YMODEM or Kermit, all information can be downloaded to your terminal or PC.

To log on:

1. Dial (512) 891-FREE (891-3733). Be sure to set the character format to 8 data, no parity, 1 stop bit.
2. Follow directions from the system.
3. Read log-on messages, then follow the directions on the screen display. A log-on session is limited to 120 minutes.

# Third-Party Support

Development support for Motorola microcontrollers is available from a variety of independent suppliers.

## Third-Party Development Tools

**Table 12. Software Products**

M68HC05 Family	M68HC11 Family	M68HC16 Family	M68300 Family
<b>Simulators</b>			
Byte Craft Ltd. P&E Microcomputer Systems, Inc. PseudoCorp. TECi	Avocet Systems, Inc. Nohau Corp. P&E Microcomputer Systems, Inc.	P&E Microcomputer Systems, Inc.	Software Environments Ltd.
<b>Assemblers</b>			
2500AD Software, Inc. American Arium Byte Craft Ltd. Computer Systems Consultants, Inc. Eris Systems, Inc. Introl Corp. Lloyd I/O, Inc. LOGISOFT Micro Dialects, Inc. Onset Computer Corp. P&E Microcomputer Systems, Inc. PseudoCorp. TECi	2500AD Software, Inc. Archimedes Software, Inc. Avocet Systems, Inc. Computer Systems Consultants, Inc. Eris Systems, Inc. Introl Corp. Lloyd I/O, Inc. LOGISOFT Micro Dialects, Inc.	2500AD Software, Inc. Byte Craft Ltd. Eris Systems, Inc. Introl Corp. Micro Dialects, Inc. P&E Microcomputer Systems, Inc.	Avocet Systems, Inc. Eyring Systems Software Division Introl Corp. Micro Dialects, Inc. Microtec Research, Inc. Oasys, Inc.
<b>Symbolic Debuggers</b>			
2500AD Software, Inc. Byte Craft Ltd. P&E Microcomputer Systems, Inc. TECi Wytec Company	2500AD Software, Inc. Microtec Research, Inc. P&E Microcomputer Systems, Inc. TECi	Byte Craft Ltd.	Eyring Systems Software Division Integrated Systems, Inc. JMI Software Consultants, Inc.
<b>Compilers</b>			
American Arium Byte Craft Ltd.	2500AD Software, Inc. Archimedes Software, Inc. Avocet Systems, Inc. Forth, Inc. Intermetrics Microsystems Software, Inc. Introl Corp. Laboratory Microsystems Inc. New Micros, Inc. Software Environments Ltd. SYNGEN Industrial Control	Byte Craft Ltd. Intermetrics Microsystems Software, Inc. Introl Corp. Software Environments Ltd.	Eyring Systems Software Division Forth, Inc. Integrated Systems, Inc. Intermetrics Microsystems Software, Inc. Introl Corp. Laboratory Microsystems Inc. Microtec Research, Inc. Microware Systems Corp. RAVEN Computer Systems Sierra Systems

2

**Table 12. Software Products (continued)**

M68HC05 Family	M68HC11 Family	M68HC16 Family	M68300 Family
<b>Source Level Debuggers</b>			
Byte Craft Ltd.  Yokogawa Digital Computer Corp.         Introl Corp.	Huntsville Microsystems, Inc. Intermetrics Microsystems Software, Inc. Introl Corp. Yokogawa Digital Computer Corp.	Huntsville Microsystems, Inc. Intermetrics Microsystems Software, Inc. Introl Corp. Yokogawa Digital Computer Corp.	Embedded Support Tools Corp. Eyring Systems Software Division GreenSpring Computers, Inc. Huntsville Microsystems, Inc. Integrated Systems, Inc. Intermetrics Microsystems Software, Inc.  Microtec Research, Inc. Sierra Systems Yokogawa Digital Computer Corp.
<b>Real-Time Executives</b>			
	Accelerated Technology, Inc. A. T. Barrett & Associates U S Software Corporation	A. T. Barrett & Associates U S Software Corporation	Accelerated Technology, Inc. A. T. Barrett & Associates Eyring Systems Software Division GreenSpring Computers, Inc. Integrated Systems, Inc. JMI Software Consultants, Inc. Microware Systems Corp. Ready Systems U S Software Corporation
<b>Other</b>			
PsuedoCorp	Logic Automation Inc. LOGISOFT PsuedoCorp U S Software Corporation	Momentum Data Systems, Inc. U S Software Corporation	Avocet Systems, Inc. CARDtools Systems Corp. Eyring Systems Software Division GreenSpring Computers, Inc. Integrated Systems, Inc. JMI Software Consultants, Inc. Logic Automation Inc. Microware Systems Corp. U S Software Corporation

2

**Table 13. Hardware Products**

M68HC05 Family	M68HC11 Family	M68HC16 Family	M68300 Family
<b>Logic Analyzers</b>			
	American Arium Hewlett-Packard Step Engineering Tektronix, Inc.	Hewlett-Packard Tektronix, Inc.	Hewlett-Packard
<b>Emulators</b>			
American Arium  Orion Instruments, Inc. Pentica Systems Inc. Sophia Systems & Technology TECi Thorson Engineering Co. Trace Technology Ltd. Yokogawa Digital Computer Corp.	Advance Electronic Diagnostics, Inc.  American Arium Huntsville Microsystems, Inc. MetaLink Corp. Nohau Corp. Orion Instruments, Inc. Pentica Systems Inc. Sophia Systems & Technology TECi Thorson Engineering Co. Wytec Company Yokogawa Digital Computer Corp.	Embedded Support Tools Corp.  Huntsville Microsystems, Inc. Nohau Corp. Pentica Systems, Inc. Yokogawa Digital Computer Corp.	Advance Electronic Diagnostics, Inc. Applied Microsystems Embedded Support Tools Corp. Hewlett-Packard Huntsville Microsystems, Inc. Microtek International Nohau Corp. Pentica Systems Inc. Yokogawa Digital Computer Corp.
<b>Evaluation Boards</b>			
Elan Digital Systems	Elan Digital Systems Mosaic Industries, Inc. New Micros, Inc.	New Micros, Inc.	GreenSpring Computers, Inc. New Micros, Inc.
<b>Other</b>			
3M Electronic Products Division AMP Inc. EE Tools Co. Elan Digital Systems Pentica Systems Inc. TECi	3M Electronic Products Division AMP Inc. Elan Digital Systems Emulation Technology, Inc. Pentica Systems Inc. SYNGEN Industrial Control	AMP Inc. P&E Microcomputer Systems, Inc.	Emulation Technology, Inc Pentica Systems Inc.

2

**Table 14. Contact List**

Company	Phone
3M Electronic Products Division	(512) 984-3441
2500AD Software, Inc.	(719) 395-8683
A. T. Barrett & Associates	(713) 728-9688
Accelerated Technology, Inc.	(205) 450-0707
Advance Electronic Diagnostics, Inc.	(602) 861-9359
American Arium	(714) 731-1661
AMP Inc.	(800) 52AMP52
Applied Microsystems	(800) 426-3925
Archimedes Software, Inc.	(415) 567-4010
Avocet Systems, Inc.	(800) 448-8500
Byte Craft Ltd.	(519) 888-6911
CARDtools Systems Corp.	(408) 559-4240
Computer Systems Consultants, Inc	(404) 483-4570
EE Tools Co.	(716) 346-6973
Elan Digital Systems	(4489) 579799
Embedded Support Tools Corp.	(617) 828-5588
Emulation Technology, Inc.	(408) 982-0660
Eris Systems, Inc.	(612) 374-2967
Eyring Systems Software Division	(801) 375-2434
Forth, Inc.	(213) 372-8493
GreenSpring Computers, Inc.	(415) 327-1200
Hewlett-Packard	(800) 447-3282
Huntsville Microsystems, Inc.	(205) 881-6005
Integrated Systems, Inc.	(408) 980-1500
Intermetrics Microsystems Software, Inc.	(617) 661-0072
Introl Corp.	(414) 327-7171
JMI Software Consultants, Inc.	(215) 628-0840
Laboratory Microsystems Inc.	(310) 306-7412
Lloyd I/O, Inc.	(503) 222-0702
Logic Automation Inc.	(503) 690-6900
LOGISOFT	(408) 773-8465
MetaLink Corp.	(602) 926-0797
Micro Dialects, Inc.	(513) 271-9100
Microtec Research, Inc.	(408) 980-1300
Microtek International	(503) 645-7333
Microware Systems Corp.	(515) 224-1929
Momentum Data Systems, Inc.	(714) 577-6894
Mosaic Industries, Inc.	(415) 790-1255
New Micros, Inc.	(214) 339-2204
Nohau Corp.	(408) 866-1820
Oasys, Inc.	(617) 862-2002

2

**Table 14. Contact List (continued)**

Company	Phone
Onset Computer Corp.	(508) 563-9000
Orion Instruments, Inc.	(800) 729-7700
P&E Microcomputer Systems, Inc.	(617) 944-7585
Pentica Systems Inc.	(617) 275-4419
PseudoCorp.	(804) 873-1947
RAVEN Computer Systems	(612) 636-0365
Ready Systems	(800) 228-1249
Sierra Systems	(510) 339-8200
Software Environments Ltd.	(714) 588-9685
Sophia Systems & Technology	(800) 824-9294
Step Engineering	(408) 733-7837
SYNGEN Industrial Control	(403) 986-1203
TECi	(802) 525-3458
Tektronix, Inc.	(503) 629-1773
Thorson Engineering Co.	(206) 334-4214
Trace Technology Ltd.	0234 266 455
U S Software Corporation	(503) 641-8446
Wytec Company	(708) 894-1440
Yokogawa Digital Computer Corp.	(415) 570-7050

**2**

# LONWORKS™ Products

---

## In Brief . . .

Motorola's NEURON® CHIP distributed communication and control processors are sophisticated VLSI devices that make it possible to implement low-cost Local Operating Network applications. The unique combination of hardware and firmware provides all the key functions necessary to process inputs from sensors and control devices intelligently, and propagate control information across a variety of network media.

Used in conjunction with the LONBUILDER™ developer's workbench, the NEURON CHIPS make available to a system designer an object-oriented, high-level environment providing for the easy implementation of distributed sense and control networks, flexible reconfiguration capability after network installation, and management of LONTALK™ protocol messages on the network.

Applications include distributed sense and control systems, instrumentation, machine automation, processor control, diagnostic equipment, environmental monitoring and control, power distribution and control, production control, lighting control, building automation and control, security systems, data collection/acquisition, robotics, home automation, consumer electronics, and automotive electronics.

	<b>Page</b>
NEURON CHIPS . . . . .	2.6-2
LONWORKS Technology Overview and Architecture . . . . .	2.6-4
LONBUILDER Developer's Workbench . . . . .	2.6-5
LONWORKS Support Tools . . . . .	2.6-6
LONWORKS Literature . . . . .	2.6-7



# NEURON CHIPS

Motorola's NEURON CHIPS, the MC143120 and MC143150, are the brains behind LONWORKS technology. These VLSI devices are specifically designed for distributed systems where sensing, processing, control, and communication are paramount. With LONWORKS development tools and software, they form a complete system solution that provides easy development of Local Operating Networks.

The power of both chips lies in their three respective on-board CPU's, high-speed serial communications ports (up to 1.25 MBps), and LONTALK communications protocol which is based on the OSI reference model. The difference between the two integrated circuits lies in the type and size of memory configuration; the MC143120 is targeted for cost-sensitive designs with small application programs; the

MC143150 is for larger systems with expanded software requirements.

## MC143120 Features

The MC143120 is a complete system-on-a-chip that integrates 10K ROM, 1K RAM, and 512 bytes EEPROM. The ROM is used for storing LONTALK protocol, operating system, and 24 I/O functions that can be accessed by the application program. Application program data is stored in RAM or the internal EEPROM. The application program and system configuration data reside in the MC143120's internal EEPROM. The MC143120 is available in a 32-pin SOG.

2

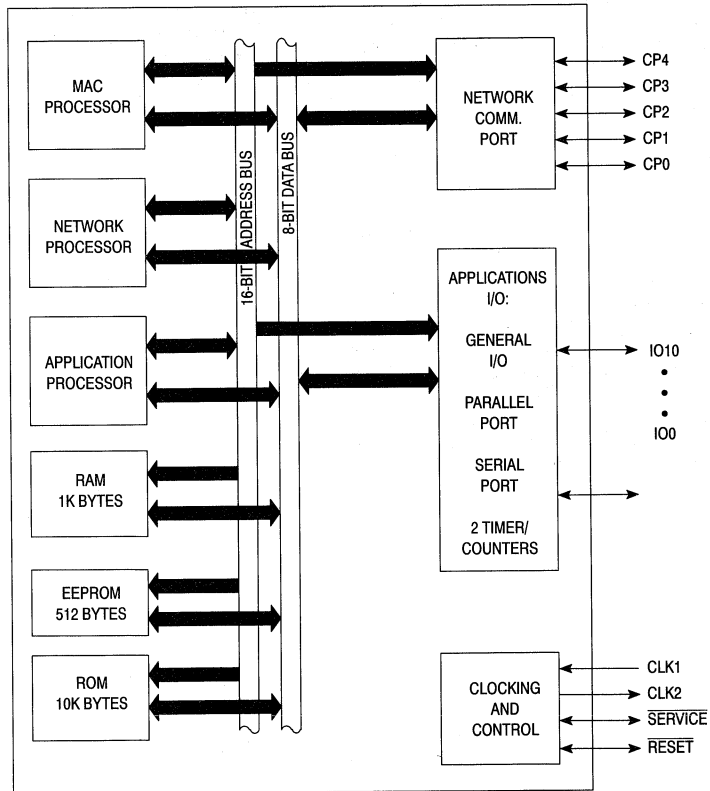

Figure 15. MC143120DW (32-LEAD SOG)

## NEURON CHIPS (continued)

### MC143150 Features

The MC143150 contains an additional 1K of on-chip RAM but no on-board ROM. An external memory interface allows the system designer to use 42K of the available 64K of address space for application program storage. The remaining address space is reserved for LONTALK communications protocol, operation system, and up to 24 I/O functions which are supplied with the LONBUILDER Developer's Workbench. The protocol and application code can be located in external ROM, EEPROM, NVRAM, or battery-backup static RAM. The MC143150 is available in a 64-pin QFP.

### Shared Strengths

Of the three processors on-board each NEURON CHIP, two implement a communication subsystem, enabling the automatic transfer of information from node to node. The remaining processor handles the application program. The NEURON IC supports a maximum clock rate of 10 MHz.

Both NEURON CHIPS have eleven I/O pins (IO.0 — IO.10) to provide flexible interfacing to external hardware and access to two internal timers/counters. All eleven I/O (IO.4 — IO.7) have optional pull-up resistors. Pins IO.0 — IO.3 have high current sink capability (20 mA @ 0.8 V) while others have a standard sink capability of 1.4 mA @ 0.4 V. All I/O pins have TTL-level inputs with hysteresis.

There are two versions of the MC143150 NEURON IC that offer different cost and technical advantages. The MC143150FU operates up to a maximum clock rate of 10 MHz over a temperature range of -40 to +85°C. The MC143150FU1 is a lower cost device that operates up to 5 MHz over the same temperature range and consumes less power. The key difference between the two IC's is in the cost saving gained by using an external 200 ns EPROM memory device with the mc 143150FU1 as opposed to a 90 ns memory device for a 10 MHz clock rate with the MC143150FU.

2

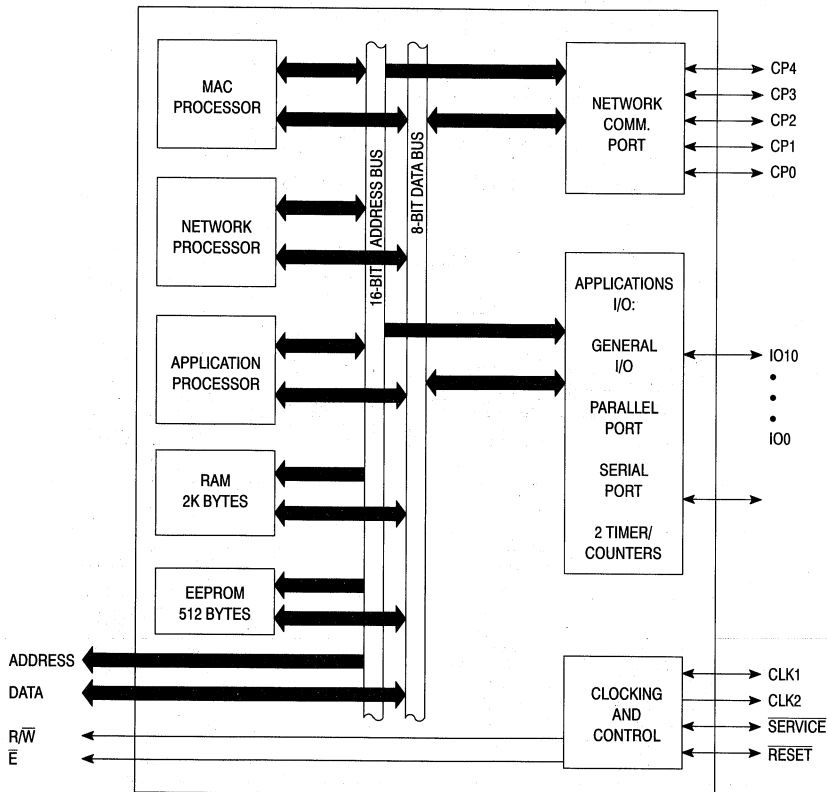

Figure 16. MC143150FU (64-LEAD PQFP)

# LONWORKS Technology Overview and Architecture

LONWORKS technology is a complete solution for implementing distributed control networks. These networks consist of nodes that communicate with one another over a variety of communications media using LONTALK protocol, a common, message-based communications protocol. In a LONWORKS application, nodes sense, monitor, count, measure time, manage switches and relays, and respond to conditions reported by other smart nodes.

LONWORKS technology includes all of the hardware and firmware functions needed to process data within nodes and to communicate information among nodes through a variety

of network physical layers. In one convenient package, designers can now access all the elements required to design, install, and support control networks. Those elements include: the MC143150 and MC143120 NEURON CHIPS, LONWORKS transceivers, the LONBUILDER Developer's Workbench and LONTALK protocol.

LONTALK protocol features seven layers, each optimized for control networks, and is based on the OSI reference model. LONTALK protocol is embedded within the firmware of Motorola's NEURON CHIPS and is the foundation of the LONWORKS technology networking solution.

2

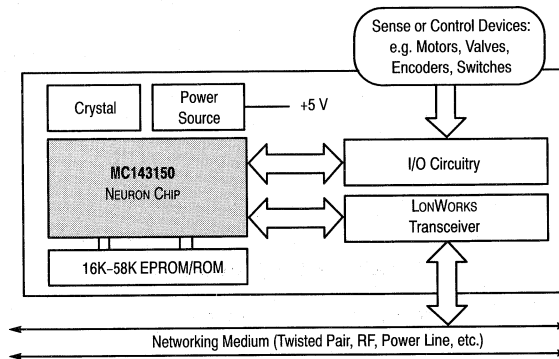

Figure 17. MC143150 in a Typical Node Block Diagram

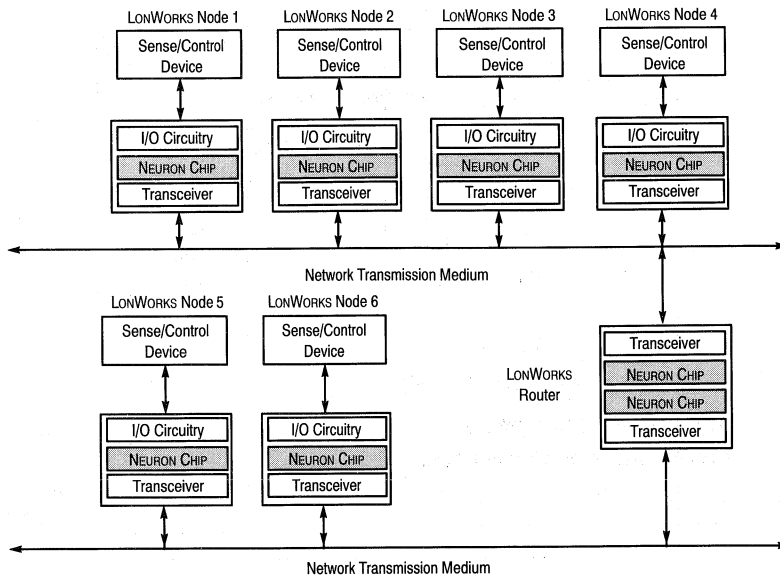

Figure 18. The MC143150 or MC143120 in a LONWORKS Network

## LONBUILDER Developer's Workbench (See Note 1)

This integrated hardware and software environment provides the tools necessary to build a Local Operating Network (LON®). LONWORKS consist of intelligent nodes that interact with their environment, and communicate with one another over a variety of communications media using a

common, message-based control protocol. Each node contains sufficient computing resources to implement the protocol and perform the node's control function. In addition, each node includes a transceiver that couples the node to the communications media.

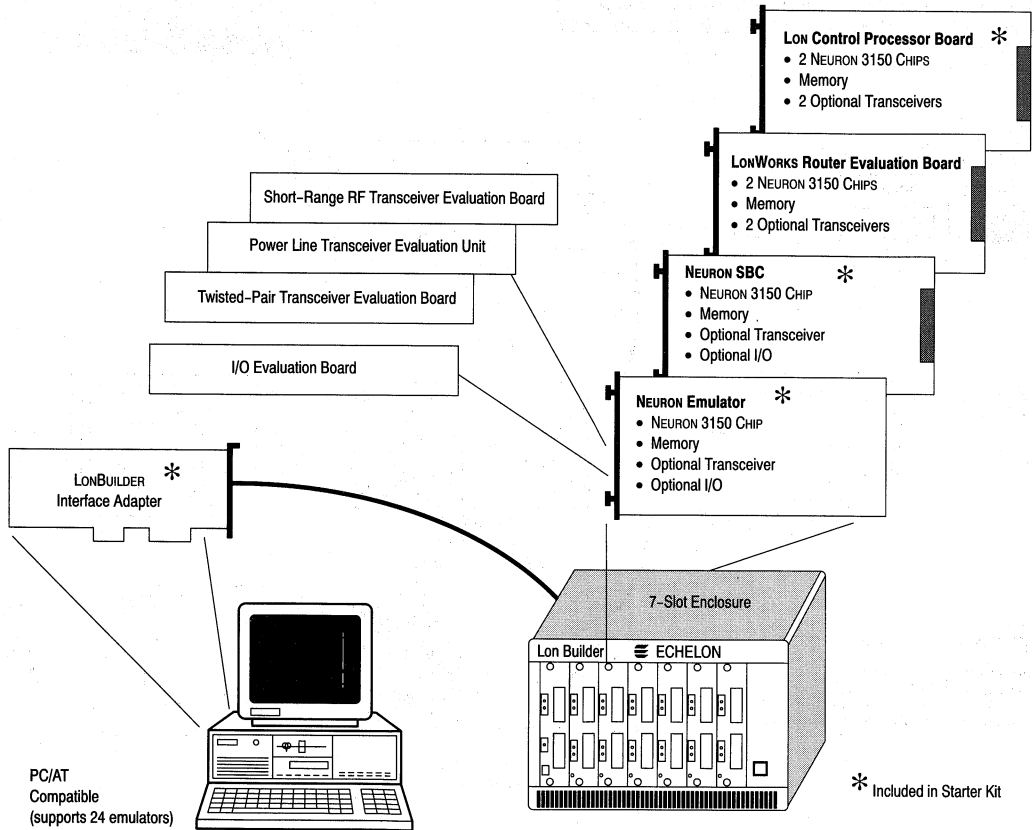

Figure 19. LONBUILDER Developer's Workbench and Starter Kit

### LONBUILDER Starter Kit (See Note 1)

The LONBUILDER Starter Kit contains all the tools necessary to begin LONWORKS development on a PC/AT or compatible computer. The starter kit contains a LONBUILDER Development Station (7-slot enclosure and PC interface adapter board) and the Interactive Development Environment Software consisting of

the Network Management Tools and the NEURON C Developer's Kit. The starter kit also contains two LONBUILDER NEURON CHIP Emulators. The backplane built into the enclosure can be used as an internal development network or optional LONBUILDER transceiver evaluation boards are available for external powerline, radio frequency, and twisted pair networks.

(1) Motorola supports these tools, but they should be purchased through Echelon Corporation (1-800-258-4566).

# LonWorks Support Tools

Motorola's LONBUILDER support tools offer the user a quick and flexible means to demonstrate or test a LONWORKS based product which was developed and debugged on the LONBUILDER Developer's Workbench. The family of tools consist of NEURON CHIP based development boards, I/O application boards, a Differential Direct Connect Transceiver Board (for the LONBUILDER Developer's Workbench), and a

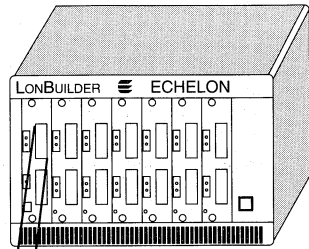

2

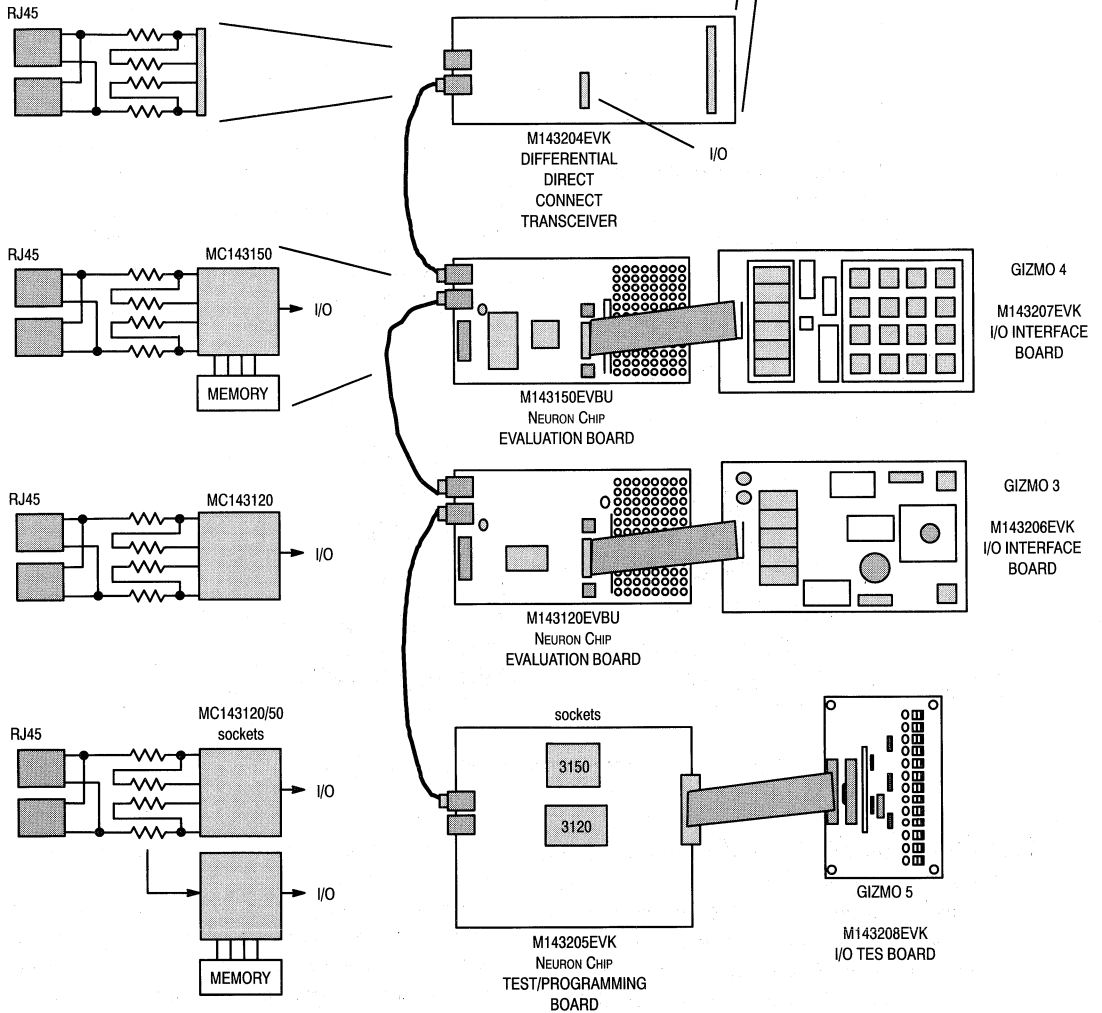

Figure 20. Evaluation and I/O Interface Boards

NEURON CHIP Test/Programming Board. The unique advantages that these tools offer are:

- The boards all have RJ45 connectors allowing ease of connectivity.
- The NEURON CHIP boards contain a 5 volt regulator allowing for a wider range of power supply voltages.
- A common 2 x 10 connector for interface to the NEURON CHIP I/O pins.
- A library of application functions are available from Motorola.
- An inexpensive means of demonstrating LONWORKS based products.

This document covers a brief detail on each of the boards. For further information, contact Motorola's LONWORKS applications support team in Austin, Texas at 512-505-8330 or FAX 512-505-8312.

The family consists of:

- M143120EVBU: MC143120DW NEURON CHIP Custom Node Development Board
- M143150EVBU: MC143150FU NEURON CHIP Custom Node Development Board
- M143204EVK: Direct Connect Transceiver Board
- M143205EVK: NEURON CHIP Test/Programming Board
- M143206EVK: NEURON CHIP I/O Interface Board (Gizmo 3)
- M143207EVK: NEURON CHIPN I/O Interface Board (Gizmo 4)
- M143208EVK: NEURON CHIP I/O Interface Test Board (Gizmo 5)

All the boards are available from Motorola and our franchised distributors.

2

## LONWORKS Literature

Motorola Document Number	Echelon Number	Description
<b>Data Sheets</b>		
MC143150/D		MC143150/20 NEURON IC Data Sheet
LONKITSUM/D	003-0001-01	MC143160EVK LONBUILDER Starter Tools
LONBDSUM/D	003-0003-01	MC143165/66/67EVK LONBUILDER Processor Boards Summary
LONTP/D	003-0004-01	MC143175 LONBUILDER Twisted Pair Transceiver
<b>Manuals</b>		
LONUG/AD	078-0001-01A	LONWORKS User's Guide
NEURONCPG/AD	078-0002-01A	NEURON C Programming Guide
<b>Application Notes</b>		
AN1208		Parallel I/O Interface
AN1211		Interfacing DAC's and ADC's to the NEURON IC
AN1216		Setback Thermostat Design using the NEURON IC
AN1225		Fuzzy Logic
EB146/D	005-0003-01	NEURON CHIP Quadrature Input Function Interface
EB147/D	005-0006-01	LONWORKS Installation Overview
EB148/D	005-0001-01	Enhanced Media Access with LONTALK Protocol
EB149/D	005-0011-01	Optimizing LONTALK Response Time
EB150/D	005-0009-01	NEURON CHIP RS-485 Transceiver
EB151/D	005-0004-01	Scanning a Keyboard with a NEURON CHIP
EB152/D	005-0002-01	How to Use SNVT's in LONWORKS Applications
EB153/D	005-0014-01	Driving a Seven Segment Display with the NEURON CHIP
EB155/D	005-0019-01	Analog-to-Digital Conversion with the NEURON CHIP
EB157/D	005-0016-01	Creating Applications with the LONBUILDER Multi-Function I/O Kit
EB159/D	005-0022-01	NEURON CHIP based Installation of LONWORKS Networks
EB160/D	005-0007-01	NEURON CHIP Input/Output Timing Specification
EB161/D	005-0017-01	LONTALK Protocol
<b>Other</b>		
BR1134/D		NEURON CHIP Product Overview
LONPROD/D		LONWORKS Products
BR1139/D		LONWORKS Support Tools

**2**

# MOS Memories

---

## In Brief . . .

Motorola's MOS memory product portfolio has been expanded to support a broad range of engineering applications.

Motorola's Fast Static RAM division's goal is simple: speed. These high-density, high-speed products are targeted for specific solutions in microprocessor applications, providing access times as fast as 6 and 9 ns. Included in this portfolio are application-specific FSRAMs, along with standard and custom Fast Static RAM modules. Also included are asynchronous devices with access times of 6 ns at the 256K-bit density and 8 ns at 1 Megabit density.

The Dynamic Memory Products Division utilizes alliances as a vehicle for global customer support in the DRAM and memory module markets. The product portfolio consists of high-density DRAMs and standard and custom memory modules including DRAM PC cards and PCMCIA Flash cards.

	<b>Page</b>
Fast Static RAMs . . . . .	2.7-2
Introduction . . . . .	2.7-2
Application Specific Static RAMs . . . . .	2.7-2
BiCMOS Fast Static RAMs . . . . .	2.7-3
CMOS Fast Static RAMs . . . . .	2.7-3
Fast Static RAM Modules . . . . .	2.7-4
Dynamic RAMs . . . . .	2.7-5
Introduction . . . . .	2.7-5
DRAM Modules . . . . .	2.7-5
Flash Modules . . . . .	2.7-6
Dynamic RAMs (HCMOS) . . . . .	2.7-6
General Memory Products . . . . .	2.7-6
PCMCIA Flash Cards . . . . .	2.7-7
DRAM Memory Cards . . . . .	2.7-7



# Fast Static RAMs

## Introduction

Motorola is designing the fastest, most technologically advanced fast SRAMs. From 0.8  $\mu\text{m}$  to 0.5  $\mu\text{m}$  with access times as fast as 6 ns 256K, 8 ns 1M, and 12ns 4M, these devices are progressively smaller, faster, and lower cost. SRAMs with advanced BiCMOS technology will keep pace with machines of the future. Selected fast SRAMs are also available on 2M and 8M memory modules.

Application specific memories are designed for high-performance microprocessors that require more specialization from memory cache than is available from standard devices. Products include those for use with digital signal processors as well as a variety of popular microprocessors.

2

### APPLICATION SPECIFIC STATIC RAMS (7 to 35 ns)

Description	Organization	Motorola Part Number	Pin Count	Packaging	Access Time (ns Max)	Technology	Production	Comments
Processor Specific	64Kx18	MCM67B618	52	(FN) PLCC	9/10/12	BiCMOS	Now	Burst mode for i486™/Pentium™ (non-pipeline). 3.3 V I/O compatible.
			119	(ZP) BGA	9/10/12	BiCMOS	3Q94	
		MCM67C618	52	(FN) PLCC	6/7/9	BiCMOS	Now	Burst mode for i486/Pentium (pipeline). 3.3 V I/O compatible.
			119	(ZP) BGA	6/7/9	BiCMOS	3Q94	
		MCM67H618	52	(FN) PLCC	9/10/12	BiCMOS	2Q94	Supports Pentium pipeline address mode
		MCM67J618	52	(FN) PLCC	6/7/9	BiCMOS	2Q94	Supports Pentium pipeline address mode with data pipeline
	MCM67M618	52	(FN) PLCC	9/11/14	BiCMOS	Now	Burst mode for '040/PowerPC™ (non-pipeline). 3.3 V I/O compatible.	
	32Kx18	MCM67B518	52	(FN) PLCC	9/10/12	BiCMOS	2Q94	Burst mode for i486™/Pentium™ (non-pipeline). 3.3 V I/O compatible.
			119	(ZP) BGA	9/10/12	BiCMOS	3Q94	
		MCM67C518	52	(FN) PLCC	6/7/9	BiCMOS	2Q94	Burst mode for i486/Pentium (pipeline). 3.3 V I/O compatible.
			119	(ZP) BGA	6/7/9	BiCMOS	3Q94	
		MCM67H518	52	(FN) PLCC	9/10/12	BiCMOS	2Q94	Supports Pentium pipeline address mode
		MCM67J518	52	(FN) PLCC	6/7/9	BiCMOS	2Q94	Supports Pentium pipeline address mode with data pipeline
	MCM67M518	52	(FN) PLCC	9/11/14	BiCMOS	2Q94	Burst mode for '040/PowerPC (non-pipeline). 3.3 V I/O compatible.	
	32Kx9	MCM62486A	44	(FN) PLCC	11/12/14/19/24	HCMOS	Now	Burst mode for i486/Pentium applications $\geq$ 50 MHz.
			44	(FN) PLCC	10/11/12/14/19/24	HCMOS	3Q94	Replaces MCM62486A. Sampling 2Q94.
		MCM62940A	44	(FN) PLCC	11/12/14/19/24	HCMOS	Now	Burst mode for '040/PowerPC.
			44	(FN) PLCC	10/11/12/14/19/24	HCMOS	3Q94	Replaces MCM62940A. Sampling 2Q94.
8Kx24	MCM56824A	52	(FN) PLCC	20/25/35	HCMOS	Now	Designed for DSP56001 applications, replaces 3 8Kx8's.	
Latched	64Kx18	MCM67A618	52	(FN) PLCC	10/12/15	BiCMOS	Now	General asynchronous, latched address and data.
	32Kx18	MCM67A518	52	(FN) PLCC	10/12/15	BiCMOS	2Q94	General asynchronous, latched address and data.
	16Kx16	MCM62995A	52	(FN) PLCC	12-5/15/20/25	HCMOS	Now	DSP96000 and MIPS R3000 applications. Latch on address inputs.
Synchronous	128Kx9	MCM67D709	52	(FN) PLCC	6/7.5	BiCMOS	Now	Dual I/O for 88110 and other multiprocessor. 50MHz and 60MHz applications.
			86	(ZP) BGA	10/12	BiCMOS	2Q94	General synchronous separate I/O with write pass through.
		MCM67Q804	36	400 (WJ)SOJ	10/12	BiCMOS	Now	Graphics; general RISC. Register to register. Revolutionary pinout. 3.3 V I/O compatible. Write pass through. Separate I/O.
	16Kx16	MCM62990A	52	(FN) PLCC	12-5/15/20/25	HCMOS	Now	Designed for advanced RISC-CISC cache applications.
	32Kx9	MCM62110	52	(FN) PLCC	15/17/20	HCMOS	Now	Dual I/O's for 88110 and other multiprocessor applications.
	64Kx4	MCM62980	28	300 (J)SOJ	15/20	HCMOS	Now	For RISC and CISC systems; 1-stage pipeline.
			32	300 (J)SOJ	15/20	HCMOS	Now	Parity bit storage.
	8Kx16	MCM677316	44	(FN) PLCC	12	BiCMOS	3Q94	Synchronous cache tag with comparator. Samples 2Q94.
	8Kx8	MCM62X308	28	300 (J)SOJ	15-5/17	HCMOS	Now	Line buffer for processing digital data.
			32	300 (J)SOJ	15-5/17	HCMOS	Now	Line buffer for processing digital data with added roll-over flags.
	4Kx12	MCM62973A	44	(FN) PLCC	18/20	HCMOS	Now	Pipelined with chip select.
			44	(FN) PLCC	18/20	HCMOS	Now	Pipelined with output enable.
			44	(FN) PLCC	25/30	HCMOS	Now	Output enable.

**BICMOS FAST STATIC RAMS (6 to 15 ns)**

Density	Organization	Motorola Part Number	Pin Count	Packaging Package width in mils	Access Time (ns Max)	Technology	Production	Comments
4M	1Mx4	MCM101524	36	400 (TS)TSOP (TB)TAB	12/15	BICMOS	Now	100K ECL compatible @ - 5.2 V.
	2Mx2	MCM101525	36	400 (TS)TSOP (TB)TAB	12/15	BICMOS	Now	100K ECL compatible @ - 5.2 V.
1M	128Kx8	MCM6726	32	400 (WJ)SOJ	10/12/15	BICMOS	Now	Revolutionary pinout.
		MCM6726A	32	400 (WJ)SOJ	8/10/12/15	BICMOS	Now	Revolutionary pinout. Sampling 4Q93.
	256Kx4	MCM6728	28	400 (WJ)SOJ	10/12/15	BICMOS	Now	Revolutionary pinout.
		MCM6728A	28	400 (WJ)SOJ	8/10/12/15	BICMOS	Now	Revolutionary pinout. Sampling 4Q93.
		MCM6729	32	400 (WJ)SOJ	10/12/15	BICMOS	Now	With output enable. Revolutionary pinout.
MCM6729A	32	400 (WJ)SOJ	8/10/12/15	BICMOS	Now	With output enable. Revolutionary pinout.		
256K	32Kx8	MCM6706A	28	300 (J)SOJ	8/10/12	BICMOS	Now	Use for new quals and designs. Evolutionary pinout.
		MCM6706R	32	300 (J)SOJ	6/7/8	BICMOS	Now	Revolutionary pinout. Sampling 3Q93.
	32Kx9	MCM6705A	32	300 (J)SOJ	10/12	BICMOS	Now	Evolutionary pinout.
	64Kx4	MCM6708A	24	300 (J)SOJ	8/10	BICMOS	Now	Use for new quals and designs. Evolutionary pinout.
		MCM6709A	28	300 (J)SOJ	8/10	BICMOS	Now	Use for new quals and designs. Output enable. Evolutionary pinout.
MCM6709R	28	300 (J)SOJ	6/7/8	BICMOS	Now	Revolutionary pinout. Sampling 3Q93.		

**2**
**CMOS FAST STATIC RAMS (12 to 45 ns)**

Density	Organization	Motorola Part Number	Pin Count	Packaging Package width in mils	Access Time (ns Max)	Technology	Production	Comments
4M	512Kx8	MCM6246	36	400 (WJ)SOJ	20/25/35	HCMOS	2Q94	Output enable. Revolutionary pinout.
	1Mx4	MCM6249	32	400 (WJ)SOJ	20/25/35	HCMOS	2Q94	Output enable. Revolutionary pinout.
1M	128Kx8	MCM6226A	32	400 (WJ)SOJ	20/25/35/45	HCMOS	Now	Standard asynchronous.
		MCM6226B	32	300 (J), 400 (WJ)SOJ	15/20/25/35	HCMOS	2Q94	Standard asynchronous.
	256Kx4	MCM6229A	28	400 (WJ)SOJ	20/25/35/45	HCMOS	Now	Standard asynchronous.
		MCM6229B	28	300 (J), 400 (WJ)SOJ	15/20/25/35	HCMOS	2Q94	Standard asynchronous.
	1Mx1	MCM6227A	28	400 (WJ)SOJ	20/25/35/45	HCMOS	Now	Separate I/O.
MCM6227B		28	300 (J), 400 (WJ)SOJ	15/20/25/35	HCMOS	2Q94	Separate I/O.	
256K	16Kx16	MCM62996	52	(FN)PLCC	12-5/15/20/25	HCMOS	Now	Choice of 5 V or 3.3 V power supplies for output buffers. For wide bus applications.
	32Kx8	MCM6206D	28	300 (J)SOJ/(P)DIP	12/15/20/25	HCMOS	Now	Replaces MCM6206C.
		MCM6306D	28	300 (J)SOJ/(P)DIP	15/20/25/35	HCMOS	4Q94	Sampling 3Q94. First 3.3 V power supply.
	32Kx9	MCM6205D	32	300 (J)SOJ	15/20/25	HCMOS	Now	Replaces MCM6205C.
	64Kx4	MCM6208C	24	300 (J)SOJ/(P)DIP	12/15/20/25	HCMOS	Now	
MCM6209C		28	300 (J)SOJ/(P)DIP	12/15/20/25	HCMOS	Now	Output enable access time = 6 ns.	
64K	8Kx8	MCM6264C	28	300 (J)SOJ/(P)DIP	12/15/20/25/35	HCMOS	Now	Complementary chip enables.
	8Kx9	MCM6265C	28	300 (J)SOJ/(P)DIP	12/15/20/25/35	HCMOS	Now	Complementary chip enables.

**FAST STATIC RAM MODULES (Contact Fast Static RAM Marketing for Custom Fast SRAM Modules)**

Description	Organization	Motorola Part Number	Pin Count	Packaging	Access Time (ns Max)	Tech-nology	Pro-duction	Comments	
PowerPC™ Cache Module	32Kx72	MCM72MS32	136	DIMM	50/66 MHz	BICMOS	2Q94	256KB	Can be used in any PowerPC application
	64Kx72	MCM72MS64	136	DIMM	50/66 MHz	BICMOS	2Q94	512KB	
R4000 Secondary Cache Module	64Kx44	MCM4464 Series	80	(SG)SIMM	12/15/17	BICMOS	Now	1MB cache using 4 modules, all Tag options available.	4MB cache using 4 modules, all Tag options available.
	256Kx44	MCM44256 Series	80	(SG)SIMM	12/15/17	BICMOS	Now		
Standard FSRAM Modules	256Kx32	MCM32257	64	(Z)IP	20/25/35	HCMOS	Now	Uses 1M Fast SRAMs, JEDEC standard.	
	128Kx32	MCM32128	64	(Z)IP (SG) SIMM	20/25/35	HCMOS	Now Now	Industry standard x32 family.	
	64Kx32	MCM3264A	64	(Z)IP	15/20	HCMOS	Now	Designed for 32-bit systems, JEDEC standard.	
486 Cache Module with Tag and Altered Bit	32Kx32	MCM32A32	128	DIMM	33/50 MHz	HCMOS	Now	128KB	<ul style="list-style-type: none"> <li>Compatible with Multiple 486 Chip Set, Opti, SIS, UMC, VLSI, and others.</li> <li>Compact Dual Readout SIMM.</li> <li>Jumperless Cache Upgrade.</li> </ul>
	64Kx32	MCM32A64	128	DIMM	33/50 MHz	HCMOS	Now	256KB	
i486™ Cache Module with Tag (7, 8, or 9 bits), Valid, Altered Bit	32Kx32	MCM32Ax32 x = tag bits 7, 8, 9	112	Card Edge Connector	25/33/50 MHz	HCMOS	Now	128KB	<ul style="list-style-type: none"> <li>Complete cache solution for Intel 82420 PCI Chip Set.</li> </ul>
	64Kx32	MCM32Ax64 x = tag bits 7, 8, 9	112	Card Edge Connector	25/33/50 MHz	HCMOS	Now	256KB	
	128Kx32	MCM32Ax128 x = tag bits 7, 8, 9	112	Card Edge Connector	25/33/50 MHz	HCMOS	2Q94	512KB	
Pentium™ Secondary Cache Module	32Kx64	MCM64AA32	136	DIMM	12/15	HCMOS	2Q94	256KB	<ul style="list-style-type: none"> <li>68 Pin SIMM Form Factor.</li> <li>Complete cache for Intel 82430 PCI Chip Set.</li> <li>Complete cache for Intel 82430 PCI Chip Set.</li> <li>160 Pin Card Edge</li> </ul>
	32Kx72	MCM72BA32	136	DIMM	50/60/66 MHz	BICMOS	2Q94	256KB	
	64Kx72	MCM72BA64	136	DIMM	50/60/66 MHz	BICMOS	Now	512KB	
	32Kx64	MCM64AB32	160	Card Edge Connector	12/15	HCMOS	2Q94	256KB	
	32Kx72	MCM72BB32	160	Card Edge Connector	60/66 MHz	BICMOS	2Q94	256KB	
	64Kx72	MCM72BB64	160	Card Edge Connector	60/66 MHz	BICMOS	2Q94	512KB	

2

# Dynamic RAMs

## Introduction

DRAMs offer the lowest cost per bit of any memory. Because of this, they are popular for a wide range of applications, particularly in the computing environment. Motorola's Dynamic Memory Products include DRAM components and memory modules including DRAM PC cards and PCMCIA Flash cards. The 4 and 16 MByte DRAM components are offered in various organizations and surface mount packaging. Motorola's DRAM memory modules

include densities up to 64 MByte in both standard and custom configurations. The 88-pin DRAM PC card conforms to JEDEC/JEDIA standards, while the 68-pin Flash card is fully PCMCIA compatible.

All devices are fabricated using HCMOS technology and operate in a 5-volt power supply. However, specific DRAM products are designed for use in either a 3.3 Volt or 5-Volt power supply.

### DRAM MODULES (Contact DRAM Marketing for Custom DRAM Modules)

Organization	Byte Density	Motorola Part Number	Pin Count	Packaging	Address Access Time (ns Max)	Operating Current (mA Max)	Production	Comments
1Mx8	1MB	MCM81000	30	(S), (AS), (LH), (L)	70/80	640/560	Now	30-pad SIMM package
		MCM81430	30	(S), (L)	60/70	240/200	Now	30-pad SIMM package; 2-chip version
		MCM84000	30	(AS), (L)	60/70	960/800	Now	30-pad SIMM package
		MCM84030	30	(LH)	60/70	960/800	Now	30-pad SIMM package; low height (0.52 in) version
4Mx8	4MB	MCM81600	30	(S), (L)	60/70	960/800	Now	30-pad SIMM package
		MCM91000	30	(S), (AS, (L), (LH), (SG)	70/80	720/630	Now	30-pad SIMM package for parity application
		MCM91430	30	(S), (L), (SC)	60/70	330/280	Now	30-pad SIMM package for parity application; 3-chip version
		MCM94000	30	(AS), (ASG), (LH), (SC)	60/70	1080/900	Now	30-pad SIMM package for parity application
16Mx8	16MB	MCM94030	30	(L)	60/70	1080/900	Now	30-pad SIMM package for parity application; low height (0.52 in) version
		MCM91600	30	(S), (SG)	60/70	810/720	Now	30-pad SIMM package for parity application
		MCM18100	72	(AS), (ASG)	60/70	240/220	Now	72-pad SIMM package for 16 bit parity application
		MCM18200	72	(S), (SG)	60/70	672/572	Now	72-pad SIMM package for 16 bit parity application
4Mx18	8MB	MCM18400	72	(AS), (ASG)	60/70	240/220	Now	72-pad SIMM package for 16 bit parity application
		MCM18800	72	(S), (SG)	60/70	732/612	Now	72-pad SIMM package for 16 bit parity application
		MCM32100D	72	(D), (DG)	60/70	960/800	Now	Small outline DIMM package, 5 V
		MCM32103D	72	(D), (DG)	80	480	Now	Small outline DIMM package, 3.3 V
2M x 32	8MB	MCM32130	72	(SH), (SHG), (SSH)	60/70	960/800	Now	72-pad SIMM package
		MCM32230	72	(SH), (SHG)	60/70	976/816	Now	72-pad SIMM package
		MCM32400	72	(S), (SG)	60/70	960/800	Now	72-pad SIMM package
		MCM32400D	72	(D), (DG)	60/70	720/640	Now	Small outline DIMM package, 5 V, 4K refresh
8Mx32	32MB	MCM32410	72	(S), (SG)	60/70	3840/3200	Now	Double-sided module using 4M DRAM
		MCM32420D	72	(D), (DG)	60/70	800/680	Now	MCM32400 small outline package, 5.0 V
		MCM32800	72	(S), (SG)	60/70	976/816	Now	72-pad SIMM package
		MCM33100	72	(S), (SG)	60/70	1050/880	Now	MCM32100 with single bit parity
1Mx36	4MB	MCM36100	72	(AS), (ASG), (ASH), (ASHG)	60/70	1320/1120	Now	72-pad SIMM package for parity application
		MCM36104	72	(S), (SG)	60/70	1080/900	Now	72-pad SIMM package for ECC, and parity application
		MCM36200	72	(AS), (ASG)	60/70	1344/1144	Now	72-pad SIMM package for parity application
		MCM36204	72	(S), (SG)	60/70	1098/918	Now	72-pad SIMM package for ECC, and parity application
4Mx36	16MB	MCM36400	72	(AS), (ASG), (ASH), (ASHG)	60/70	1440/1200	Now	72-pad SIMM package for parity application
		MCM36404	72	(SG)	60/70	810/720	Now	ECC pinouts (4K refresh), for parity application
		MCM36800	72	(S), (SG)	60/70	1464/1224	Now	72-pad SIMM package for parity application
		MCM36804	72	(SG)	60/70	828/738	Now	ECC pinouts (4K refresh), for parity application
1Mx40	4MB for EDC	MCM40100	72	(AS), (ASG)	60/70	1200/1000	Now	72-pad SIMM package for ECC application
2Mx40	8MB for EDC	MCM40200	72	(AS), (ASG)	60/70	1220/1020	Now	72-pad SIMM package for ECC application
		MCM40400	72	(S), (SG)	60/70	1200/1000	3Q94	Replaces MCM40420; Sampling 2H94
		MCM40420	72	(S), (SG)	60/70	1200/1000	Now	72-pad SIMM for ECC application
		MCM40800	72	(S), (SG)	60/70	1220/1020	3Q94	72-pad SIMM for ECC application; Sampling 2H94
1Mx64	8MB	MCM64100	84	(D)IMM	60/70		4Q94	168-pad DIMM package
4Mx64	32MB	MCM64400	84	(D)IMM	60/70		4Q94	168-pad DIMM package

2

## FLASH MODULES

Organi- zation	Byte Density	Motorola Part Number	Pin Count	Packaging	Address Access Time (ns Max)	Operating Current (mA Max)	Pro- duction	Comments
512Kx32	2MB	MCM29020	80	(S)	90	240	2Q94	JEDEC Standard FLASH SIMM
1Mx32	4MB	MCM29040	80	(S)	90	248	2Q94	JEDEC Standard FLASH SIMM
2Mx32	8MB	MCM29080	80	(S)	90	252	2Q94	JEDEC Standard FLASH SIMM

NOTE: Package suffixes are enclosed by ( ) in packaging column.

AS = SIMM (Board Revision)  
ASG = Gold Pad SIMM (Board Revision)  
ASH = Low Profile SIMM  
ASHG = Low Profile Gold Pad SIMM

D/DG = Dual Inline Module/Dual Inline Gold Pad Module  
L = SIP  
LH = Low Height SIP  
S = SIMM

SC = Industrial Temperature SIMM  
SG = Gold Pad SIMM  
SH = Short Height SIMM  
SSH = Super Short Height SIMM  
SHG = Short Height Gold Pad SIMM

2

## DYNAMIC RAMS (HCMOS) (Contact DRAM Marketing)

Density	Organi- zation	Motorola Part Number	Pin Count	Packaging Package width in mils	Address Access Time (ns Max)	Operating Current (mA Max)	Pro- duction	Comments	
1M	1Mx1	MCM511000A	18, 20, 20/26	300 (P)DIP, 100 (Z)IP	70/80	80/70	Now	No new customers. No orders after June 93	
		MCM51L1000A	18, 20, 20/26	300 SO(J)	70/80	80/70	Now	No new customers. Orders limited after Sept 93	
	256Kx4	MCM514256A	18, 20, 20/26	300 (P)DIP, 100 (Z)IP	70/80	80/70	Now	No new customers. No orders after June 93	
		MCM51L4256A	18, 20, 20/26	300 SO(J)	70/80	80/70	Now	No new customers. Orders limited after Sept 93	
4M	4Mx1	MCM441100B	20/26	300 SO(J)	60/70	110/100/90	Now	Fast page mode cycle time = 40/45/50 ns	
		MCM4L4100B	20/26	300 SO(J)	60/70	110/100/90	Now	Low power	
		MCM541100A	20, 20/26	300 SO(J), 300 (T)SOP	60/70	120/100	Now	Fast page mode cycle time = 45/45 ns	
		MCM5L4100A	20, 20/26	300 SO(J), 300 (T)SOP	60/70	120/100	Now	Low power	
		MCM54100A-C	26	300 SO(J)	70/80	100/85	Now	Industrial temp range (- 40° to + 85°C)	
		MCM44400B	20/26	300 SO(J)	60/70	110/100/90	Now	Fast page mode cycle time = 40/45/50 ns	
	1Mx4	MCM4L4400B	20/26	300 SO(J)	60/70	110/100/90	Now	Low power	
		MCM54400A	26	300 SO(J)(N), 300 (T)SOP	60/70	120/100/85	Now	Fast page mode cycle time = 45/45 ns	
		MCM5L4400A	26	300 SO(J)(N), 300 (T)SOP	60/70	120/100/85	Now	Low power	
		MCM54400A-C	26	300 SO(J)	70/80	100/85	Now	Industrial temp range (- 40 to + 85°C)	
		MCM54400A-V	26	300 SO(J)(N), 300 (T)SOP	80	60	Now	3.3 V Fast page mode cycle time = 50 ns	
		512Kx8	MCM54800A	28	400 SO(J), 400 (T)SOP	70/80	105/90	Now	Fast page mode cycle time = 45/50/60 ns
	MCM5L4800A		28	400 SO(J), 400 (T)SOP	70/80	105/90	Now	Low power	
	MCM5V4800A		28	400 SO(J), 400 (T)SOP	70/80	105/90	Now	Low power, self refresh	
	256Kx16	40, 40/44	MCM54170B	40, 40/44	400 SO(J), 400 (T)SOP	70/80/10	75/65	TBD	Fast page mode, 1 CAS, 2 W, 1K refresh
			MCM5L4170B	40, 40/44	400 SO(J), 400 (T)SOP	70/80/10	75/65	TBD	Low power
			MCM5V4170B	40, 40/44	400 SO(J), 400 (T)SOP	70/80/10	75/65	TBD	Low power, self refresh
			MCM54260B	40, 40/44	400 SO(J), 400 (T)SOP	70/80/10	100/85	Now	Fast page mode, 2 CAS, 1 W, 512 refresh
			MCM5L4260B	40, 40/44	400 SO(J), 400 (T)SOP	70/80/10	100/85	Now	Low power
			MCM5V4260B	40, 40/44	400 SO(J), 400 (T)SOP	70/80/10	100/85	Now	Low power, self refresh
	256Kx18	40, 40/44	MCM54190B	40, 40/44	400 SO(J), 400 (T)SOP	70/80/10	75/65	TBD	Fast page mode, 1 CAS, 2 W, 1K refresh
			MCM5L4190B	40, 40/44	400 SO(J), 400 (T)SOP	70/80/10	75/65	TBD	Low power
			MCM5V4190B	40, 40/44	400 SO(J), 400 (T)SOP	70/80/10	75/65	TBD	Low power, self refresh
			MCM54280B	40, 40/44	400 SO(J), 400 (T)SOP	70/80/10	110/95	Now	Fast page mode, 2 CAS, 1 W, 512 refresh
MCM5L4280B			40, 40/44	400 SO(J), 400 (T)SOP	70/80/10	110/95	Now	Low power	
MCM5V4280B			40, 40/44	400 SO(J), 400 (T)SOP	70/80/10	110/95	Now	Low power, self refresh	
16M	16Mx1	MCM516100	24/26	400 SO(J), 400 (T)SOP	60/70	90/80	Now	4K refresh	
		MCM516100BJ	24/26	300 SO(J)	50/60/70	110/90/80	4Q94	Narrow package	
		MCM516100BT	24/26	300 (T)SOP	50/60/70	110/90/80	4Q94	Narrow package	
	4Mx4	MCM516400	24/28	400 SO(J), 400 (T)SOP	60/70	90/80	Now	4K refresh, 12 row, 10 column	
		MCM517400	24/28	400 SO(J), 400 (T)SOP	60/70	120/100	Now	2K refresh, 11 row, 11 column	
		MCM516400B	24/26	300 SO(J), 300 (T)SOP	50/60/70	110/90/80	4Q94	4K refresh, 5 V/3.3 V, Fast Page Mode	
		MCM517400B	24/26	300 SO(J), 300 (T)SOP	50/60/70	140/130/110	4Q94	2K refresh, 5 V/3.3 V, Fast Page Mode	
	1Mx16	MCM516160AJ	42	400 SO(J)	60/70/80	95/80/70	3Q94	4K refresh, 12 row, 8 column	
		MCM516160AT	44/50	400 (T)SOP	60/70/80	95/80/70	3Q94	4K refresh	
		MCM518160AJ	42	400 SO(J)	70/80	140/120	3Q94	1K refresh, 5 V/3.3 V, 10 row, 10 column	
		MCM518160AT	44/50	400 (T)SOP	70/80	140/120	3Q94	1K refresh, 5 V/3.3 V	
	1Mx18	MCM516180AJ	42	400 SO(J)	60/70/80	105/90/80	4Q94	4K refresh, 12 row, 8 column	
		MCM516180AT	44/50	400 (T)SOP	60/70/80	105/90/80	4Q94	4K refresh	
		MCM518180AJ	42	400 SO(J)	70/80	150/130	4Q94	1K refresh, 5 V/3.3 V, 10 row, 10 column	
		MCM518180AT	44/50	400 (T)SOP	70/80	150/130	4Q94	1K refresh, 5 V/3.3 V	

## GENERAL MEMORY PRODUCTS (Contact DRAM Marketing)

Density	Organi- zation	Motorola Part Number	Pin Count	Packaging Package width in mils	Address Access Time (ns Max)	Operating Current (mA Max)	Pro- duction	Comments
2K	256x8	MCM2814	8	300 (BP)DIP, 150 PSO(G)	100/200	10	Now	Byte programmable serial EEPROM

### PCMCIA FLASH CARDS

Byte Density	Motorola Part Number	Pin Count	Packaging	Address Access Time (ns Max)	Operating Current (mA Max)	Pro-duction	Comments
1MB	MCM29010E6	68	E	150	135	2Q94	68-pin PCMCIA Flash Memory Card, 5 V
2MB	MCM29020E6	68	E	150	135	2Q94	68-pin PCMCIA Flash Memory Card, 5 V
4MB	MCM29040E6	68	E	150	135	2Q94	68-pin PCMCIA Flash Memory Card, 5 V
10MB	MCM29100E6	68	E	150	135	2Q94	68-pin PCMCIA Flash Memory Card, 5 V

### DRAM MEMORY CARDS

Byte Density	Organi-zation	Motorola Part Number	Pin Count	Packaging	Address Access Time (ns Max)	Operating Current (mA Max)	Pro-duction	Comments
2MB	1Mx16	MCM16100R8	88	R	60/70	528/444	Now	88-pin DRAM Memory Card
	1Mx18	MCM16100R8	88	R	60/70	715/609	Now	88-pin DRAM Memory Card for parity application
4MB	2Mx16	MCM16200R8	88	R	60/70	744/635	Now	88-pin DRAM Memory Card
	2Mx18	MCM16200R8	88	R	60/70	744/635	Now	88-pin DRAM Memory Card for parity application
	1Mx32	MCM32100R8	88	R	60/70	1068/894	Now	88-pin DRAM Memory Card
	1Mx36	MCM36100R8	88	R	60/70	1393/1185	Now	88-pin DRAM Memory Card for parity application
8MB	2Mx32	MCM32200R8	88	R	60/70	1084/910	Now	88-pin DRAM Memory Card
	2Mx36	MCM36200R8	88	R	60/70	1452/1238	Now	88-pin DRAM Memory Card

NOTE: Package suffixes are enclosed by ( ) in packaging column.

E = 68 Pin PCMCIA Card

R = 88 Pin JEDEC Card

2

**2**

# TTL, ECL, CMOS and Special Logic Circuits

---

## In Brief . . .

Since the inception of IC technology, Motorola has earned a reputation as the supermarket for digital logic circuits. Although early circuit designs such as RTL, DTL, HTL, etc., have been largely supplanted by newer techniques, Motorola's reputation as a leading-edge supplier of standard logic families remains unchallenged.

Motorola currently concentrates on supplying those logic families and functions that advance the state-of-the-art as well as serving the needs of designers requiring interface circuits for more complex ICs and semicustom designs. It does so with three technologies:

- ECL (four unique families) for high speed
- TTL (two families) for high performance at lower cost
- CMOS (three families) for lowest power dissipation

This selector guide contains only devices in production at Motorola's Logic I.C. Division, accurate to the date of publication.

There are numerous new devices introduced between printings of the Master Selection Guide. Therefore, the Logic Division publishes a selector guide on a quarterly basis. This selector guide, SG366/D, can be ordered from your nearest Motorola Sales Office or from the Motorola Literature Distribution Center.

The Logic I.C. Division publishes a New Product Calendar quarterly that reflects any recent device releases and the approximate dates new devices are expected to be released.

There are many new devices in various stages of development on Motorola's Logic I.C. Division's design schedule. Call your nearest Motorola Sales Office for the current status of any device not listed within this guide.

	<b>Page</b>
Motorola Logic Families: Which Is Best for You? . . . .	3.1-3
Selection by Function	
Special Logic Circuits . . . . .	3.1-7
Cross-Functional Tables . . . . .	3.1-11
Numeric Listings	
Special Logic Circuits . . . . .	3.1-22
TTL . . . . .	3.1-26
MECL . . . . .	3.1-34
CMOS . . . . .	3.1-41
MECL III . . . . .	3.1-54
HTL/DTL Circuits . . . . .	3.1-54
Ordering Information . . . . .	3.1-55
Case Information . . . . .	3.1-58
Packaging Information . . . . .	3.1-62
Surface Mount . . . . .	3.1-62
Pin Conversion Tables . . . . .	3.1-62
Tape and Reel . . . . .	3.1-63
Logic Literature Listing . . . . .	3.1-64



**3**

# Motorola Logic Families, Which Is Best for You?

By Gary Tharalson, Motorola, Inc., Mesa, AZ

Selecting a logic family for a new design from today's rapidly changing semiconductor technologies can be a perilous task. There are huge ratios between the highest and lowest values of several characteristics — for speed it's 250:1, power 83,000:1, and output drive 24:1. With the many choices available, it is easy to under- or over-supply an application with inadequate or excessive capabilities. The purpose of this paper is to briefly describe the various technologies and compare their performance differences.

## Logic Families

Although many family technologies are available, they can be divided into roughly three broad categories: transistor-to-transistor logic (TTL), complementary metal-oxide semiconductor (CMOS) technology, and emitter coupled logic (ECL). TTL and ECL are bipolar technologies that differ in implementation techniques while CMOS (an MOS technology) differs in fundamental transistor structure and operation.

The designation "bipolar" refers to the basic component of TTL ICs, the bipolar npn transistor. Since the output drivers and the input buffers both use transistors, there is a direct transistor-to-transistor connection. Older technologies were interconnected via passive components like resistors and diodes.

Since the original TTL design, several enhancements have reduced power and increased speed. Common to these has been the use of Schottky diodes, which, ironically, no longer result in strictly TTL connections. The two names, Schottky and TTL, are used in combination: LS (Low power Schottky),

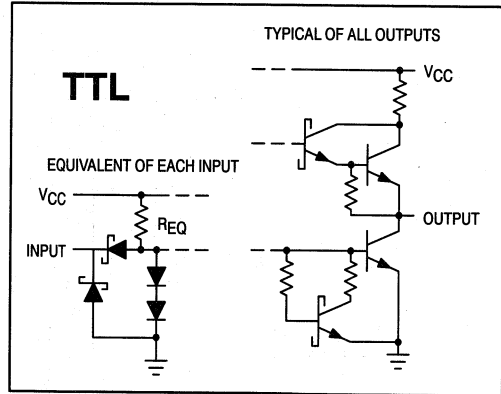

ALS (Advanced Low power Schottky), and National Semiconductor's FAST (Advanced Schottky) TTL.

The outstanding characteristics of TTL compared to CMOS in the past have been its higher speed, output drive, and transistor gain. These advantages are rapidly diminishing.

CMOS field-effect transistors differ from bipolar transistors both in structure and operation. The primary advantages of CMOS are its low power dissipation and small physical geometry. Recent advances in design and fabrication have brought CMOS devices into the same speed and output drive arena as TTL. Again, enhancements have resulted in additional classifications: MG (Metal-Gate CMOS), HC (High-speed silicon gate CMOS), and National Semiconductor's FACT (Advanced CMOS).

ECL derives its name from the common differential-amplifier configuration in which one side of the diff-amp consists of multiple input bipolar transistors with their emitters tied together. An input bias on the opposite side of the diff-amp causes the amplifier to operate continuously, rather than saturating high or low. Consequently, ECL consumes significant power in either state but results in the fastest switching speeds of all the logic families listed in the *table*, "Characteristics of Logic Families."

There have also been many evolutionary advancements in ECL. Four of the most recent families are 100K (1975), 10H (1981), and Motorola's ECLinPS (1987) and ECLinPS Lite (1992).

3

# 3

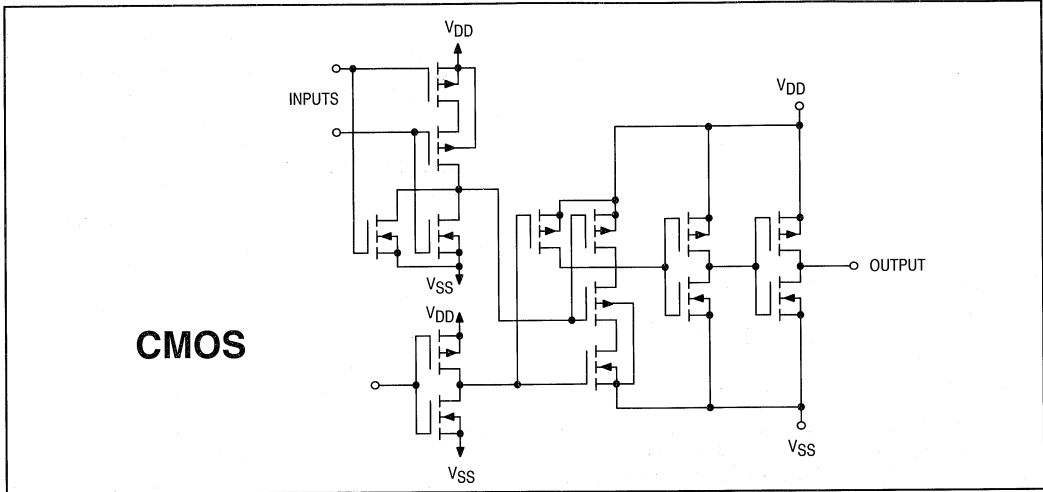

### Speed

Speed is typically the first specification designers look at. When they are asked what features of a logic family they would like enhanced, usually they want more speed. But increased speed often brings potential problems, including increased noise generation, higher power consumption, increased component and system cost, and more difficult board layout. Obviously, the other family characteristics must be considered also.

In the table, family speed is compared using typical values for three specs: propagation delay through a simple gate, flip-flop toggle frequency, and output switching time. Typical values can be misleading because they are frequently specified according to different vendors' criteria, but they are usually an average of minimum and maximum values.

For a final assessment of a particular component's performance, the minimum/maximum specifications in most vendors' data books should be examined. Furthermore, the switching (edge) rate is highly load dependent. Once again, data book specifics must be compared.

### Power Consumption

The amount of power an application consumes and the heat generated are frequently of prime importance. Power dis-

sipation, one of the major differences between the three families, may limit the designer's choices.

TTL power consumption is moderate and constant over operating frequencies up to about 10 MHz. It then begins to climb rapidly. Although only a few milliwatts are consumed by each device, a complete system may use substantial power.

CMOS power consumption, on the other hand, is highly frequency dependent. At quiescent (zero frequency), it consumes almost no power at all, measured in microwatts per device. However, its consumption grows almost linearly with frequency, so at maximum operating frequency it may be several milliwatts per device. The great power advantage of CMOS derives from the fact that in most applications, most of the devices will not be operating simultaneously at high frequencies at any given time. Consequently, the average system power is greatly diminished.

Because of its inherent design, ECL consumes the most power at frequencies below about 30 MHz. However, at higher frequencies, TTL and CMOS can consume more. The power used by ECL is fairly constant over its entire operating frequency range. Designers of large, high-performance ECL systems may have to use more complex cooling and power distribution techniques.

### Characteristics of Logic Families

Typical Commercial Parameter (0°C To +70°C)	Logic Families								
	TTL			CMOS			ECL		
	LS	ALS	FAST	MG	HC	FACT	10H	100K	ECLinPS**
<b>Speed</b> OR gate propagation delay ( $t_{pLH}$ ) (ns) D flip-flop toggle rate (MHz) Output edge rate (ns)	9 33 6	7 45 3	3 125 2	65 4 50	8 45 4	5 160 2	1 330 1	0.75 400 0.7	0.33 1,000 0.5
<b>Power Consumption Per Gate (mW)</b> Quiescent Operating (1 MHz)	5 5	1.2 1.2	12.5 12.5	0.0006 0.04	0.003 0.6	0.003 0.8	25 25	50 50	25 25
<b>Supply Voltage (V)</b>	+4.5 to +5.5	+4.5 to +5.5	+4.5 to +5.5	+3 to +18	+2 to +6	+2 to +6	-4.9 to -5.5	-4.2 to -4.8	-4.9 to -5.5/ -4.2 to -4.8
<b>Output Drive (mA)</b>	8	8	20	1	4	24	50-Ω load	50-Ω load	50-Ω load
<b>DC Noise Margin (%)*</b> High Input Low Input	22 10	22 10	22 10	30 30	30 30	30 30	27 31	41 31	28/41 31/31
<b>Packaging</b> DIP SO PLCC	Yes Yes No	Yes Yes Yes	Yes Yes Yes	Yes Yes No	Yes Yes No	Yes Yes Yes	Yes No Yes	Yes No No	No No Yes
<b>Functional Device Types</b>	157	195†	103	104	122	144	93	44†	74
<b>Relative 1-25 Quantity Price/Gate</b>	1	1	1	1	1.2	1.2	2	10	28

\*Typical noise margin expressed as a percentage of typical output voltage swing.

\*\*ECLinPS and ECLinPS Lite are available in both 10H- and 100K-compatible versions.

†Estimates

#### Manufacturers Referenced:

(LS) Motorola Low power Schottky TTL  
 (ALS) Texas Instruments Advanced Low  
 (FAST) Motorola Advanced Schottky TTL  
 (MG) Motorola 14000 Series Metal Gate CMOS

(HC) Motorola High-speed silicon gate CMOS  
 (FACT) Motorola Advanced CMOS  
 (10H) Motorola 10H Series ECL  
 (100K) National 100K Series ECL  
 (ECLinPS/Lite) Motorola advanced ECL

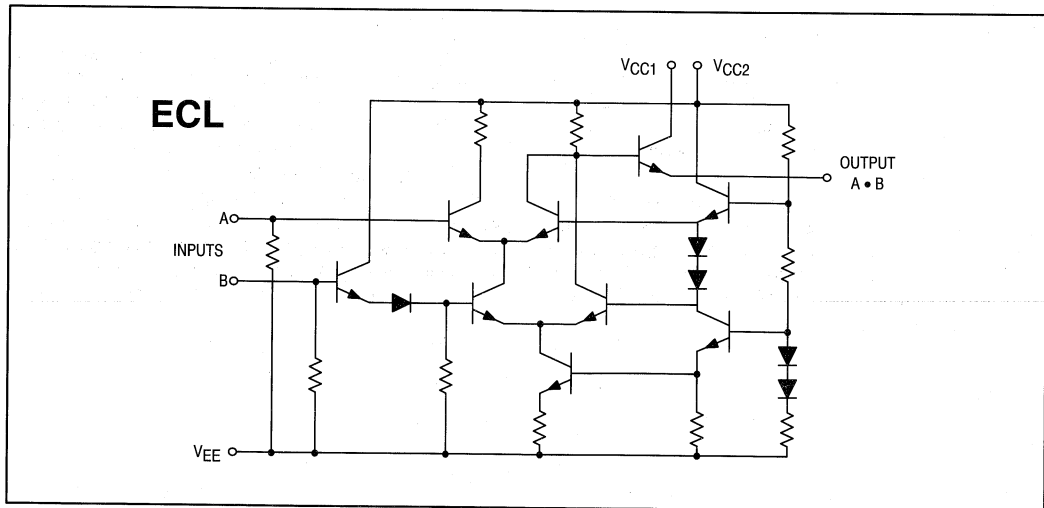

### Supply Voltage

The power supply voltage required for TTL and ECL is restricted to fixed values. Only a narrow voltage variation is allowed for the device to remain within specifications. Since these families also consume substantial amounts of power, there is a large current flow through the power lines.

To avoid unacceptable voltage fluctuation, various preventive measures may be necessary, such as remote sensing of the supply regulator, heavy power buses and filters, and multi-layer pc boards with separate power and ground planes. Typically, a high-speed energy-storage capacitor is required near each logic device. That capacitor maintains the correct device voltage during high current switching.

An important advantage of CMOS is the large range of supply voltage over which operation is specified, particularly at lower values. By allowing systems to be operated at voltages as low as 2 to 3V, not only is power consumption lowered but noise generation from fast signal switching is reduced. In similar fashion, the narrow switching level swings of ECL (about 800 mV) helps to moderate its noise generation.

### Output Drive

An important characteristic of a logic device is its ability to drive relatively large loads directly. This eliminates the requirement for special interface buffers. The older families within TTL and especially CMOS had only limited drive capability (below 10mA). All of the advanced logic family versions have significantly increased drive capacity. Several (FACT and all ECL) are capable of driving 50-Ω transmission lines directly. Furthermore, because of the symmetrical sink/source capability of FACT, its rise and fall times are nearly equal, resulting in balanced delay times.

### Noise Margin

Noise immunity refers to the resistance of a logic device to undesired switching. Depending on the input level, a noise glitch that causes a transient large enough to cross the input switch point can result in erroneous operation. Clearly, the larger the voltage difference between the switch point and the normal input high and low levels, the more the immunity to erroneous switching. In the table, these differences are expressed as a percentage of the swing between typical output high- and low-voltage logic levels.

The venerable dual-in-line package (DIP) has been, and still is, very popular. One reason is the ease with which prototype circuits using it can be fabricated and debugged. Particularly prominent is that an industry standard pinout arrangement, which puts power and ground on the end pins, has been

adopted for all the TTL and CMOS families in the accompanying table.

### Package Standardization

This standard package not only eases design procedures but also simplifies final production testing. This same standardization has been carried over to the new small-outline (SO) package for surface mounting. The SO package averages about 70% smaller in footprint than a DIP.

Fast switching of several outputs simultaneously (such as on an octal interface device) may result in a phenomenon called "ground bounce" voltage. This results partially from ground path current flow through internal lead inductance, and from the interaction between internal input and output ground paths.

Although present ground bounce voltage is well below CMOS trigger levels, TTL input devices may require special consideration. A number of approaches to internal circuit and package design have been developed to reduce ground current effects. Indications are that ground bounce will soon be reduced to nominal levels.

### More Devices, Less Space

Lower product costs can result from packing more logic devices into less pc board space and then using automation to assemble and test the product. This opportunity is vastly enhanced by the ability of present technology to supply thousands of identical surface-mounting packages on a single large tape-and-reel for high-speed pick-and-place machines. A user's package preference — SO or PLCC — is dictated mainly by the available production assembly capabilities.

Package material has also benefited from improvements in manufacturing technology. Thus, the majority of packages that are shipped today (for commercial applications) are constructed from relatively inexpensive plastic material.

### Mix and Match

Many designers have found that the best approach to achieving their particular application performance goal is to combine devices from several families. This is especially easy in the TTL and CMOS families because of their industry-standard pinouts, particularly for power and ground.

The obvious advantage of mixing and matching is to optimize the requirements of selected portions of a design, whether for speed, power consumption, output drive, or cost. Some disadvantages are that devices must be analyzed and tested for compatibility, inventories may increase, and some performance parameters may be compromised.

# Selection by Function

## Special Logic Circuits

### ALExis — Advance Low-Power Expandable Interface Solutions

Function	Device	Family
<b>Buffer</b>		
20-Bit Buffer (3-State, Inverting)	MC20LX240	BICMOS
20-Bit Buffer (3-State, Non-Inverting)	MC20LX244	BICMOS
<b>Flip-Flop</b>		
20-Bit D Type Flip-Flop (3-State, Non-Inverting)	MC20LX374	BICMOS
<b>Transceiver</b>		
16-Bit Latching Transceiver (3-State, Non-Inverting)†	MC16LX543	BICMOS
16-Bit Transceiver/Registered Transceiver W/ Multiplexed Outputs (3-State, Non-Inverting)†	MC16LX646	BICMOS
20-Bit Transceiver (3-State, Non-Inverting)	MC20LX245	BICMOS
<b>Register</b>		
1616-Bit Bidirectional Register With Clock Enable (3-State, Non-Inverting)†	MC16LX952	BICMOS
<b>Latch</b>		
18-Bit Transparent Latch With Preset and Reset (3-State, Non-Inverting)	MC18LX843	BICMOS
20-Bit Transparent Latch (3-State, Non-Inverting)	MC20LX373	BICMOS

3

### Timing Solutions

Function	Device	Family
<b>Clock Drivers</b>		
1:2 Differential Clock Driver	MC10/100EL11	ECLinPS Lite
1:6 Differential Clock Distribution Chip	MC10/100E211	ECLinPS
1:8 PECL/TTL to TTL Clock Distribution Chip	MC10/100H646	MECL 10H
1:9 Differential Clock Driver With Low Skew, Enable, $V_{bb}$	MC10/100E111	ECLinPS
1:9 TTL-TTL Clock Distribution Chip	MC10H645	MECL 10H
68030/040 PECL/TTL-TTL Clock Driver (Single @ 5.0 V)	MC10/100H640	MECL 10H
68030/040 PECL/TTL-TTL Clock Driver (Similar to H640)	MC10/100H642	MECL 10H
68030/040 PECL/TTL-TTL Clock Driver	MC10/100H644	MECL 10H
Clock Driver, Quad D-Type Flip-Flop, With Matched Propagation Delays	MC74F1803	FAST
Clock Driver, Quad D-Type Flip-Flop, With Matched Propagation Delays	MC74F803	FAST
Dual Supply ECL/TTL 1:8 Clock Driver	MC10/100H643	MECL 10H
Low Skew CMOS Clock Driver	MC88913	CMOS
Low Skew CMOS Clock Driver With Reset	MC88914	CMOS
55MHz Low Skew CMOS PLL Clock Driver	MC88915*55	CMOS
70MHz Low Skew CMOS PLL Clock Driver	MC88915*70	CMOS
55MHz Low Skew CMOS PLL Clock Driver, 3-State	MC88915T*55	CMOS
70MHz Low Skew CMOS PLL Clock Driver, 3-State	MC88915T*70	CMOS
100MHz Low Skew CMOS PLL Clock Driver, 3-State	MC88915T*100	CMOS

† = New Device

### Timing Solutions (continued)

Function	Device	Family
<b>Clock Drivers</b>		
133MHz Low Skew CMOS PLL Clock Driver, 3-State†	MC88915T*133	CMOS
160MHz Low Skew CMOS PLL Clock Driver, 3-State†	MC88915T*160	CMOS
70MHz Low Skew CMOS PLL Clock Driver With Processor Reset	MC88916*70	CMOS
80MHz Low Skew CMOS PLL Clock Driver With Processor Reset	MC88916*80	CMOS
50MHz Low Skew CMOS PLL Clock Driver With Power-Up/Power-Down	MC88920	CMOS
66MHz Low Skew CMOS PLL Clock Driver With Power-Up/Power-Down†	MC88921	CMOS
Single Supply PECL/TTL 1:9 Clock Distribution Chip	MC10/100H641	MECL 10H
<b>Programmable Delay Chips</b>		
Programmable Delay Chip (Dig. 20ps Anal. Ps/mv)	MC10/100E196	MECL
Programmable Delay Chip (Digitally Selectable 20ps Res.)	MC10/100E195	MECL

† = New Device

3

### Translators

Function	Device	Family
9-Bit ECL-TTL Translator	MC10/100H601	MECL 10H
9-Bit Latch/ECL-TTL Translator	MC10/100H603	MECL 10H
9-Bit Latch/TTL-ECL Translator	MC10/100H602	MECL 10H
9-Bit TTL-ECL Translator	MC10/100H600	MECL 10H
ECL-to-TTL Translator (Single P.S. @ + 5.0V)	MC10H350	MECL 10H
Hex MECL 10K-to-MST Translator	MC10191	MECL 10K
Hex TTL OR CMOS to CMOS Hex Level Shifter	MC14504B	CMOS
Quad CMOS-to-ECL Translator (Single P.S. @ + 5.0V)	MC10H352	MECL 10H
Quad MECL-to-TTL Translator	MC10H125	MECL 10H
Quad MECL-to-TTL Translator	MC10125	MECL 10K
Quad MST-to-MECL 10K Translator	MC10190	MECL 10K
Quad TTL/NMOS-to-PECL Translator (Single P.S. @ + 5.0V)	MC10H351	MECL 10H
Quad TTL-to-MECL Translator, With TTL Strobe Input	MC10H124	MECL 10H
Quad TTL-to-ECL Translator (ECL Strobe)	MC10H424	MECL 10H
Quad TTL-to-MECL Translator	MC10124	MECL 10K
Triple MECL-to-NMOS Translator	MC10177	MECL 10K
Registered Hex TTL/ECL Translator	MC10/100H604	MECL 10H
Registered Hex ECL/TTL Translator	MC10/100H605	MECL 10H
Registered Hex TTL/PECL Translator	MC10/100H606	MECL 10H
Registered Hex PECL/TTL Translator	MC10/100H607	MECL 10H
Differential ECL-to-TTL Translator†	MC10/100ELT25	ECLinPS Lite

† = New Device

**CBM**

Function	Device	Family
Carrier Band Modem	MC68194	MECL

**SCSI Bus Terminator**

Function	Device	Family
9–Bit Switchable Passive SCSI Bus Terminator (220Ω to 330Ω)	MCCS142233	CMOS
9–Bit Switchable Active SCSI Bus Terminator (110Ω)	MCCS142234	CMOS
18–Bit Active SCSI Bus Terminator (Also Available in 32–Pin QFP Package)	MCCS142235	CMOS

**Memory Support**

Function	Device	Family
Quad Dual Output ECL–TTL DRAM Driver With Latch	MC10/100H660	MECL 10H

**Industrial Control Unit**

Function	Device	Family
Industrial Control Unit	MC14500B	CMOS

**Bounce Eliminator**

Function	Device	Family
Hex Contact Bounce Eliminator	MC14490	CMOS

**3****Phase–Locked Loop**

Function	Device	Temperature Range
----------	--------	-------------------

**Prescalers**

1.1GHz +2 Low Power Prescaler with Stand–By Mode	MC12083	–40° to +85°C
1.1GHz +256 Prescaler	MC12074	0° to +70°C
1.1GHz +32/33, +64/65 Dual Modulus Prescaler	MC12028A	–40° to +85°C
1.1GHz +32/33, +64/65 Dual Modulus Prescaler	MC12028B	–40° to +85°C
1.1GHz +64 Prescaler	MC12073	0° to +70°C
1.1GHz +64/65, +128/129 Dual Modulus Prescaler	MC12022A	–40° to +85°C
1.1GHz +64/65, +128/129 Dual Modulus Prescaler	MC12022B	–40° to +85°C
1.1GHz +64/65, +128/129 Dual Modulus Prescaler	MC12022SLA	–40° to +85°C
1.1GHz +64/65, +128/129 Dual Modulus Prescaler	MC12022SLB	–40° to +85°C
1.1GHz +64/65, +128/129 Dual Modulus Prescaler	MC12022TSA	–40° to +85°C
1.1GHz +64/65, +128/129 Dual Modulus Prescaler	MC12022TSB	–40° to +85°C
1.1GHz +64/65, +128/129 Dual Modulus Prescaler with Stand–By Mode	MC12036A	–40° to +85°C
1.1GHz +64/65, +128/129 Dual Modulus Prescaler with Stand–By Mode	MC12036B	–40° to +85°C
1.1GHz +64/65, +128/129 Low Voltage Dual Modulus Prescaler	MC12022LVA	–40° to +85°C
1.1GHz +64/65, +128/129 Low Voltage Dual Modulus Prescaler	MC12022LVB	–40° to +85°C
1.1GHz +64/65, +128/129 Low Voltage Dual Modulus Prescaler	MC12022TVA	–40° to +85°C
1.1GHz +64/65, +128/129 Low Voltage Dual Modulus Prescaler	MC12022TVB	–40° to +85°C
1.3GHz +256 Prescaler	MC12076	0° to +85°C
1.3GHz +256 Prescaler	MC12078	0° to +85°C
2.0GHz +32/33, +64/65 Dual Modulus Prescaler	MC12034A	–40° to +85°C
2.0GHz +32/33, +64/65 Dual Modulus Prescaler	MC12034B	–40° to +85°C
2.0GHz +32/33, +64/65 Low Voltage Dual Modulus Prescaler	MC12033A	–40° to +85°C



3

**Phase-Locked Loop** (continued)

Function	Device	Temperature Range
2.0GHz +32/33, +64/65 Low Voltage Dual Modulus Prescaler	MC12033B	-40° to +85°C
2.0GHz +64/65, +128/129 Dual Modulus Prescaler	MC12032A	-40° to +85°C
2.0GHz +64/65, +128/129 Dual Modulus Prescaler	MC12032B	-40° to +85°C
2.0GHz +64/65, +128/129 Low Voltage Dual Modulus Prescaler	MC12031A	-40° to +85°C
2.0GHz +64/65, +128/129 Low Voltage Dual Modulus Prescaler	MC12031B	-40° to +85°C
225MHz +20/21 Dual Modulus Prescaler	MC12019	-40° to +85°C
225MHz +32/33 Dual Modulus Prescaler	MC12015	-40° to +85°C
225MHz +40/41 Dual Modulus Prescaler	MC12016	-40° to +85°C
225MHz +64 Prescaler	MC12023	0° to +75°C
225MHz +64/65 Dual Modulus Prescaler	MC12017	-40° to +85°C
480MHz +5/6 Dual Modulus Prescaler	MC12009	-30° to +85°C
520MHz +128/129 Dual Modulus Prescaler	MC12018	-40° to +85°C
520MHz +64/65 Dual Modulus Prescaler	MC12025	-40° to +85°C
550MHz +10/11 Dual Modulus Prescaler	MC12013	-30° to +85°C
550MHz +8/9 Dual Modulus Prescaler	MC12011	-30° to +85°C
750MHz +2 UHF Prescaler	MC12090	0° to +75°C
2.8GHz +64/128 Low Power Prescaler†	MC12089	-30° to +85°C

**Oscillators**

Crystal Oscillator	MC12061	0° to +75°C
Low Power Voltage Controlled Oscillator	MC12148	-40° to +85°C

**Mixer**

Analog Mixer	MC12002	-30° to +85°C
--------------	---------	---------------

**Detectors**

Phase-Frequency Detector	MC4044	0° to +75°C
Phase-Frequency Detector	MC4344	-55° to +125°C
Phase-Frequency Detector	MC12040	0° to +75°C
Phase-Frequency Detector	MCH12140	-40° to +70°C
Phase-Frequency Detector	MCK12140	-40° to +70°C

**Phase-Locked Loop**

Phase-Locked Loop	MC14046B	-55° to +125°C
-------------------	----------	----------------

**Counters**

Counter Control Logic	MC12014	0° to +75°C
Phase Comparator and Programmable Counter	MC14568B	-55° to +125°C
Programmable Modulo-N Counters (N=0-9)	MC4016	0° to +75°C
Programmable Modulo-N Counters (N=0-9)	MC4018	0° to +75°C
Programmable Modulo-N Counters (N=0-9)	MC4316	-55° to +125°C

**Multivibrators**

130MHz Voltage Controlled Multivibrator	MC12101	0° to +75°C
200 MHz Voltage Controlled Multivibrator	MC12100	0° to +75°C
Dual Voltage-Controlled Multivibrator	MC4024	0° to +75°C
Dual Voltage-Controlled Multivibrator	MC4324	-55° to +125°C

# Selection by Function

Cross-Functional Table

Function	TTL		CMOS			MECL		
	LS	FAST	STD	High Speed	FACT	10K	10H	ECLinPS E-Lite
<b>AND Gates</b>								
Quad 2-Input	08	08	081	08A	08	104	104	
Quad 2-Input, Open-Collector	09							
Triple 3-Input	11	11	073	11	11			
Triple 3-Input, Open-Collector	15							
Dual 4-Input	21	21	082					
Hex						197		
<b>NAND Gates</b>								
Quad 2-Input	00	00	011	00A	00			
Quad 2-Input, Open-Collector	01							
Quad 2-Input, Open-Collector	03			03A				
Quad 2-Input, High-Voltage	26							
Quad 2-Input Buffer	37	37						
Quad 2-Input Buffer, Open-Collector	38	38						
13-Input	133			133				
Triple 3-Input	10	10	023	10	10			
Triple 3-Input, Open-Collector	12							
Dual 4-Input	20	20	012	20	20			
Dual 4-Input, Open-Collector	22							
Dual 4-Input Buffer	40	40						
8-Input	30		068	30				
<b>OR Gates</b>								
Quad 2-Input	32	32	071	32A	32	103	103	
Dual 3-Input 3-Output						110		
High-Speed Dual 3-Input 3-Output						210	210	
Triple 3-Input			075	4075				
Dual 4-Input			072					
<b>NOR Gates</b>								
Quad 2-Input	02	02	001	02A	02	102	102	
Quad 2-Input Buffer	28							
Quad 2-Input Buffer, Open-Collector	33							
Dual 5-Input	260							
Triple 3-Input	27		025	27				
Quad 2-Input With Strobe						100	100	
Triple 4-3-3 Input						106	106	
Dual 3-Input 3-Output						111		
High-Speed Dual 3-Input 3-Output						211	211	
Dual 3-Input, Plus Inverter			000					

3

**Cross-Functional Table** (continued)

Function	TTL		CMOS			MECL		
	LS	FAST	STD	High Speed	FACT	10K	10H	ECLinPS E-Lite

**NOR Gates** (continued)

Dual 4-Input			002	4002				
8-Input			078					

**Exclusive OR Gates**

Quad 2-Input	86	86	070	86	86	113	113	
Quad 2-Input	386							
Quad, Open-Collector	136							

**Exclusive NOR Gates**

Quad, 2-Input Open Drain Output	266		077					
Quad, 2-Input				7266	810			

**Complex Gates**

Quad OR/NOR						101	101	
Triple 2-3-2 Input OR/NOR						105	105	
Triple 2-Input Exclusive OR/Exclusive NOR						107	107	
Dual 4-5 Input OR/NOR						109	109	
Dual 4-5 Input OR/NOR							209	
Dual 2-Wide 2-3 Input OR-AND/OR-AND-Invert						117	117	
Dual 2-Wide 3-Input OR-AND						118	118	
4-Wide 4-3-3-3 Input OR-AND Gate						119	119	
OR-AND/OR-AND-INVERT Gate						121	121	
High-Speed Dual 3-Input 3-Output OR/NOR						212		
Dual 4-Input OR/NOR								
Dual AND-OR-INVERT Gate	51	51	506	51				
3-2-2-3 Input AND-OR-INVERT Gate	54							
2-Wide and 4-Input AND-OR-INVERT Gate	55							
4-2-2-3 Input AND-OR-INVERT Gate		64						
Triple Gate (Dual 4-Input NAND Gate and 2-Input NOR/OR Gate or 8-Input AND/NAND Gate)			501					
4-Bit AND/OR Selector (Quad 2-Channel Data Selector or Quad Exclusive NOR Gate)			519					
Dual 5-Input Majority Logic Gate			530					
Hex Gate (Quad Inverter plus 2-Input NOR Gate plus 2-Input NAND Gate)			572					
2-Wide, 2-Input/2-Wide, 3-Input AND-OR Gate				58				
Quint 2-Input AND-OR								E104 EL04
Quint 2-Input XOR-OR								E107 EL07
Quad Differential AND-NAND								E404 EL05

3

**Cross-Functional Table** (continued)

Function	TTL		CMOS			MECL		
	LS	FAST	STD	High Speed	FACT	10K	10H	ECLinPS E-Lite

**Complex Gates** (continued)

Quad 4-Input OR-NOR								E101 EL01
8-Input OR-NOR				4078				

**Inverters/Buffers (2-State)**

Hex Inverter	04	04	069	04A	04			
Hex Inverter, Open-Collector	05				05			
Dual Complementary Pair Plus Inverter			007					
Hex Buffer, Non-Inverting			050	4050				
Strobed Hex Inverter/Buffer			502					
Hex Buffer With Enable						188	188	
Hex Inverter With Enable						189	189	
Hex Inverter/Buffer			049	4049		195		
Hex Unbuffered Inverter			49U	U04				
9-Bit Buffer								E122
Quad Driver								E112 EL12

**Translators**

Quad TTL to MECL, TTL Strobe						124	124	
Quad TTL to MECL, ECL Strobe							424	
Differential ECL to TTL Translator								ELT25
Quad MECL to TTL						125	125	
Quad PECL to TTL, Single Supply							350	
Quad TTL/NMOS to PECL							351	
Quad CMOS to PECL							352	
TTL or CMOS to CMOS Hex Level Shifter			504					
Quad MST-to-MECL 10,000						190		
Hex MECL 10K to MST Translator						191		
9-Bit TTL-ECL Translator							600	
9-Bit ECL-TTL Translator							601	
9-Bit Latch/TTL-ECL Translator							602	
9-Bit Latch/ECL-TTL Translator							603	
Registered Hex ECL-TTL Translator							605	
Registered Hex PECL-TTL Translator							607	

**Bus-Oriented 3-State Circuits**

Quad Buffer, Low Enable, 3-State	125A	125		125A	125			
Quad Buffer, High Enable, 3-State	126A	126		126A	126			
Octal Bus/Line Driver, Inverting, 3-State	240	240		240	240			
Octal Bus/Line Driver, 3-State	241	241		241	241			
Quad Bus Transceiver, Inverting 3-State	242	242		242				

**3**

**Cross-Functional Table** (continued)

Function	TTL		CMOS			MECL		
	LS	FAST	STD	High Speed	FACT	10K	10H	ECLinPS E-Lite
Quad Bus Transceiver, Noninverting, 3-State	243	243						

**Bus-Oriented 3-State Circuits** (continued)

Octal Driver, Noninverting, 3-State	244	244		244A	244			
Octal Bus Transceiver, Noninverting, 3-State	245	245		245A	245			
Hex Buffer, Common Enable, 3-State	365A	365		365				
Hex Inverter, Common Enable, 3-State	366A	366		366				
Hex Buffer, 4-Bit and 2-Bit, 3-State	367A	367	503	367				
Hex Inverter, 4-Bit and 2-Bit, 3-State	368A	368		368				
Octal Buffer (81LS95), 3-State	795							
Octal Buffer (81LS96), 3-State	796							
Octal Buffer (81LS97), 3-State	797							
Octal Buffer (81LS98), 3-State	798							
Octal Buffer/Line Driver, 3-State	540			540	540			
Octal Buffer/Line Driver, 3-State	541			541	541			
Octal Bus Transceiver, Inverting, 3-State	640	640		640A	640			
Octal Bus Transceiver, Noninverting, 3-State	645							
Octal Transceiver With Storage, 3-State	623	623						
Octal Transceiver/Latch/Multiplexer, Noninverting, 3-State		646		646	646			
Octal Transceiver/Latch/Multiplexer, Inverting, 3-State		648			648			
Dual Latching Bus Driver						128		
Octal Bidirectional Transceiver With 3-State Outputs					620 623 643			
Octal Bus Transceiver/Register Non-Inverting With 3-State Outputs					652			
Octal Registered Transceiver Non-Inverting, With 3-State Outputs		543						
Octal Registered Transceiver Inverting, With 3-State Outputs		544						
Octal Bus Transceiver/Inverting, With 3-State Outputs		620						
Octal Bus Transceiver With Parity Generator Checker, With 3-State Outputs		657A 657B						
Octal Bus Transceiver, Lite Load F245, With 3-State Outputs		1245						
10-Bit Buffer/Line Driver (Non-Inverting), With 3-State Outputs		827						
10-Bit Buffer/Line Driver (Inverting), With 3-State Outputs		828						

3

**Cross-Functional Table** (continued)

Function	TTL		CMOS			MECL		
	LS	FAST	STD	High Speed	FACT	10K	10H	ECLinPS E-Lite

**Bus Drivers (25Ω Outputs)**

Triple 4-3-3 Input						123	123	
Quad Driver/Receiver With 2-1 Output Multiplexer							330	
Dual Driver/Receiver With 4-to-1 Output Multiplexers							332	
Quad Driver/Receiver With Transmit and Receiver Latches							334	
Triple 3-Input Driver With Enable							423	
3-Bit Registered Transceiver								E336
3-Bit Scannable Registered Transceiver								E337

**Transceivers**

Octal Bus, Noninverting, Open-Collector	641							
Octal Bus, Inverting, Open-Collector	642							
Quad Futurebus Backplane, 3-State, Open-Collector		3893A						
Quad TTL-ECL 25Ω Bus Transceiver							680	
6-Bit 50Ω ECL-TTL Transceiver							681	

**Schmitt Triggers**

Quad 2-Input NAND	132	132	093	132A	132			
Dual			583					
Dual 4-Input	13	13						
Hex	14	14	584 106	14A	14			

**Latches**

4-Bit Bi-Stable Latch With Q and $\bar{Q}$	75		042	75				
4-Bit Bi-Stable Latch	77							
Octal Transparent Latch, 3-State, Noninverting	373	373		373A	373			
Quad Latch	375					168		
Quad NAND R-S Latch	279		044					
8-Bit Addressable Latch (9334)	259	259	099	259	259			
Dual 4-Bit Addressable Latch	256	256			256			
Octal Transparent Latch, 3-State				573 563	573 563			
Octal Transparent Latch, 3-State, Inverting		533			533			
Dual Latch						130	130	
Quad (Negative Transition) Latch						133		
Quad (Positive Transition) Latch						153		
Quint Latch						175	175	
Quad NOR R-S Latch			043					
Dual 4-Bit Latch			508					
8-Bit, Bus-Compatible, 3-State Latches, Binary Address			598					
8-Bit Addressable Latch With Bidirectional Port			599					

**3**

**Cross-Functional Table** (continued)

Function	TTL		CMOS			MECL		
	LS	FAST	STD	High Speed	FACT	10K	10H	ECLinPS E-Lite

**Latches** (continued)

6-Bit D								E150
9-Bit With Parity								E175
3-Bit, 4:1 MUX								E256
3-Bit, 4:1 MUX								E156
5-Bit, 2:1 MUX								E154
6-Bit, 2:1 MUX								E155

**Flip-Flops/Registers**

Dual J-K	73A		027	73				
Dual D	74A	74	013	74A	74	131	131	
Dual J-K With Set and Reset	76A					135	135	
Dual J-K With Preset	109A	109		109	109			
Dual J-K With Clear	107A			107				
Dual J-K Edge-Triggered	112A	112		112	112			
Dual J-K Edge-Triggered	113A				113			
Dual J-K Edge-Triggered	114A							
4-Bit D Register, 3-State	173		076	173				
Hex D With Clear	174	174	174	174A	174			
Hex D With Enable	378	378			378			
Quad D With Clear	175	175	175	175	175			
Octal D With Clear	273			273A	273			
Octal D, 3-State	374	374		374A	374			
Octal D With Enable	377	377			377			
4-Bit D With Enable	379	379						
Hex D						176	176	
Hex D Master-Slave With Reset						186	186	
Octal D, Inverting, 3-State				564	564			
Octal D, 3-State		574		574A	574			
High-Speed Dual Type D Master-Slave						231		
Octal D Flip-Flop, 3-State		534		534A	534			
3-Bit Differential D Flip-Flop								E431
4-Bit D Flip-Flop								E131 EL31
6-Bit D Register								E151 EL51
6-Bit D Register, Differential Data and Clock								E451
6-Bit, 2:1 MUX Register								E167

† = New Device

3

**Cross-Functional Table** (continued)

Function	TTL		CMOS			MECL		
	LS	FAST	STD	High Speed	FACT	10K	10H	ECLinPS E-Lite
<b>Flip-Flops/Registers</b> (continued)								
5-Bit Differential D Register								E452 EL52
9-Bit Hold Register								E143
J-K Flip-Flop								EL35
<b>Counters</b>								
Decade	90							
Divide-By-12	92							
4-Bit Binary	93					154		
Decade, Asynchronously Presetable	196							
4-Bit Binary, Asynchronously Presetable	197							
BCD Decade, Asynchronously Reset	160A	160A	160	160	160			
4-Bit Binary, Asynchronous Reset	161A	161A	161	161A	161	178	016	
BCD Decade, Synchronous Reset	162A	162A	162	162	162			
4-Bit Binary, Synchronous Reset	163A	163A	163	163A	163			
Up/Down Decade, With Clear	192		510					
Up/Down Binary, With Clear	193		516					
Up/Down Decade	190				190			
Up/Down Binary	191		029			136	136	
Decade (Divide By 2 and 5)	290					138		
4-Bit Binary	293							
Dual Decade	390		518	390				
Dual 4-Bit Binary	393		520	393				
Dual Decade	490							
Decade Up/Down, 3-State		568						
Binary Up/Down, 3-State	569A	569						
Synchronous 4-Bit Up/Down Binary	669							
Up/Down Decade	168	168						
Up/Down Binary	169	169						
Programmable Decade			522					
Programmable Binary			526					
Universal Decade BCD						137		
Seven-Stage Ripple Counter			024	4024				
Decade Counter/Divider			017	4017				
Presentable Divide-by-N			018					
14-Bit Binary Counter/Divider			060	4060				
12-Bit Binary			040	4040	4040			
14-Bit Binary			020	4020	4020			
Octal Counter/Divider			022					

3



**Cross-Functional Table** (continued)

Function	TTL		CMOS			MECL		
	LS	FAST	STD	High Speed	FACT	10K	10H	ECLinPS E-Lite

**Counters** (continued)

Dual Programmable BCD/Binary			569					
Three-Digit BCD			553					
Real Time 5-Decade			534					
8-Bit Bidirectional Binary Counter, With 3-State Outputs		579 779						
Industrial Time Base Generator			566					
8-Bit Synchronous Binary Up Counter								E016
6-Bit Universal Counter								E136
8-Bit Ripple Counter								E137
8-Bit Bidirectional Binary Counter		269						

**3**

**Register Files**

4 x 4 Register File, Open-Collector	170							
4 x 4 Register File, 3-State	670							
16 X 4-Bit Register File						145	145	

**Shift Registers**

8-Bit Serial-In/Parallel-Out Shift Register	164	164		164				
8-Bit Parallel-In/Serial-Out Shift Register	165		021	165				
4-Bit Shift Register	95B							
8-Bit Parallel-In/Serial-Out Shift Register	166		014					
4-Bit Shift Register	195A	195		195				
4-Bit Universal Shift Register	194A	194	194	194	194	141	141	
8-Bit Shift/Storage Register, 3-State	299	299	094	299	299			
8-Bit Shift Register With Sign Extend, 3-State	322A							
8-Bit Shift/Storage Register, 3-State	323	323			323			
4-Bit Shift Register, 3-State	395							
4-Bit Shifter, With 3-State Outputs		350			350			
18-Bit Static Shift Register			006					
1-to-64 Bit Variable Length Shift Register			557					
Dual 64-Bit Static Shift Register			517					
4-Bit Parallel-In/Parallel-Out Shift Register			035					
Dual 4-Bit Static Shift Register			015					
128-Bit Static Shift Register			562					
8-Bit Parallel to Serial S.R. With Input Latches, 3-State				589				
8-Bit Serial to Parallel S.R. 3-State				595A				
8-Bit Parallel to Serial S.R. With Input Latches				597				
8-Bit Shift Register								E141
9-Bit Shift Register								E142

**Cross-Functional Table** (continued)

Function	TTL		CMOS			MECL		
	LS	FAST	STD	High Speed	FACT	10K	10H	ECLinPS E-Lite
<b>Shift Registers</b> (continued)								
8-Bit Scannable Register								E241
3-Bit Scannable Registered Address Driver								E212
8-Bit Successive Approximation Register			549 559					

**Multiplexers/Data Selectors**

Quad 2-Input Multiplexer, Non-Inverting	157	157A	519	157A	157	158	158	
Quad 2-Input Multiplexer, Inverting	158	158A			158	159	159	
Quad 2-Input Multiplexer, Non-Inverting, 3-State	257B	257A		257	257			
Quad 2-Input Multiplexer, Inverting, 3-State	258B	258A			258			
Quad 2-Multiplexer, With Output Register	298					173	173	
Dual 4-Input Multiplexer	153	153	539	153	153	174	174	
Dual 4-Input Multiplexer, 3-State	253	253		253	253			
8-Input Multiplexer	151	151		151	151	164	164	
8-Input Multiplexer, 3-State	251	251	512	251	251			
Dual 4-Input Multiplexer (Inverting LS153)	352	352			352			
Dual 4-Input Multiplexer (3-State LS352)	353	353			353			
QUAD 2-Input Multiplexer With Output Register	398	398						
Quad 2-Input Multiplexer With Output Register	399	399						
Dual Multiplexer With Latch and Common Reset						132		
Dual Multiplexer With Latch						134		
Quad Analog Switch/Quad Multiplexer			016	4016 4316				
Quad Analog Switch/Quad Multiplexer			066	4066				
Triple 2-Channel Analog Multiplexer/Demultiplexer			053	4053 4353				
Dual 4-Channel Analog Multiplexer/Demultiplexer			052	4052				
Dual 4-Channel Analog Data Selector			529					
Quad 2-Input Analog Multiplexer/Demultiplexer			551					
8-Channel Analog Multiplexer/Demultiplexer			051	4051 4351				
16-Channel Analog Multiplexer/Demultiplexer			067					
4-to-16 Decoder				154				
Quad 2:1 Multiplexer								E157 EL57
5-Bit 2:1 Multiplexer								E158 EL58
3-Bit 4:1 Multiplexer								E171
2-Bit 8:1 Multiplexer								E163
16:1 Multiplexer								E164
Triple Differential 2:1 Multiplexer								E457

3

**Cross-Functional Table** (continued)

Function	TTL		CMOS			MECL		
	LS	FAST	STD	High Speed	FACT	10K	10H	ECLinPS E-Lite

**Decoders/Demultiplexers**

Dual 1-of-4 Decoder/Demultiplexer	139	139		139A	139			
Dual 1-of-4 Decoder (Low)	155		556			171	171	
Dual 1-of-4 Decoder, Open-Collector	156							
1-of-10 Decoder	42			42				
1-of-10 Decoder/Driver, Open-Collector	145							
1-of-8 Decoder/Demultiplexer (Low)	138	138		138A	138	161	161	
3-Line to 8-Line Decoder/Demultiplexer	137			137				
1-of-10 Decoder, 3-State		537						
1-of-8 Decoder, 3-State		538						
Dual 1-of-4 Decoder, 3-State		539						
Binary to 1-8 (High)						162	162	
Dual Binary 1-4 (High)			555			172	172	
BCD-to-Decimal/Binary-to-Octal Decoder			028					
4-Bit Latch/4-to-16 Line Decoder (High)			514	4514				
4-Bit Latch/4-to-16 Line Decoder (Low)			515					
1-of-8 Decoder/Demultiplexer With Latched Inputs				237				

**Display Decode Drivers**

BCD-to-Seven Segment Decoder/Driver, Open-Collector	47							
BCD-to-Seven Segment Decoder/Driver With Pull-Ups	48		558					
BCD-to-Seven Segment Decoder/Driver, Open-Collector	247							
BCD-to-Seven Segment Decoder/Driver With Pull-Ups	248 249							
BCD-to-Seven Segment Latch/Decoder/Driver			511	4511				
BCD-to-Seven Segment Latch/Decoder/Driver Ripple Blanking			513					
BCD-to-Seven Segment Latch/Decoder/Driver			543					
BCD-to-Seven Segment Latch/Decoder/Driver Ripple Blanking			544					
BCD-to-Seven Segment Decoder/Driver, High Current			547					

**Priority Encoders**

10-Line Decimal to 4-Line Priority Encoder	147			147				
8-Input to 3-Line Priority Encoder	148	148	532			165	165	
8-Input to 3-Line Priority Encoder	748							
8-Input to 3-Line Priority Encoder, 3-State	348							
8-Input to 3-Line Priority Encoder, 3-State	848							

**Multivibrators**

Retriggerable Monostable Multivibrator	122					198		
Dual Retriggerable Monostable Multivibrator	123			4538A				

**Cross-Functional Table** (continued)

Function	TTL		CMOS			MECL		
	LS	FAST	STD	High Speed	FACT	10K	10H	ECLinPS E-Lite
<b>Multivibrators</b> (continued)								
Dual One-Shot (Very Stable)	221							
Dual Precision Retrigger/Reset Monostable Multivibrator			538					
<b>Oscillators/Timers</b>								
24-Stage Frequency Divider			521B					
Programmable Timer			536B					
Programmable Oscillator Timer			541B					
Quad Precision Timer/Driver			415					
<b>Receivers</b>								
Triple Line						114		
Quad Line						115	115	
Triple Line						116	116	
High-Speed Triple Line						216		
Quad Bus						129		
Quint Differential Line								E116 EL16
Quint High-Frequency Differential Line								E416
<b>Comparators</b>								
4-Bit Magnitude Comparator	85	85	585	85				
5-Bit Magnitude Comparator						166	166	
8-Bit Magnitude Comparator		521			521			
8-Bit Magnitude Comparator, 3-State	682							
8-Bit Magnitude Comparator, 3-State	684							
8-Bit Magnitude Comparator	688			688				
9-Bit Magnitude Comparator								E166
<b>Arithmetic Operators</b>								
4-Bit Full Adder	83A		008					
4-Bit Full Adder (Rotated LS83A)	283	283						
4-Bit ALU	181	181 381 382				181	181	
4-Bit Barrel Shifter		350			350			
Look Ahead Carry Generator		182					179	
Dual High-Speed Adder/Subtractor							180	
BCD Rate Multiplier			527					
Triple Serial Adder (Negative Logic)			038					
NBCD Adder			560					
9's Complementer			561					
<b>Parity Generator/Checkers</b>								
9-Bit Odd/Even Parity Generator/Checker	280	280		280		170		
12-Bit Parity Generator/Checker			531			160	160	

3

# Numeric Listings

## Special Logic Circuits

### ALExis — Advance Low-Power Expandable Interface Solutions

Device	Function	Pins	DIP	SM
MC16LX543†	16-Bit Latching Transceiver (3-State, Non-Inverting)	64		-1
MC16LX646†	16-Bit Transceiver/Registered Transceiver W/ Multiplexed Outputs (3-State, Non-Inverting)	64		-1
MC16LX952†	-Bit Bidirectional Register With Clock Enable (3-State, Non-Inverting)	64		-1
MC18LX843	18-Bit Transparent Latch With Preset and Reset (3-State, Non-Inverting)	64		-1
MC20LX240	20-Bit Buffer (3-State, Inverting)	64		-1
MC20LX244	20-Bit Buffer (3-State, Non-Inverting)	64		-1
MC20LX245	20-Bit Transceiver (3-State, Non-Inverting)	64		-1
MC20LX373	20-Bit Transparent Latch (3-State, Non-Inverting)	64		-1
MC20LX374	20-Bit D-Type Flip-Flop (3-State, Non-Inverting)	64		-1

† = New Devices

3

### Timing Solutions

Device	Function	Pins	DIP	SM
<b>Clock Drivers</b>				
MC10E111	MC100E111	1:9 Differential Clock Driver With Low Skew, Enable, V <sub>bb</sub>	28	FN
MC10E211	MC100E211	1:6 Differential Clock Distribution Chip	28	FN
MC10EL11	MC100EL11	1:2 Differential Clock Driver	8	D
MC74F803	—	Clock Driver, Quad D-Type Flip-Flop, With Matched Propagation Delays	14	N D
MC74F1803	—	Clock Driver, Quad D-Type Flip-Flop	14	N D
MC10H640	MC100H640	PECL/TTL-TTL Clock Driver (Single @ 5.0V)	28	FN
MC10H641	MC100H641	1-9 PECL-TTL Clock Distribution Chip (Single P.S. @ 5.0V)	28	FN
MC10H642	MC100H642	PECL/TTL-TTL Clock Driver (Similar to H640)	28	FN
MC10H643	MC100H643	1:8 ECL-TTL Clock Distribution Chip (Dual Supply, H641)	28	FN
MC10H644	MC100H644	PECL/TTL-TTL Clock Driver	28	FN
MC10H645	—	1:9 TTL-TTL Clock Distribution Chip	28	FN
MC10H646	MC100H646	1:8 PECL/TTL to TTL Clock Distribution Chip	28	FN
MC88913	—	Low Skew CMOS Clock Driver	14	N D
MC88914	—	Low Skew CMOS Clock Driver With Reset	14	N D
MC88915*55	—	55MHz Low Skew CMOS PLL Clock Driver	28	FN
MC88915*70	—	70MHz Low Skew CMOS PLL Clock Driver	28	FN
MC88915T*55	—	55MHz Low Skew CMOS PLL Clock Driver, 3-State	28	FN
MC88915T*70	—	70MHz Low Skew CMOS PLL Clock Driver, 3-State	28	FN
MC88915T*100	—	100MHz Low Skew CMOS PLL Clock Driver, 3-State	28	FN
MC88915T*133†	—	133MHz Low Skew CMOS PLL Clock Driver, 3-State	28	FN
MC88915T*160†	—	160MHz Low Skew CMOS PLL Clock Driver, 3-State	28	FN
MC88916*70	—	70MHz Low Skew CMOS PLL Clock Driver With Processor Reset	20	DW
MC88916*80	—	80MHz Low Skew CMOS PLL Clock Driver With Processor Reset	20	DW
MC88920	—	50MHz Low Skew CMOS PLL Clock Driver With Power-Up/Down	20	DW
MC8892†	—	66MHz Low Skew CMOS PLL Clock Driver With Power-Up/Down	20	DW

\* ≤ 20-Pin DIP = 20-Pin PLCC; > 20-Pin DIP = 28-Pin PLCC; See Conversion Table on page 3.1-62

† = New Devices

## Timing Solutions

Device	Function	Pins	DIP	SM
<b>Programmable Delay Chips</b>				
MC10E195	MC100E195	Programmable Delay Chip (Digitally Selectable 20ps Res)	28	FN
MC10E196	MC100E196	Programmable Delay Chip (Dig 20ps Anal. < Ips)	28	FN

\* ≤ 20-Pin DIP = 20-Pin PLCC; > 20-Pin DIP = 28-Pin PLCC; See Conversion Table on page 3.1-62

† = New Devices

## Translators

Device	Function	Pins	DIP	SM
MC10124	—	Quad TTL-to-MECL Translator	16	P,L FN
MC10125	—	Quad MECL-to-TTL Translator	16	P,L FN
MC10177	—	Triple MECL-to-NMOS Translator	16	L
MC10190	—	Quad MST-to-MECL 10K Translator	16	P,L FN
MC14504B	—	Hex TTL OR CMOS to CMOS Hex Level Shifter	16	P,L D
MC10H124	—	Quad TTL-to-MECL Translator	16	P,L FN
MC10H125	—	Quad MECL-to-TTL Translator	16	P,L FN
MC10H350	—	PECL-to-TTL Translator (Single P.S. @ + 5.0V)	16	P,L FN
MC10H351	—	Quad TTL/NMOS-to-PECL Translator (Single P.S. @ + 5.0V)	20	P,L FN
MC10H352	—	Quad CMOS-to-PECL Translator (Single P.S. @ + 5.0V)	20	P,L FN
MC10H424	—	Quad TTL-to-ECL Translator (ECL Strobe)	16	P,L FN
MC10H600	MC100H600	9-Bit TTL-ECL Translator	28	FN
MC10H601	MC100H601	9-Bit ECL-TTL Translator	28	FN
MC10H602	MC100H602	9-Bit Latch/TTL-ECL Translator	28	FN
MC10H603	MC100H603	9-Bit Latch/ECL-TTL Translator	28	FN
MC10H604	MC100H604	Registered HEX TTL-ECL Translator	28	FN
MC10H605	MC100H605	Registered Hex ECL-TTL Translator	28	FN
MC10H606	MC100H606	Registered Hex TTL-PECL Translator	28	FN
MC10H607	MC100H607	Registered Hex PECL-TTL Translator	28	FN
MC10ELT25†	MC100ELT25†	Differential ECL-to-TTL Translator	8	D

\* ≤ 20-Pin DIP = 20-Pin PLCC; > 20-Pin DIP = 28-Pin PLCC; See Conversion Table on page 3.1-62

† = New Devices

## CBM

Device	Function	Pins	DIP	SM
MC68194	CBM - Carrier Band Modem	52		FJ**

\*\*FJ = Ceramic Leadless Chip Carrier (CLCC)

## SCSI Bus Terminator

Device	Function	Pins	DIP	SM
MCCS142233	9-Bit Switchable Passive SCSI Bus Term (220Ω & 330Ω)	20		FN
MCCS142234	9-Bit Switchable Active SCSI Bus Term (110Ω)	16		D
MCCS142235	18-Bit Active SCSI Bus Terminator (Also Available in 32-Pin QFP Package)	24		DW, F, A

## Memory Support

Device	Function	Pins	DIP	SM
MC10H660	MC100H660	Quad Dual Output ECL-TTL DRAM Driver With Latch	28	FN

### Industrial Control Unit

Device	Function	Pins	DIP	SM
MC14500B	Industrial Control Unit	16	P,L	DW

### Bounce Eliminator

Device	Function	Pins	DIP	SM
MC14490	Hex Contact Bounce Eliminator	16	P,L	DW

### Phase-Locked Loop

Device	Function	Pins	DIP	SM
MC4016	Programmable Modulo-N Counters (N=0-9)	16	P,L	
MC4018	Programmable Modulo-N Counters (N=0-9)	16	P,L	
MC4024	Dual Voltage-Controlled Multivibrator	14	P,L	
MC4044	Phase-Frequency Detector	14	P,L	
MC4316	Programmable Modulo-N Counters (N=0-9)	16	P,L	
MC4324	Dual Voltage-Controlled Multivibrator	14	P,L	
MC4344	Phase-Frequency Detector	14	P,L	
MC12002	Analog Mixer	14	P,L	
MC12009	480MHz +5/6 Dual Modulus Prescaler	16	P,L	
MC12011	550MHz +8/9 Dual Modulus Prescaler	16	P,L	
MC12013	550MHz +10/11 Dual Modulus Prescaler	16	P,L	
MC12014	Counter Control Logic	16	P,L	
MC12015	225MHz +32/33 Dual Modulus Prescaler	8	P,L	D
MC12016	225MHz +40/41 Dual Modulus Prescaler	8	P,L	D
MC12017	225MHz +64/65 Dual Modulus Prescaler	8	P,L	D
MC12018	520MHz +128/129 Dual Modulus Prescaler	8	P,L	D
MC12019	225MHz +20/21 Dual Modulus Prescaler	8	P,L	D
MC12022A	1.1GHz +64/65, +128/129 Dual Modulus Prescaler	8	P	D
MC12022B	1.1GHz +64/65, +128/129 Dual Modulus Prescaler	8	P	D
MC12022LVA	1.1GHz +64/65, +128/129 Low Voltage Dual Modulus Prescaler	8	P	D
MC12022LVB	1.1GHz +64/65, +128/129 Low Voltage Dual Modulus Prescaler	8	P	D
MC12022SLA	1.1GHz +64/65, +128/129 Dual Modulus Prescaler	8	P	D
MC12022SLB	1.1GHz +64/65, +128/129 Dual Modulus Prescaler	8	P	D
MC12022TSA	1.1GHz +64/65, +128/129 Dual Modulus Prescaler	8	P	D
MC12022TSB	1.1GHz +64/65, +128/129 Dual Modulus Prescaler	8	P	D
MC12022TVB	1.1GHz +64/65, +128/129 Low Voltage Dual Modulus Prescaler	8	P	D
MC12022TVA	1.1GHz +64/65, +128/129 Low Voltage Dual Modulus Prescaler	8	P	D
MC12023	225MHz +64 Prescaler	8	P	D
MC12025	520MHz +64/65 Dual Modulus Prescaler	8	P	D
MC12026A	1.1GHz +8/9, +16/17 Dual Modulus Prescaler	8	P	D
MC12026B	1.1GHz +8/9, +16/17 Dual Modulus Prescaler	8	P	D
MC12028A	1.1GHz +32/33, +64/65 Dual Modulus Prescaler	8	P	D
MC12028B	1.1GHz +32/33, +64/65 Dual Modulus Prescaler	8	P	D
MC12031A	2.0GHz +64/65, +128/129 Low Voltage Dual Modulus Prescaler	8	P	D
MC12031B	2.0GHz +64/65, +128/129 Low Voltage Dual Modulus Prescaler	8	P	D

3

**Phase-Locked Loop** (continued)

Device	Function	Pins	DIP	SM
MC12032A	2.0GHz +64/65, +128/129 Dual Modulus Prescaler	8	P	D
MC12032B	2.0GHz +64/65, +128/129 Dual Modulus Prescaler	8	P	D
MC12033A	2.0GHz +32/33, +64/65 Low Voltage Dual Modulus Prescaler	8	P	D
MC12033B	2.0GHz +32/33, +64/65 Low Voltage Dual Modulus Prescaler	8	P	D
MC12034A	2.0GHz +32/33, +64/65 Dual Modulus Prescaler	8	P	D
MC12034B	2.0GHz +32/33, +64/65 Dual Modulus Prescaler	8	P	D
MC12036A	1.1GHz +64/65, +128/129 Dual Modulus Prescaler with Stand-By Mode	8	P	D
MC12036B	1.1GHz +64/65, +128/129 Dual Modulus Prescaler with Stand-By Mode	8	P	D
MC12040	Phase-Frequency Detector	14	P,L	FN
MC12061	Crystal Oscillator	16	P,L	
MC12073	1.1GHz +64 Prescaler	8	P	D
MC12074	1.1GHz +256 Prescaler	8	P	D
MC12076	1.3GHz +256 Prescaler	8	P	D
MC12078	1.3GHz +256 Prescaler	8	P	D
MC12079	2.8GHz +64/128/256 Prescaler	8	P	D
MC12080	1.1GHz +10/20/40/80 Prescaler	8	P	D
MC12083	1.1GHz +2 Low Power Prescaler with Stand-By Mode	8	P	D
MC12089†	2.8GHz +64/128 Low Power Prescaler	8		
MC12090	750MHz +2 UHF Prescaler	16	P,L	
MC12100	200MHz Voltage Controlled Multivibrator	20	P	FN
MC12101	130MHz Voltage Controlled Multivibrator	20	P	FN
MCH12140	Phase-Frequency Detector	8		D
MCK12140	Phase-Frequency Detector	8		D
MC12148	Low Power Voltage Controlled Oscillator	8	P	D

**3**



# Numeric Listings

## TTL Overview

Since its introduction, TTL has become the most popular form of digital logic. It has evolved from the original gold-doped saturated 7400 logic, to Schottky-Clamped logic, and finally to the modern advanced families of TTL logic. The popularity of these TTL families stems from their ease of use, low cost, medium-to-high speed operation, and good output drive capability.

Motorola offers two modern TTL logic families — LS and FAST. They are pin and functionally compatible and can easily be combined in a system to achieve maximum performance at minimum cost.

LS (Low Power Schottky) is currently the more popular and commands by far the largest share of the total TTL logic market. It is low-cost and provides moderate performance at low power.

FAST, the state-of-the-art, high-performance TTL family, is growing rapidly and gaining a significant share of the total TTL logic market. FAST offers a 20–30 percent improvement in performance over the older Standard Schottky family (74S) with a 75–80 percent reduction in power. When compared with the Advanced Schottky family (74AS), FAST offers nearly equal performance at a 25–50 percent savings in power.

FAST is manufactured on Motorola's MOSAIC

(oxide-isolated) process. This process provides FAST with inherent speed/power advantages over the older junction-isolated 74S and 74LS families. This allows the FAST family to be designed and specified with improved noise margins, reduced input currents, and superior line driving capabilities in comparison to these earlier families. Additionally, FAST designs incorporate power-down circuitry on all three-state outputs, and buffered outputs on all storage devices.

Two further advantages of FAST are the load specifications and power supply specifications. FAST ac characteristics are specified at a heavier capacitive load than the earlier families (50 pF versus 15 pF) to more accurately reflect actual in-circuit performance. Motorola's DC and AC characteristics for FAST are specified over a full 10% supply voltage range — a significant improvement over the industry standard specifications for the earlier families (5% for DC, 0% for AC).

These design and specification improvements offered by the Motorola FAST family provide the user with better system performance, enhanced design flexibility, and more reliable system operation.

3

## TTL Family Comparisons

General Characteristics for Schottky TTL Logic (All Maximum Ratings)

Characteristic	Symbol	LS		FAST		Unit
		54LSxxx	74LSxxx	54Fxxx	74Fxxx	
Operating Voltage Range	V <sub>CC</sub>	5 ± 10%	5 ± 5%	5 ± 10%	5 ± 10%	V <sub>dc</sub>
Operating Temperature Range	T <sub>A</sub>	-55 to 125	0 to 70	-55 to 125	0 to 70	°C
Input Current	I <sub>IN</sub>	20 -400	20 -400	20 -600	20 -600	μA
Output Drive Standard Output	I <sub>OH</sub>	-0.4	-0.4	-1.0	-1.0	mA
	I <sub>OL</sub>	4.0	8.0	20	20	mA
	I <sub>SC</sub>	-20 to -100	-20 to -100	-60 to -150	-60 to -150	mA
Buffer Output	I <sub>OH</sub>	-12	-15	-12	-15	mA
	I <sub>OL</sub>	12	24	48	64	mA
	I <sub>SC</sub>	-40 to -225	-40 to -225	-100 to -225	-100 to -225	mA

Speed/Power Characteristics for Schottky TTL Logic<sup>(1)</sup> (All Typical Ratings)

Characteristic	Symbol	LS	FAST	Unit	Characteristic	Symbol	LS	FAST	Unit	
Quiescent Supply Current/Gate	I <sub>G</sub>	0.4	1.1	mA	Speed Power Product	—	18	19.2	pJ	
Power/Gate (Quiescent)	P <sub>G</sub>	2.0	5.5	mW		Clock Frequency (D-F/F)	f <sub>max</sub>	33	125	MHz
Propagation Delay	t <sub>p</sub>	9.0	3.7	ns		Clock Frequency (Counter)	f <sub>max</sub>	40	125	MHz

<sup>(1)</sup> Specifications are shown for the following conditions: a) V<sub>CC</sub> = 5.0 Vdc; b) T<sub>A</sub> = 25°C and c) C<sub>L</sub> = 50 pF for FAST; 15 pF for LS.

## LS — Low Power Schottky

### Numeric Listing

Device		Function	Pins	DIP	SM
SN54LS00	SN74LS00	Quad 2-Input NAND Gate	14	N,J	D
SN54LS01	SN74LS01	Quad 2-Input NAND Gate	14	N,J	D
SN54LS02	SN74LS02	Quad 2-Input NOR Gate	14	N,J	D
SN54LS03	SN74LS03	Quad 2-Input NAND Gate	14	N,J	D
SN54LS04	SN74LS04	Hex Inverter	14	N,J	D
SN54LS05	SN74LS05	Hex Inverter	14	N,J	D
SN54LS08	SN74LS08	Quad 2-Input AND Gate	14	N,J	D
SN54LS09	SN74LS09	Quad 2-Input AND Gate	14	N,J	D
SN54LS10	SN74LS10	Triple 3-Input NAND Gate	14	N,J	D
SN54LS11	SN74LS11	Triple 3-Input AND Gate	14	N,J	D
SN54LS12	SN74LS12	Triple 3-Input NAND Gate	14	N,J	D
SN54LS13	SN74LS13	Dual 4-Input NAND Schmitt Trigger	14	N,J	D
SN54LS14	SN74LS14	Hex Inverter Schmitt Trigger	14	N,J	D
SN54LS15	SN74LS15	Triple 3-Input AND Gate	14	N,J	D
SN54LS20	SN74LS20	Dual 4-Input NAND Gate	14	N,J	D
SN54LS21	SN74LS21	Dual 4-Input AND Gate	14	N,J	D
SN54LS22	SN74LS22	Dual 4-Input NAND Gate	14	N,J	D
SN54LS26	SN74LS26	Quad 2-Input NAND Buffer	14	N,J	D
SN54LS27	SN74LS27	Triple 3-Input NOR Gate	14	N,J	D
SN54LS28	SN74LS28	Quad 2-Input NOR Buffer	14	N,J	D
SN54LS30	SN74LS30	8-Input NAND Gate	14	N,J	D
SN54LS32	SN74LS32	Quad 2-Input OR Gate	14	N,J	D
SN54LS33	SN74LS33	Quad 2-Input NOR Buffer	14	N,J	D
SN54LS37	SN74LS37	Quad 2-Input NAND Buffer	14	N,J	D
SN54LS38	SN74LS38	Quad 2-Input NAND Buffer Open-Collector	14	N,J	D
SN54LS40	SN74LS40	Dual 4-Input NAND Buffer	14	N,J	D
SN54LS42	SN74LS42	One-of-Ten Decoder	16	N,J	D
SN54LS47	SN74LS47	Binary-Coded-Decimal to 7 Segment Decoder/Driver	16	N,J	D
SN54LS48	SN74LS48	Binary-Coded-Decimal to 7 Segment Decoder	16	N,J	D
SN54LS51	SN74LS51	Dual 2 Wide 2-Input/3-Input AND/OR Invert Gate	14	N,J	D
SN54LS54	SN74LS54	3-2-2-3-Input AND/OR Invert Gate	14	N,J	D
SN54LS55	SN74LS55	2-Wide, 4-Input AND/OR Invert Gate	14	N,J	D
SN54LS73A	SN74LS73A	Dual J-K Negative Edge-Triggered Flip-Flop	14	N,J	D
SN54LS74A	SN74LS74A	Dual D-Type Positive Edge-Triggered Flip-Flop	16	N,J	D
SN54LS75	SN74LS75	4-Bit D Latch	16	N,J	D
SN54LS76A	SN74LS76A	Dual J-K Flip-Flop With Set and Clear	16	N,J	D
SN54LS77	SN74LS77	4-Bit D Latch	14	N,J	D
SN54LS83A	SN74LS83A	4-Bit Binary Full Adder With Fast Carry	14	N,J	D
SN54LS85	SN74LS85	4-Bit Magnitude Comparator	16	N,J	D
SN54LS86	SN74LS86	Quad Exclusive OR Gate	14	N,J	D

3

## LS — Low Power Schottky (continued)

### Numeric Listing (continued)

Device		Function	Pins	DIP	SM
SN54LS90	SN74LS90	Decade Counter	14	N,J	D
SN54LS92	SN74LS92	Divide By 12 Counter	14	N,J	D
SN54LS93	SN74LS93	4–Bit Binary Counter	14	N,J	D
SN54LS95B	SN74LS95B	4–Bit Shift Register	14	N,J	D
SN54LS107A	SN74LS107A	Dual J–K Flip–Flop	14	N,J	D
SN54LS109A	SN74LS109A	Dual J–K Positive Edge–Triggered Flip–Flop	16	N,J	D
SN54LS112A	SN74LS112A	Dual J–K Negative Edge–Triggered Flip–Flop	16	N,J	D
SN54LS113A	SN74LS113A	Dual J–K Negative Edge–Triggered Flip–Flop	14	N,J	D
SN54LS114A	SN74LS114A	Dual J–K Negative Edge–Triggered Flip–Flop	14	N,J	D
SN54LS122	SN74LS122	Retriggerable Monostable Multivibrators	14	N,J	D
SN54LS123	SN74LS123	Retriggerable Monostable Multivibrators	14	N,J	D
SN54LS125A	SN74LS125A	Quad Buffers With 3–State Outputs	14	N,J	D
SN54LS126A	SN74LS126A	Quad Buffers With 3–State Outputs	14	N,J	D
SN54LS132	SN74LS132	Quad 2–Input Schmitt Trigger NAND Gate	14	N,J	D
SN54LS133	SN74LS133	13–Input NAND Gate	16	N,J	D
—	SN74LS136	Quad 2–Input Exclusive OR Gate	14	N,J	D
SN54LS137	SN74LS137	3–Line to 8–Line Decoders/Demultiplexers With Address Latches	16	N,J	D
SN54LS138	SN74LS138	1–of–8 Decoder/Demultiplexer	16	N,J	D
SN54LS139	SN74LS139	Dual 1–of–4 Decoder/Demultiplexer	16	N,J	D
SN54LS145	SN74LS145	1–of–10 Decoder/Driver Open–Collector	16	N,J	D
SN54LS147	SN74LS147	10–Line to 4–Line Priority Encoder	16	N,J	D
SN54LS148	SN74LS148	8–Line to 3–Line Priority Encoder	16	N,J	D
SN54LS151	SN74LS151	8–Input Multiplexer	16	N,J	D
SN54LS153	SN74LS153	Dual 4–Input Multiplexer	16	N,J	D
SN54LS155	SN74LS155	Dual 1–of–4 Decoder	16	N,J	D
SN54LS156	SN74LS156	Dual 1–of–4 Decoder Open–Collector	16	N,J	D
SN54LS157	SN74LS157	Quad 2–Input Multiplexer	16	N,J	D
SN54LS158	SN74LS158	Quad 2–Input Multiplexer	16	N,J	D
SN54LS160A	SN74LS160A	4–Bit BCD Decade Counter, Asynchronous Reset	16	N,J	D
SN54LS161A	SN74LS161A	4–Bit Binary Counter, Synchronous Reset	16	N,J	D
SN54LS162A	SN74LS162A	4–Bit BCD Decade Counter, Asynchronous Reset	16	N,J	D
SN54LS163A	SN74LS163A	4–Bit Binary Counter, Synchronous Reset	16	N,J	D
SN54LS164	SN74LS164	8–Bit Serial–In Parallel–Out Shift Register	14	N,J	D
SN54LS165	SN74LS165	8–Bit Parallel–to–Serial Converter	16	N,J	D
SN54LS166	SN74LS166	8–Bit Shift Registers	16	N,J	D
SN54LS168	SN74LS168	BCD Decade Synchronous Bidirectional Counter	16	N,J	D
SN54LS169	SN74LS169	Modulo 16 Binary Synchronous Bidirectional Counter	16	N,J	D
SN54LS170	SN74LS170	4 X 4 Register File Open Collector	16	N,J	D
SN54LS173A	SN74LS173A	4–Bit D–Type Register With 3–State Outputs	16	N,J	D
SN54LS174	SN74LS174	Hex D Flip–Flop	16	N,J	D

3

## LS — Low Power Schottky (continued)

### Numeric Listing (continued)

Device		Function	Pins	DIP	SM
SN54LS175	SN74LS175	Quad D Flip-Flop	16	N,J	D
SN54LS181	SN74LS181	4-Bit Arithmetic Logic Unit	24	N,J	DW
SN54LS190	SN74LS190	Presetable BCD/Decade Up/Down Counter	16	N,J	D
SN54LS191	SN74LS191	Presetable 4-Bit Binary Up/Down Counter	16	N,J	D
SN54LS192	SN74LS192	Presetable BCD/Decade Up/Down Counter	16	N,J	D
SN54LS193	SN74LS193	Presetable 4-Bit Binary Up/Down Counter	16	N,J	D
SN54LS194A	SN74LS194A	4-Bit Bidirectional Universal Shift Register	16	N,J	D
SN54LS195A	SN74LS195A	Universal 4-Bit Shift Register	16	N,J	D
SN54LS196	SN74LS196	4-Stage Presetable Ripple Counters	14	N,J	D
SN54LS197	SN74LS197	4-Stage Presetable Ripple Counters	14	N,J	D
SN54LS221	SN74LS221	Dual Monostable Multivibrators With Schmitt Trigger Inputs	16	N,J	D
SN54LS240	SN74LS240	Octal Buffer/Line Driver With 3-State Outputs	20	N,J	DW
SN54LS241	SN74LS241	Octal Buffer/Line Driver With 3-State Outputs	20	N,J	DW
SN54LS242	SN74LS242	Quad Bus Transceiver/Inverting With 3-State Outputs	14	N,J	D
SN54LS243	SN74LS243	Quad Bus Transceiver/Non-Inverting With 3-State Outputs	14	N,J	D
SN54LS244	SN74LS244	Octal Buffer/Line Driver With 3-State	20	N,J	DW
SN54LS245	SN74LS245	Octal Bus Transceiver	20	N,J	DW
SN54LS247	SN74LS247	BCD-to-Seven-Segment Decoders/Drivers	16	N,J	D
SN54LS248	SN74LS248	BCD-to-Seven-Segment Decoders/Drivers	16	N,J	D
SN54LS249	SN74LS249	BCD-to-Seven-Segment Decoders/Drivers	16	N,J	D
SN54LS251	SN74LS251	8-Input Multiplexer With 3-State Outputs	16	N,J	D
SN54LS253	SN74LS253	Dual 4-Input Multiplexer With 3-State Outputs	16	N,J	D
SN54LS256	SN74LS256	Dual 4-Bit Addressable Latch	16	N,J	D
SN54LS257B	SN74LS257B	Quad 2-Input Multiplexer With 3-State Outputs	16	N,J	D
SN54LS258B	SN74LS258B	Quad 2-Input Multiplexer, Inverting, With 3-State Outputs	16	N,J	D
SN54LS259	SN74LS259	8-Bit Addressable Latch	16	N,J	D
SN54LS260	SN74LS260	Dual 5-Input NOR Gate	14	N,J	D
SN54LS266	SN74LS266	Quad 2-Input Exclusive NOR Gate	14	N,J	D
SN54LS273	SN74LS273	Octal D Flip-Flop With Clear	20	N,J	DW
SN54LS279	SN74LS279	Quad Set/Reset Latch	16	N,J	D
SN54LS280	SN74LS280	9-Bit Odd/Even Parity Generator/Checker	14	N,J	D
SN54LS283	SN74LS283	4-Bit Binary Full Adder With Fast Carry	16	N,J	D
SN54LS290	SN74LS290	Decade Counter	14	N,J	D
SN54LS293	SN74LS293	4-Bit Binary Counter	14	N,J	D
SN54LS298	SN74LS298	Quad 2-Input Multiplexer With Storage	16	N,J	D
SN54LS299	SN74LS299	8-Bit Shift/Storage Register With 3-State Outputs	20	N,J	DW
SN54LS322A	SN74LS322A	8-Bit Shift Registers With Sign Extend	20	N,J	DW
SN54LS323	SN74LS323	8-Bit Shift/Storage Register With 3-State Outputs	20	N,J	DW
SN54LS348	SN74LS348	8-Input Priority Encoder	16	N,J	D
SN54LS352	SN74LS352	Dual 4-Input Multiplexer	16	N,J	D

3

## LS — Low Power Schottky (continued)

### Numeric Listing (continued)

Device		Function	Pins	DIP	SM
SN54LS353	SN74LS353	Dual 4-Input Multiplexer With 3-State Outputs	16	N,J	D
SN54LS365A	SN74LS365A	Hex Buffer Gated Enable Non-Inverting With 3-State Outputs	16	N,J	D
SN54LS366A	SN74LS366A	Hex Buffer Gated Enable Inverting With 3-State Outputs	16	N,J	D
SN54LS367A	SN74LS367A	Hex Buffer 4/2-Bit/Non-Inverting With 3-State Outputs	16	N,J	D
SN54LS368A	SN74LS368A	Hex Buffer 4/2-Bit/Inverting With 3-State Outputs	16	N,J	D
SN54LS373	SN74LS373	Octal Transparent Latch With 3-State Outputs	20	N,J	DW
SN54LS374	SN74LS374	Octal D-Type Flip-Flop With 3-State Outputs	20	N,J	DW
SN54LS375	SN74LS375	4-Bit D Latch	16	N,J	D
SN54LS377	SN74LS377	Octal D Flip-Flop With Enable/ Non-Inverting	20	N,J	DW
SN54LS378	SN74LS378	Hex D Flip-Flop With Enable	16	N,J	D
SN54LS379	SN74LS379	4-Bit D Flip-Flop With Enable	16	N,J	D
SN54LS386	SN74LS386	Quad 2-Input Exclusive OR Gate	14	N,J	D
SN54LS390	SN74LS390	Dual Decade Counter	16	N,J	D
SN54LS393	SN74LS393	Dual 4-stage Binary Counter	16	N,J	D
—	SN74LS395	4-Bit Shift Register With 3-State Outputs	16	N,J	D
SN54LS398	SN74LS398	Quad 2-Port Register	20	N,J	DW
SN54LS399	SN74LS399	Quad 2-Port Register	20	N,J	DW
SN54LS490	SN74LS490	Dual Decade Counter	16	N,J	D
SN54LS540	SN74LS540	Octal Buffer/Line Driver With 3-State Outputs	20	N,J	DW
SN54LS541	SN74LS541	Octal Buffer/Line Driver With 3-State Outputs	20	N,J	DW
SN54LS569A	SN74LS569A	4-Bit Up/Down Counter With 3-State Outputs	20	N,J	DW
SN54LS623	SN74LS623	Octal Bus Transceiver	20	N,J	DW
SN54LS640	SN74LS640	Octal Bus Transceiver/Inverting With 3-State Outputs	20	N,J	DW
SN54LS641	SN74LS641	Octal Bus Transceiver/Non-Inverting With Open Collector	20	N,J	DW
SN54LS642	SN74LS642	Octal Bus Transceiver/Inverting With Open Collector	20	N,J	DW
SN54LS645	SN74LS645	Octal Bus Transceiver/Non-Inverting With 3-State Outputs	20	N,J	DW
SN54LS669	SN74LS669	Synchronous 4-Bit Up/Down Counter	16	N,J	D
SN54LS670	SN74LS670	4 X 4 Register File With 3-State Outputs	16	N,J	D
SN54LS682	SN74LS682	8-Bit Magnitude Comparators	20	N,J	DW
SN54LS684	SN74LS684	8-Bit Magnitude Comparators	20	N,J	DW
SN54LS688	SN74LS688	8-Bit Magnitude Comparators	20	N,J	DW
SN54LS748	SN74LS748	8-Line to 3-Line Priority Encoder	16	N,J	D
SN54LS795	SN74LS795	Octal Buffer (81LS95), With 3-State Outputs	20	N,J	DW
SN54LS796	SN74LS796	Octal Buffer (81LS96), With 3-State Outputs	20	N,J	DW
SN54LS797	SN74LS797	Octal Buffer (81LS97), With 3-State Outputs	20	N,J	DW
SN54LS798	SN74LS798	Octal Buffer (81LS98), With 3-State Outputs	20	N,J	DW
SN54LS848	SN74LS848	8-Input Priority Encoder (Glitchless)	16	N,J	D

3

**FAST****Numeric Listing**

Device	Function	Pins	DIP	SM
MC74F00	Quad 2-Input NAND Gate	14	N	D
MC74F02	Quad 2-Input NOR Gate	14	N	D
MC74F04	Hex Inverter	14	N	D
MC74F08	Quad 2-Input AND Gate	14	N	D
MC74F10	Triple 3-Input NAND Gate	14	N	D
MC74F11	Triple 3-Input AND Gate	14	N	D
MC74F13	Dual 4-Input NAND Schmitt Trigger	14	N	D
MC74F14	Hex Inverter Schmitt Trigger	14	N	D
MC74F20	Dual 4-Input NAND Gate	14	N	D
MC74F21	Dual 4-Input AND Gate	14	N	D
MC74F32	Quad 2-Input OR Gate	14	N	D
MC74F37	Quad 2-Input NAND Buffer	14	N	D
MC74F38	Quad 2-Input NAND Buffer Open-Collector	14	N	D
MC74F40	Dual 4-Input NAND Buffer	14	N	D
MC74F51	Dual 2-Wide 2-Input, 2-Wide 3-Input AND-OR-Invert Gate	14	N	D
MC74F64	4-2-3-2 Input AND-OR-Invert Gate	14	N	D
MC74F74	Dual D-Type Positive Edge-Triggered Flip-Flop	14	N	D
MC74F85	4-Bit Magnitude Comparator	16	N	D
MC74F86	Quad 2-Input Exclusive OR Gate	14	N	D
MC74F109	Dual JK(bar) Positive Edge-Triggered Flip-Flop	16	N	D
MC74F112	Dual J-K Negative Edge-Triggered Flip-Flop	16	N	D
MC74F125	Quad Buffer, With 3-State Outputs	14	N	D
MC74F126	Quad Buffer, With 3-State Outputs	14	N	D
MC74F132	Quad 2-Input NAND Schmitt Trigger	14	N	D
MC74F138	1-of-8 Decoder/Demultiplexer	16	N	D
MC74F139	Dual 1-of-4 Decoder/Demultiplexer	16	N	D
MC74F148	8-Line to 3-Line Priority Encoder	16	N	D
MC74F151	8-Input Multiplexer	16	N	D
MC74F153	Dual 4-Input Multiplexer	16	N	D
MC74F157A	Quad 2-Input Multiplexer	16	N	D
MC74F158A	Quad 2-Input Multiplexer	16	N	D
MC74F160A	BCD Decade Counter, Synchronous Presettable	16	N	D
MC74F161A	Binary Counter, Synchronous Presettable, 4-Bit	16	N	D
MC74F162A	BCD Decade Counter, Synchronous Presettable	16	N	D
MC74F163A	Binary Counter, Synchronous Presettable, 4-Bit	16	N	D
MC74F164	8-Bit Serial In-Serial Out Shift Register	14	N	D
MC74F168	4-Stage Synchronous Bidirectional Counter	16	N	D
MC74F169	4-Stage Synchronous Bidirectional Counter	16	N	D
MC74F174	Hex D Flip-Flop With Master Reset	16	N	D
MC74F175	Quad D Flip-Flop	16	N	D

**3**

**FAST** (continued)**Numeric Listing** (continued)

Device	Function	Pins	DIP	SM
MC74F181	4–Bit Arithmetic Logic Unit	24	N	DW
MC74F182	Carry Lookahead Generator	16	N	D
MC74F194	4–Bit Bidirectional Universal Shift Register	16	N	D
MC74F195	4–Bit Shift Register	16	N	D
MC74F240	Octal Buffer/Line Driver With 3–State Outputs	20	N	DW
MC74F241	Octal Buffer/Line Driver With 3–State Outputs	20	N	DW
MC74F242	Quad Bus Transceivers With 3–State Outputs	14	N	D
MC74F243	Quad Bus Transceivers With 3–State Outputs	14	N	D
MC74F244	Octal Buffer/Line Driver With 3–State Outputs	20	N	DW
MC74F245	Octal Bidirectional Transceiver With 3–State Outputs	20	N	DW
MC74F251	8–Input Multiplexer, With 3–State Outputs	16	N	D
MC74F253	Dual 4–Input Multiplexer, With 3–State Outputs	16	N	D
MC74F256	Dual 4–Bit Addressable Latch	16	N	D
MC74F257A	Quad 2–Input Multiplexer, With 3–State Outputs	16	N	D
MC74F258A	Quad 2–Input Multiplexer, With 3–State Outputs	16	N	D
MC74F259	8–Bit Addressable Latch	16	N	D
MC74F269	8–Bit Bidirectional Binary Counter	24	N	DW
MC74F280	9–Bit Parity Generator/Checker	14	N	D
MC74F283	4–Bit Binary Full Adder (With Fast Carry)	16	N	D
MC74F299	8–Input Universal Shift/Storage Register, With Common Parallel I/O Pins	20	N	DW
MC74F323	8–Input Shift/Storage Register With Sync Reset and Common I/O Pins	20	N	DW
MC74F350	4–Bit Shifter, With 3–State Outputs	16	N	D
MC74F352	Dual 4–Input Multiplexer	16	N	D
MC74F353	Dual 4–Input Multiplexer, With 3–State Outputs	16	N	D
MC74F365	Hex Buffer/Driver Gated Enable Non–Inverting, With 3–State Outputs	16	N	D
MC74F366	Hex Buffer/Driver Gated Enable Inverting, With 3–State Outputs	16	N	D
MC74F367	Hex Buffer/Driver, 4+2–Bit, Non–Inverting, With 3–State Outputs	16	N	D
MC74F368	Hex Buffer Driver, 4+2–Bit, Inverting, With 3–State Outputs	16	N	D
MC74F373	Octal Transparent Latch, With 3–State Outputs	20	N	DW
MC74F374	Octal D Flip–Flop, With 3–State Outputs	20	N	DW
MC74F377	Octal D Flip–Flop With Enable	20	N	DW
MC74F378	Hex Parallel D Register With Enable	16	N	D
MC74F379	Quad Parallel Register With Enable	16	N	D
MC74F381	4–Bit Arithmetic Logic Unit	20	N	DW
MC74F382	4–Bit Arithmetic Logic Unit	20	N	DW
MC74F398	Quad 2–Port Register	20	N	DW
MC74F399	Quad 2–Port Register	16	N	D
MC74F521	8–Bit Identity Comparator	20	N	DW
MC74F533	Octal Transparent Latch, With 3–State Outputs	20	N	DW
MC74F534	Octal D–Type Flip–Flop, With 3–State Outputs	20	N	DW

3

**FAST** (continued)**Numeric Listing** (continued)

Device	Function	Pins	DIP	SM
MC74F537	1-of-10 Decoder, With 3-State Outputs	20	N	DW
MC74F538	1-of-8 Decoder, With 3-State Outputs	20	N	DW
MC74F539	1-of-4 Decoder, With 3-State Outputs	20	N	DW
MC74F543	Octal Registered Transceiver Non-Inverting, With 3-State Outputs	24	N	DW
MC74F544	Octal Registered Transceiver Inverting, With 3-State Outputs	24	N	DW
MC74F568	4-Bit Bidirectional Decade Counter, With 3-State Outputs	20	N	DW
MC74F569	4-Bit Bidirectional Binary Counter, With 3-State Outputs	20	N	DW
MC74F574	Octal D Flip-Flop With 3-State Outputs/Broadside Pinout, F374	20	N	DW
MC74F579	8-Bit Bidirectional Binary Counter, With 3-State Outputs	20	N	DW
MC74F620	Octal Bus Transceiver/Inverting, With 3-State Outputs	20	N	DW
MC74F623	Octal Bus Transceiver, With 3-State Outputs	20	N	DW
MC74F640	Octal Bus Transceiver/Inverting, With 3-State Outputs	20	N	DW
MC74F646	Octal Transceiver/Register, With 3-State Outputs	24	N	DW
MC74F657A	Octal Bidirectional Transceiver With 8-Bit Parity Generator Checker, With 3-State Outputs	24	N	DW
MC74F657B	Octal Bidirectional Transceiver With 8-Bit Parity Generator Checker, With 3-State Outputs	24	N	DW
MC74F779	8-Bit Bidirectional Binary Counter, With 3-State Outputs	16	N	D
MC74F803	Clock Driver, Quad D-Type Flip-Flop, With Matched Propagation Delays	14	N	D
MC74F823	9-Bit Bus Interface, NINV, 3 State Outputs	24	N	DW
MC74F827	10-Bit Buffer/Line Driver (Non-Inverting), With 3-State Outputs	24	N	DW
MC74F828	10-Bit Buffer/Line Driver (Inverting), With 3-State Outputs	24	N	DW
MC74F1245	Octal Bidirectional Transceiver, With 3-State Inputs/Outputs	20	N	DW
MC74F1803	Clock Driver (Quad D-Type Flip-Flop) With Matched Propagation Delays	14	N	D
MC74F3893A	Quad Futurebus Backplane Transceiver, With 3-State Outputs and Open Collector	20		FN

3



## MECL Overview

Motorola's Emitter Coupled Logic is a non saturated form of digital logic which eliminates transistor storage time as a speed limiting characteristic, permitting very high speed operation.

Motorola offers four versions of MECL: MECL III, MECL 10K, MECL 10H, ECLinPS (ECL in picoseconds) and the recently introduced ECLinPS Lite family.

MECL III, the oldest MECL family still in production, has 1.0 ns gate propagation delays and greater than 500 MHz flip-flop toggle rates. MECL III is used mostly in high-speed test and communications equipment.

The MECL 10K series was the fourth generation of Motorola's ECL logic families. To make the circuits comparatively easy to use, edge speed was slowed to 2.0 ns while the important propagation delay was held to 2.0 ns. The slow edge speed permits use of wire-wrap and standard printed circuit lines, however, the circuits are specified to drive transmission lines for optimum performance.

The MECL 10H family is a higher performance, pin compatible upgrade to the MECL 10K family. MECL 10H features 100% improvement in propagation delay and clock speeds while maintaining power supply current equal to

MECL 10K. MECL 10H is voltage compensated which allows guaranteed DC and switching parameters over a  $\pm 5\%$  power supply range. MECL 10H is compatible with MECL 10K, MECL III, and ECLinPS 10E devices. The MECL 10H family includes a number of translators that allow designers to move between ECL and TTL technologies. The H600 additions to the MECL 10H family provide wide fanout translators and translating clock drivers in a 28-lead PLCC package.

The ECLinPS family represents a major advance in high-speed logic capabilities. With a gate propagation delay of only 0.33 ns and a flip-flop toggle frequency of at least 1100 MHz it literally eclipses the performance of the earlier ECL lines while maintaining signal and power-supply compatibility with MECL 10H/100H. ECLinPS functions include both 10E (10H Equivalent) and full voltage and temperature compensated 100E (100H Equivalent) versions.

In addition to the 28-lead PLCC ECLinPS family, an 8-lead SOIC ECLinPS Lite family is also available. The ECLinPS Lite family is made up of single basic logic building blocks, i.e., gates, flip-flops, line receivers and multiplexers, in both 10E and 100E varieties. The ECLinPS Lite family also includes translators to move between ECL and TTL technologies.

3

**Speed/Power Characteristics for MECL (All Typical Ratings)**

Characteristic	Symbol	MECL 10K		MECL 10H	ECLinPS & ECLinPS Lite		MECL III	Unit
		MC101xx	MC102xx	MC10H1xx	MC10E/100E	MC10EL/100EL	MC16xx	
Quiescent Supply Current/Gate	$I_G$	5.0	5.0	5.0	3.5	7.0	10	mA
Power/Gate (Quiescent)	$P_G$	26	26	26	18	36	54	mW
Propagation Delay	$t_p$	2.0	1.5	1.0	0.33	0.23	1.1	ns
Rise/Fall Time	$t_r, t_f$	2.0	1.5	1.0	0.35	0.25	0.4	ns
Speed Power Product	—	52	39	26	5.9	8.3	59	pJ
Clock Frequency (D-F/F)	$f_{max}$	125	200	250	1100	2200	550	MHz

**MECL 10K**  
**Numeric Listing**

Device	Function	Pins	DIP	SM*
MC10100	Quad 2-Input NOR Gate With Strobe	16	P,L	FN
MC10101	Quad OR/NOR Gate	16	P,L	FN
MC10102	Quad 2-Input NOR Gate	16	P,L	FN
MC10103	Quad 2-Input OR Gate	16	P,L	FN
MC10104	Quad 2-Input AND Gate	16	P,L	FN
MC10105	Triple 2-3-2 Input OR/NOR Gate	16	P,L	FN
MC10106	Triple 4-3-3 Input NOR Gate	16	P,L	FN
MC10107	Triple 2-Input Exclusive Or/Exclusive NOR Gate	16	P,L	FN
MC10109	Dual 4-5 Input OR/NOR Gate	16	P,L	FN
MC10110	Dual 3-Input 3-Output OR Gate	16	P,L	FN
MC10111	Dual 3-Input 3-Output NOR Gate	16	P,L	FN
MC10113	Quad Exclusive OR Gate	16	P,L	FN
MC10114	Triple Line Receiver	16	P,L	FN
MC10115	Quad Line Receiver	16	P,L	FN
MC10116	Triple Line Receiver	16	P,L	FN
MC10117	Dual 2-Wide 2-3-Input OR-AND/OR-AND-Invert Gate	16	P,L	FN
MC10118	Dual 2-Wide 3-Input OR-AND Gate	16	P,L	FN
MC10119	4-Wide 4-3-3-3 Input OR-AND Gate	16	P,L	FN
MC10121	4-Wide OR-AND/OR-AND-Invert Gate	16	P,L	FN
MC10123	Triple 4-3-3 Input Bus Driver (25Ω)	16	P,L	FN
MC10124	Quad TTL-to-MECL Translator	16	P,L	FN
MC10125	Quad MECL-to-TTL Translator	16	P,L	FN
MC10128	Bus Driver	16	L	
MC10129	Quad Bus Receiver	16	L	
MC10130	Dual Latch	16	P,L	FN
MC10131	Dual Type D Master-Slave Flip-Flop	16	P,L	FN
MC10132	Dual Multiplexer With Latch and Common Reset	16	P,L	
MC10133	Quad Latch	16	P,L	FN
MC10134	Dual Multiplexer With Latch	16	P,L	FN
MC10135	Dual J-K Master-Slave Flip-Flop	16	P,L	FN
MC10136	Universal Hexadecimal Counter	16	P,L	FN
MC10137	Universal Decade Counter	16	P,L	
MC10138	Bi-Quinary Counter	16	P,L	FN
MC10141	4-Bit Universal Shift Register	16	P,L	FN
MC10153	Quad Latch	16	P,L	FN
MC10154	Binary Counter	16	P,L	
MC10158	Quad 2-Input Multiplexer (Non-Inverting)	16	P,L	FN
MC10159	Quad 2-Input Multiplexer (Inverting)	16	P,L	FN
MC10160	12-Bit Parity Generator/Checker	16	P,L	FN
MC10161	Binary to 1-8 Decoder, (Low)	16	P,L	FN

\*≤ 20-Pin DIP = 20-Pin PLCC; > 20-Pin DIP = 28-Pin PLCC; See Conversion Table on Page 3.1-62

3

**MECL 10K (continued)****Numeric Listing (continued)**

Device	Function	Pins	DIP	SM*
MC10162	Binary to 1–8 Decoder, (High)	16	P,L	FN
MC10164	8–Line Multiplexer	16	P,L	FN
MC10165	8–Input Priority Encoder	16	P,L	FN
MC10166	5–Bit Magnitude Comparator	16	P,L	FN
MC10168	Quad Latch	16	P,L	FN
MC10170	9 + 2–Bit Parity Generator–Checker	16	P,L	FN
MC10171	Binary to 1–4 Decoder (Low)	16	P,L	FN
MC10172	Dual Binary to 1–4 Decoder (High)	16	P,L	FN
MC10173	Quad 2–Input Multiplexer/Latch	16	P,L	FN
MC10174	Dual 4–to–1 Multiplexer	16	P,L	FN
MC10175	Quint Latch	16	P,L	FN
MC10176	Hex D Master–Slave Flip–Flop	16	P,L	FN
MC10178	Binary Counter	16	P,L	FN
MC10181	4–Bit Arithmetic Logic Unit/Function Generator	24	P,L	
MC10186	Hex D Master–Slave Flip–Flop With Reset	16	P,L	FN
MC10188	Hex Buffer With Enable	16	P,L	FN
MC10189	Hex Inverter With Enable	16	P,L	FN
MC10190	Quad MST–to–MECL 10K Translator	16	P,L	FN
MC10192	Quad Bus Driver	16	P,L	FN
MC10193	Error Detection–Correction Circuit (Motorola Code)	16	P,L	
MC10195	Hex Inverter/Buffer	16	P,L	FN
MC10197	Hex AND Gate	16	P,L	FN
MC10198	Monostable Multivibrator	16	P,L	FN
MC10210	Dual 3–Input, 3–Output OR Gate	16	P,L	FN
MC10211	Dual 3–Input, 3–Output NOR Gate	16	P,L	FN
MC10212	High Speed Dual 3–Input 3–Output OR/NOR Gate	16	P,L	FN
MC10216	High Speed Triple Line Receiver	16	P,L	FN
MC10231	High Speed Dual D Master–Slave Flip–Flop	16	P,L	FN
MC10804	ECL/TTL Inverting Bidirectional Transceivers With Latch (4–Bit)	16	L	
MC10805	ECL/TTL Inverting Bidirectional Transceivers With Latch (5–Bit)	20	L	

\*≤ 20–Pin DIP = 20–Pin PLCC; > 20–Pin DIP = 28–Pin PLCC; See Conversion Table on Page 3.1–62

**3**

**MECL 10H**  
**Numeric Listing**

Device	Function	Pins	DIP	SM*
MC10H016	4-Bit Binary Counter	16	P,L	FN
MC10H100	Quad 2-Input NOR Gate With Strobe	16	P,L	FN
MC10H101	Quad OR/NOR Gate	16	P,L	FN
MC10H102	Quad 2-Input NOR Gate	16	P,L	FN
MC10H103	Quad 2-Input OR Gate	16	P,L	FN
MC10H104	Quad 2-Input AND Gate	16	P,L	FN
MC10H105	Triple 2-3-2 Input OR/NOR Gate	16	P,L	FN
MC10H106	Triple 4-3-3 Input NOR Gate	16	P,L	FN
MC10H107	Triple 2-Input Exclusive OR/Exclusive NOR Gate	16	P,L	FN
MC10H109	Dual 4-5 Input OR/NOR Gate	16	P,L	FN
MC10H113	Quad Exclusive OR Gate	16	P,L	FN
MC10H115	Quad Line Receiver	16	P,L	FN
MC10H116	Triple Line Receiver	16	P,L	D, FN
MC10H117	Dual 2-Wide 2-3-Input OR-AND/OR-AND-Invert Gate	16	P,L	FN
MC10H118	Dual 2-Wide 3-Input OR-AND Gate	16	P,L	FN
MC10H119	4-Wide 4-3-3-3 Input OR-AND Gate	16	P,L	FN
MC10H121	4-Wide OR-AND/OR-AND-Invert Gate	16	P,L	FN
MC10H123	Triple 4-3-3 Input Bus Driver (25Ω)	16	P,L	FN
MC10H124	Quad TTL-to-MECL Translator, With TTL Strobe Input	16	P,L	FN
MC10H125	Quad MECL-to-TTL Translator	16	P,L	FN
MC10H130	Dual Latch	16	P,L	FN
MC10H131	Dual Type-D Master-Slave Flip-Flop	16	P,L	FN
MC10H135	Dual J-K Master-Slave Flip-Flop	16	P,L	FN
MC10H136	Universal Hexadecimal Counter	16	P,L	FN
MC10H141	4-Bit Universal Shift Register	16	P,L	FN
MC10H145	16 X 4-Bit Register File (RAM)	16	P,L	FN
MC10H158	Quad 2-Input Multiplexer, Non-Inverting Output	16	P,L	FN
MC10H159	Quad 2-Input Multiplexer, Inverting Output	16	P,L	FN
MC10H160	12-Bit Parity Generator/Checker	16	P,L	FN
MC10H161	Binary to 1-8 Decoder, (Low)	16	P,L	FN
MC10H162	Binary to 1-8 Decoder, (High)	16	P,L	FN
MC10H164	8-Line Multiplexer	16	P,L	FN
MC10H165	8-Input Priority Encoder	16	P,L	FN
MC10H166	5-Bit Magnitude Comparator	16	P,L	FN
MC10H171	Dual Binary to 1-4 Decoder (Low)	16	P,L	FN
MC10H172	Dual Binary to 1-4 Decoder (High)	16	P,L	FN
MC10H173	Quad 2 Input Multiplexer With Latch	16	P,L	FN
MC10H174	Dual 4-to-1 Multiplexer	16	P,L	FN
MC10H175	Quint Latch	16	P,L	FN
MC10H176	Hex D Master-Slave Flip-Flop	16	P,L	FN

\* ≤ 20-Pin DIP = 20-Pin PLCC; > 20-Pin DIP = 28-Pin PLCC; See Conversion Table on Page 3.1-62

**3**

## MECL 10H (continued)

### Numeric Listing (continued)

Device		Function	Pins	DIP	SM*
MC10H179	—	Look Ahead Carry Block	16	P,L	FN
MC10H180	—	Dual 2–Bit Adder/Subtractor	16	P,L	FN
MC10H181	—	4–Bit Arithmetic Logic Unit/Function Generator	24	P,L	FN
MC10H186	—	Hex D Master–Slave Flip–Flop With Reset	16	P,L	FN
MC10H188	—	Hex Buffer With Enable	16	P,L	FN
MC10H189	—	Hex Inverter With Enable	16	P,L	FN
MC10H209	—	Dual 4–5–Input OR/NOR Gate	16	P,L	FN
MC10H210	—	Dual 3–Input, 3–Output OR Gate	16	P,L	FN
MC10H211	—	Dual 3–Input, 3–Output NOR Gate	16	P,L	FN
MC10H330	—	Quad Bus Driver/Receiver With 2–to–1 Output Multiplexer (25 $\Omega$ )	24	P,L	FN
MC10H332	—	Dual Bus Driver/Receiver With 4–to–1 Output Multiplexer (25 $\Omega$ )	20	P,L	FN
MC10H334	—	Quad Bus Driver/Receiver With Transmit & Receiver Latches (25 $\Omega$ )	20	P,L	FN
MC10H350	—	ECL–to–TTL Translator (Single P.S. @ + 5.0V)	16	P,L	FN
MC10H351	—	Quad TTL/NMOS–to–PECL Translator (Single P.S. @ + 5.0V)	20	P,L	FN
MC10H352	—	Quad CMOS–to–ECL Translator (Single P.S. @ + 5.0V)	20	P,L	FN
MC10H423	—	Triple 3–Input Bus Driver With Enable (25 $\Omega$ )	16	P,L	FN
MC10H424	—	Quad TTL–to–ECL Translator (ECL Strobe)	16	P,L	FN
MC10H600	MC100H600	9–Bit TTL/ECL Translator	28		FN
MC10H601	MC100H601	9–Bit ECL/TTL Translator	28		FN
MC10H602	MC100H602	9–Bit Latch TTL/ECL Translator	28		FN
MC10H603	MC100H603	9–Bit Latch ECL/TTL Translator	28		FN
MC10H604	MC100H604	Registered HEX TTL/ECL Translator	28		FN
MC10H605	MC100H605	Registered Hex ECL/TTL Translator	28		FN
MC10H606	MC100H606	Registered Hex TTL/PECL Translator	28		FN
MC10H607	MC100H607	Registered Hex PECL/TTL Translator	28		FN
MC10H640	MC100H640	68030/040 PECL/TTL Clock Driver	28		FN
MC10H641	MC100H641	Single Supply PECL/TTL 1:9 Clock Distribution Chip	28		FN
MC10H642	MC100H642	68030/040 PECL/TTL Clock Driver	28		FN
MC10H643	MC100H643	Dual Supply ECL/TTL 1:8 Clock Driver	28		FN
MC10H644	MC100H644	68030/40 PECL/TTL Clock Driver	20		FN
MC10H645	—	1:9 TTL–TTL Clock Distribution Chip	28		FN
MC10H646	MC100H646	1:8 PECL/TTL to TTL Clock Distribution Chip	28		FN
MC10H660	MC100H660	4–Bit ECL–TTL Load Reducing DRAM Driver	28		FN
MC10H680	MC100H680	4–Bit Differential ECL Bus/TTL Bus Transceiver	28		FN
MC10H681	MC100H681	Hex ECL/TTL Transceiver With Latches	28		FN

\* $\leq$  20–Pin DIP = 20–Pin PLCC;  $>$  20–Pin DIP = 28–Pin PLCC; See Conversion Table on Page 3.1–62

3

**ECLinPS**  
**Numeric Listing**

Device		Function	Pins	DIP	SM
MC10E016	MC100E016	8-Bit Synchronous Binary Up Counter	28		FN
MC10E101	MC100E101	Quad 4-Input OR/NOR Gate	28		FN
MC10E104	MC100E104	Quint 2-Input AND/NAND Gate	28		FN
MC10E107	MC100E107	Quint 2-Input XOR/XNOR Gate	28		FN
MC10E111	MC100E111	1:9 Differential Clock Driver With Low Skew, Enable, Vbb	28		FN
MC10E112	MC100E112	Quad Driver	28		FN
MC10E116	MC100E116	Quint Differential Line Receiver	28		FN
MC10E122	MC100E122	9-Bit Buffer	28		FN
MC10E131	MC100E131	4-Bit D Flip-Flop Individual Clock, Reset Differential Output	28		FN
MC10E136	MC100E136	6-Bit Universal Counter, (Lookahead Carry)	28		FN
MC10E137	MC100E137	8-Bit Ripple Counter	28		FN
MC10E141	MC100E141	8-Bit Shift Register	28		FN
MC10E142	MC100E142	9-Bit Shift Register, 700MHz, With Asynchronous Master Reset	28		FN
MC10E143	MC100E143	9-Bit Shift Register, 700MHz, With Asynchronous Master Reset	28		FN
MC10E150	MC100E150	6-Bit D Latch	28		FN
MC10E151	MC100E151	6-Bit D Register With Common Clock, Asynchronous Master Reset, Differential Outputs	28		FN
MC10E154	MC100E154	5-Bit 2:1 Mux-Latch, With Common Enable, Asynchronous Master Reset Differential Output	28		FN
MC10E155	MC100E155	6-Bit 2:1 Mux-Latch, With Common Enable, Asynchronous Master Reset Single Ended	28		FN
MC10E156	MC100E156	3-Bit 4:1 Mux-Latch, With Common Enable, Asynchronous Master Reset, Differential Output	28		FN
MC10E157	MC100E157	Quad 2:1 Mux, Individual-Select	28		FN
MC10E158	MC100E158	5-Bit 2:1 Multiplexer, With Differential Output	28		FN
MC10E160	MC100E160	12-Bit Parity Generator/Checker, Register-Shifttable, Differential Output	28		FN
MC10E163	MC100E163	2-Bit 8:1 Multiplexer	28		FN
MC10E164	MC100E164	16:1 Multiplexer	28		FN
MC10E166	MC100E166	9-Bit Magnitude Comparator	28		FN
MC10E167	MC100E167	6-Bit 2:1 Mux-Register With Common Clock, Asynchronous Master Reset Single Ended	28		FN
MC10E171	MC100E171	3-Bit 4:1 Multiplexer, With Split Select Differential Output	28		FN
MC10E175	MC100E175	9-Bit Latch, With Parity	28		FN
MC10E193	MC100E193	Error Detection and Correction Circuit	28		FN
MC10E195	MC100E195	Programmable Delay Chip (Digitally Selectable 20ps Res)	28		FN
MC10E196	MC100E196	Programmable Delay Chip (Dig 80ps Anal. 1.6 Ps/mv)	28		FN
MC10E197	—	Data Separator	28		FN
MC10E211	MC100E211	1:6 Differential Clock Distribution Chip	28		FN
MC10E212	MC100E212	3-Bit Scannable Registered Address Driver, ECL	28		FN
MC10E241	MC100E241	8-Bit Scannable Register	28		FN
MC10E256	MC100E256	3-Bit 4:1 Mux-Latch (Integrated E156 & E171)	28		FN
MC10E336	MC100E336	3-Bit Registered Bus Transceiver, 25Ω Cutoff Outputs	28		FN

3

**ECLinPS** (continued)  
**Numeric Listing** (continued)

Device		Function	Pins	DIP	SM
MC10E337	MC100E337	3–Bit Scannable Registered Bus Transceiver	28		FN
MC10E404	MC100E404	Quad Differential AND/NAND Gate	28		FN
MC10E416	MC100E416	Quint Differential Line Receiver	28		FN
MC10E431	MC100E431	3–Bit Differential Flip–Flop	28		FN
MC10E445	MC100E445	4–Bit Serial/Parallel Converter	28		FN
MC10E446	MC100E446	4–Bit Parallel/Serail Converter	28		FN
MC10E451	MC100E451	6–Bit D Register, With Differential Inputs, (Data & Clock) , Vbb, Common Reset	28		FN
MC10E452	MC100E452	5–Bit Differential Register	28		FN
MC10E457	MC100E457	Triple Differential 2:1 Multiplexer	28		FN
MC10E1651	—	Dual Analog Comparator With Latch	16	L	FN
MC10E1652	—	Dual Analog Comparator With Latch (High Performance Version of MC1651)	16	L	FN

**3**

**ECLinPS Lite**  
**Numeric Listing**

Device		Function	Pins	DIP	SM*
MC10EL01	MC100EL01	4–Input OR/NOR Gate	8		D
MC10EL04	MC100EL04	2–Input AND/NAND Gate	8		D
MC10EL05	MC100EL05	2–Input Differential AND/NAND Gate	8		D
MC10EL07	MC100EL07	2–Input XOR/NOR Gate	8		D
MC10EL11	MC100EL11	1:2 Differential Clock Driver	8		D
MC10EL12	MC100EL12	Driver	8		D
MC10EL16	MC100EL16	Differential Receiver	8		D
MC10EL31	MC100EL31	D Flip–Flop With Set & Reset	8		D
MC10EL32	MC100EL32	P 2 Divider	8		D
MC10EL33	MC100EL33	P 4 Divider	8		D
MC10EL35	MC100EL35	J–K Flip–Flop	8		D
MC10EL51	MC100EL51	Differential Clock D Flip–Flop	8		D
MC10EL52	MC100EL52	Differential Data & Clock D Flip–Flop	8		D
MC10EL58	MC100EL58	2:1 Multiplexer	8		D
MC10EL89	—	Coaxial Cable Driver	8		D
MC10ELT25	MC100ELT25	Differential ECL–to–TTL Translator	8		D

# CMOS Overview

Motorola offers three complete CMOS families, each enhanced for different design applications. Metal Gate CMOS, for low power and wide ranging voltage applications; High-Speed CMOS for compatibility with LSTTL; and FACT (Advanced CMOS) combining the best of both families with high speed, low power and high output drive characteristics.

## Metal Gate

Motorola's Standard 14000 Series Metal Gate CMOS logic family consists of a full line of products which are pinout compatible with many LSTTL and High-Speed CMOS series devices. These Metal Gate CMOS devices meet or exceed the industry-standardized family specifications. Some additional features are:

- Very Low Power Dissipation
- Available Packages: Dual-in-Line Ceramic, Dual-in-Line Plastic and SOIC
- Electrical Parameters Specified  $-55^{\circ}\text{C}$  to  $+125^{\circ}\text{C}$  on all packages
- 3-18 Volt Operational Limits
- Parameters Specified at 5.0V, 10V and 15V Supply
- Capable of Driving Two Low-Power TTL Loads or One Low-Power Schottky TTL Load Over the Rated Temperature Range
- Direct Interface to High-Speed CMOS and Many LSTTL Devices
- Maximum Input Current of  $\pm 1.0\mu\text{A}$  at 15V Power Supply Over the Temperature Range

- Noise Margins:
  - B Series (Buffered)
    - 1.0V Min @ 5.0V Supply
    - 2.0V Min @ 10V Supply
    - 2.5V Min @ 15V Supply
  - UB Series (Unbuffered)
    - 0.5V Min @ 5.0V Supply
    - 1.0V Min @ 10V Supply
    - 1.0V Min @ 15V Supply
- UB Devices Have Single Inverting Stage Between Input and Output
  - Can Be Used in a Linear Mode to Form Oscillators, Monostables or Amplifiers
  - Decreased Gain Results in Increased Stability and a Cleaner Output Waveform
  - Increases Speed Since Only a Single Stage Is Involved

3

## High-Speed

Motorola's High-Speed CMOS logic family consists of a full line of products that are pinout compatible with many LSTTL and MC14000B Standard CMOS series devices. Use of silicon-gate processing technology allows the High-Speed CMOS family to combine the switching speeds and operating frequencies of LSTTL with the lower power consumption and high noise immunity advantages of CMOS.

- Wide Operating Voltage Range
  - HC/HCU: 2.0-6.0V Recommended
  - HCT: 5.0V  $\pm 10\%$  Recommended
- High Noise Immunity
- High Fanout
  - Standard Outputs Drive 10 LSTTL Loads (4mA)
  - Bus Outputs Drive 15 LSTTL Loads (6mA)
- Wide Operating Temperature Range:  $-55^{\circ}\text{C}$  to  $+125^{\circ}\text{C}$
- Low Input Current
- Low Power Dissipation
- Improved ESD and Latch-Up Performance
- Direct Pin Compatibility:
  - HCXXX or HCTXXX With LSTTL
  - HC4XXX With CMOS
- Input Logic Compatible:
  - HCXXX or HC4XXX With CMOS
  - HCTXXX With LSTTL
- Available Packages: Dual-in-Line Ceramic, Dual-in-Line Plastic and SOIC
- Proven Reliability and Process:
  - Reliability Report Available From Your Local Motorola Sales Office



## FACT

Motorola FACT is the latest advanced family of CMOS logic devices which offer system designers a solution to the problem of high speed and low power in a standard product. Until now, designers had to choose between either high speed with large power consumption, or low power with low speed.

Motorola FACT is fabricated using a sub-two micron, silicon gate process. This process has been proven in the past few years in high performance gate arrays and is the basis of the product family for future logic systems.

FACT is faster than any previous CMOS technology and approaches the speed of advanced bipolar devices. This superior speed allow direct replacement of slower speed CMOS or bipolar products with the inherent capabilities of advanced CMOS.

Low power consumption is a major advantage of CMOS. During standby operating mode, power consumption is near zero.

- High Output Drive: Sink or Source 24mA
- Providing Wide Logic Fanout and Will Drive a 50Ω Transmission Line
- Noise Immunity: Consistent, Predictable, Wide Margin Input Switching Level
- Standardized Packages/Pinouts: Available in Either Dual-in-Line or SOIC Packages
- Function Pinouts Adhere to Industry Standards for Interchangeability and Circuit Layout
- Motorola FACT Is Directly Interchangeable and Has Identical Performance Specifications With FACT From National Semiconductor Corporation

# 3

## CMOS Family Comparisons

General Characteristics (All Maximum Ratings)

Characteristics	Symbol	LS	ALS	HCMOS	FACT	Unit
Operating Voltage Range	V <sub>CC</sub> /EE/DD	5 ± 5%	5 ± 10%	2.0 to 6.0	2.0 to 6.0	V
Operating Temperature	t <sub>A</sub> 74 Series	0 to +70	0 to +70	-55 to +125	-40 to +85	°C
Input Voltage (limits)	V <sub>IH</sub> (min)	2.0	2.0	3.15	3.15	V
	V <sub>IL</sub> (max)	0.8	0.8	0.9	1.35	V
Output Voltage (limits)	V <sub>OH</sub> (min)	2.7	2.7	V <sub>CC</sub> - 0.1	V <sub>CC</sub> - 0.1	V
	V <sub>OL</sub> (max)	0.5	0.5	0.1	0.1	V
Input Current	I <sub>IH</sub>	20	20	+1.0	+1.0	μA
	I <sub>IL</sub>	-400	-200	-1.0	-1.0	μA
Output Current @ V <sub>O</sub> (limit)	I <sub>OH</sub>	-0.4	-0.4	-4.0 @ V <sub>CC</sub> - 0.8	-24 @ V <sub>CC</sub> - 0.8	mA
	I <sub>OL</sub>	8.0	8.0	4.0 @ 0.4 V	24 @ 0.4 V	mA
DC Noise Margin LOW/HIGH	DCM	0.3/0.7	0.4/0.7	0.8/1.25	1.25/1.25	V
DC Fanout (LSTTL Unit Loads)		20	20	10	60	Unit Loads

Speed/Power Characteristics (All Typical Ratings)

Characteristics	Symbol	LS	ALS	HCMOS	FACT	Unit
Quiescent Supply Current/Gate	I <sub>G</sub>	0.4	0.2	0.0005	0.0005	mA
Power/Gate (Quiescent)	P <sub>G</sub>	2.0	1.2	0.0025	0.0025	mW
Propagation Delay	t <sub>p</sub>	7.0	5.0	8.0	4.8	ns
Speed Power Product	—	14	6.0	0.02	0.01	pJ
Clock Frequency D/FF	f <sub>max</sub>	33	50	50	160	MHz

**Metal Gate 1400 Series**  
**Numeric Listing**

Device	Function	Pins	DIP	SM
MC1400UB	Dual 3-Input NOR Gate + Inverter (Unbuffered)	14	P,L	D
MC14001B	Quad 2-Input NOR Gate	14	P,L	D
MC14001UB	Quad 2-Input NOR Gate (Unbuffered)	14	P,L	D
MC14002B	Dual 4-Input NOR Gate	14	P,L	D
MC14002UB	Dual 4-Input NOR Gate (Unbuffered)	14	P,L	D
MC14006B	18-Bit Static Shift Register	14	P,L	D
MC14007UB	Dual Complementary Pair Plus Inverter (Unbuffered)	14	P,L	D
MC14008B	4-Bit Full Adder	16	P,L	D
MC14011B	Quad 2-Input NAND Gate	14	P,L	D
MC14011UB	Quad 2-Input NAND Gate (Unbuffered)	14	P,L	D
MC14012B	Dual 4-Input NAND Gate	14	P,L	D
MC14012UB	Dual 4-Input NAND Gate (Unbuffered)	14	P,L	D
MC14013B	Dual D Flip-Flop	14	P,L	D
MC14014B	8-Bit Static Shift Register	16	P,L	D
MC14015B	Dual 5-Bit Shift Register	16	P,L	D
MC14016B	Quad Analog Switch/Multiplexer	14	P,L	D
MC14017B	Decade Counter	16	P,L	D
MC14018B	Presetable Divide-by-N Counter	16	P,L	D
MC14020B	14-Bit Binary Counter	16	P,L	D
MC14021B	8-Bit Static Shift Register	16	P,L	D
MC14022B	Octal Counter	16	P,L	D
MC14023B	Triple 3-Input NAND Gate	14	P,L	D
MC14023UB	Triple 3-Input NAND Gate (Unbuffered)	14	P,L	D
MC14024B	7-stage Ripple Counter	14	P,L	D
MC14025B	Triple 3-Input NOR Gate	14	P,L	D
MC14025UB	Triple 3-Input NOR Gate (Unbuffered)	14	P,L	D
MC14027B	Dual J-K Flip-Flop	16	P,L	D
MC14028B	BCD-to-Decimal Decoder	16	P,L	D
MC14029B	Presetable Binary/BCD Up/Down Counter	16	P,L	D
MC14035B	4-Bit Shift Register	16	P,L	D
MC14038B	Triple Serial Adder (Negative Logic)	16	P,L	D
MC14040B	12-Bit Binary Counter	16	P,L	D
MC14042B	Quad Transparent Latch	16	P,L	D
MC14043B	Quad NOR R-S Latch	16	P,L	D
MC14044B	Quad NAND R-S Latch	16	P,L	D
MC14046B	Phase-Locked Loop	16	P,L	DW
MC14049B	Hex Inverter/Buffer	16	P,L	D
MC14049UB	Hex Inverter/Buffer (Unbuffered)	16	P,L	D
MC14050B	Hex Buffer/Non-Inverting	16	P,L	D
MC14051B	8-Channel Analog Multiplexer/Demultiplexer	16	P,L	D

**3**

## Metal Gate 14000 Series (continued)

### Numeric Listing (continued)

Device	Function	Pins	DIP	SM
MC14052B	Dual 4-Channel Analog Multiplexer/Demultiplexer	16	P,L	D
MC14053B	Triple 2-Channel Analog Multiplexer/Demultiplexer	16	P,L	D
MC14060B	14-Bit Binary Counter and Oscillator	16	P,L	D
MC14066B	Quad Analog Switch/Multiplexer	14	P,L	D
MC14067B	16-Channel Analog Multiplexer/Demultiplexer	24	P,L	DW
MC14068B	8-Input NAND Gate	14	P,L	D
MC14069UB	Hex Inverter (Unbuffered)	14	P,L	D
MC14070B	Quad Exclusive OR Gate	14	P,L	D
MC14071B	Quad 2-Input OR Gate	14	P,L	D
MC14072B	Dual 4-Input OR Gate	14	P,L	D
MC14073B	Triple 3-Input AND Gate	14	P,L	D
MC14075B	Triple 3-Input OR Gate	14	P,L	D
MC14076B	Quad D-Type Register With 3-State Outputs	16	P,L	D
MC14077B	Quad Exclusive NOR Gate	14	P,L	D
MC14078B	8-Input NOR Gate	14	P,L	D
MC14081B	Quad 2-Input AND Gate	14	P,L	D
MC14082B	Dual 4-Input AND Gate	14	P,L	D
MC14093B	Quad 2-Input NAND Schmitt Trigger	14	P,L	D
MC14094B	8-Stage Shift/Store Register With 3-State Outputs	16	P,L	D
MC14099B	8-Bit Addressable Latch	16	P,L	DW
MC14106B	Hex Schmitt Trigger	14	P,L	D
MC14161B	4-Bit Binary Counter, Synchronous Presettable	16	P,L	D
MC14163B	4-Bit Binary Counter, Synchronous Presettable	16	P,L	D
MC14174B	Hex D Flip-Flop	16	P,L	D
MC14175B	Quad D Flip-Flop	16	P,L	D
MC14194B	4-Bit Universal Shift Register	16	P,L	D
MC14415	Quad Precision Timer/Driver (Buffered)	16	P,L	DW
MC14490	Hex Contact Bounce Eliminator (Buffered)	16	P,L	DW
MC14500B	Industrial Control Unit	16	P,L	DW
MC14501UB	Dual 4-Input NAND, 2-Input NOR/OR, 8-Input AND/NAND Gate (Unbuffered)	16	P,L	D
MC14502B	Strobed Hex Inverter/Buffer	16	P,L	DW
MC14503B	Hex With 3-State Outputs Buffer (Non-Inverting)	16	P,L	D
MC14504B	Hex TTL OR CMOS to CMOS Hex Level Shifter	16	P,L	D
MC14506UB	Dual Expandable AND OR Invert Gate (Unbuffered)	16	P,L	D
MC14508B	Dual 4-Bit Latch	24	P,L	DW
MC14510B	Presettable BCD Up/Down Counter	16	P,L	D
MC14511B	BCD-to-7-segment Latch/Decoder/Driver	16	P,L	D,DW
MC14512B	8-Channel Data Selector	16	P,L	D
MC14513B	BCD-to-7-Segment Latch/Decoder/Driver With Ripple Blanking	18	P,L	
MC14514B	4-Bit Transparent Latch/4-to-16 Line Decoder(High)	24	P,L	DW

3

## Metal Gate 14000 Series (continued)

### Numeric Listing (continued)

Device	Function	Pins	DIP	SM
MC14515B	4–Bit Transparent Latch/4–to–16 Line Decoder(Low)	24	P,L	DW
MC14516B	Presettable Binary Up/Down Counter	16	P,L	D
MC14517B	Dual 64–Bit Static Shift Register	16	P,L	DW
MC14518B	Dual BCD Up Counter	16	P,L	DW
MC14519B	4–Bit AND/OR Selector	16	P,L	D
MC14520B	Dual Binary Up Counter	16	P,L	DW
MC14521B	24–Stage Frequency Divider	16	P,L	D
MC14522B	Presettable 4–Bit BCD Down Counter	16	P,L	DW
MC14526B	Presettable 4–Bit Binary Down Counter	16	P,L	DW
MC14527B	BCD Rate Multiplier	16	P,L	DW
MC14528B	Dual Monostable Multivibrator	16	P,L	D
MC14529B	Dual 4–Channel Analog Data Selector	16	P,L	D
MC14530B	Dual 5–Input Majority Logic Gate	16	P,L	D
MC14531B	12–Bit Parity Tree	16	P,L	D
MC14532B	8–Bit Priority Encoder	16	P,L	D
MC14534B	5 Cascaded BCD Counters	24	P,L	DW
MC14536B	Programmable Timer	16	P,L	DW
MC14538B	Dual Precision Monostable Multivibrator	16	P,L	D, DW
MC14539B	Dual 4–Channel Data Selector/Multiplexer	16	P,L	D
MC14541B	Programmable Oscillator Timer	14	P,L	D
MC14543B	BCD–to–7–Segment Latch/Decoder/Driver for Liquid Crystals	16	P,L	D
MC14544B	BCD–to–7–Segment Latch/Decoder/Driver With Ripple Blanking	18	P,L	
MC14547B	High Current BCD–to–7–Segment Decoder/Driver	16	P,L	DW
MC14549B	Successive Approximation Register	16	P,L	DW
MC14551B	Quad 2–Channel Analog Multiplexer/Demultiplexer	16	P,L	D
MC14553B	3–Digit BCD Counter	16	P,L	DW
MC14555B	Dual Binary to 1–of–4 Decoder (Active High Outputs)	16	P,L	D
MC14556B	Dual Binary to 1–of–4 Decoder (Active Low Outputs)	16	P,L	D
MC14557B	1–to–64–Bit Variable Length Shift Register	16	P,L	DW
MC14558B	BCD–to–7–Segment Decoder	16	P,L	D
MC14559B	Successive Approximation Register	16	P,L	DW
MC14560B	NBCD Adder	16	P,L	D
MC14561B	9's Complementer	14	P,L	D
MC14562B	128–Bit Static Shift Register	14	P,L	
MC14566B	Industrial Time Base Generator	16	P,L	D
MC14568B	Phase Comparator and Programmable Counter	16	P,L	D
MC14569B	Programmable Dual Binary/BCD Counter	16	P,L	DW
MC14572UB	Hex NAND/NOR/Invert Gate (Unbuffered)	16	P,L	D
MC14583B	Dual Schmitt Trigger	16	P,L	D
MC14584B	Hex Schmitt Trigger	14	P,L	D

3

## Metal Gate 14000 Series (continued)

### Numeric Listing (continued)

Device	Function	Pins	DIP	SM
MC14585B	4–Bit Magnitude Comparator	16	P,L	D
MC14598B	8–Bit Bus Compatible Addressable Latch	18	P,L	
MC14599B	8–Bit Addressable Latch	18	P,L	

## High–Speed Numeric Listing

Device	Function	Pins	DIP	SM	
MC54HC00A	MC74HC00A	Quad 2–Input NAND Gate	14	N,J	D
MC54HC02A	MC74HC02A	Quad 2–Input NOR Gate	14	N,J	D
MC54HC03A	MC74HC03A	Quad 2–Input NAND Gate With Open–Drain Outputs	14	N,J	D
MC54HC04A	MC74HC04A	Hex Inverter	14	N,J	D
MC54HCU04	MC74HCU04	Hex Unbuffered Inverter	14	N,J	D
MC54HC08A	MC74HC08A	Quad 2–Input AND Gate	14	N,J	D
MC54HC10	MC74HC10	Triple 3–Input NAND Gate	14	N,J	D
MC54HC11	MC74HC11	Triple 3–Input AND Gate	14	N,J	D
MC54HC14A	MC74HC14A	Hex Schmitt Trigger Inverter	14	N,J	D
MC54HC20	MC74HC20	Dual 4–Input NAND Gate	14	N,J	D
MC54HC27	MC74HC27	Triple 3–Input NOR Gate	14	N,J	D
MC54HC30	MC74HC30	8–Input NAND Gate	14	N,J	D
MC54HC32A	MC74HC32A	Quad 2–Input OR Gate	14	N,J	D
MC54HC42	MC74HC42	1–of–10 Decoder	16	N,J	D
MC54HC51	MC74HC51	2–Wide, 2–Input/2–Wide, 3–Input AND–NOR Gate	14	N,J	D
MC54HC58	MC74HC58	2–Wide, 2–Input/2–Wide, 3–Input AND–OR Gate	14	N,J	D
MC54HC73	MC74HC73	Dual J–K Flip–Flop With Reset	14	N,J	D
MC54HC74A	MC74HC74A	Dual D Flip–Flop With Set and Reset	14	N,J	D
MC54HC75	MC74HC75	Dual 2–Bit Transparent Latch	16	N,J	D
MC54HC85	MC74HC85	4–Bit Magnitude Comparator	16	N,J	
MC54HC86	MC74HC86	Quad 2–Input Exclusive OR Gate	14	N,J	D
MC54HC107	MC74HC107	Dual J–K Flip–Flop With Reset	14	N,J	D
MC54HC109	MC74HC109	Dual J–K(bar) Flip–Flop With Set and Reset	16	N,J	D
MC54HC112	MC74HC112	Dual J–K Flip–Flop With Set and Reset	16	N,J	D
MC54HC125A	MC74HC125A	Quad With 3–State Outputs Non–Inverting Buffer	14	N,J	D
MC54HC126A	MC74HC126A	Quad With 3–State Outputs Non–Inverting Buffer	14	N,J	D
MC54HC132A	MC74HC132A	Quad 2–Input NAND Gate With Schmitt Trigger Inputs	14	N,J	D
MC54HC133	MC74HC133	13–Input NAND Gate	16	N,J	D
MC54HC137	MC74HC137	1–of–8 Decoder/Demultiplexer With Address Latch	16	N,J	D
MC54HC138A	MC74HC138A	1–of–8 Decoder/Demultiplexer	16	N,J	D
MC54HC139A	MC74HC139A	Dual 1–of–4 Decoder/Demultiplexer	16	N,J	D
MC54HC147	MC74HC147	Decimal–to–BCD Encoder	16	N,J	D
MC54HC151	MC74HC151	8–Input Data Selector/Multiplexer	16	N,J	D
MC54HC153	MC74HC153	Dual 4–Input Data Selector/Multiplexer	16	N,J	D

3

## High-Speed (continued)

### Numeric Listing (continued)

Device		Function	Pins	DIP	SM
MC54HC154	MC74HC154	1-of-16 Decoder/Demultiplexer	24	N,J	DW
MC54HC157A	MC74HC157A	Quad 2-Input Data Selector/Multiplexer	16	N,J	D
MC54HC160	MC74HC160	Presetable Counter	16	N,J	D
MC54HC161A	MC74HC161A	Presetable Counter	16	N,J	D
MC54HC162	MC74HC162	Presetable Counter	16	N,J	D
MC54HC163A	MC74HC163A	Presetable Counter	16	N,J	D
MC54HC164	MC74HC164	8-Bit Serial-Input/Parallel-Output Shift Register	14	N,J	
MC54HC165	MC74HC165	8-Bit Serial or Parallel-Input/Serial-Output Shift Register	16	N,J	D
MC54HC173	MC74HC173	Quad With 3-State Outputs D Flip-Flop With Common Clock & Reset	16	N,J	D
MC54HC174A	MC74HC174A	Hex D Flip-Flop With Common Clock & Reset	16	N,J	D
MC54HC175	MC74HC175	Quad D Flip-Flop With Common Clock & Reset	16	N,J	D
MC54HC194	MC74HC194	4-Bit Bidirectional Universal Shift Register	16	N,J	
MC54HC195	MC74HC195	4-Bit Universal Shift Register	16	N,J	
MC54HC237	MC74HC237	1-of-8 Decoder/Demultiplexer With Address Latch	16	N,J	D
MC54HC240A	MC74HC240A	Octal With 3-State Outputs Inverting Buffer/Line Driver/line Receiver	20	N,J	DW
MC54HC241A	MC74HC241A	Octal With 3-State Outputs Non-Inverting Buffer/Line Driver/Line Receiver	20	N,J	DW
MC54HC242	MC74HC242	Quad With 3-State Outputs Inverting Bus Transceiver	14	N,J	
MC54HC244A	MC74HC244A	Octal With 3-State Outputs Non-Inverting Buffer/Line Driver/Line Receiver	20	N,J	DW
MC54HC245A	MC74HC245A	Octal With 3-State Outputs Non-Inverting Bus Transceiver	20	N,J	DW
MC54HC251	MC74HC251	8-Input Data Selector/Multiplexer With 3-State Outputs	16	N,J	D
MC54HC253	MC74HC253	Dual 4-Input Data Selector/Multiplexer With 3-State Outputs	16	N,J	D
MC54HC257	MC74HC257	Quad 2-Input Data Selector/Multiplexer With 3-State Outputs	16	N,J	D
MC54HC259	MC74HC259	8-Bit Addressable Latch/1-of-8 Decoder	16	N,J	D
MC54HC273A	MC74HC273A	Octal D Flip-Flop With Common Clock & Reset	20	N,J	DW
MC54HC280	MC74HC280	9-Bit Odd/Even Parity Generator/Checker	14	N,J	D
MC54HC299	MC74HC299	8-Bit Bidirectional Universal Shift Register With parallel I/O	20	N,J	DW
MC54HC365	MC74HC365	Hex With 3-State Outputs Non-Inverting Buffer With Separate 2-Bit/4-Bit Sections	16	N,J	
MC54HC366	MC74HC366	Hex With 3-State Outputs Inverting Buffer With Common Enables	16	N,J	
MC54HC367	MC74HC367	Hex With 3-State Outputs Non-Inverting Buffer With Separate 2-Bit and 4-Bit Sections	16	N,J	
MC54HC368	MC74HC368	Hex With 3-State Outputs Inverting Buffer With Separate 2-Bit and 4-Bit Sections	16	N,J	
MC54HC373A	MC74HC373A	Octal With 3-State Outputs Non-Inverting Transparent Latch	20	N,J	DW
MC54HC374A	MC74HC374A	Octal With 3-State Outputs Non-Inverting D Flip-Flop	20	N,J	DW
MC54HC390	MC74HC390	Dual 4-Stage Binary Ripple Counter W +2, +5 Sections	16	N,J	D
MC54HC393	MC74HC393	Dual 4-Stage Binary Ripple Counter	14	N,J	D
MC54HC534A	MC74HC534A	Octal With 3-State Outputs Inverting D Flip-Flop	20	N,J	DW
MC54HC540	MC74HC540	Octal With 3-State Outputs Inverting Buffer/Line Driver/Line Receiver	20	N,J	DW

3

**High-Speed** (continued)  
**Numeric Listing** (continued)

Device		Function	Pins	DIP	SM
MC54HC541	MC74HC541	Octal With 3-State Outputs Non-Inverting Buffer/Line Driver/Line Receiver	20	N,J	DW
MC54HC563	MC74HC563	Octal With 3-State Outputs Inverting Transparent Latch	20	N,J	DW
MC54HC564	MC74HC564	Octal With 3-State Outputs Inverting D Flip-Flop	20	N,J	DW
MC54HC573A	MC74HC573A	Octal With 3-State Outputs Non-Inverting Transparent Latch	20	N,J	DW
MC54HC574A	MC74HC574A	Octal With 3-State Outputs Non-Inverting D Flip-Flop	20	N,J	DW
MC54HC589	MC74HC589	8-Bit Serial or Parallel-Input/Serial-Output Shift Register With 3-State Outputs	16	N,J	D
MC54HC595A	MC74HC595A	8-Bit Serial-Input/Serial or Parallel-Output Shift Register With Latched 3-State Outputs	16	N,J	D
MC54HC597	MC74HC597	8-Bit Serial or Parallel-Input/Serial-Output Shift Register With Input Latch	16	N,J	D
MC54HC640A	MC74HC640A	Octal With 3-State Outputs Inverting Bus Transceiver	20	N,J	DW
MC54HC646	MC74HC646	Octal With 3-State Outputs Non-Inverting Bus Transceiver & D Flip-Flop	24	N,J	DW
MC54HC688	MC74HC688	8-Bit Equality Comparator	20	N,J	DW
MC54HC4002	MC74HC4002	Dual 4-Input NOR Gate	14	N,J	D
MC54HC4016	MC74HC4016	Quad Analog Switch/Multiplexer/Demultiplexer	14	N,J	D
MC54HC4017	MC74HC4017	Decade Counter	16	N,J	D
MC54HC4020	MC74HC4020	14-Stage Binary Ripple Counter	16	N,J	
MC54HC4024	MC74HC4024	7-Stage Binary Ripple Counter	14	N,J	D
MC54HC4040	MC74HC4040	12-Stage Binary Ripple Counter	16	N,J	
MC54HC4046A	MC74HC4046A	Phase-Locked-Loop With VCO	16	N,J	D
MC54HC4049	MC74HC4049	Hex Inverting Buffer/Logic-Level Down Converter	16	N,J	D
MC54HC4050	MC74HC4050	Hex Non-Inverting Buffer/Logic-Level Down Converter	16	N,J	D
MC54HC4051	MC74HC4051	8-Channel Analog Multiplexer/Demultiplexer	16	N,J	DW
MC54HC4052	MC74HC4052	Dual 4-Channel Analog Multiplexer/Demultiplexer	16	N,J	DW
MC54HC4053	MC74HC4053	Triple 2-Channel Analog Multiplexer/Demultiplexer	16	N,J	DW
MC54HC4060	MC74HC4060	14-Stage Binary Ripple Counter With Oscillator	16	N,J	
MC54HC4066	MC74HC4066	Quad Analog Switch/Multiplexer/Demultiplexer	14	N,J	D
MC54HC4075	MC74HC4075	Triplé 3-Input OR Gate	14	N,J	D
MC54HC4078	MC74HC4078	8-Input NOR/OR Gate	14	N,J	D
MC54HC4316	MC74HC4316	Quad Analog Switch/Multiplexer/Demultiplexer With Separate Analog/Digital Power Supplies	16	N,J	D
MC54HC4351	MC74HC4351	8-Channel Analog Multiplexer/Demultiplexer With Address Latch	20	N,J	DW
MC54HC4353	MC74HC4353	Triple 2-Channel Analog Multiplexer/Demultiplexer With Address Latch	20	N,J	DW
MC54HC4511	MC74HC4511	BCD-to-7 Segment Latch/Decoder/Display Driver	16	N,J	D
MC54HC4514	MC74HC4514	1-of-16 Decoder/Demultiplexer With Address Latch	24	N,J	DW
MC54HC4538A	MC74HC4538A	Dual Precision Monostable Multivibrator Retriggerable, Resettable)	16	N,J	D
MC54HC7266	MC74HC7266	Quad 2-Input Exclusive NOR Gate	14	N,J	D

3

## High-Speed — TTL Compatible Devices

### Numeric Listing

Device		Function	Pins	DIP	SM
MC54HCT00A	MC74HCT00A	Quad 2-Input NAND Gate	14	N,J	D
MC54HCT04A	MC74HCT04A	Hex Inverter	14	N,J	D
MC54HCT08A	MC74HCT08A	Quad 2-Input AND Gate	14	N,J	D
MC54HCT14A	MC74HCT14A	Hex Schmitt Trigger Inverter	14	N,J	D
MC54HCT32A	MC74HCT32A	Quad 2-Input OR Gate	14	N,J	D
MC54HCT74A	MC74HCT74A	Dual D Flip-Flop With Set and Reset	14	N,J	D
MC54HCT138A	MC74HCT138A	1-of-8 Decoder/Demultiplexer	16	N,J	D
MC54HCT157A	MC74HCT157A	Quad 2-Input Data Selector/Multiplexer	16	N,J	D
MC54HCT174A	MC74HCT174A	Hex D Flip-Flop With Common Clock & Reset	16	N,J	D
MC54HCT240A	MC74HCT240A	Octal With 3-State Outputs Inverting Buffer/Line Driver/line Receiver	20	N,J	DW
MC54HCT241A	MC74HCT241A	Octal With 3-State Outputs Non-Inverting Buffer/Line Driver/Line Receiver	20	N,J	DW
MC54HCT244A	MC74HCT244A	Octal With 3-State Outputs Non-Inverting Buffer/Line Driver/Line Receiver	20	N,J	DW
MC54HCT245A	MC74HCT245A	Octal With 3-State Outputs Non-Inverting Bus Transceiver	20	N,J	DW
MC54HCT273A	MC74HCT273A	Octal D Flip-Flop With Common Clock & Reset	20	N,J	DW
MC54HCT373A	MC74HCT373A	Octal With 3-State Outputs Non-Inverting Transparent Latch	20	N,J	DW
MC54HCT374A	MC74HCT374A	Octal With 3-State Outputs Non-Inverting D Flip-Flop	20	N,J	DW
MC54HCT541	MC74HCT541	Octal With 3-State Outputs Non-Inverting Buffer/Line Driver/Line Receiver	20	N,J	DW
MC54HCT573A	MC74HCT573A	Octal With 3-State Outputs Non-Inverting Transparent Latch	20	N,J	DW
MC54HCT574A	MC74HCT574A	Octal With 3-State Outputs Non-Inverting D Flip-Flop	20	N,J	DW
MC54HCT640A	MC74HCT640A	Octal With 3-State Outputs Inverting Bus Transceiver	20	N,J	DW

3

## FACT

### Numeric Listing

Device	Function	Pins	DIP	SM
MC74AC00	Quad 2-Input NAND Gate	14	N	D
MC74AC02	Quad 2-Input NOR Gate	14	N	D
MC74AC04	Hex Inverter	14	N	D
MC74AC05	Hex Inverter With Open Drain Outputs	14	N	D
MC74AC08	Quad 2-Input AND Gate	14	N	D
MC74AC10	Triple 3-Input NAND Gate	14	N	D
MC74AC11	Triple 3-Input AND Gate	14	N	D
MC74AC14	Hex Inverter Schmitt Trigger	14	N	D
MC74AC20	Dual 4-Input NAND Gate	14	N	D
MC74AC32	Quad 2-Input OR Gate	14	N	D
MC74AC74	Dual D Flip-Flop	14	N	D
MC74AC86	Quad 2-Input Exclusive OR Gate	14	N	D
MC74AC109	Dual J-K Positive Edge-Triggered Flip-Flop With Set & Clear	16	N	D
MC74AC112	Dual J-K Flip-Flop Negative Edge-Triggered	16	N	D
MC74AC113	Dual J-K Flip-Flop Negative Edge-Triggered	14	N	D



**FACT** (continued)  
**Numeric Listing** (continued)

Device	Function	Pins	DIP	SM
MC74AC125	Quad Buffer With 3-State Outputs	14	N	D
MC74AC126	Quad Buffer With 3-State Outputs	14	N	D
MC74AC132	Quad 2-Input NAND Schmitt Trigger	14	N	D
MC74AC138	1-of-8 Decoder/Demultiplexer	16	N	D
MC74AC139	Dual 1-of-4 Decoder/Demultiplexer	16	N	D
MC74AC151	1-of-8 Decoder/Multiplexer	16	N	D
MC74AC153	Dual 4-Input Multiplexer	16	N	D
MC74AC157	Quad 2-Input Multiplexer: Non-Inverting	16	N	D
MC74AC158	Quad 2-Input Multiplexer: Inverting	16	N	D
MC74AC160	Synchronous Presettable Binary-Coded-Decimal Decade Counter	16	N	D
MC74AC161	Synchronous Presettable Binary Counter	16	N	D
MC74AC162	Synchronous Presettable Binary-Coded-Decimal Decade Counter	16	N	D
MC74AC163	Synchronous Presettable Binary Counter	16	N	D
MC74AC174	Hex D Flip-Flop With Master Reset	16	N	D
MC74AC175	Quad D Flip-Flop	16	N	D
MC74AC190	Up/Down Counter With Preset and Ripple Clock	16	N	D
MC74AC194	4-Bit Bidirectional Universal Shift Register	16	N	D
MC74AC240	Octal Buffer/Line Driver: With 3-State Outputs	20	N	DW
MC74AC241	Octal Buffer/Line Driver: With 3-State Outputs	20	N	DW
MC74AC244	Octal Buffer/Line Driver: With 3-State Outputs	20	N	DW
MC74AC245	Octal Bidirectional Transceiver With 3-State Inputs/Outputs	20	N	DW
MC74AC251	8-Input Multiplexer: With 3-State Outputs	16	N	D
MC74AC253	Dual 4-Input Multiplexer With 3-State Outputs	16	N	DW
MC74AC256	Dual 4-Bit Addressable Latch	16	N	DW
MC74AC257	Quad 2-Input Multiplexer Non-Inverting With 3-State Outputs	16	N	D
MC74AC258	Quad 2-Input Multiplexer Inverting With 3-State Outputs	16	N	DW
MC74AC259	8-Bit Addressable Latch	16	N	D
MC74AC273	Octal D Flip-Flop	20	N	DW
MC74AC299	8-Input Universal Shift/Storage Register With Common Parallel I/O Pins: With 3-State Outputs	20	N	DW
MC74AC323	8-Input Universal Shift/Storage Register With Syn Reset/Common Parallel I/O Pins: With 3-State Outputs	20	N	DW
MC74AC350	4-Bit Shifter With 3-State	16	N	D
MC74AC352	Dual 4-Input Multiplexer	16	N	DW
MC74AC353	Dual 4-Input Multiplexer With 3-State Outputs	16	N	D
MC74AC373	Octal Transparent Latch With 3-State Outputs	20	N	DW
MC74AC374	Octal D Type Flip-Flop With 3-State Outputs	20	N	DW
MC74AC377	Octal D Flip-Flop With Clock Enable	20	N	DW
MC74AC378	6-Bit Parallel D Register With Enable	16	N	D
MC74AC533	Octal Transparent Latch/ With 3-State Outputs	20	N	DW
MC74AC534	Octal D Flip-Flop/ With 3-State Outputs	20	N	DW

3

**FACT** (continued)**Numeric Listing** (continued)

Device	Function	Pins	DIP	SM
MC74AC540	Octal Buffer/Line Driver: With 3-State Outputs	20	N	DW
MC74AC541	Octal Buffer/Line Driver: With 3-State Outputs	20	N	DW
MC74AC563	Octal D Latch With 3-State Outputs	20	N	DW
MC74AC564	Octal D Latch With 3-State Outputs	20	N	DW
MC74AC573	Octal D-Type Latch With 3-State Outputs	20	N	DW
MC74AC574	Octal D-Type Latch With 3-State Outputs	20	N	DW
MC74AC620	Octal Bidirectional Transceiver With 3-State Outputs	20	N	DW
MC74AC623	Octal Bidirectional Transceiver With 3-State Outputs	20	N	DW
MC74AC640	Octal Bidirectional Transceiver With 3-State Outputs	20	N	DW
MC74AC643	Octal Bidirectional Transceiver With 3-State Outputs	20	N	DW
MC74AC646	Octal Transceiver/Register With 3-State Outputs Non-Inverting	24	N	DW
MC74AC648	Octal Transceiver/Register With 3-State Outputs Inverting	24	N	DW
MC74AC652	Octal Bus Transceiver/Register With 3-State Outputs Non-Inverting	24	N	DW
MC74AC810	Quad 2-Input Exclusive NOR Gate	14	N	DW
MC74AC4020	14-Stage Binary Ripple Counter	16	N	D
MC74AC4040	12-Stage Binary Ripple Counter	16	N	D

**3****FACT — TTL Compatible****Numeric Listing**

MC74	Function	Pins	DIP	SM
MC74ACT00	Quad 2-Input NAND Gate	14	N	D
MC74ACT02	Quad 2-Input NOR Gate	14	N	D
MC74ACT04	Hex Inverter	14	N	D
MC74ACT05	Hex Inverter With Open Drain Output	14	N	D
MC74ACT08	Quad 2-Input AND Gate	14	N	D
MC74ACT10	Triple 3-Input NAND Gate	14	N	D
MC74ACT11	Triple 3-Input AND Gate	14	N	D
MC74ACT14	Hex Inverter Schmitt Trigger	14	N	D
MC74ACT20	Dual 4-Input NAND Gate	14	N	D
MC74ACT32	Quad 2-Input OR Gate	14	N	D
MC74ACT74	Dual D Flip-Flop	14	N	D
MC74ACT86	Quad 2-Input Exclusive OR Gate	14	N	D
MC74ACT109	Dual J-K Flip-Flop Positive Edge-Triggered With Set and Clear	16	N	D
MC74ACT112	Dual J-K Flip-Flop Negative Edge-Triggered	16	N	D
MC74ACT113	Dual J-K Flip-Flop Negative Edge-Triggered	14	N	D
MC74ACT125	Quad Buffer 3-State	14	N	D
MC74ACT126	Quad Buffer 3-State	14	N	D
MC74ACT132	Quad 2-Input NAND Schmitt Trigger	14	N	D
MC74ACT138	1-of-8 Decoder/Demux	16	N	D
MC74ACT139	Dual 1-of-4 Decoder/Demux	16	N	D

† = New Devices

## FACT — TTL Compatible (continued)

### Numeric Listing (continued)

MC74	Function	Pins	DIP	SM
MC74ACT151	1-of-8 Decoder/Multiplexer	16	N	D
MC74ACT153	Dual 4-Input Multiplexer	16	N	D
MC74ACT157	Quad 2-Input Multiplexer: Non-Inverting	16	N	D
MC74ACT158†	Quad 2-Input Multiplexer: Inverting	16	N	D
MC74ACT160	Synchronous Presettable Binary-Coded-Decimal Decade Counter	16	N	D
MC74ACT161	Synchronous Presettable Binary Counter	16	N	D
MC74ACT162	Synchronous Presettable Binary-Coded-Decimal Decade Counter	16	N	D
MC74ACT163	Synchronous Presettable Binary Counter	16	N	D
MC74ACT174	Hex D Flip-Flop With Master Reset	16	N	D
MC74ACT175	Quad D Flip-Flop	16	N	D
MC74ACT194	4-Bit Bidirectional Universal Shift Register	16	N	D
MC74ACT240	Octal Buffer/Line Driver: 3-State	20	N	DW
MC74ACT241	Octal Buffer/Line Driver: 3-State	20	N	DW
MC74ACT244	Octal Buffer/Line Driver: 3-State	20	N	DW
MC74ACT245	Octal Bidirectional Transceiver With 3-State Inputs/Outputs	20	N	DW
MC74ACT251	8-Input Multiplexer: 3-State	16	N	D
MC74ACT253	Dual 4-Input Multiplexer With 3-State Outputs	16	N	DW
MC74ACT256	Dual 4-Bit Addressable Latch	16	N	DW
MC74ACT257†	Quad 2-Input Multiplexer Non-Inverting With 3-State Outputs	16	N	D
MC74ACT258	Quad 2-Input Multiplexer Inverting 3-State	16	N	DW
MC74ACT259	8-Bit Addressable Latch	16	N	D
MC74ACT273	Octal D Flip-Flop	20	N	DW
MC74ACT299	8-Input Universal Shift/Storage Register With Common Parallel I/O Pins: 3-State	20	N	DW
MC74ACT323	8-Input Universal Shift/Storage Register With Syn Reset/Common Parallel I/O Pins: 3-State	20	N	DW
MC74ACT350	4-Bit Shifter With 3-State	16	N	D
MC74ACT352	Dual 4-Input Multiplexer	16	N	DW
MC74ACT353	Dual 4-Input Multiplexer With 3-State Outputs	16	N	D
MC74ACT373	Octal Transparent Latch With 3-State Outputs	20	N	DW
MC74ACT374	Octal D-Type Flip-Flop With 3-State Outputs	20	N	DW
MC74ACT377	Octal D Flip-Flop With Clock Enable	20	N	DW
MC74ACT378	6-Bit Parallel D Register With Enable	16	N	D
MC74ACT521	8-Bit Identity Comparator	20	N	DW
MC74ACT533	Octal Transparent Latch With 3-State Outputs	20	N	DW
MC74ACT534	Octal D Flip-Flop With 3-State Outputs	20	N	DW
MC74ACT540	Octal Buffer/Line Driver: 3-State Outputs	20	N	DW
MC74ACT541	Octal Buffer/Line Driver: 3-State Outputs	20	N	DW
MC74ACT563	Octal D Latch With 3-State Outputs	20	N	DW
MC74ACT564	Octal D Latch With 3-State Outputs	20	N	DW
MC74ACT573	Octal D-Type Latch With 3-State Outputs	20	N	DW

† = New Devices

3

**FACT — TTL Compatible** (continued)**Numeric Listing** (continued)

MC74	Function	Pins	DIP	SM
MC74ACT574	Octal D-Type Latch With 3-State Outputs	20	N	DW
MC74ACT620	Octal Bidirectional Transceiver With 3-State Outputs	20	N	DW
MC74ACT623	Octal Bidirectional Transceiver With 3-State Outputs	20	N	DW
MC74ACT640	Octal Bidirectional Transceiver With 3-State Outputs	20	N	DW
MC74ACT643	Octal Bidirectional Transceiver With 3-State Outputs	20	N	DW
MC74ACT646	Octal Transceiver/Register With 3-State Outputs, Non-Inverting	24	N	DW
MC74ACT648	Octal Transceiver/Register With 3-State Outputs, Inverting	24	N	DW
MC74ACT652	Octal Bus Transceiver/Register, Non-Inverting 3-State	24	N	DW
MC74ACT810	Quad 2-Input Exclusive NOR Gate	14	N	DW

† = New Devices

**3**

# MECL III

## MECL III

### Numeric Listing

Device	Function	Pins	DIP	SM*
MC1648**	Voltage Controlled Oscillator	14	P,L	D, FN
MC1650	Dual A/D Converter	16	L	
MC1651	Dual A/D Converter	16	L	
MC1658	Voltage Controlled Multivibrator	16	P,L	D, FN
MC1660	Dual 4-Input OR/NOR Gate	16	L	
MC1662	Quad 2-Input NOR Gate	16	L	
MC1670	Master-Slave Flip-Flop	16	L	
MC1672	Triple 2-Input Exclusive-OR Gate	16	L	
MC1692	Quad Line Receiver	16	L	

\*≤ 20-Pin DIP = 20-Pin PLCC; > 20-Pin DIP = 28-Pin PLCC; See Conversion Table on page 3.1-62

\*\*The MC1648 has a Non-Standard Conversion Table. For more information, refer to the Motorola MECL Data Book, DL122/D, REV 5.

3

## HTL/DTL Circuits

Motorola still supplies a large selection of HTL (High-Threshold Logic) and DTL (Diode-Transistor Logic) circuits. These are recommended primarily for replacement purposes. A list of available type numbers is given below.

### DTL Circuits

Device	Function
MC830	Expandable NAND Gate
MC832	Expandable Buffer
MC836	Hex Inverter
MC837	Hex Inverter
MC840	Hex Inverter (without input diodes)
MC844	Expandable Dual Power Gate
MC845	Clocked Flip-Flop
MC846	Quad 2-Input NAND Gate
MC849	Quad 2-Input NAND Gate
MC936	Hex Inverter
MC937	Hex Inverter
MC944	Expandable Dual Power Gate
MC945	Clocked Flip-Flop
MC946	Quad 2-Input NAND Gate
MC951	Monostable Multivibrator
MC952	Dual J-K Flip-Flop (common clock and CD Separate SD)
MC953	Dual J-K Flip-Flop (separate clock and SD, No CD)

### HTL Circuits

Device	Function
MC660	Expandable Dual 4-Input Gate (active pullup)
MC661	Expandable Dual 4-Input Gate (passive pullup)
MC662	Expandable Dual 4-Input Line Driver
MC663	Dual J-K Flip-Flop
MC664	Master-Slave R-S Flip-Flop
MC667	Dual Monostable Multivibrator
MC668	Quad 2-Input Gate (passive pullup)
MC669	Dual 4-Input Expander
MC670	Triple 3-Input Gate (passive pullup)
MC671	Triple 3-Input Gate (active pullup)
MC672	Quad 2-Input Gate (active pullup)
MC677	Hex Inverter With Strobe (active pullup)
MC678	Hex Inverter With Strobe (without output resistors)

# Ordering Information Device Nomenclatures

## LS – Low Power Schottky

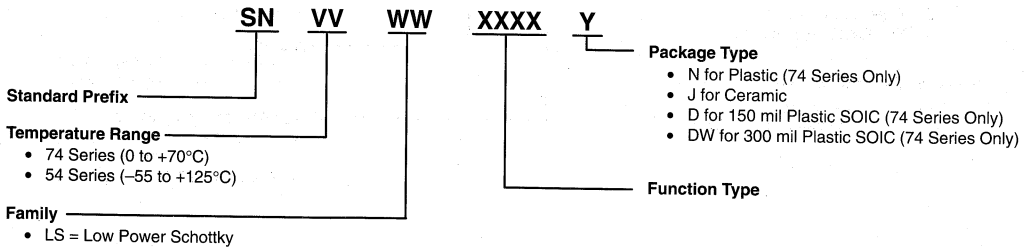

## FAST

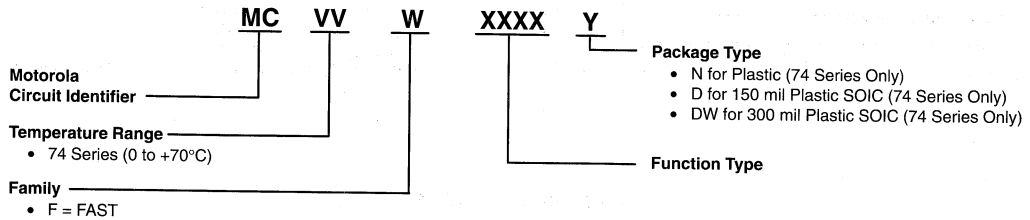

3

## MECL 10K, MECL 10H/100H

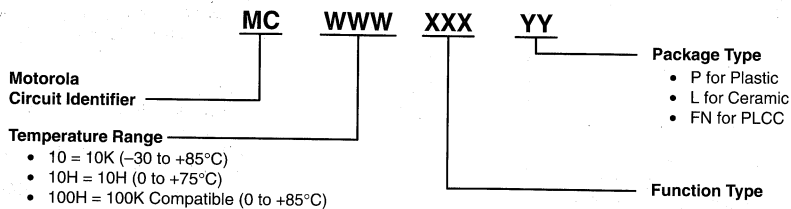

## ECLinPS, ECLinPS Lite

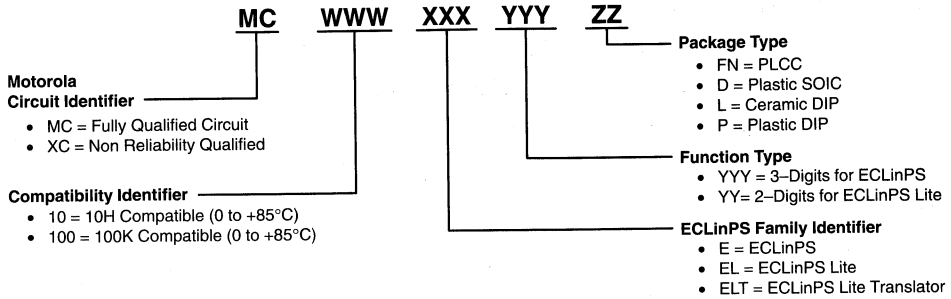

## Metal Gate 14000 Series CMOS

3

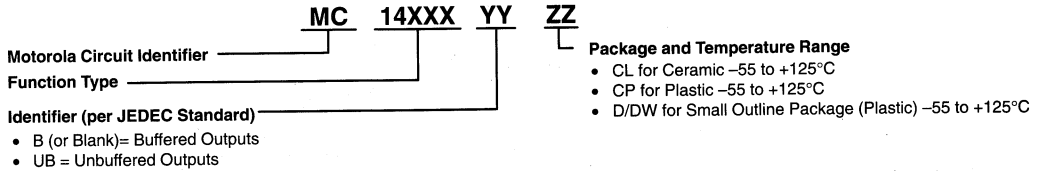

## High-Speed CMOS

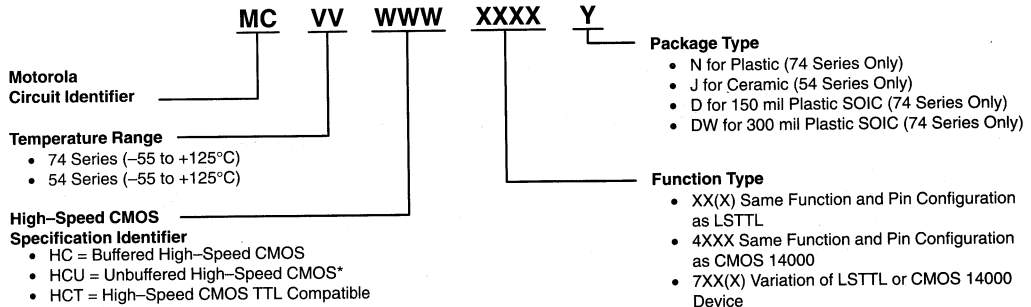

\*Not Available On All Devices

## FACT

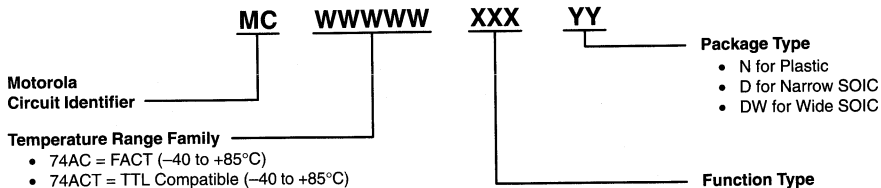

## SPECIAL LOGIC CIRCUITS

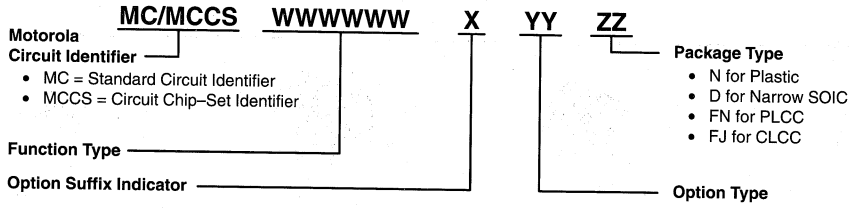

## MECL III/HTL/DTL

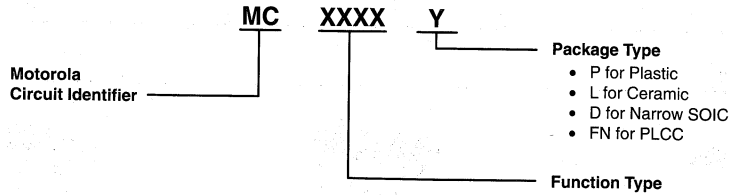

3

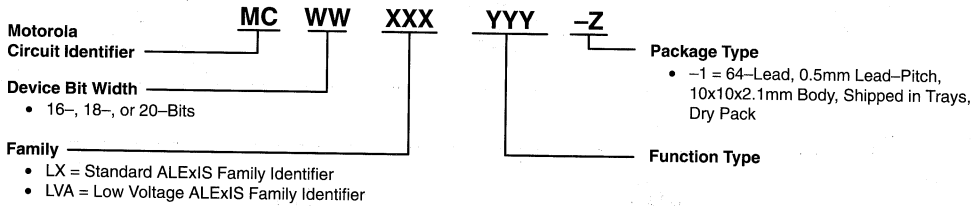

## ALEXIS PRODUCTS



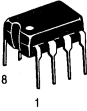
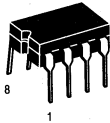

# Case Information

## 8-Pin Packages

			
<b>D SUFFIX</b> SOIC CASE 751-04	<b>P SUFFIX</b> PLASTIC CASE 626-05	<b>L SUFFIX</b> CERAMIC CASE 693-03	<b>SD SUFFIX</b> SSOP CASE 940-02

## 14-Pin Packages

3

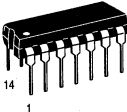
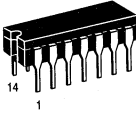
		
<b>D SUFFIX</b> SOIC CASE 751A-03	<b>P,N SUFFIX</b> PLASTIC CASE 646-06	<b>L,J SUFFIX</b> CERAMIC CASE 632-08

## 16-Pin Packages

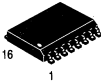
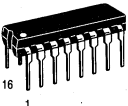
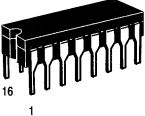
	
<b>D SUFFIX</b> SOIC CASE 751B-05	<b>DW SUFFIX</b> SOIC CASE 751G-02
	
<b>P,N SUFFIX</b> PLASTIC CASE 648-08	<b>L,J SUFFIX</b> CERAMIC CASE 620-10

**18-Pin Packages**

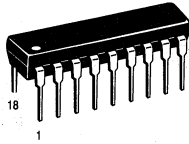

**P,N SUFFIX**  
**PLASTIC**  
**CASE 707-02**

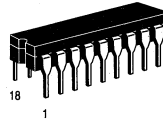

**L,J SUFFIX**  
**CERAMIC**  
**CASE 726-04**

**20-Pin Packages**

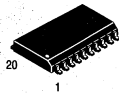

**DW SUFFIX**  
**SOIC**  
**CASE 751D-04**

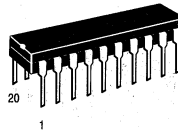

**P,N SUFFIX**  
**PLASTIC**  
**CASE 738-03**

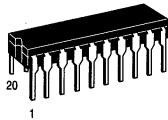

**L,J SUFFIX**  
**CERAMIC**  
**CASE 732-03**

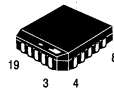

**FN SUFFIX**  
**PLASTIC LEADLESS**  
**CHIP CARRIER (PLCC)**  
**CASE 775-02**

**3**

**22-Pin Packages**

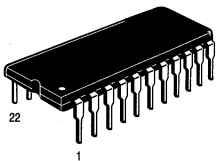

**N SUFFIX**  
**PLASTIC**  
**CASE 708-04**

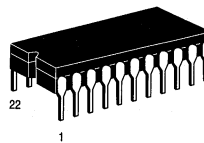

**J SUFFIX**  
**CERAMIC**  
**CASE 736-05**

### 24-Pin Packages

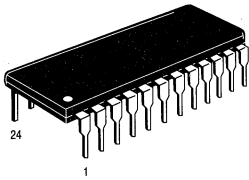

**N SUFFIX**  
PLASTIC  
CASE 709-02

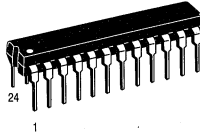

**P,N SUFFIX**  
PLASTIC  
CASE 724-03

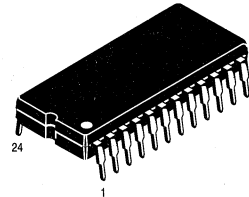

**P,N SUFFIX**  
PLASTIC  
CASE 649-03  
(PW FOR 10H181 ONLY)

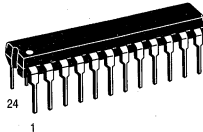

**L,J SUFFIX**  
CERAMIC  
CASE 758-02

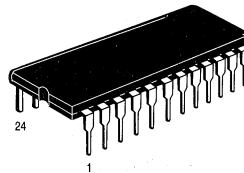

**L,J SUFFIX**  
CERAMIC  
CASE 623-05  
(LW FOR 10H181 ONLY)

3

### 28-Pin Packages

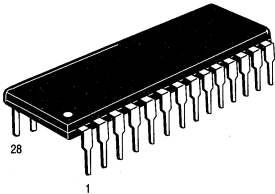

**N SUFFIX**  
PLASTIC  
CASE 710-02

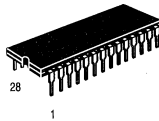

**J SUFFIX**  
CERAMIC  
CASE 733-04

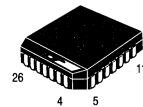

**FN SUFFIX**  
PLASTIC LEADLESS  
CHIP CARRIER (PLCC)  
CASE 776-02

**40-Pin Packages**

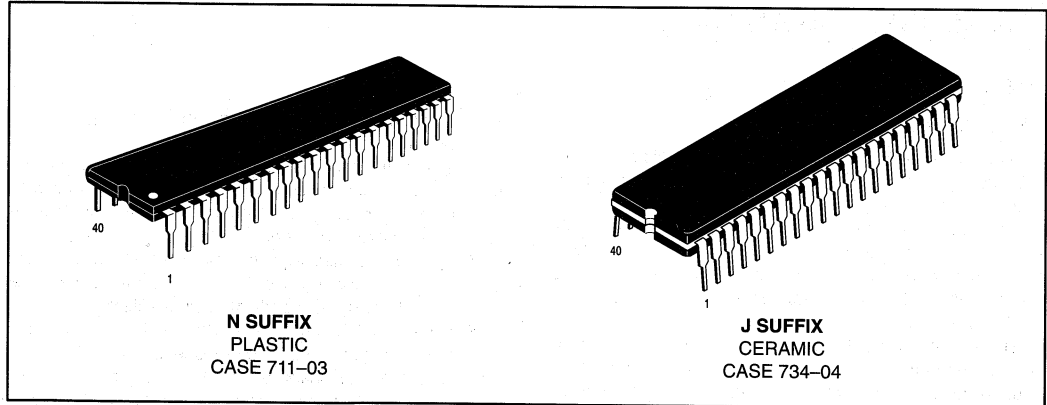

**48-Pin Package**

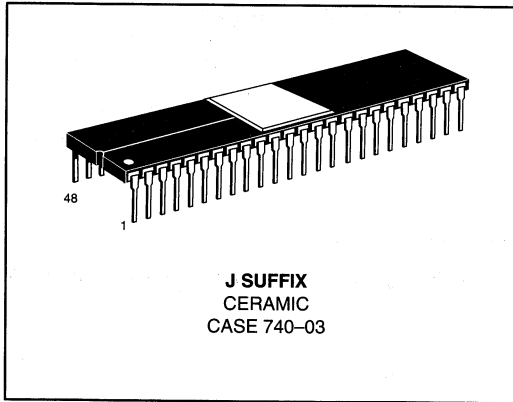

**52-Pin Package**

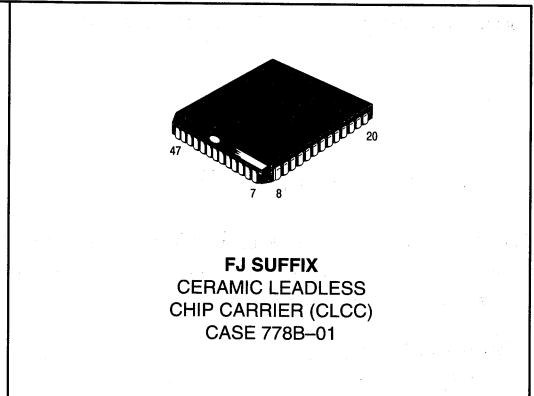

**3**

**64-Pin Package**

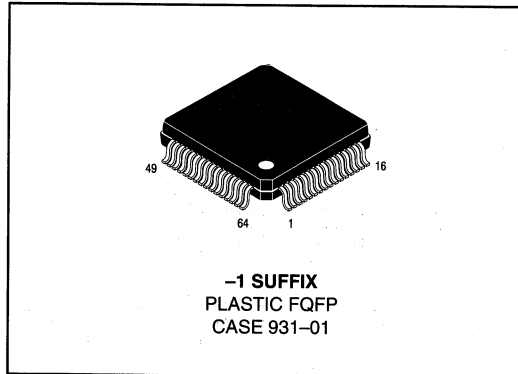

**68-Pin Package**

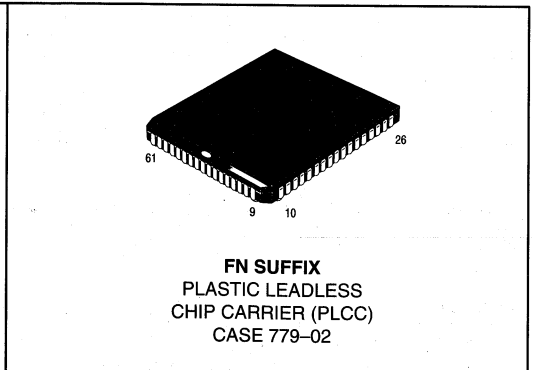

# Packaging Information

## Surface Mount

### Why Surface Mount?

Surface Mount Technology is now being utilized to offer answers to many problems that have been created in the use of insertion technology.

Limitations have been reached with insertion packages and PC board technology. Surface Mount Technology offers the opportunity to continue to advance the state-of-the-art designs that cannot be accomplished with Insertion Technology.

Surface Mount Packages allow more optimum device performance with the smaller Surface Mount configuration. Internal lead lengths, parasitic capacitance and inductance that placed limitations on chip performance have been reduced.

The lower profile of Surface Mount Packages allows more boards to be utilized in a given amount of space. They are

stacked closer together and utilize less total volume than insertion populated PC boards.

Printed circuit costs are lowered with the reduction of the number of board layers required. The elimination or reduction of the number of plated through holes in the board, contributes significantly to lower PC board prices.

Automatic placement equipment is available that can place Surface Mount components at the rate of a few thousand per hour to hundreds of thousands of components per hour.

Surface Mount Technology is cost effective, allowing the manufacturer the opportunity to produce smaller units and/or offer increased functions with the same size product.

Surface Mount assembly does not require the preparation of components that are common on insertion technology lines. Surface Mount components are sent directly to the assembly line, eliminating an intermediate step.

3

## Pin Conversion Tables

### Dual-in-Line Package to PLCC Pin Conversion Data

The following table gives the equivalent I/O pinouts of Dual-In-Line Package (DIP) configuration and Plastic Leaded Chip Carrier (PLCC) packages.\*

#### Conversion Tables

8 PIN DIP	1	2	3	4	5	6	7	8
20 PIN PLCC	2	5	7	10	12	15	17	20

14 PIN DIP	1	2	3	4	5	6	7	8	9	10	11	12	13	14
20 PIN PLCC	2	3	4	6	8	9	10	12	13	14	16	18	19	20

16 PIN DIP	1	2	3	4	5	6	7	8	9	10	11	12	13	14	15	16
20 PIN PLCC	2	3	4	5	7	8	9	10	12	13	14	15	17	18	19	20

20 PIN DIP	1	2	3	4	5	6	7	8	9	10	11	12	13	14	15	16	17	18	19	20
20 PIN PLCC	1	2	3	4	5	6	7	8	9	10	11	12	13	14	15	16	17	18	19	20

24 PIN DIP	1	2	3	4	5	6	7	8	9	10	11	12	13	14	15	16	17	18	19	20	21	22	23	24
28 PIN PLCC	2	3	4	5	6	7	9	10	11	12	13	14	16	17	18	19	20	21	23	24	25	26	27	28

\* The MC1648 has a Non-Standard Conversion Table. For more information, refer to the Motorola MECL Data Book, DL122/D.

# Tape and Reel

## Standard Bipolar Logic Integrated Circuits

Motorola has now added the convenience of Tape and Reel packaging for Motorola's growing family of standard Integrated Circuit products. The packaging fully conforms to

the latest EIA RS-481A specification. The antistatic embossed tape provides a secure cavity sealed with a peel-back cover tape.

### Mechanical Polarization

#### PLCC Devices

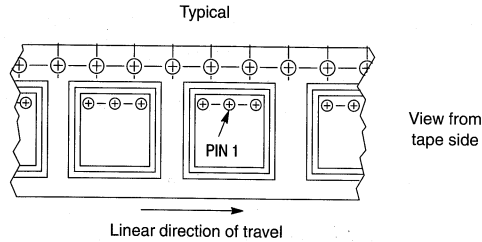

#### SOIC Devices

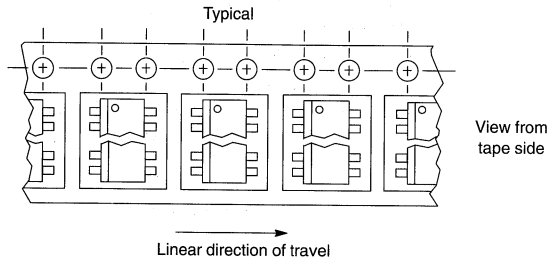

3

### General Information

— Reel Size 13 inch (330 mm) Suffix: R2 — Units/Reel 500 to 5000 (see table)  
 — Tape Width 12 mm to 24 mm (see table)

### Ordering Information

To order devices which are to be delivered in Tape and Reel, add the suffix R2 to the device number being ordered.

### Tape and Reel Data

Device Type	Tape Width (mm)	Device/Reel	Reel Size (inch)	Min Lot Size Per Part No. Tape and Reel
PLCC-20	16	1,000	13	3,000
PLCC-28	24	500	13	500
SO-8	12	2,500	13	5,000
SO-14	16	2,500	13	5,000
SO-16	16	2,500	13	5,000
SO-16 Wide	16	1,000	13	5,000
SO-20 Wide	24	1,000	13	5,000

# Logic Literature Listing

For additional information, refer to the following Motorola Logic Documents, available through the Literature Distribution Center.

## LOGIC NEW PRODUCT CALENDAR

BR1332/D ..... Logic New Product Calendar

## SELECTOR GUIDES

SG73/D ..... Motorola Semiconductor Master Selection Guide  
SG127/D ..... Surface Mount Products Selector Guide  
SG365/D ..... Timing Solutions Folder Selector Guide  
SG366/D ..... TTL, ECL, CMOS and Special Logic Circuits Selector Guide

## DATA BOOKS

BR1330/D ..... ECLinPS Lite™ (Single Gate ECL Devices and Translators)  
BR1333/D ..... Timing Solutions  
BR1334/D ..... High Performance Frequency Control Products  
DL121/D ..... FAST and LS TTL Data  
DL122/D ..... MECL Data  
DL129/D ..... High-Speed CMOS Data  
DL131/D ..... CMOS Logic Data  
DL138/D ..... FACT Data  
DL140/D ..... High Performance ECL Data – ECLinPS and ECLinPS Lite

## DESIGN HANDBOOKS

HB205/D ..... MECL Systems Design Handbook

## APPLICATION NOTES

AN1091/D ..... Low Skew Clock Drivers and Their System Design Considerations  
AN1092/D ..... Driving High Capacitance DRAMs in an ECL System  
AN1400/D ..... H64x Clock Driver I/O SPICE Modelling Kit  
AN1401/D ..... Using SPICE to Analyze the Effects of Board Layout on System Skew When Designing With the MC10/100640 Family of Clock Drivers  
AN1402/D ..... MC10/100H600 Translator Family I/O SPICE Modelling Kit  
AN1403/D ..... FACT™ I/O Model Kit  
AN1404/D ..... ECLinPS™ Circuit Performance at Non-Standard VIH Levels  
AN1405/D ..... ECL Clock Distribution Techniques  
AN1406/D ..... Designing With PECL (ECL at +5.0V)  
AN1407/D ..... Performance Testing With the ALExIS™ Mini-Evaluation Boards  
AN1408/D ..... Power Dissipation for Active SCSI Terminators  
AN1410/D ..... Configuring and Applying the MC54/74HC4046A Phase-Locked Loop  
AN1503/D ..... ECLinPS™ I/O SPICE Modelling Kit  
AN1504/D ..... Metastability and the ECLinPS™ Family

## OTHER LITERATURE

BR1331/D ..... ALExIS – Advanced Low-Power Expandable Interface Solutions Folder

### Literature Distribution Centers:

USA: Motorola Literature Distribution; P.O. Box 20912; Phoenix, Arizona 85036.

EUROPE: Motorola Ltd.; European Literature Centre; 88 Tanners Drive, Blakelands, Milton Keynes, MK14 5BP, England.

JAPAN: Nippon Motorola Ltd.; 4-32-1, Nishi-Gotanda, Shinagawa-ku, Tokyo 141, Japan.

ASIA PACIFIC: Motorola Semiconductors H.K. Ltd.; Silicon Harbour Center, No. 2 Dai King Street, Tai Po Industrial Estate, Tai Po, N.T., Hong Kong.

3

# Amplifiers and Comparators

---

## In Brief . . .

For over two decades, Motorola has continually refined and updated integrated circuit technologies, analog circuit design techniques and processes in response to the needs of the marketplace. The enhanced performance of newer operational amplifiers and comparators has come through innovative application of these technologies, designs and processes. Some early designs are still available but are giving way to the new, higher performance operational amplifier and comparator circuits. Motorola has pioneered in JFET inputs, low temperature coefficient input stages, Miller loop compensation, all NPN output stages, dual-doublet frequency compensation and analog "in-the-package" trimming of resistors to produce superior high performance operational amplifiers and comparators, operating in many cases from a single supply with low input offset, low noise, low power, high output swing, high slew rate and high gain-bandwidth product at reasonable cost to the customer.

Present day operational amplifiers and comparators find applications in all market segments including motor controls, instrumentation, aerospace, automotive, telecommunications, medical, and consumer products.

	<b>Page</b>
Operational Amplifiers .....	4.1-2
Single .....	4.1-2
Dual .....	4.1-3
Quad .....	4.1-5
High Frequency Amplifiers .....	4.1-7
AGC .....	4.1-7
Miscellaneous Amplifiers .....	4.1-8
Bipolar .....	4.1-8
CMOS .....	4.1-8
Comparators .....	4.1-9
Single .....	4.1-9
Dual .....	4.1-9
Quad .....	4.1-10



## Operational Amplifiers

Motorola offers a broad line of bipolar operational amplifiers to meet a wide range of applications. From low-cost industry-standard types to high precision circuits, the span encompasses a large range of performance capabilities. These Linear integrated circuits are available as single, dual and quad monolithic devices in a variety of temperature ranges and package styles. Most devices may be obtained in unencapsulated "chip" form as well. For price and delivery information on chips, please contact your Motorola Sales Representative or Distributor.

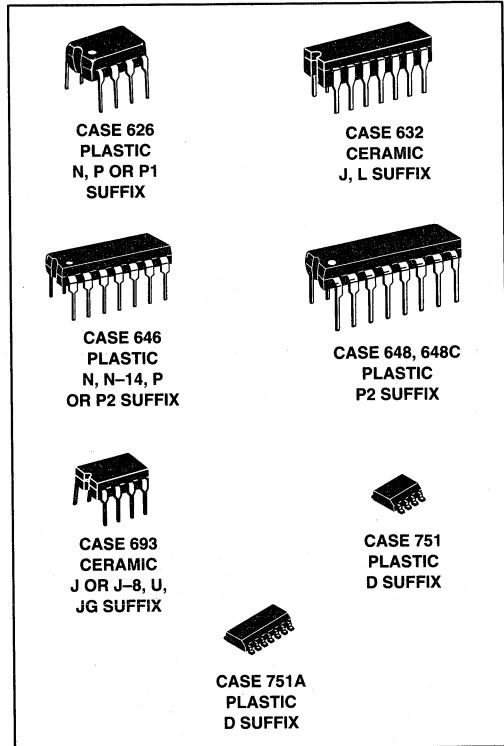

**Table 1. Single Operational Amplifiers**

Device	I <sub>B</sub> (μA) Max	V <sub>IO</sub> (mV) Max	TC <sub>VIO</sub> (μV/°C) Typ	I <sub>O</sub> (nA) Max	A <sub>vol</sub> (V/mV) Min	BW (A <sub>v</sub> = 1) (MHz) Typ	SR (A <sub>v</sub> = 1) (V/μs) Typ	Supply Voltage (V)		Description	Suffix/ Package
								Min	Max		
<b>Noncompensated</b>											
<b>Commercial Temperature Range (0°C to +70°C)</b>											
LM301A	0.25	7.5	10	50	25	1.0	0.5	± 3.0	± 18	General Purpose	N/626, J/693
LM308A	7.0	0.5	5.0	1.0	80	1.0	0.3	± 3.0	± 18	Precision	N/626
MC1748C	0.5	6.0	15	200	20	1.0	0.5	± 3.0	± 18	General Purpose	P1
<b>Industrial Temperature Range (-25°C to +85°C)</b>											
LM201A	0.075	2.0	10	10	50	1.0	0.5	± 3.0	± 22	General Purpose	N/626, J/693
<b>Military Temperature Range (-55°C to +125°C)</b>											
LM101A	0.075	2.0	10	10	50	1.0	0.5	± 3.0	± 22	General Purpose	J/693
<b>Internally Compensated</b>											
<b>Commercial Temperature Range (0°C to +70°C)</b>											
LF351	200 pA	10	10	100 pA	25	4.0	13	± 5.0	± 18	JFET Input	N/626
LF356	200 pA	10	5.0	50 pA	50	2.0	15	± 5.0	± 18	JFET Input	J/693
LF356B	100 pA	5.0	5.0	20 pA	50	5.0	12	± 5.0	± 22	JFET Input	J/693
LF357	200 pA	10	5.0	50 pA	50	3.0	75	± 5.0	± 18	Wideband FET Input	J/693
LF357B	100 pA	5.0	5.0	20 pA	50	20	50	± 5.0	± 22	JFET Input	J/693
LF411C	200 pA	2.0	10	100 pA	25	8.0	25	+ 5.0	± 22	JFET Input, Low Offset, Low Drift	N/626, D/751

**Table 1. Single Operational Amplifiers**

Device	$I_{IB}$	$V_{IO}$	$TC_{VIO}$	$I_{IO}$	$A_{Vol}$	BW	SR	Supply Voltage		Description	Suffix/ Package
	( $\mu$ A) Max	(mV) Max	( $\mu$ V/ $^{\circ}$ C) Typ	(nA) Max	(V/mV) Min	( $A_V = 1$ ) (MHz) Typ	( $A_V = 1$ ) (V/ $\mu$ s) Typ	Min	Max		
<b>Internally Compensated</b>											
<b>Commercial Temperature Range (0°C to +70°C)</b>											
LF441C	100 pA	5.0	10	50 pA	25	2.0	6.0	$\pm 5.0$	$\pm 18$	Low Power JFET Input	N/626
LM11C	100 pA	0.6	2.0	10 pA	250	1.0	0.3	$\pm 3.0$	$\pm 20$	Precision	N/626
LM11CL	200 pA	5.0	3.0	25 pA	50	1.0	0.3	$\pm 3.0$	$\pm 20$	Precision	N/626
LM307	0.25	7.5	10	50	25	1.0	0.5	$\pm 3.0$	$\pm 18$	General Purpose	N/626
MC1436	0.04	10	12	10	70	1.0	2.0	$\pm 15$	$\pm 34$	High Voltage	U
MC1741C	0.5	6.0	15	200	20	1.0	0.5	$\pm 3.0$	$\pm 18$	General Purpose	P1, U
MC1776C	0.003	6.0	15	3.0	100	1.0	0.2	$\pm 1.2$	$\pm 18$	$\mu$ Power, Programmable	P1, U
MC3476	0.05	6.0	15	25	50	1.0	0.2	$\pm 1.5$	$\pm 18$	Low Cost	P1, U
										$\mu$ Power, Programmable	
MC34001	200 pA	10	10	100 pA	25	4.0	13	$\pm 5.0$	$\pm 18$	JFET Input	P/626, U
MC34001B	200 pA	5.0	10	100 pA	50	4.0	13	$\pm 5.0$	$\pm 18$	JFET Input	P/626, U
MC34071	0.5	5.0	10	75	25	4.5	10	+3.0	+44	High Performance,	P/626, U
MC34071A	500 nA	3.0	10	50	50	4.5	10	+3.0	+44	Single Supply	P/626, U
MC34080	200 pA	1.0	10	100 pA	25	16	55	$\pm 5.0$	$\pm 22$	Decompensated	P/626, U
MC34081	200 pA	1.0	10	100 pA	25	8.0	30	$\pm 5.0$	$\pm 22$	High Speed JFET Input	P/626, U
MC34181	0.1 nA	2.0	10	0.05	25	4.0	10	$\pm 2.5$	$\pm 18$	Low Power JFET Input	P/626
TL071AC	200 pA	6.0	10	50 pA	50	4.0	13	$\pm 5.0$	$\pm 18$	Low Noise JFET Input	P/626, JG
TL071C	200 pA	10	10	50 pA	25	4.0	13	$\pm 5.0$	$\pm 18$	Low Noise JFET Input	P/626, JG
TL081AC	200 pA	6.0	10	100 pA	50	4.0	13	$\pm 5.0$	$\pm 18$	JFET Input	P/626, JG
TL081C	400 pA	15	10	200 pA	25	4.0	13	$\pm 5.0$	$\pm 18$	JFET Input	P/626, JG
<b>Automotive Temperature Range (-40°C to +85°C)</b>											
MC33071	0.5	5.0	10	75	25	4.5	10	+3.0	+44	High Performance,	P/626, U
MC33071A	500 nA	3.0	10	50	50	4.5	10	+3.0	+44	Single Supply	P/626, U
MC33171	0.1	4.5	10	20	50	1.8	2.1	+3.0	+44	Low Power Single Supply	P/626
MC33181	0.1 nA	2.0	10	0.05	25	4.0	10	$\pm 2.5$	$\pm 18$	Low Power JFET Input	P/626
<b>Extended Automotive Temperature Range (-40°C to +105°C)</b>											
MC33201	200 nA	6.0	2.0	50	50	2.2	1.0	+1.8	+12	Low V Rail-to-Rail™	P/626, D/751
<b>Military Temperature Range (-55°C to +125°C)</b>											
MC1536	0.02	5.0	10	3.0	100	1.0	2.0	$\pm 15$	$\pm 40$	High Voltage	U
MC1741	0.5	5.0	15	200	50	1.0	0.5	$\pm 3.0$	$\pm 22$	General Purpose	U
MC1776	0.0075	5.0	15	3.0	200	1.0	0.2	$\pm 1.2$	$\pm 18$	$\mu$ Power, Programmable	L
MC35001B	100 pA	5.0	10	50 pA	50	4.0	13	$\pm 5.0$	$\pm 22$	JFET Input	U
MC35071	0.5	5.0	10	75	25	4.5	10	+3.0	+44	High Performance,	U
MC35071A	500 nA	3.0	10	50	50	4.5	10	+3.0	+44	Single Supply	U
MC35080	200 pA	1.0	10	100 pA	25	16	55	$\pm 5.0$	$\pm 22$	Decompensated	U
MC35081	200 pA	1.0	10	100 pA	25	8.0	30	$\pm 5.0$	$\pm 22$	High Speed JFET Input	U
MC35171	0.1	4.5	10	20	50	1.8	2.1	+3.0	+44	Low Power Single Supply	U
TL081M	200 pA	6.0	10	100 pA	25	4.0	13	$\pm 5.0$	$\pm 18$	JFET Input	JG

4

**Table 2. Dual Operational Amplifiers**

Device	$I_{IB}$	$V_{IO}$	$TC_{VIO}$	$I_{IO}$	$A_{Vol}$	BW	SR	Supply Voltage		Description	Suffix/ Package
	( $\mu$ A) Max	(mV) Max	( $\mu$ V/ $^{\circ}$ C) Typ	(nA) Max	(V/mV) Min	( $A_V = 1$ ) (MHz) Typ	( $A_V = 1$ ) (V/ $\mu$ s) Typ	Min	Max		
<b>Internally Compensated</b>											
<b>Commercial Temperature Range (0°C to +70°C)</b>											
LF353	200 pA	10	10	100 pA	25	4.0	13	$\pm 5.0$	$\pm 18$	JFET Input	N/626

**Table 2. Dual Operational Amplifiers**

Device	$I_B$	$V_{IO}$	$TC_{VIO}$	$I_O$	$A_{vol}$	BW	SR	Supply Voltage		Description	Suffix/ Package
	( $\mu A$ ) Max	(mV) Max	( $\mu V/^\circ C$ ) Typ	(nA) Max	(V/mV) Min	(MHz) Typ	(V/ $\mu s$ ) Typ	Min	Max		
LF412C	200 pA	3.0	10	100 pA	25	4.0	13	+ 5.0	$\pm 18$	JFET Input, Low Offset, Low Drift	N/626, D/751
LF442C	100 pA	5.0	10	50 pA	25	2.0	6.0	$\pm 5.0$	$\pm 18$	Low Power JFET Input	N/626
LM358	0.25	6.0	7.0	50	25	1.0	0.6	$\pm 1.5$	$\pm 18$	Single Supply,	N/626, J/693
								+ 3.0	+ 36	Low Power Consumption	
LM833	1.0	5.0	2.0	200	31.6	15	7.0	$\pm 2.5$	$\pm 18$	Low Noise, Audio	N/626
MC1458	0.5	6.0	10	200	20	1.1	0.8	$\pm 3.0$	$\pm 18$	Dual MC1741	P1, U
MC1458C	0.7	10	10	300	20	1.1	0.8	$\pm 3.0$	$\pm 18$	General Purpose	P1
MC1747C	0.5	6.0	10	200	25	1.0	0.5	$\pm 3.0$	$\pm 18$	Dual MC1741	L, P2
MC3458	0.5	10	7.0	50	20	1.0	0.6	$\pm 1.5$	$\pm 18$	Split Supplies	P1, U
								+ 3.0	+ 36	Single Supply	
										Low Crossover Distortion	
MC4558AC	0.5	5.0	10	200	50	2.8	1.6	$\pm 3.0$	$\pm 22$	High Frequency	P1
MC4558C	0.5	6.0	10	200	20	2.8	1.6	$\pm 3.0$	$\pm 18$	High Frequency	P1, U
MC34002	100 pA	10	10	100 pA	25	4.0	13	$\pm 5.0$	$\pm 18$	JFET Input	P/626
MC34002B	100 pA	5.0	10	70 pA	25	4.0	13	$\pm 5.0$	$\pm 18$	JFET Input	P/626
MC34072	0.5	5.0	10	75	25	4.5	10	+ 3.0	+ 44	High Performance,	P/626, U
MC34072A	500 nA	3.0	10	50	50	4.5	10	+ 3.0	+ 44	Single Supply	P/626, U
MC34082	200 pA	3.0	10	100 pA	25	8.0	30	$\pm 5.0$	$\pm 22$	High Speed JFET Input	P/626
MC34083	200 pA	3.0	10	100 pA	25	16	55	$\pm 5.0$	$\pm 22$	Decompensated	P/626
MC34182	0.1 nA	3.0	10	0.05	25	4.0	10	$\pm 2.5$	$\pm 18$	Low Power JFET Input	P/626
TL062AC	200 pA	6.0	10	100 pA	4.0	2.0	6.0	$\pm 2.5$	$\pm 18$	Low Power JFET Input	P/626
TL062C	200 pA	15	10	200 pA	4.0	2.0	6.0	$\pm 2.5$	$\pm 18$	Low Power JFET Input	P/626
TL072AC	200 pA	6.0	10	50 pA	50	4.0	13	$\pm 5.0$	$\pm 18$	Low Noise JFET Input	P/626, JG/693
TL072C	200 pA	10	10	50 pA	25	4.0	13	$\pm 5.0$	$\pm 18$	Low Noise JFET Input	P/626, JG/693
TL082AC	200 pA	6.0	10	100 pA	50	4.0	13	$\pm 5.0$	$\pm 18$	JFET Input	P/626, JG/693
TL082C	400 pA	15	10	200 pA	25	4.0	13	$\pm 5.0$	$\pm 18$	JFET Input	P/626, JG/693
<b>Industrial Temperature Range (-25°C to +85°C)</b>											
LM258	0.15	5.0	10	30	50	1.0	0.6	$\pm 1.5$	$\pm 18$	Split or Single Supply Op Amp	N/626, J/693
								+ 3.0	+ 36		
<b>Automotive Temperature Range (-40°C to +85°C)</b>											
LM2904	0.25	7.0	7.0	50	100 typ	1.0	0.6	$\pm 1.5$	$\pm 13$	Split Supplies	N/626, J/693
								+ 3.0	+ 26	Single Supply	
MC3358	5.0	8.0	10	75	20	1.0	0.6	$\pm 1.5$	$\pm 18$	Split Supplies	P1/626
								+ 3.0	+ 36	Single Supply	
MC33072	0.50	5.0	10	75	25	4.5	10	+ 3.0	+ 44	High Performance,	P/626, U
MC33072A	500 nA	3.0	10	50	50	4.5	10	+ 3.0	+ 44	Single Supply	P/626, U
MC33076	0.5	4.0	2.0	70	25	7.4	2.6	$\pm 2.0$	$\pm 18$	High Output Current	P1/626 P2/648C
MC33077	1.0	1.0	2.0	180	150	37	11	$\pm 2.5$	$\pm 18$	Low Noise	P/626
MC33078	750 nA	2.0	2.0	150	31.6	16	7.0	$\pm 5.0$	$\pm 18$	Low Noise	N/626
MC33102											
(Awake)	500 nA	2.0	1.0	6.0	50	4.0	1.0	$\pm 2.5$	$\pm 18$	Sleepmode™	P/626,
(Sleep)	50 nA	2.0	1.0	6.0	25	0.3	0.1	$\pm 2.5$	$\pm 18$	Micropower	D/751
MC33172	0.10	4.5	10	20	50	1.8	2.1	+ 3.0	+ 44	Low Power Single Supply	P/626
MC33178	0.5	3.0	2.0	50	50	5.0	2.0	$\pm 2.0$	$\pm 18$	High Output Current	P/626
MC33182	0.1 nA	3.0	10	0.05	25	4.0	10	$\pm 2.5$	$\pm 18$	Low Power JFET Input	P/626
MC33272	650 nA	1.0	0.56	25 nA	31.6	5.5	11.5	$\pm 1.5$	$\pm 18$	High Performance	P/626
MC33282	100 pA	200 $\mu V$	5.0	50 pA	50	30	12	$\pm 2.5$	$\pm 18$	Low Input Offset JFET	P/646
TL062V	200 pA	6.0	10	100 pA	4.0	2.0	6.0	$\pm 2.5$	$\pm 18$	Low Power JFET Input	P/626

4

**Table 2. Dual Operational Amplifiers**

Device	I <sub>B</sub> ( $\mu$ A) Max	V <sub>IO</sub> (mV) Max	TC <sub>VIO</sub> ( $\mu$ V/ $^{\circ}$ C) Typ	I <sub>IO</sub> (nA) Max	A <sub>vol</sub> (V/mV) Min	BW (A <sub>v</sub> = 1) (MHz) Typ	SR (A <sub>v</sub> = 1) (V/ $\mu$ s) Typ	Supply Voltage (V)		Description	Suffix/ Package
								Min	Max		
<b>Extended Automotive Temperature Range (-40°C to +105°C)</b>											
MC33202	200 nA	6.0	2.0	50	50	2.2	1.0	+1.8	+12	Low V Rail-to-Rail™	P/626, D/751
<b>Extended Automotive Temperature Range (-40°C to +125°C)</b>											
TCA0372	500 nA	15	20	50	30	1.1	1.4	+5.0	+36	Power Op Amp Single Supply	DP1/626 DP2/648
<b>Military Temperature Range (-55°C to +125°C)</b>											
LM158	0.15	5.0	10	30	50	1.0	0.6	$\pm$ 1.5 +3.0	$\pm$ 18 +36	Split Supplies Single Supply Low Power Consumption	J/693
MC1558	0.5	5.0	10	200	50	1.1	0.8	$\pm$ 3.0	$\pm$ 22	Dual MC1741	U
MC1747	0.5	5.0	10	200	50	1.0	0.5	$\pm$ 3.0	$\pm$ 22	Dual MC1741	L
MC3558	0.5	5.0	10	50	50	1.0	0.6	$\pm$ 1.5 +3.0	$\pm$ 18 +36	Split Supplies Single Supply	U
MC4558	0.5	5.0	10	200	50	2.8	1.6	$\pm$ 3.0	$\pm$ 22	High Frequency	U
MC35002	100 pA	10	10	100 pA	25	4.0	13	$\pm$ 5.0	$\pm$ 22	JFET Input	U
MC35002B	100 pA	5.0	10	50 pA	50	4.0	13	$\pm$ 5.0	$\pm$ 22	JFET Input	U
MC35072	0.5	5.0	10	75	25	4.5	10	+3.0	+44	High Performance,	U
MC35072A	500 nA	3.0	10	50	50	4.5	10	+3.0	+44	Single Supply	U
MC35172	0.1	4.5	10	20	50	1.8	2.1	+3.0	+44	Low Power Single Supply	U
TL062M	200 pA	6.0	10	100 pA	4.0	2.0	6.0	$\pm$ 2.5	$\pm$ 18	Low Power JFET Input	JG
TL072M	200 pA	6.0	10	50 pA	35	4.0	13	$\pm$ 5.0	$\pm$ 18	Low Noise JFET Input	JG
TL082M	200 pA	6.0	10	100 pA	25	4.0	13	$\pm$ 5.0	$\pm$ 18	JFET Input	JG

4

**Table 3. Quad Operational Amplifiers**

Device	I <sub>B</sub> ( $\mu$ A) Max	V <sub>IO</sub> (mV) Max	TC <sub>VIO</sub> ( $\mu$ V/ $^{\circ}$ C) Typ	I <sub>IO</sub> (nA) Max	A <sub>vol</sub> (V/mV) Min	BW (A <sub>v</sub> = 1) (MHz) Typ	SR (A <sub>v</sub> = 1) (V/ $\mu$ s) Typ	Supply Voltage (V)		Description	Suffix/ Package
								Min	Max		
<b>Internally Compensated</b>											
<b>Commercial Temperature Range (0°C to +70°C)</b>											
LF347	200 pA	10	10	100 pA	25	4.0	13	$\pm$ 5.0	$\pm$ 18	JFET Input	N/646
LF347B	200 pA	5.0	10	100 pA	50	4.0	13	$\pm$ 5.0	$\pm$ 18	JFET Input	N/646
LF444C	100 pA	10	10	50 pA	25	2.0	6.0	$\pm$ 5.0	$\pm$ 18	Low Power JFET Input	N/646
LM324	0.25	6.0	7.0	50	25	1.0	0.6	$\pm$ 1.5 +3.0	$\pm$ 16 +32	Low Power Consumption	J/632, N/646
LM348	0.2	6.0	—	50	25	1.0	0.5	$\pm$ 3.0	$\pm$ 18	Quad MC1741	J/632, N/646
MC3401/ LM3900	0.3	—	—	—	1.0	5.0	0.6	$\pm$ 1.5 +3.0	$\pm$ 18 +36	Norton Input	J/632, N/646
MC3403	0.5	10	7.0	50	20	1.0	0.6	$\pm$ 1.5 +3.0	$\pm$ 18 +36	No Crossover Distortion	L, P/646
MC4741C	0.5	6.0	15	200	20	1.0	0.5	$\pm$ 3.0	$\pm$ 18	Quad MC1741	L, P/646
MC34004	200 pA	10	10	100 pA	25	4.0	13	$\pm$ 5.0	$\pm$ 18	JFET Input	L, P/646
MC34004B	200 pA	5.0	10	100 pA	50	4.0	13	$\pm$ 5.0	$\pm$ 18	JFET Input	L, P/646
MC34074	0.5	5.0	10	75	25	4.5	10	+3.0	+44	High Performance,	L, P/646
MC34074A	500 nA	3.0	10	50	50	4.5	10	+3.0	+44	Single Supply	L, P/646
MC34084	200 pA	12	10	100 pA	25	8.0	30	$\pm$ 5.0	$\pm$ 22	High Speed JFET Input	P/646
MC34085	200 pA	12	10	100 pA	25	16	55	$\pm$ 5.0	$\pm$ 22	Decompensated	P/646
MC34184	0.1 nA	10	10	0.05	25	4.0	10	$\pm$ 2.5	$\pm$ 18	Low Power JFET Input	P/646
TL064AC	200 pA	6.0	10	100 pA	4.0	2.0	6.0	$\pm$ 2.5	$\pm$ 18	Low Power JFET Input	N/646
TL064C	200 pA	15	10	200 pA	4.0	2.0	6.0	$\pm$ 2.5	$\pm$ 18	Low Power JFET Input	N/646

**Table 3. Quad Operational Amplifiers**

Device	I <sub>B</sub> (μA) Max	V <sub>IO</sub> (mV) Max	TC <sub>VIO</sub> (μV/°C) Typ	I <sub>IO</sub> (nA) Max	A <sub>vol</sub> (V/mV) Min	BW (A <sub>v</sub> = 1) (MHz) Typ	SR (A <sub>v</sub> = 1) (V/μs) Typ	Supply Voltage (V)		Description	Suffix/ Package
								Min	Max		
TL074AC	200 pA	6.0	10	50 pA	50	4.0	13	±5.0	±18	Low Noise JFET Input	J/632, N/646
TL074C	200 pA	10	10	50 pA	25	4.0	13	±5.0	±18	Low Noise JFET Input	J/632, N/646
TL084AC	200 pA	6.0	10	100 pA	50	4.0	13	±5.0	±18	JFET Input	J/632, N/646
TL084C	400 pA	15	10	200 pA	25	4.0	13	±5.0	±18	JFET Input	J/632, N/646
<b>Industrial Temperature Range (-25°C to +85°C)</b>											
LM224	0.15	5.0	7.0	30	50	1.0	0.6	±1.5 +3.0	±16 +32	Split Supplies Single Supply	J/632, N/646
LM248	0.2	6.0	—	50	25	1.0	0.5	±3.0	±18	Quad MC1741	J/632, N/646
<b>Automotive Temperature Range (-40°C to +85°C)</b>											
MC3301/ LM2900	0.3	—	—	—	1.0	4.0	0.6	±2.0 +4.0	±15 +28	Norton Input	P/646 N/646
LM2902	0.5	10	—	50	—	1.0	0.6	±1.5 +3.0	±13 +26	Differential Low Power	J/632, N/646
MC3303	0.5	8.0	10	75	20	1.0	0.6	±1.5 +3.0	±18 +36	Differential General Purpose	P/646
MC33074	0.5	4.5	10	75	25	4.5	10	±3.0	+44	High Performance, Single Supply	L, P/646
MC33074A	500 nA	3.0	10	50	50	4.5	10	+3.0	+44	High Performance	L, P/646
MC33079	750 nA	2.5	2.0	150	31.6	9.0	7.0	±5.0	±18	Low Noise	N/646
MC33174	0.1	4.5	10	20	50	1.8	2.1	+3.0	+44	Low Power Single Supply	P/646
MC33179	0.5	3.0	2.0	50	50	5.0	2.0	±2.0	±18	High Output Current	P/646
MC33184	0.1 nA	10	10	0.05	25	4.0	10	±2.5	±18	Low Power JFET Input	P/646
MC33274	650 nA	1.0	0.56	25 nA	31.6	5.5	11.5	±1.5	±18	High Performance	P/646
MC33284	100 pA	2.0	5.0	50 pA	50	30	12	±2.5	±18	Low Input Offset JFET	P/646
TL064V	200 pA	9.0	10	100 pA	4.0	2.0	6.0	±2.5	±18	Low Power JFET Input	N/646
<b>Extended Automotive Temperature Range (-40°C to +105°C)</b>											
MC33204	200 nA	6.0	2.0	50	50	2.2	1.0	+1.8	+12	Low V Rail-to-Rail™	P/646, D/751A
<b>Telecommunications Temperature Range (-40°C to +85°C)</b>											
MC143403	1.0 nA	30	—	200 pA	45 dB	0.8	1.5	4.75	12.6	CMOS Low Power, Drives Low-Impedance Loads	L, P/646
MC143404	1.0 nA	30	—	200 pA	60 dB	0.8	1.0	4.75	12.6	CMOS Very Low Power	L, P/646
<b>Military Temperature Range (-55°C to +125°C)</b>											
LM124	0.15	5.0	7.0	30	50	1.0	0.6	±1.5 +3.0	±16 +32	Low Power Consumption	J/632, N/646
MC3503	0.5	5.0	7.0	50	50	1.0	0.6	±1.5 +3.0	±18 +36	General Purpose, Low Power	L, P/646
MC4741	0.5	5.0	15	200	50	1.0	0.5	±3.0	±22	Quad MC1741	L
MC35004	100 pA	10	10	100 pA	25	4.0	13	±5.0	±22	JFET Input	L
MC35004B	100 pA	5.0	10	50 pA	50	4.0	13	±5.0	±22	JFET Input	L
MC35074	0.5	5.0	10	75	25	4.5	10	+3.0	+44	High Performance, Single Supply	L
MC35074A	500 nA	3.0	10	50	50	4.5	10	+3.0	+44	High Performance	L
MC35084	200 pA	12	10	100 pA	25	8.0	30	±5.0	±22	High Speed JFET Input	L
MC35085	200 pA	12	10	100 pA	25	16	55	±5.0	±22	Decompensated	L
MC35174	0.1	4.5	10	20	50	1.8	2.1	+3.0	+44	Low Power, Single Supply	L
TL064M	200 pA	9.0	10	100 pA	4.0	2.0	6.0	±2.5	±18	Low Power JFET Input	J/632
TL074M	200 pA	9.0	10	50 pA	35	4.0	13	±5.0	±18	Low Noise JFET Input	J/632
TL084M	200 pA	9.0	10	100 pA	25	4.0	13	±5.0	±18	JFET Input	J/632

4

## High Frequency Amplifiers

A variety of high frequency circuits with features ranging from low cost simplicity to multi-function versatility marks Motorola's line of integrated amplifiers. Devices described here are intended for industrial and communications applications. For devices especially dedicated to consumer products, i.e., TV and entertainment radio. (See the Consumer Electronics Circuits section.)

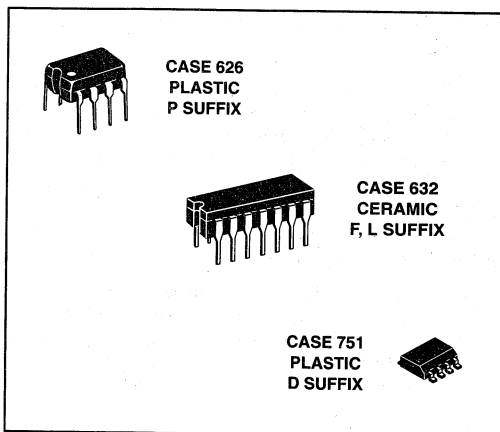

## AGC Amplifiers

### MC1490/MC1350

#### Family Wideband General Purpose Amplifiers

The MC1490 and MC1350 family are basic building blocks — AGC (Automatic Gain Controlled) RF/Video Amplifiers. These parts are recommended for applications up through 70 MHz. The best high frequency performance may be obtained by using the physically smaller SOIC version (shorter leads) — MC1350D. There are currently no other RF ICs like these, because other manufacturers have dropped their copies. Applications include variable gain

video and instrumentation amplifiers, IF (Intermediate Frequency) amplifiers for radio and TV receivers, and transmitter power output control. Many uses will be found in medical instrumentation, remote monitoring, video/graphics processing, and a variety of communications equipment. The family of parts using the same basic die (identical circuit with slightly different test parameters) is listed in the following table.

4

### MC1445/MC1545

#### Gated 2-Channel Input

Differential input and output amplifier with gated 2-channel input provides for a wide variety of switching purposes. Typical 50 MHz bandwidth makes it suitable for high frequency

applications such as video switching, FSK circuits, multiplexers, etc. Gating circuit is useful for AGC control.

Table 4. High-Frequency Amplifier Specifications

Operating Temperature Range			A <sub>v</sub> (dB)	Bandwidth @ MHz	V <sub>CC</sub> /V <sub>EE</sub> (V <sub>dc</sub> )		Suffix/Package
-55° to +125°C	-40° to +85°C	0° to +70°C			Typ	Min	
—	—	MC1350	50 50	45 45	+ 6.0	+ 18	P/626, D/751
—	MC1490	—	50 45 35	10 60 100	+ 6.0	+ 18	P/626
MC1545	—	MC1445	19	50	± 4.0	± 12	L/632

# Miscellaneous Amplifiers

Motorola provides several Bipolar and CMOS special purpose amplifiers which fill specific needs. These devices range from low power CMOS programmable amplifiers and comparators to variable-gain bipolar power amplifiers.

## MC3405/MC3505 Dual Operational Amplifier and Dual Voltage Comparator

This device contains two Differential Input Operational Amplifiers and two Comparators; each set capable of single supply operation. This operational amplifier-comparator circuit will find its applications as a general purpose product for automotive circuits and as an industrial "building block."

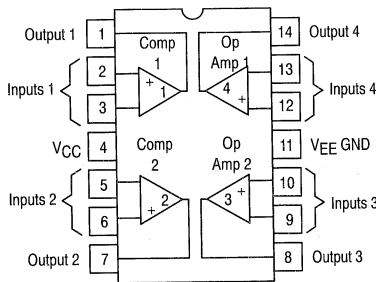

4

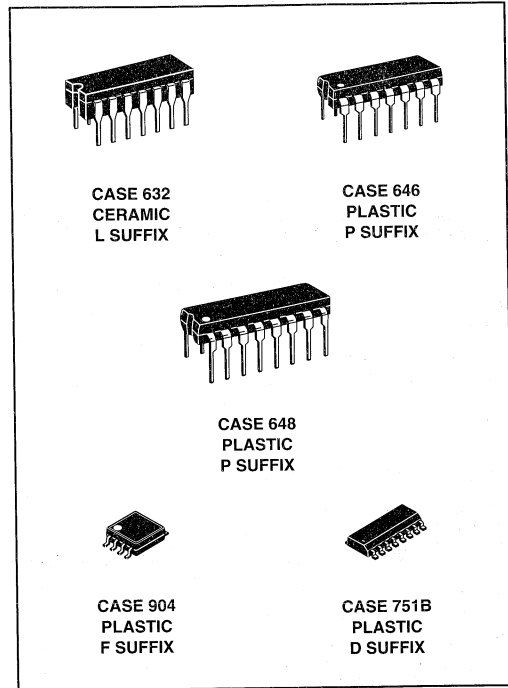

Table 5. Bipolar

Device	$I_{IB}$ ( $\mu A$ ) Max	$V_{IO}$ (mV) Max	$I_{IO}$ (nA) Max	$A_{vol}$ (V/mV) Min	Response ( $\mu s$ ) Typ	Supply Voltage		Suffix/ Package
						Single	Dual	
MC3405	0.5	10	50	20	1.3	3.0 to 36	$\pm 1.5$ to $\pm 18$	L/632, P/646
MC3505	0.5	5.0	50	20	1.3	3.0 to 36	$\pm 1.5$ to $\pm 18$	L/632

## MC14573 Quad Programmable Operational Amplifier

## MC14576B/MC14577B Dual Video Amplifiers

## MC14575 Dual Programmable Operational Amplifier and Dual Programmable Comparator

Table 6. CMOS

Function	Quantity Per Package	Single Supply Voltage Range	Dual Supply Voltage Range	Frequency Range	Device	Suffix/ Package
Operational Amplifiers	4	3.0 to 15 V	$\pm 1.5$ to $\pm 7.5$ V	DC to 1.0 MHz	MC14573	D/751B, P/648
Video Amplifiers	2	5 to 12 V(1)	$\pm 2.5$ to $\pm 6$ V(2)	Up to 10 MHz	MC14576B MC14577B	P/626, F/904
Operational Amplifiers and Comparators	2 and 2	3 to 15 V	$\pm 1.5$ to $\pm 7.5$ V	DC to 1.0 MHz	MC14575	D/751B, P/648

(1) 5.0 to 10 V for surface mount package.  
(2)  $\pm 2.5$  to  $\pm 5$  V for surface mount package.

# Comparators

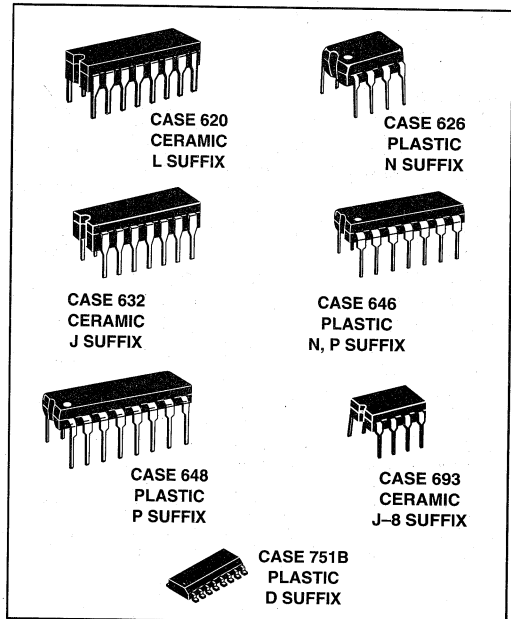

4

Table 7. Single

Device	I <sub>B</sub> ( $\mu$ A) Max	V <sub>IO</sub> (mV) Max	I <sub>IO</sub> ( $\mu$ A) Max	A <sub>V</sub> (V/V) Typ	I <sub>IO</sub> (mA) Min	Response Time (ns)	Supply Voltage (V)	Description	Temperature Range (°C)	Suffix/ Package
<b>Bipolar</b>										
LM111	0.1	3.0	0.01	200 k	8.0	200	+ 15, - 15	With strobe, will operate from single supply	- 55 to + 125	J-8
LM211	0.1	3.0	0.01	200 k	8.0	200	+ 15, - 15		- 25 to + 85	J-8
LM311	0.25	7.5	0.05	200 k	8.0	200	+ 15, - 15		0 to + 70	N/626, J-8
<b>CMOS</b>										
MC14578	1.0 $\mu$ A	50	—	—	1.1	—	3.5 to 14	Requires only 10 $\mu$ A from single-ended supply	- 30 to + 70	P/648 D/751B

Table 8. Dual

Device	I <sub>B</sub> ( $\mu$ A) Max	V <sub>IO</sub> (mV) Max	I <sub>IO</sub> ( $\mu$ A) Max	A <sub>V</sub> (V/V) Typ	I <sub>IO</sub> (mA) Min	Response Time (ns)	Supply Voltage (V)	Description	Temperature Range (°C)	Suffix/ Package
<b>Bipolar</b>										
LM393	0.25	5.0	0.05	200 k	6.0	1300	$\pm 1.5$ to $\pm 18$	Designed for single or split supply operation, input common mode includes ground (negative supply)	0 to + 70	N/626
LM393A	0.25	2.0	0.05	200 k	6.0	1300	or 3.0 to 36		0 to + 70	N/626
LM2903	0.25	7.0	0.05	200 k	6.0	1500			- 40 to + 85	N/626
MC3405	0.5	10	0.05	200 k	6.0	1300	$\pm 1.5$ to $\pm 7.5$	This device contains 2 op amps and 2 comparators in a single package	0 to + 70	L, P/646 L
MC3505	0.5	5.0	0.05	200 k	6.0	1300	or 3.0 to 15		- 55 to + 125	
<b>CMOS</b>										
MC14575	0.001	30	0.0001	2 k	3.0	1000	$\pm 1.5$ to $\pm 7.5$ or 3.0 to 15	This device contains 2 op amps and 2 comparators in a single package	- 40 to + 85	P/648 D/751B



## Comparators (continued)

Table 9. Quad

Device	I <sub>B</sub> ( $\mu$ A) Max	V <sub>IO</sub> (mV) Max	I <sub>O</sub> ( $\mu$ A) Max	A <sub>v</sub> (V/V) Typ	I <sub>O</sub> (mA) Min	Response Time (ns)	Supply Voltage (V)	Description	Temperature Range (°C)	Suffix/ Package
<b>Bipolar</b>										
LM139	0.1	5.0	0.025	200 k	6.0	1300	$\pm 1.5$ to $\pm 18$	Designed for single or split supply operation, input common mode includes ground (negative supply)	-55 to +125	J
LM139A	0.1	2.0	0.025	200 k	6.0	1300	or		-55 to +125	J
LM239	0.25	5.0	0.05	200 k	6.0	1300	3.0 to 36		-25 to +85	J, N/646
LM239A	0.25	2.0	0.05	200 k	6.0	1300			-25 to +85	J, N/646
LM339	0.25	5.0	0.05	200 k	6.0	1300			0 to +70	J, N/646
LM339A	0.25	2.0	0.05	200 k	6.0	1300			0 to +70	J, N/646
LM2901	0.25	7.0	0.05	100 k	6.0	1300			-40 to +85	N/646
MC3302	0.5	20	0.5	30 k	6.0	1300			-40 to +85	P/646
MC3430	40	6.0	1.0 Typ	1.2 k	16	33	+5.0, -5.0		High speed comparator/ sense-amplifier	0 to +70
MC3431	40	10	1.0 Typ	1.2 k	16	33	+5.0, -5.0	0 to +70		L, P/648
MC3432	40	6.0	1.0 Typ	1.2 k	16	40	+5.0, -5.0	0 to +70		L, P/648
MC3433	40	10	1.0 Typ	1.2 k	16	40	+5.0, -5.0	0 to +70		L, P/648
<b>CMOS</b>										
MC14574	0.001	30	0.0001	2.0 k	3.0	1000	$\pm 1.5$ to $\pm 7.5$ or 3.0 to 15	Externally programmable power dissipation with 1 or 2 resistors	-40 to +85	P/648 D/751B

4

# Power Supply Circuits

---

## In Brief . . .

In most electronic systems some form of voltage regulation is required. In the past, the task of voltage regulator design was tediously accomplished with discrete devices, and the results were quite often complex and costly. Today, with bipolar monolithic regulators, this task has been significantly simplified. The designer now has a wide choice of fixed, low  $V_{diff}$ , adjustable, and tracking series-type voltage regulators. These devices incorporate many built-in protection features, making them virtually immune to the catastrophic failures encountered in older discrete designs.

The Switching Power Supply continues to increase in popularity and is one of the fastest growing markets in the world of power conversion. They offer the designer several important advantages over Linear series-pass regulators. These advantages include significant advancements in the areas of size and weight reduction, improved efficiency, and the ability to perform voltage step-up, step-down, and voltage-inverting functions. Motorola offers a diverse portfolio of full featured switching regulator control circuits which meet the needs of today's modern compact electronic equipment.

Power supplies, MPU/MCU-based systems, industrial controls, computer systems and many other product applications are requiring power supervisory functions which monitor voltages to ensure proper system operation. Motorola offers a wide range of power supervisory circuits that fulfill these needs in a cost effective and efficient manner. MOSFET drivers are also provided to enhance the drive capabilities of first generation switching regulators or systems designed with CMOS/TTL logic devices. These drivers can also be used in DC-to-DC converters, motor controllers or virtually any other application requiring high speed operation of power MOSFETs.

	Page
Linear Voltage Regulators	
Fixed Output . . . . .	4.2-2
Adjustable Output . . . . .	4.2-5
Special Regulators . . . . .	4.2-6
Switching Regulator Control Circuits	
Single-Ended . . . . .	4.2-7
Single-Ended with On-Chip Power Switch . . . . .	4.2-9
Double-Ended . . . . .	4.2-10
Special Switching Regulator Controllers	
Dual Channel Current Mode . . . . .	4.2-11
Universal Microprocessor . . . . .	4.2-11
Power Factor Controllers . . . . .	4.2-12
Power Supervisory Circuits	
Overvoltage Crowbar Sensing . . . . .	4.2-14
Over/Undervoltage Protection . . . . .	4.2-14
Undervoltage Sense . . . . .	4.2-15
Microprocessor Voltage Regulator and Supervisory . . . . .	4.2-16
Universal Voltage Monitor . . . . .	4.2-16
MOSFET Drivers . . . . .	4.2-17



# Linear Voltage Regulators

## Fixed Output

These low cost monolithic circuits provide positive and/or negative regulation at currents from 100 mA to 3.0 A. They are ideal for on-card regulation employing current limiting and thermal shutdown. Low  $V_{diff}$  devices are offered for battery powered systems.

Although designed primarily as fixed voltage regulators, these devices can be used with external components to obtain adjustable voltages and currents.

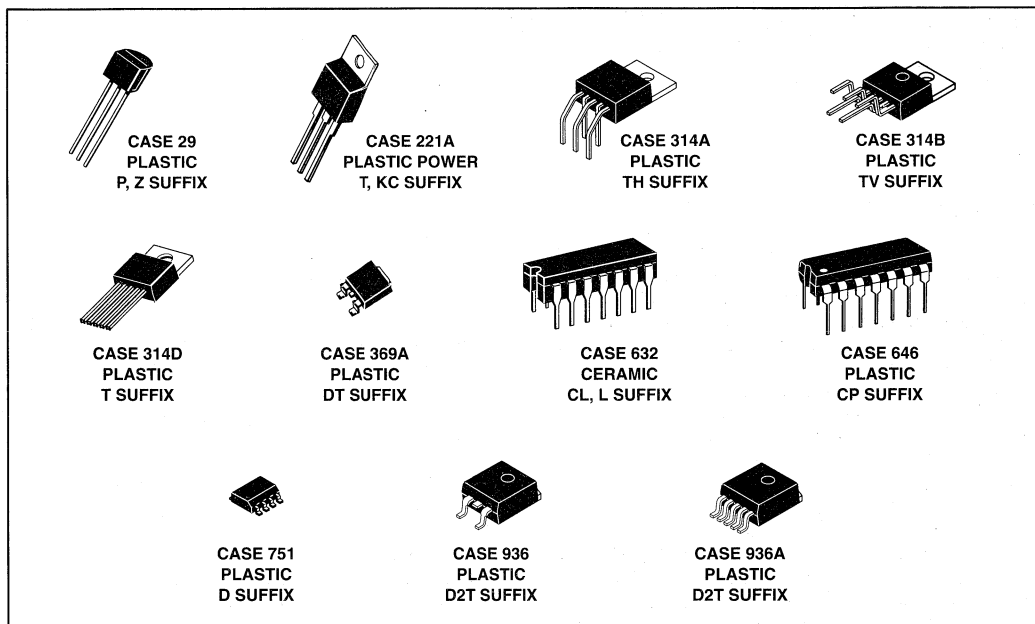

4

Table 10. Fixed-Voltage, 3-Terminal Regulators for Positive or Negative Polarity Power Supplies

$V_{out}$ (V)	Tol. <sup>(1)</sup> (V)	$I_O$ (mA) Max	Output Device		$V_{in}$ Min/Max	Regline (mV)	Regload (mV)	$\Delta V_O/\Delta T$ (mV/°C) Typ	Suffix/ Package
			Positive	Negative					
3.3	$\pm 0.03$	800	MC33269-3.3	—	4.3/20	0.3%	0.5%	—	D, DT
5.0	$\pm 0.5$	100	LM2931-5.0	—	5.6/40	30	50	1.0	Z, T
			MC78L05C	MC79L05C	6.7/30	200	60		P
	LM2931A-5.0		—	5.6/40	30	50	Z, T		
	MC78L05AC		MC79L05AC, AB	6.7/30	150	60	P, D		
	500	MC78M05C	MC79M05C, BC	7.0/35	100	100	DT, T		
$\pm 0.5$	750, 10	LM2935	—	5.6/26	30	50	T/314D, D2T, TV, TH		

(1) Output Voltage Tolerance for Worst Case.

(2)  $T_J = -40^\circ$  to  $+125^\circ\text{C}$ .

**Table 10. Fixed-Voltage, 3-Terminal Regulators for Positive or Negative Polarity Power Supplies (continued)**

V <sub>out</sub> (V)	Tol.(1) (V)	I <sub>O</sub> (mA) Max	Output Device		V <sub>in</sub> Min/Max	Regline (mV)	Regload (mV)	ΔV <sub>O</sub> /ΔT (mV/°C) Typ	Suffix/ Package	
			Positive	Negative						
5.0	± 0.25	1500	MCT7805B	—	8.0/35	100	100	1.0	T, D2T	
			MC7805B(2)	—						
			MCT7805C	—	7.0/35					
			MC7805C	MC7905C						
	± 0.2	MC7805AC	MC7905AC	7.5/35	10	0.6	T			
	± 0.25	LM340-5	—	7.0/35	50			50		
	± 0.2	LM340A-5	—		10			25		
	± 0.1	TL780-05C	—	—	5.0	—	—	0.06	KC	
	± 0.25	3000	MCT78T05C	—	7.3/35	25	30	0.1	T	
	± 0.2		MC78T05AC	—		10	25			
	± 0.25		LM323	—	7.5/20	25	100			
	± 0.2		LM323A	—		15	50			
± 0.05	800	MC33269-5	—	6.0/20	0.3%	0.5%	—	D, DT		
5.0	± 0.30	500	MC33267	—	6.0/28	50	50	—	T, 314, D2T, TV, TH	
5.2	± 0.26	1500	—	MC7905.2C	7.2/35	105	105	1.0	T	
6.0	± 0.3	500	MC78M06C	—	8.0/35	100	120	0.7	T, D2T	
		1500	MCT7806B	—	9.0/35					
			MC7806B(2)	—						
			MCT7806C	—	8.0/35					
	± 0.24	MC7806C	MC7906C	—	8.6/35	11	100	T		
	± 0.3	LM340-6	—	8.0/35	60	60				
8.0	± 0.8	100	MC78L08C	—	9.7/30	200	80	—	P	
			MC78L08AC	—		175				
	± 0.4	500	MC78M08C	—	10/35	100	160	1.0	DT, T	
			MC79M08	—						
		1500	MCT7808B	—	11.5/35	160				
			MC7808B(2)	—						
	MCT7808C		—	10.5/35						
	± 0.3	MC7808C	MC7908C	—	10.6/35	13	100	T		
	± 0.4	LM340-8	—	10.5/35	80	80				
	3000	MC78T08C	—	10.4/35	35	30	0.16			
	9.0	± 0.39	1500	MC7809C	—	11.5/35	50	50	1.0	T
	12	± 0.12	800	MC33269-12	—	13/20	0.3%	0.5%	—	D, DT
100			MC78L12C	MC79L12C	13.7/35	250	100	—	P, D	
		MC78L12AC	MC79L12AC, AB							

(1) Output Voltage Tolerance for Worst Case.  
 (2) T<sub>J</sub> = -40° to +125°C.

4

**Table 10. Fixed-Voltage, 3-Terminal Regulators for Positive or Negative Polarity Power Supplies (continued)**

V <sub>out</sub> (V)	Tol.(1) (V)	I <sub>O</sub> (mA) Max	Output Device		V <sub>in</sub> Min/Max	Regline (mV)	Regload (mV)	ΔV <sub>O</sub> /ΔT (mV/°C) Typ	Suffix/ Package
			Positive	Negative					
12	± 0.6	500	MC78M12C	MC79M12C, BC	14/35	100	240	1.0	DT, T
			MCT7812B	—	15.5/35	240		1.5	T, D2T
			MC7812B(2)	—	14.5/35				
			MCT7812C	—					
	MC7812C	MC7912C	14.5/35	18	100	32	0.15	KC	
	± 0.5	MC7812AC							—
	± 0.6	LM340-12							—
	± 0.5	LM340A-12							—
	± 0.24	TL780-12C							—
	± 0.6	3000							MC78T12C
± 0.5	MC78T12AC	—	18	25					
15	± 1.5	100	MC78L15C	MC79L15C	16.7/35	300	150	—	P, D
	± 0.75		MC78L15AC	MC79L15AC, AB					
	± 0.6	500	MC78M15C	MC79M15C, BC	17/35	100	300	1.0	DT, T
			MCT7815B	—	18.5/35	300	1.8	T, D2T	
		MC7815B(2)	—	17.5/35					
		MCT7815C	—						
		MC7815C	MC7915C	17.9/35	22	100	35	0.18	KC
		± 0.75	LM340-15						
	± 0.6	LM340A-15	—	22	35				
	± 0.3	TL780-15C	—	15	60				
	± 0.75	3000	MC78T15C	—	17.5/40	55	30	0.3	T
	± 0.6	MC78T15AC	—	22	25				
18	± 1.8	100	MC78L18C	MC79L18C	19.7/35	325	170	—	P
	± 0.9		MC78L18AC	MC79L18AC					
	± 0.7	500	MC78M18C	—	20/35	100	360	1.0	T
			MCT7818B(2)	—	22/35	360	2.3	T, D2T	
		MC7818C	MC7918C	21/35	31				100
		MC7818AC	—						
± 0.9	LM340-18	—	180	180					
20	± 1.0	500	MC78M20C	—	22/40	10	400	1.1	T
24	± 2.4	100	MC78L24C	MC79L24C	25.7/40	350	200	—	P
	± 1.2		MC78L24AC	MC79L24AC		300			
	500	MC78M24C	—	26/40	100	480	1.2	T	

(1) Output Voltage Tolerance for Worst Case.

(2) T<sub>J</sub> = -40° to +125°C.

4

**Table 10. Fixed-Voltage, 3-Terminal Regulators for Positive or Negative Polarity Power Supplies (continued)**

V <sub>out</sub> (V)	Tol.(1) (V)	I <sub>O</sub> (mA) Max	Output Device		V <sub>in</sub> Min/Max	Regline (mV)	Regload (mV)	ΔV <sub>O</sub> /ΔT (mV/°C) Typ	Suffix/Package	
			Positive	Negative						
24	± 1.2	1500	MCT7824B	—	28/40	480	480	3.0	T, D2T	
			MC7824B(2)	—						
			MCT7824C	—						27/40
			MC7824C	MC7924C						
	± 1.0		MC7824AC	—	27.3/40	36	100			T
	± 1.2		LM340-24	—		240	240			

(1) Output Voltage Tolerance for Worst Case.

(2) T<sub>J</sub> = -40° to +125°C.

## Adjustable Output

Motorola offers a broad line of adjustable output voltage regulators with a variety of output current capabilities. Adjustable voltage regulators provide users the capability of stocking a single integrated circuit offering a wide range of

output voltages for industrial and communications applications. The three-terminal devices require only two external resistors to set the output voltage.

**Table 11. Adjustable Positive Output Regulators**

I <sub>O</sub> (mA) Max	Device	V <sub>out</sub> (V)		V <sub>in</sub> (V)		V <sub>in</sub> - V <sub>out</sub> Differential (V) Min	P <sub>D</sub> (W) Max		Regulation % V <sub>out</sub> @ T <sub>A</sub> = 25°C Max		T <sub>C</sub> V <sub>out</sub> Typ (%/°C)	T <sub>J</sub> (°C) Max	Suffix/Package		
		Min	Max	Min	Max		T <sub>A</sub> = 25°C	T <sub>C</sub> = 25°C	Line	Load					
100	LM317L	1.2	37	5.0	40	3.0	Internally Limited	0.04	0.5	0.006	125	Z			
	LM2931C	3.0	24	3.16		0.6						0.15	1.0	—	T/314D, D2T, TV, TH
150	MC1723	2.0	37	9.5	40	3.0	1.25	—	0.1	0.3	0.003	150	CP		
							1.5	—				175	CL		
							—	—				0.002	L		
500	LM317M	1.2	—	5.0	—	—	Internally Limited	0.04	0.5	0.0056	125	T, DT			
800	MC33269-ADJ	1.25	19	2.25	20	1.0						0.3	—	150	D, DT
1500	LM317	1.2	37	5.0	40	3.0						0.04	0.006	125	T, D2T
3000	LM350	—	33	—	36	—						0.03	0.008	—	T

**Table 12. Adjustable Negative Output Regulators**

500	LM337M	-1.2	-37	5.0	4.0	3.0	Internally Limited	0.04	1.0	0.0048	125	T, DT
1500	LM337	—	—	—	—	—						T, D2T

4

# Special Regulators

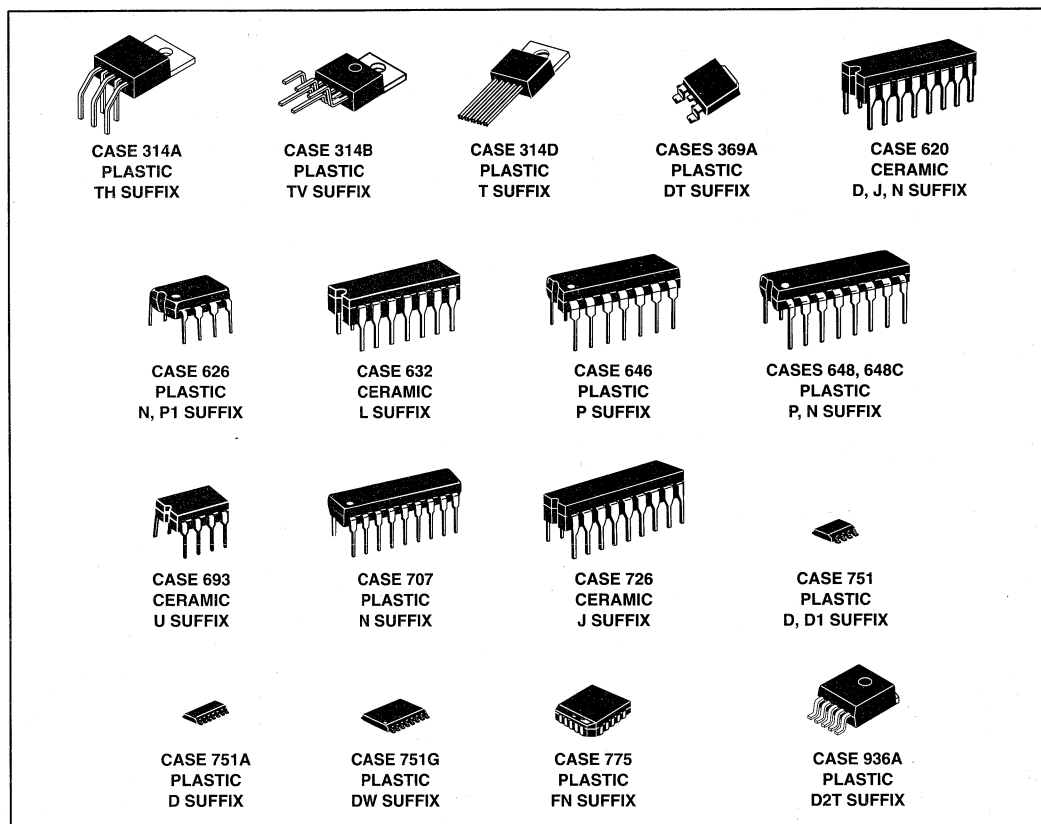

4

**Table 13. Microprocessor Voltage Regulator/Supervisory Circuit**

Device	V <sub>out</sub> (V)		I <sub>O</sub> (mA) Max	V <sub>in</sub> (V)		Reg <sub>line</sub> (mV) Max	Reg <sub>load</sub> (mV) Max	T <sub>A</sub> (°C)	Suffix/ Package
	Min	Max		Min	Max				
MC34160	4.75	5.25	100	7.0	40	40	50	0 to +70	P/648C
MC33160								-40 to +85	
MC33267	4.9	5.2	500	6.0	26	50	50	-40 to +105	T, TV

Note: A 5.0 V fixed output with monitoring functions required in microprocessor-based systems.

**Table 14. SCSI Regulator**

Device	V <sub>out</sub> (V)		I <sub>sink</sub> (mA)	V <sub>in</sub> (V)		Reg <sub>line</sub> (%)	Reg <sub>load</sub> (%)	T <sub>J</sub> (°C)	Suffix/ Package
	Min	Max		Min	Max				
MC34268	2.81	2.89	800	3.9	20	0.3	0.5	150	D/751, DT/751

# Switching Regulator Control Circuits

These devices contain the primary building blocks which are required to implement a variety of switching power supplies. The product offerings fall into three major categories consisting of single-ended and double-ended controllers, plus single-ended ICs with on-chip power switch transistors. These circuits operate in voltage, current or resonant modes

and are designed to drive many of the standard switching topologies. The single-ended configurations include buck, boost, flyback and forward converters. The double-ended devices control push-pull, half bridge and full bridge configurations.

**Table 15. Single-Ended Controllers**

$I_O$ (mA) Max	Minimum Operating Voltage Range (V)	Operating Mode	Reference (V)	Maximum Useful Oscillator Frequency (kHz)	Device	$T_A$ (°C)	Suffix/ Package
500 (Uncommitted Drive Output)	7.0 to 40	Voltage	$5.0 \pm 1.5\%$	200	MC34060A	0 to +70	D/751A
							L/632
						P/646	
					MC33060A	-40 to +85	D/751A
							P/646
1000 (Totem Pole MOSFET Drive Output)	4.2 to 12	Current	$1.25 \pm 2.0\%$	300	MC34129	0 to +70	D/751A
							P/646
			MC33129	-40 to +85	D/751A		
					P/646		
	11.5 to 30		$5.0 \pm 2.0\%$	500 (Guaranteed at 250)	UC3842A	0 to +70	D/751A
						N/626	
	11 to 30		$5.0 \pm 1.0\%$		UC2842A	-25 to +85	D/751A
						J/693	
						N/626	
	11.5 to 30		$5.0 \pm 2.0\%$		UC3842BV	-40 to +105	D/751A
						D1/751	
						N/626	
	8.2 to 30				UC3843A	0 to +70	D/751A
						N/626	
			$5.0 \pm 1.0\%$		UC2843A	-25 to +85	D/751A
						J/693	
			N/626				
	$5.0 \pm 2.0\%$	UC3843BV	-40 to +105		D/751A		
			D1/751				
			N/626				
11.5 to 30		500 (50% Duty Cycle Limit)	UC3844	0 to +70	D/751A		
				N/626			
11 to 30	$5.0 \pm 1.0\%$		UC2844	-25 to +85	D/751A		
				J/693			
			N/626				
8.2 to 30	$5.0 \pm 2.0\%$	UC3845	0 to +70	D/751A			
			N/626				

Note: These single-ended voltage and current mode controllers are designed for use in buck, boost, flyback, and forward converters. They are cost effective in applications that range from 0.1 to 200 W power output.

4



**Table 15. Single-Ended Controllers**

$I_O$ (mA) Max	Minimum Operating Voltage Range (V)	Operating Mode	Reference (V)	Maximum Useful Oscillator Frequency (kHz)	Device	$T_A$ (°C)	Suffix/ Package
1000 (Totem Pole MOSFET Drive Output)	8.2 to 30	Current	$5.0 \pm 1.0\%$	500 (50% Duty Cycle Limit)	UC2845	-25 to + 85	D/751A
							J/693
							N/626
	11.5 to 30		$5.0 \pm 2.0\%$	500 (Improved Oscillator Specifications with Frequency Guaranteed at 250 kHz)	UC3842B	0 to + 70	D/751A
							D1/751
							N/626
	11 to 30		$5.0 \pm 1.0\%$	UC2842B	-25 to + 85	D/751A	
						D1/751	
						N/626	
	8.2 to 30		$5.0 \pm 2.0\%$	UC3843B	0 to + 70	D/751A	
						D1/751	
						N/626	
			$5.0 \pm 1.0\%$	UC2843B	-25 to + 85	D/751A	
						D1/751	
						N/626	
	11.5 to 30		$5.0 \pm 2.0\%$	500 (50% Duty Cycle Limit)	UC3844B	0 to + 70	D/751A
							D1/751
							N/626
		UC3844BV	-40 to +105	D/751A			
				D1/751			
				N/626			
11 to 30	$5.0 \pm 1.0\%$	UC2844B	-25 to + 85	D/751A			
				D1/751			
				N/626			
8.2 to 30	$5.0 \pm 2.0\%$	UC3845B	0 to + 70	D/751A			
				D1/751			
				N/626			
		UC3845BV	-40 to +105	D/751A			
				D1/751			
				N/626			
$5.0 \pm 1.0\%$	UC2845B	-25 to + 85	D/751A				
			D1/751				
			N/626				
1000 Source 1500 Sink (Split Totem Pole BIPOLAR Drive Output)	11 to 18		$5.0 \pm 6.0\%$		MC44602		P2/648C

Note: These single-ended voltage and current mode controllers are designed for use in buck, boost, flyback, and forward converters. They are cost effective in applications that range from 0.1 to 200 W power output.

4

**Table 15. Single-Ended Controllers**

$I_O$ (mA) Max	Minimum Operating Voltage Range (V)	Operating Mode	Reference (V)	Maximum Useful Oscillator Frequency (kHz)	Device	$T_A$ (°C)	Suffix/ Package
2000 (Totem Pole MOSFET Drive Output)	9.2 to 30	Current	$5.1 \pm 1.0\%$	1000	MC34023	0 to +70	DW/751G
							FN/775
							P/648
					MC33023	-40 to +85	DW/751G
							FN/775
							P/648

Note: These single-ended voltage and current mode controllers are designed for use in buck, boost, flyback, and forward converters. They are cost effective in applications that range from 0.1 to 200 W power output.

**Table 16. Single-Ended Controllers with On-Chip Power Switch**

$I_O$ (mA) Max	Minimum Operating Voltage Range (V)	Operating Mode	Reference (V)	Maximum Useful Oscillator Frequency (kHz)	Device	$T_A$ (°C)	Suffix/ Package				
1500 (Uncommitted Power Switch)	2.5 to 40	Voltage	$1.25 \pm 5.2\%$ (2)	100	$\mu A78S40$	0 to +70	PC/648				
							DC/620				
							-40 to +85	PV/648			
							-55 to +125	DM/620			
							3.0 to 65	$1.25 \pm 2.0\%$	MC34063A	0 to +70	D/751
									P1/626		
	MC33063A		-40 to +85		D/751						
	P1/626										
	MC35063A		-55 to +125		U/693						
	3400 (Uncommitted Power Switch)		2.5 to 40		$1.25 \pm 2.0\%$ and $5.05 \pm 3.0\%$	72 $\pm$ 12% Internally Fixed			MC34165	0 to +70	P/648C
							MC33165	-40 to +85			
							MC34163	0 to +70			
MC33163		-40 to +85									
3400(3) (Dedicated Emitter Power Switch)		7.5 to 40		$5.05 \pm 2.0\%$			72 $\pm$ 12% Internally Fixed	MC34166	0 to +70	314A, 314B, 314D, 936A, T, D2T, TV, TH	
								MC33166	-40 to +85		
5500(4) (Dedicated Emitter Power Switch)	7.5 to 40	$5.05 \pm 2.0\%$	72 $\pm$ 12% Internally Fixed	MC34167	0 to +70						
				MC33167	-40 to +85						

(1) These monolithic power switching regulators contain all the active functions required to implement standard DC-to-DC converter configurations with a minimum number of external components.

(2) Tolerance applies over the specified operating temperature range.

(3) Guaranteed minimum, typically 4300 mA.

(4) Guaranteed minimum, typically 6500 mA.

4

**Table 17. Double-Ended Controller**

$I_O$ (mA) Max	Minimum Operating Voltage Range (V)	Operating Mode	Reference (V)	Maximum Useful Oscillator Frequency (kHz)	Device	$T_A$ (°C)	Suffix/ Package			
500 (Uncommitted Drive Outputs)	7.0 to 40	Voltage	$5.0 \pm 5.0\%$ (2)	200	TL494	0 to +70	CN/648			
							CJ/620			
						-25 to +85	IN/648			
			$5.0 \pm 1.5\%$	300	TL594	0 to +70	CN/648			
						-25 to +85	IN/648			
						-55 to +125	MJ/620			
$\pm 500$ (Totem Pole MOSFET Drive Outputs)	8.0 to 40		$5.1 \pm 2.0\%$	400	SG3525A	0 to +70	N/648			
							J/620			
					SG3527A		N/648			
							J/620			
$\pm 200$ (Totem Pole MOSFET Drive Outputs)			$5.0 \pm 2.0\%$		SG3526	0 to +125(2)	N/707			
							J/726			
$\pm 1500$ (Totem Pole MOSFET Drive Outputs)	9.6 to 20	Resonant (Zero Current Switch)	$5.1 \pm 2.0\%$	1000	MC34066	0 to +70	DW/751G			
							P/648			
					MC33066	-40 to +85	DW/751G			
				2000	MC34067	0 to +70	DW/751G			
							P/648			
					MC33067	-40 to +85	DW/751G			
							P/648			
2000 (Totem Pole MOSFET Drive Outputs)	9.2 to 30	Current	$5.1 \pm 1.0\%$	1000	MC34025	0 to +70	DW/751G			
							FN/775			
							P/648			
					MC33025	-40 to +85	DW/751G			
							FN/775			
							P/648			

(1) These double-ended voltage, current and resonant mode controllers are designed for use in push-pull, half-bridge, and full-bridge converters. They are cost effective in applications that range from 100 to 2000 watts power output.

(2) Tolerance applies over the specified operating temperature range.

(3) Junction Temperature Range.

4

# Special Switching Regulator Controllers

These high performance dual channel controllers are optimized for off-line AC-to-DC power supplies and DC-to-DC converters in the flyback topology. The newer -H and -L versions have undervoltage lockout voltages which

are optimized for off-line and lower voltage DC-to-DC converters respectively. Applications include desktop computers, peripherals, televisions, games, and various consumer appliances.

**Table 18. Dual Channel Current Mode Controllers**

$I_O$ (mA) Max	Minimum Operating Voltage Range (V)	Operating Mode	Reference (V)	Maximum Useful Oscillator Frequency (kHz)	Device	$T_A$ (°C)	Suffix/ Package
±1000 (Totem Pole MOSFET Drive Outputs)	11 to 15.5	Current	5.0 ± 2.0%	500	MC34065	0 to + 70	DW/751G
							P/648
					MC33065	-40 to + 85	DW/751G
							P/648
	11 to 20		MC34065		0 to + 70	DW-H/751G	
						P-H/648	
			MC33065		-40 to + 85	DW-H/751G	
						P-H/648	
	8.2 to 20	MC34065	0 to + 70	DW-L/751G			
				P-L/648			
		MC33065	-40 to + 85	DW-L/751G			
				P-L/648			

4

**Table 19. Universal Microprocessor Power Supply Controller**

Regulated Outputs	Output Current (mA)	$V_{CC}$ (V)		Device	$T_A$ (°C)	Reference (V)	Key Supervisory Features	Suffix/ Package
		Min	Max					
E <sup>2</sup> PROM Programmable Output: 24 V (Write Mode) 5.0 V (Read Mode)	150 peak	6.0	35	TCF5600	-40 to + 85	2.5 ± 3.2%	MPU Reset and Watchdog Circuit	707
Fixed Linear Output: 5.0 V	10 to external buffer transistor			TCA5600				

Note: A versatile power supply control circuit for microprocessor-based systems, this device is mainly intended for automotive applications and battery powered instruments. The circuit provides a power-on Reset delay and a Watchdog feature for orderly microprocessor operation.

## Special Switching Regulator Controllers (continued)

Table 20. Power Factor Controllers

$I_O$ (mA) Max	Minimum Operating Voltage Range (V)	Operating Mode	Reference (V)	Features	Device	$T_A$ (°C)	Suffix/ Package
± 500 (Totem Pole MOSFET Drive Outputs)	9.0 to 30	Current	± 2.5	Undervoltage Lockout, Internal Start-Up Timer	MC34261	0 to + 70	D/751
							P/626
					MC33261	- 40 to + 85	D/751
							P/626
				Overvoltage Comparator, Undervoltage Lockout, Internal Start-Up Timer	MC34262	0 to + 70	D/751
							P/626
				MC33262	- 40 to +105	D/751	
						P/626	

# 4

## Power Factor Controllers

### MC34261D, P

$T_A = 0^\circ$  to  $+70^\circ\text{C}$ , Case 751, 626

### MC33261D, P

$T_A = -40^\circ$  to  $+85^\circ\text{C}$ , Case 751, 626

The MC33261, MC34261 series are power factor controller circuits specifically designed for use as a preconverter in electronic ballast and in off-line converter applications. These integrated circuits feature an internal start-up timer, a one quadrant multiplier for near unit power factor, zero current detector to ensure critical conduction operation, high gain error amplifier, trimmed internal bandgap reference, current sensing comparator and a totem pole output ideally suited for driving a power MOSFET or an IGBT.

Also included are protective features consisting of input undervoltage lockout with hysteresis, cycle-by-cycle current limiting and a latch for single pulse metering.

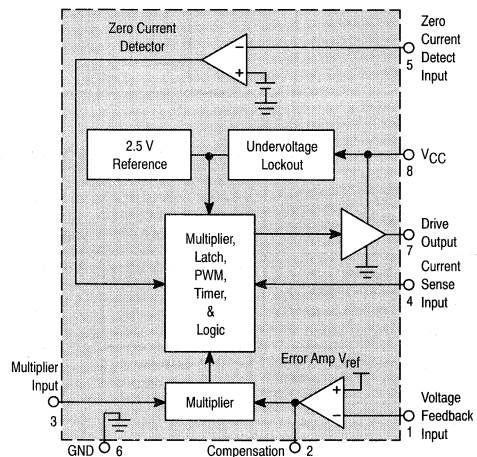

## Power Factor Controllers (continued)

### MC34262D, P

$T_A = 0^\circ$  to  $+85^\circ\text{C}$ , Case 751, 626

### MC33262D, P

$T_A = -40^\circ$  to  $+105^\circ\text{C}$ , Case 751, 626

The MC34262, MC33262 series are active power factor controllers specifically designed for use as a preconverter in electronic ballast and in off-line power converter applications. These integrated circuits feature an internal start-up timer for stand alone applications, a one quadrant multiplier for near unity power factor, zero current detector to ensure critical conduction operation, transconductance error amplifier, quickstart circuit for enhanced start-up, trimmed internal bandgap reference, current sensing comparator, and a totem pole output ideally suited for driving a power MOSFET.

Also included are protective features consisting of an overvoltage comparator to eliminate runaway output voltage due to load removal, input undervoltage lockout with hysteresis, cycle-by-cycle current limiting, multiplier output clamp that limits maximum peak switch current, an RS latch for single pulse metering, and a drive output high state clamp for MOSFET gate protection. These devices are available in dual-in-line and surface mount plastic packages.

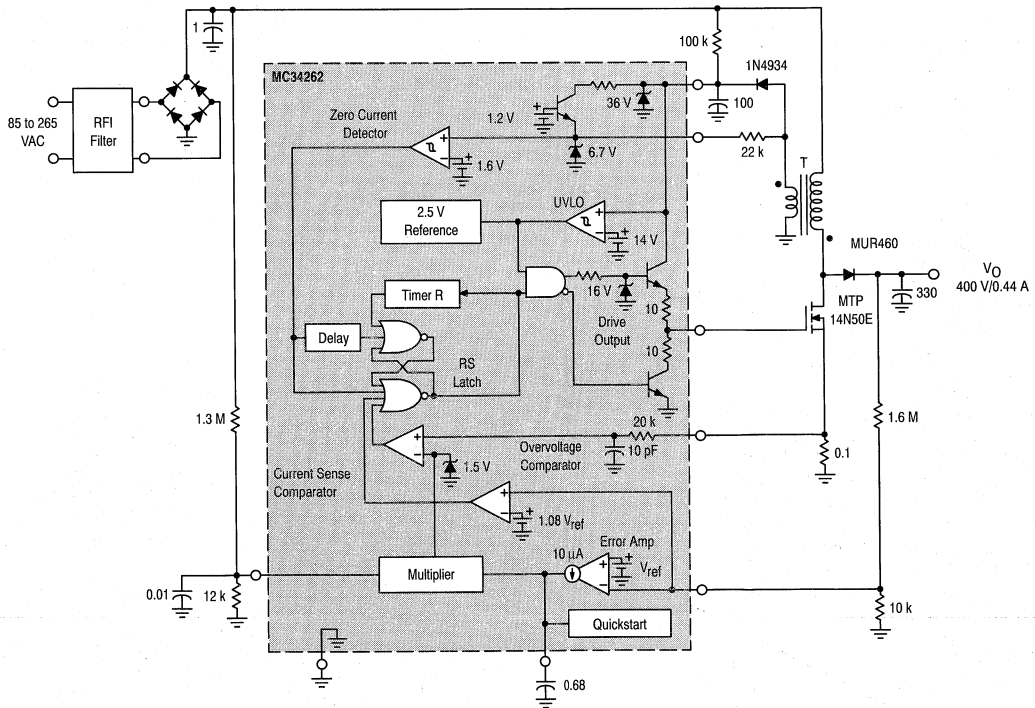

4

# Power Supervisory Circuits

A variety of Power Supervisory Circuits are offered. Overvoltage sensing circuits which drive "Crowbar" SCRs are provided in several configurations from a low cost three-terminal version to 8-pin devices which provide

pin-programmable trip voltages or additional features, such as an indicator output drive and remote activation capability. An over/undervoltage protection circuit is also offered.

## Overvoltage Crowbar Sensing Circuit

**MC3523U**

$T_A = -55^\circ$  to  $+125^\circ\text{C}$ , Case 693

**MC3423P1, U**

$T_A = 0^\circ$  to  $+70^\circ\text{C}$ , Case 626, 693

This device can protect sensitive circuitry from power supply transients or regulator failure when used with an external "Crowbar" SCR. The device senses voltage and compares it to an internal 2.6 V reference. Overvoltage trip is adjustable by means of an external resistive voltage divider. A minimum duration before trip is programmable with an external capacitor. Other features include a 300 mA high current output for driving the gate of a "Crowbar" SCR, an open-collector indicator output and remote activation capability.

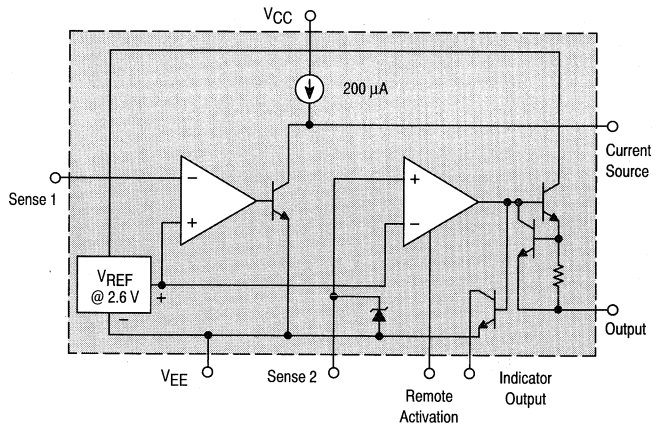

4

## Over/Undervoltage Protection Circuit

**MC3425P1**

$T_A = 0^\circ$  to  $+70^\circ\text{C}$ , Case 626

The MC3425 is a power supply supervisory circuit containing all the necessary functions required to monitor over and undervoltage fault conditions. This device features dedicated over and undervoltage sensing channels with independently programmable time delays. The overvoltage channel has a high current Drive Output for use in conjunction with an external SCR "Crowbar" for shutdown. The undervoltage channel input comparator has hysteresis which is externally programmable, and an open-collector output for fault indication.

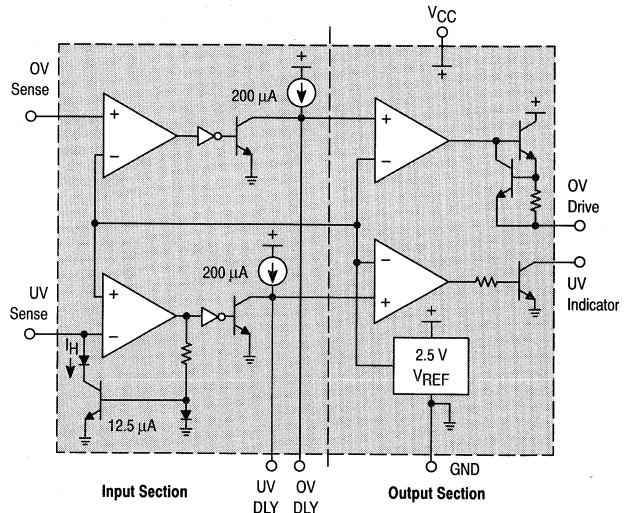

## Power Supervisory Circuits (continued)

### Undervoltage Sensing Circuit

#### MC34064P-5, D-5

$T_A = 0^\circ$  to  $+70^\circ\text{C}$ , Case 29, 751

#### MC33064P-5, D-5

$T_A = -40^\circ$  to  $+85^\circ\text{C}$ , Case 29, 751

#### MC34164P-3, P-5, D-3, D-5

$T_A = 0^\circ$  to  $+70^\circ\text{C}$ , Case 29, 751

#### MC33164P-3, P-5, D-3, D-5

$T_A = -40^\circ$  to  $+85^\circ\text{C}$ , Case 29, 751

The MC34064 and MC34164 are two families of undervoltage sensing circuits specifically designed for use as reset controllers in microprocessor-based systems. They offer the designer an economical solution for low voltage detection with a single external resistor. Both parts feature a trimmed bandgap reference, and a comparator with precise thresholds and built-in hysteresis to prevent erratic reset operation.

The two families of undervoltage sensing circuits taken together, cover the needs of the most commonly specified power supplies used in MCU/MPU systems. Key parameter specifications of the MC34164 family were chosen to complement the MC34064 series. The table summarizes critical parameters of both families. The MC34064 fulfills the needs of a  $5.0\text{ V} \pm 5\%$  system and features a tighter hysteresis specification. The MC34164 series covers  $5.0\text{ V} \pm 10\%$  and

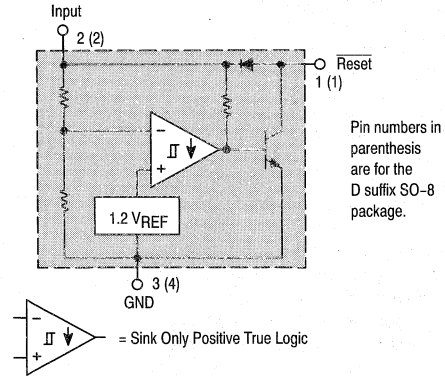

$3.0\text{ V} \pm 5\%$  power supplies with significantly lower power consumption, making them ideal for applications where extended battery life is required such as consumer products or hand held equipment.

Applications include direct monitoring of the  $5.0\text{ V}$  MPU/logic power supply used in appliance, automotive, consumer, and industrial equipment.

The MC34164 is specifically designed for battery powered applications where low bias current ( $1/25\text{th}$  of the MC34064's) is an important characteristic.

4

Table 21. Undervoltage Sense/Reset Controller Features

Device	Standard Power Supply Supported	Typical Threshold Voltage (V)	Typical Hysteresis Voltage (V)	Minimum Output Sink Current (mA)	Power Supply Input Voltage Range (V)	Maximum Quiescent Input Current $V_{in} = 5.0\text{ V}$	Suffix/Package
MC34064/MC33064	$5.0\text{ V} \pm 5\%$	4.6	0.02	10	1.0 to 10	$500\ \mu\text{A}$ @ $V_{in} = 5.0\text{ V}$	P-5/TO-92 D-5/SO-8
MC34164/MC33164	$5.0\text{ V} \pm 10\%$	4.3	0.09	7.0	1.0 to 12	$20\ \mu\text{A}$ @ $V_{in} = 5.0\text{ V}$	P-5/TO-92 D-5/SO-8
	$3.0\text{ V} \pm 5\%$	2.7	0.06	6.0	1.0 to 12	$15\ \mu\text{A}$ @ $V_{in} = 3.0\text{ V}$	P-3/TO-92 D-3/SO-8

Note: MC34X64 devices are specified to operate from  $0^\circ$  to  $+70^\circ\text{C}$ , and MC33X64 devices operate from  $-40^\circ$  to  $+85^\circ\text{C}$ .



## Power Supervisory Circuits (continued)

# Microprocessor Voltage Regulator and Supervisory Circuit

### MC34160P

$T_A = 0^\circ$  to  $+70^\circ\text{C}$ , Case 648C

### MC33160P

$T_A = -40^\circ$  to  $+85^\circ\text{C}$ , Case 648C

The MC34160 Series is a voltage regulator and supervisory circuit containing many of the necessary monitoring functions required in microprocessor based systems. It is specifically designed for appliance and industrial applications offering the designer a cost effective solution with minimal external components. These integrated circuits feature a 5.0 V, 100 mA regulator with short circuit current limiting, pinned out 2.6 V bandgap reference, low voltage reset comparator, power warning comparator with programmable hysteresis, and an uncommitted comparator ideally suited for microprocessor line synchronization.

Additional features include a chip disable input for low standby current, and internal thermal shutdown for over temperature protection.

These devices are contained in a 16 pin dual-in-line heat tab package for improved thermal conduction.

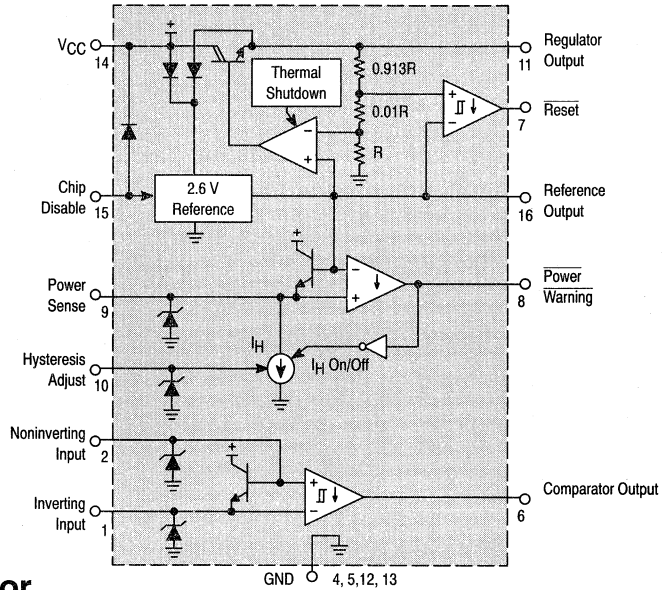

## Universal Voltage Monitor

### MC34161P, D

$T_A = 0^\circ$  to  $+70^\circ\text{C}$ , Case 626, 751

### MC33161P, D

$T_A = -40^\circ$  to  $+85^\circ\text{C}$ , Case 626, 751

The MC34161 series of Universal Voltage Monitor ICs are capable of being used in a wide variety of voltage sensing applications. These versatile devices offer an economical solution for implementing over, under and window detection of both positive and/or negative voltages.

The circuit consists of two comparator channels each with hysteresis, a pinned out 2.54 V reference, two open collector outputs capable of sinking in excess of 10 mA, and a "Mode Select" input for programming the functions of the two comparator channels. The devices are fully functional from 2.0 V to 40 V for positive voltage sensing and from 4.0 V to 40 V for negative voltage sensing.

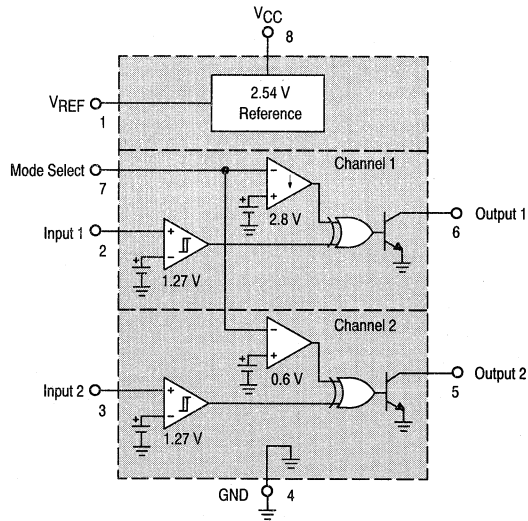

# MOSFET Drivers

## High Speed Dual Drivers

### Inverting

#### MC34151P, D

$T_A = 0^\circ$  to  $+70^\circ\text{C}$ , Case 626, 751

#### MC33151P, D

$T_A = -40^\circ$  to  $+85^\circ\text{C}$ , Case 626, 751

### Noninverting

#### MC34152P, D

$T_A = 0^\circ$  to  $+70^\circ\text{C}$ , Case 626, 751

#### MC33152P, D

$T_A = -40^\circ$  to  $+85^\circ\text{C}$ , Case 626, 751

These two series of High Speed Dual MOSFET Driver ICs are specifically designed for applications requiring low current digital circuitry to drive large capacitive loads at high slew rates. Both series feature a unique undervoltage lockout function which puts the outputs in a defined low state in an undervoltage condition. In addition, the low on-state resistance of these bipolar drivers allows significantly higher output currents at lower supply voltages than with competing drivers using CMOS technology.

The MC34151 series is pin-compatible with the MMH0026 and DS0026 dual MOS clock drivers, and can be used as drop-in replacements to upgrade system performance. The MC34152 noninverting series is a mirror image of the inverting MC34151 series.

These devices can enhance the drive capabilities of first generation switching regulators or systems designed with CMOS/TTL logic devices. They can be used in DC-to-DC converters, motor controllers, capacitor charge pump converters, or virtually any other application requiring high speed operation of power MOSFETs.

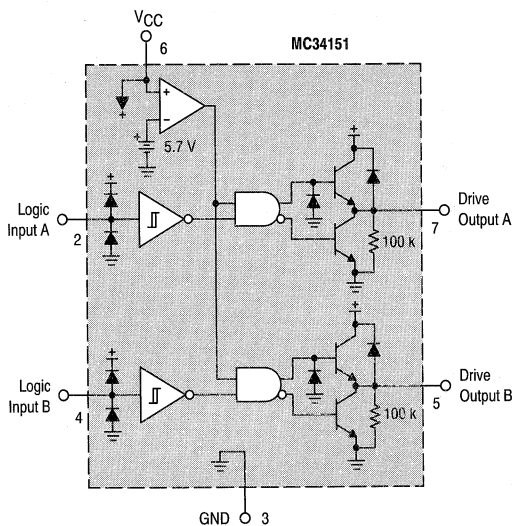

4

**4**

# Power/Motor Control Circuits

---

## In Brief . . .

With the expansion of electronics into more and more mechanical systems there comes an increasing demand for simple but intelligent circuits that can blend these two technologies. In the past, the task of power/motor control was once accomplished with discrete devices. But today this task is being performed by bipolar IC technology due to cost, size, and reliability constraints. Motorola offers integrated circuits designed to anticipate the requirements for both simple and sophisticated control systems, while providing cost effective solutions to meet the needs of the applications.

	<b>Page</b>
Power Controllers . . . . .	4.3-2
Zero Voltage Switches . . . . .	4.3-2
Zero Voltage Controller . . . . .	4.3-3
High-Side Driver Switch . . . . .	4.3-3
Motor Controllers . . . . .	4.3-4
Brushless DC Motor Controllers . . . . .	4.3-4
DC Servo Motor Controller/Driver . . . . .	4.3-7
Closed-Loop Brushless Motor Adapter . . . . .	4.3-8
Stepper Motor Driver . . . . .	4.3-9
Universal Motor Speed Controllers . . . . .	4.3-10
Triac Phase Angle -Controller . . . . .	4.3-11

# Power Controllers

An assortment of battery and AC line-operated control ICs for specific applications are shown. They are designed to enhance system performance and reduce complexity in a wide variety of control applications.

## Zero Voltage Switches

CA3079/CA3059

$T_A = -40^\circ$  to  $+85^\circ\text{C}$ , Case 646

These devices are designed for thyristor control in a variety of AC power switching applications for AC input voltages of 24 V, 120 V, 208/230 V, and 227 V @ 50/60 Hz.

- **Limiters—Power Supply** — Allows operation directly from an AC line.
- **Differential On/Off Sensing Amplifier** — Tests for condition of external sensors or input command signals. Proportional control capability or hysteresis may be implemented.
- **Zero-Crossing Detector** — Synchronizes the output pulses to the zero voltage point of the AC cycle. Eliminates RFI when used with resistive loads.
- **Triac Drive** — Supplies high-current pulses to the external power controlling thyristor.
- **Protection Circuit** (CA3059 only) — A built-in circuit may be actuated, if the sensor opens or shorts, to remove the drive circuit from the external triac.
- **Inhibit Capability** (CA3059 only) — Thyristor firing may be inhibited by the action of an internal diode gate.
- **High Power DC Comparator Operation** (CA3059 only) — Operation in this mode is accomplished by connecting Pin 7 to Pin 12 (thus overriding the action of the zero-crossing detector).

4

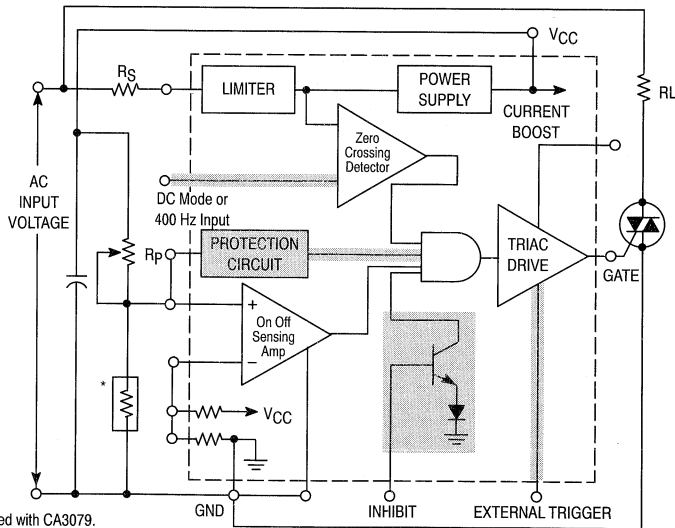
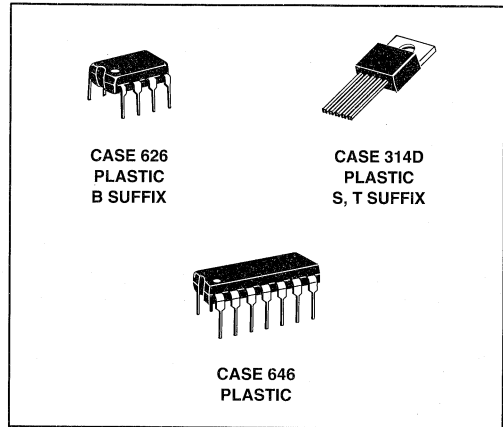

\*NTC Sensor

NOTE: Shaded Area Not Included with CA3079.

**Power Controllers (continued)**

**Zero Voltage Controller**

**UAA1016B**

$T_A = -20^\circ$  to  $+100^\circ\text{C}$ , Case 626

This device is designed to drive triacs with the Zero Voltage technique which allows RFI free power regulation of resistive loads. They provide the following features:

- Proportional Temperature Control Over an Adjustable Band
- Adjustable Burst Frequency (to Comply with Standards)
- Sensor Fail-Safe
- No DC Current Component Through the Main Line (to Comply with Standards)
- Negative Output Current Pulses (Triacs Quadrants 2 and 3)
- Direct AC Line Operation
- Low External Components Count

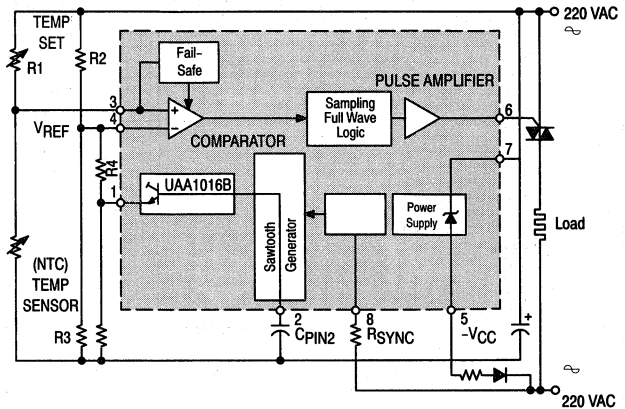

**High-Side Driver Switch**

**MC3399T**

$T_J = -40^\circ$  to  $+150^\circ\text{C}$ , Case 314D

The MC3399T is a High-Side Driver Switch that is designed to drive loads from the positive side of the power supply. The output is controlled by a TTL compatible Enable pin. In the ON state, the device exhibits very low saturation voltages for load currents in excess of 750 mA. The device also protects the load from positive or negative-going high voltage transients by becoming an open circuit and isolating the transient for its duration from the load.

The MC3399T is fabricated on a power BiMOS process which combines the best features of Bipolar and MOS technologies. The mixed technology provides higher gain PNP output devices and results in Power Integrated Circuits with reduced quiescent current.

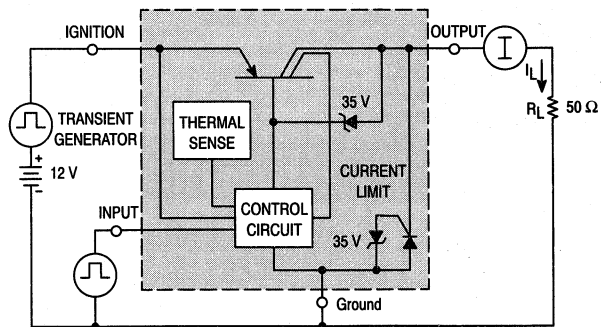

**4**

# Motor Controllers

This section contains integrated circuits designed for cost effective control of specific motor families. Included are

controllers for brushless, dc servo, stepper, and universal type motors.

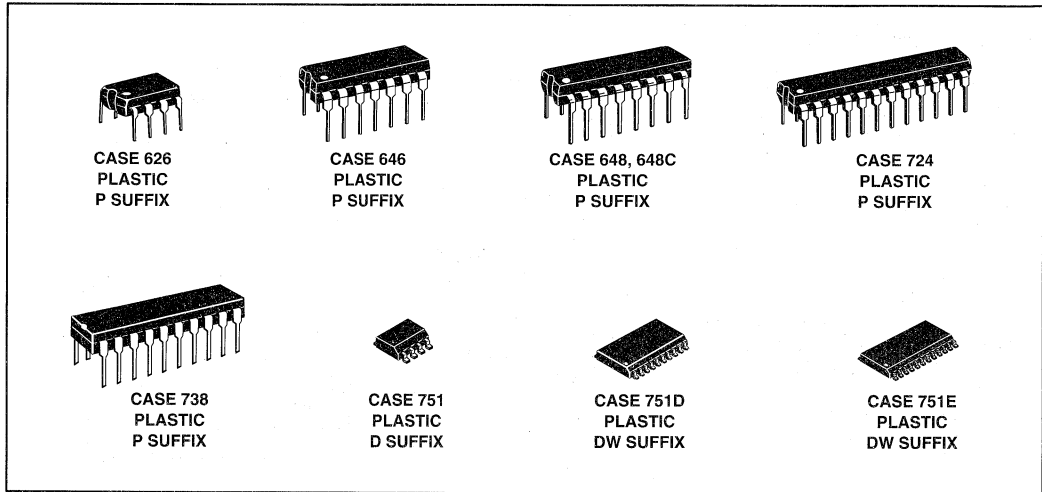

4

## Brushless DC Motor Controllers

Advances in magnetic materials technology and integrated circuits have contributed to the unprecedented rise in popularity of brushless DC motors. Linear control ICs are making the many features and advantages of brushless motors available at a much more economical price. Motorola offers a family of monolithic integrated brushless DC motor

controllers. These ICs provide a choice of control functions which allow many system features to be easily implemented at a fraction of the cost of discrete solutions. The following table summarizes and compares the features of Motorola's brushless motor controllers.

Table 22. Features Summary for Motorola Brushless DC Motor Controllers

Device	Operating Voltage Range (V)		Undervoltage Lockout	Internal Thermal Shutdown	Fwd/Rev Control	Sensor Electrical Phasing	Output Enable	Output Drivers			5.25 V Reference Output	Current Sense Comparator Input(s)	Error Amplifier	FAULT Output	Separate Drive Vc	Brake Input	Suffix/Package
	VCC	Vc						Totem Pole (Bottom)	Open Collector (Top)	6.25 V Reference Output							
MC33033	10-30		✓	✓	✓	60°/300° and 120°/240°	✓	✓	✓	✓	Noninv. Only	✓					P/738 DW/751D
MC33035	10-40	10-30	✓	✓	✓	60°/300° and 120°/240°	✓	✓	✓	✓	Noninv. and Inv.	✓	✓	✓	✓		P/724 DW/751E

## Motor Controllers: Brushless DC Motor Controllers (continued)

### MC33033P, DW

$T_A = -40^\circ$  to  $+85^\circ\text{C}$ , Case 738, 751D

The MC33033 is a lower cost second generation brushless DC motor controller which has evolved from the full featured MC33034 and MC33035 controllers. The MC33033 contains all of the active functions needed to implement a low cost open-loop motor control system. This IC has all of the key control and protection functions of the two full featured devices with the following secondary features deleted: separate drive-circuit supply and ground pins, the brake input, and the fault output signal. Like its MC33035 predecessor, the MC33033 has a control pin which allows the user to select  $60^\circ/300^\circ$  or  $120^\circ/240^\circ$  sensor electrical phasings.

Because of its low cost, the MC33033 can efficiently be used to control brush DC motors as well as brushless. A brush DC motor can be driven using two of the three drive output phases provided in the MC33033, while the Hall sensor input pins are selectively tied to  $V_{ref}$  or ground. Other features such as forward/reverse, output enable, speed control, current limiting, undervoltage lockout and internal thermal shutdown will still remain functional.

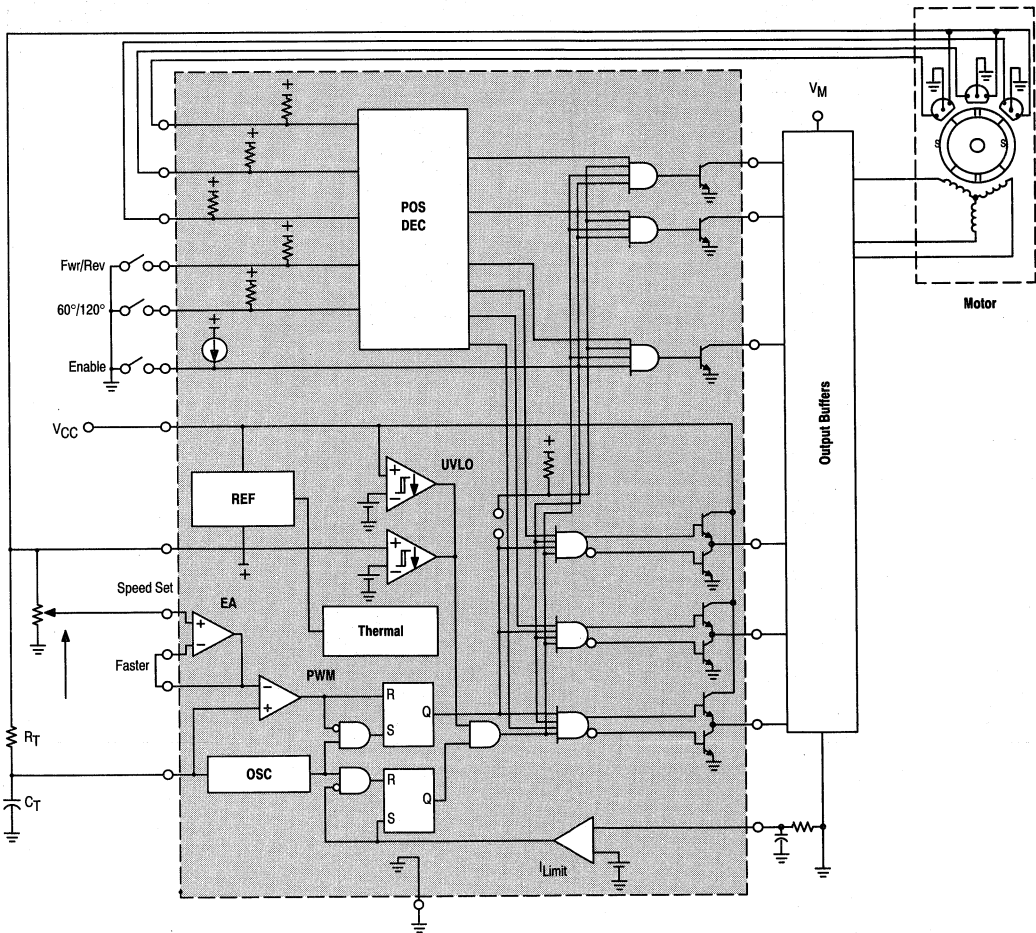



## Motor Controllers: Brushless DC Motor Controllers (continued)

### MC33035P, DW

$T_A = -40^\circ$  to  $+85^\circ\text{C}$ , Case 724, 751E

The MC33035 is a second generation high performance brushless DC motor controller which contains all of the active functions required to implement a full featured open-loop motor control system. While being pin-compatible with its MC33034 predecessor, the MC33035 offers additional features at a lower price. The two additional features provided by the MC33035 are a pin which allows the user to select

$60^\circ/300^\circ$  or  $120^\circ/240^\circ$  sensor electrical phasings, and access to both inverting and noninverting inputs of the current sense comparator. The earlier devices had two part numbers which were needed to support the different sensor phasings, and the inverting input to the current sense comparator was internally grounded. All of the control and protection features of the MC33034 are also provided in the MC33035.

4

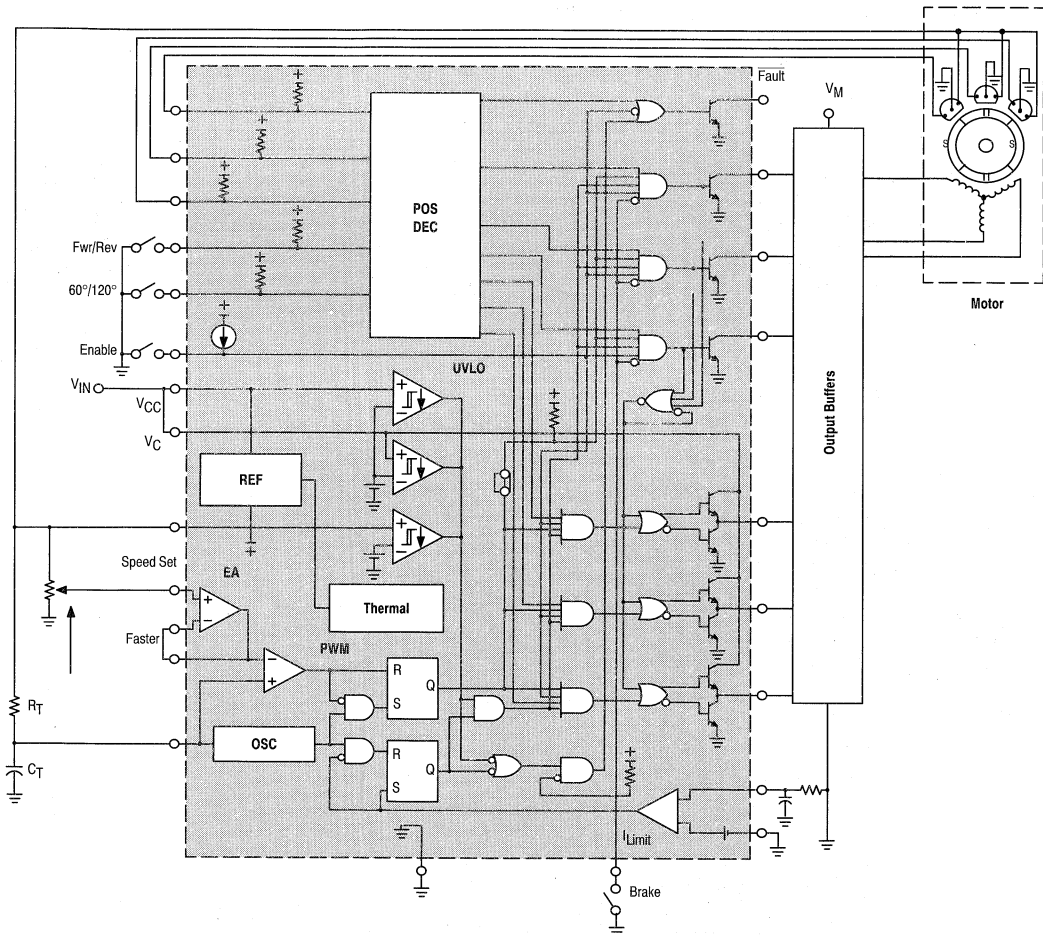

## Motor Controllers (continued)

### DC Servo Motor Controller/Driver

MC33030P

$T_A = -40^\circ$  to  $+85^\circ\text{C}$ , Case 648C

A monolithic dc servo motor controller providing all active functions necessary for a complete closed loop system. This device consists of an on-chip op amp and window comparator with wide input common mode range, drive and brake logic with direction memory, a power H switch driver capable of

1.0 A, independently programmable over current monitor and shutdown delay, and over voltage monitor. This part is ideally suited for almost any servo positioning application that requires sensing of temperature, pressure, light, magnetic flux, or any other means that can be converted to a voltage.

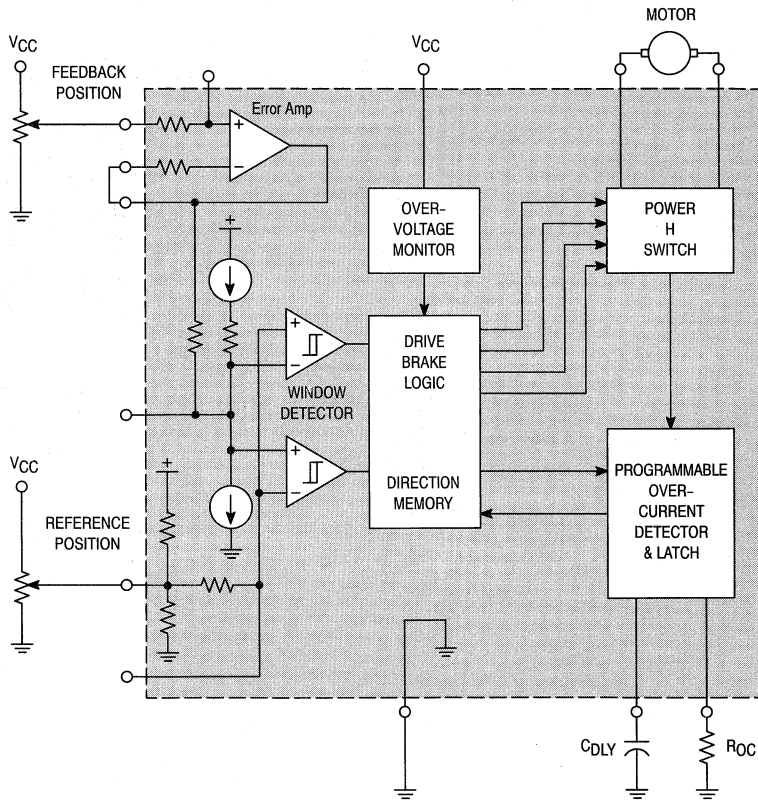

4

## Motor Controllers (continued)

# Closed-Loop Brushless Motor Adapter

### MC33039P, D

$T_A = -40^\circ$  to  $+85^\circ\text{C}$ , Case 626, 751

The MC33039P,D is a high performance close-loop speed control adapter specifically designed for use in brushless dc motor control systems. Implementation will allow precise speed regulation without the need for a magnetic or optical tachometer. These devices contain three input buffers each with hysteresis for noise immunity, three digital edge

detectors, a programmable monostable, and an internal shunt regulator. Also included is an inverter output for use in systems that require conversion of sensor phasing. Although this device is primarily intended for use with the MC33033/35 brushless motor controllers, it can be used cost effectively in many other closed-loop speed control applications.

4

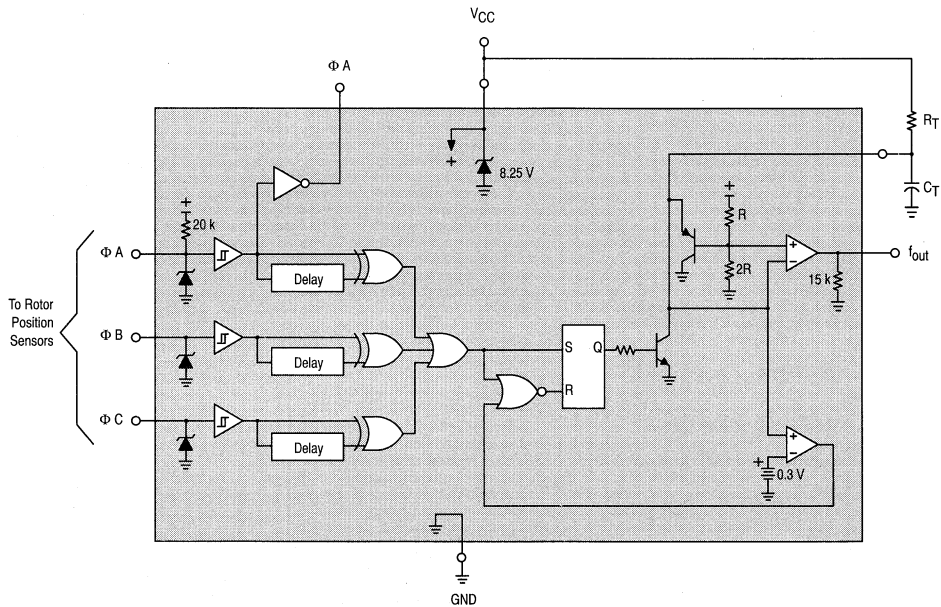

## Motor Controllers (continued)

# Stepper Motor Driver

### MC3479P

$T_A = 0^\circ$  to  $+70^\circ\text{C}$ , Case 648C

These Stepper Motor Drivers provide up to 500 mA of drive per coil for two phase 6.0 V to 24 V stepper motors. Control logic is provided to accept commands for clockwise, counter

clockwise and half or full step operation. The MC3479P has an added Output Impedance Control (OIC) and a Phase A drive state indicator (not available on SAA1042 devices).

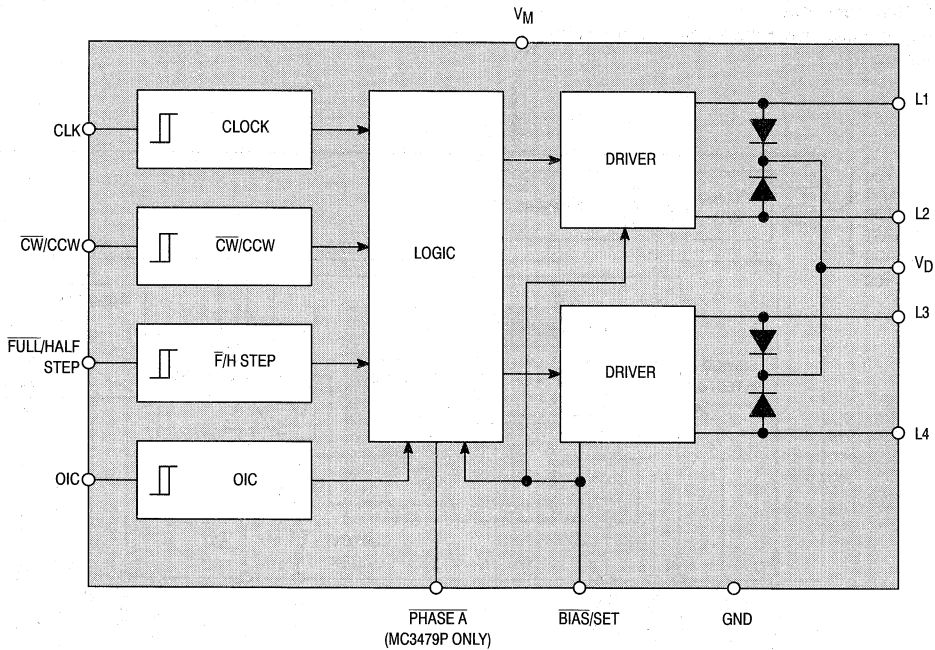

4

## Motor Controllers (continued)

# Universal Motor Speed Controllers

### TDA1085A

$T_A = 0^\circ$  to  $+70^\circ\text{C}$ , Case 648

This device contains all the necessary functions for the speed control of universal (ac/dc) motors in an open or closed loop configuration. Facility for defining the initial speed/time characteristic. The circuit provides a phase angle varied trigger pulse to the motor control triac.

- Guaranteed Full Wave Triac Drive
- Soft-Start from Power-up
- On-Chip Frequency/Voltage Converter and Ramp Generator

- Current Limiting Incorporated
- Direct Drive from AC Line

### TDA1085C

$T_A = -10^\circ$  to  $+120^\circ\text{C}$ , Case 648

Similar to the TDA1085A, but designed for commercial washing machine service.

4

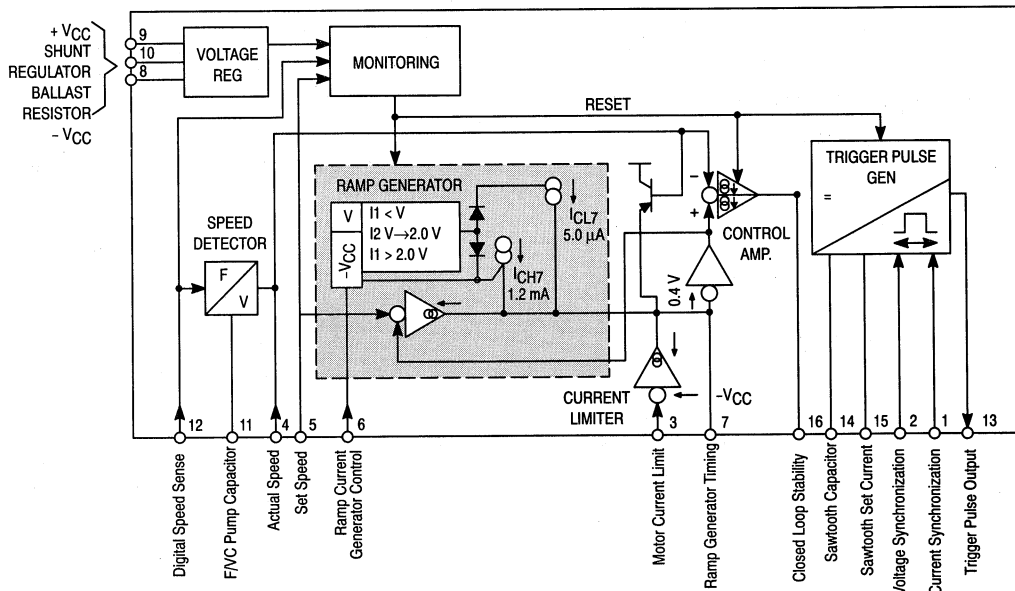

## Motor Controllers (continued)

# Triac Phase Angle Controller

### TDA1185A

$T_A = 0^\circ$  to  $+70^\circ\text{C}$ , Case 646

This device generates controlled triac triggering pulses and allows tachless speed stabilization of universal motors by an integrated positive feedback function.

- Low Cost External Components Count
- Optimum Triac Firing (2nd and 3rd Quadrants)
- Repetitive Trigger Pulses when Triac Current is Interrupted by Motor Brush Bounce

- Triac Current Sensed to Allow Inductive Loads
- Soft-Start
- Power Failure Detection and General Circuit Reset
- Low Power Consumption: 1.0 mA

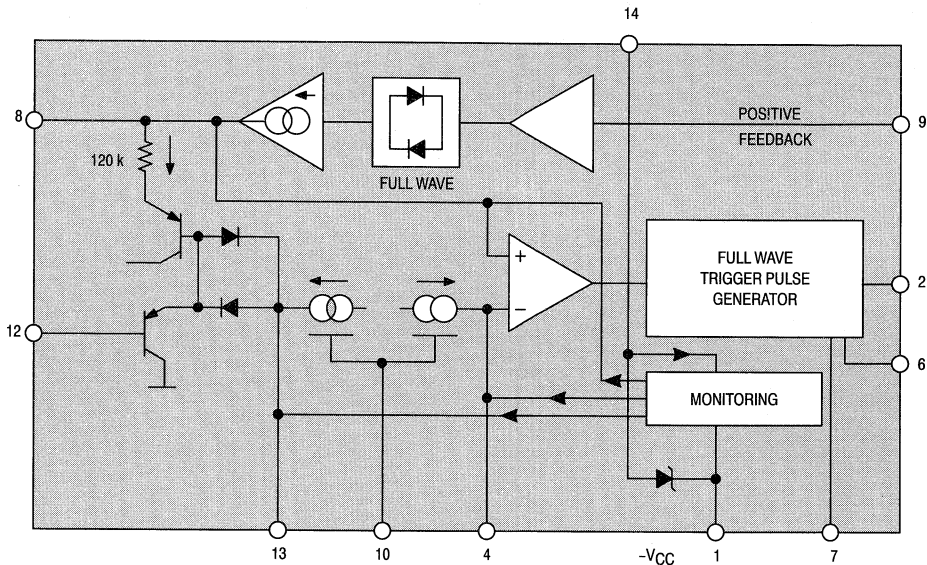

4

# 4

# Voltage References

---

## In Brief . . .

Motorola's line of precision voltage references is designed for applications requiring high initial accuracy, low temperature drift, and long term stability. Initial accuracies of  $\pm 1.0\%$ , and  $\pm 2.0\%$  mean production line adjustments can be eliminated. Temperature coefficients of 25 ppm/ $^{\circ}\text{C}$  max (typically 10 ppm/ $^{\circ}\text{C}$ ) provide excellent stability. Uses for the references include D/A converters, A/D converters, precision power supplies, voltmeter systems, temperature monitors, and many others.

	Page
Precision Low Voltage References . . . . .	4.4-2



## Precision Low Voltage References

A family of precision low voltage bandgap reference devices designed for applications requiring low temperature drift.

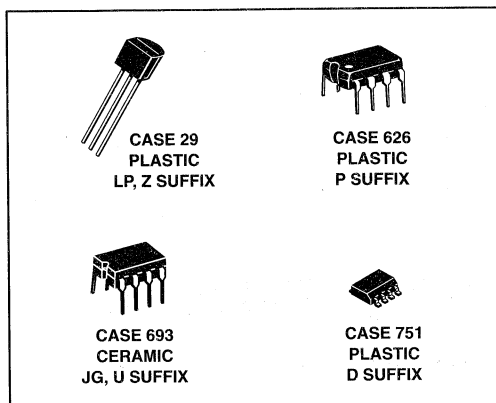

Table 23. Precision Low Voltage References

V <sub>out</sub> (V) Typ	I <sub>O</sub> (mA) Max	V <sub>out</sub> /T ppm/°C Max	Device		Regline (mV) Max	Regload (mV) Max	Suffix/ Package
			0° to +70°C	-55° to +125°C -40° to +85°C			
1.235 ± 12 mV 1.235 ± 25 mV	20	80 Typ	LM385BZ-1.2	LM285Z-1.2	(Note 1)	1.0 (Note 2)	Z/29
			LM385Z-1.2	(-40° to +85°C)			
2.5 ± 38 mV 2.5 ± 75 mV	20	80 Typ	LM385BZ-2.5	LM285Z-2.5	(Note 1)	2.0 (Note 3)	Z/29
			LM385Z-2.5	(-40° to +85°C)			
2.5 ± 25 mV	10	25	MC1403A	MC1503A	3.0/4.5 (Note 4)	10 (Note 6)	U/693, D/751
		40	MC1403				
		55		MC1503			
5.0 ± 50 mV	10	25	MC1404AU5		6.0 (Note 5)	10 (Note 6)	U/693
		40	MC1404U5				
		55		MC1504U5			
6.25 ± 60 mV	10	25	MC1404AU6		6.0 (Note 5)	10 (Note 6)	U/693
		40	MC1404U6				
		55		MC1504U6			
10 ± 100 mV	10	25	MC1404AU10		6.0 (Note 5)	10 (Note 6)	U/693
		40	MC1404U10				
		55		MC1504U10			
2.5 to 37	100	50 Typ	TL431C, AC, BC	TL431I, AI, BI	Shunt Reference Dynamic Impedance (z) ≤ 0.5 Ω	10 (Note 6)	LP/29, P/626 JG/693, D/751
				TL431M			

Notes: 1. Micropower Reference Diode Dynamic Impedance (z) ≤ 1.0 Ω at I<sub>R</sub> = 100 μA.

2. 10 μA ≤ I<sub>R</sub> ≤ 1.0 mA.

3. 20 μA ≤ I<sub>R</sub> ≤ 1.0 mA.

4. 4.5 V ≤ V<sub>in</sub> ≤ 15 V/15 V ≤ V<sub>in</sub> ≤ 40 V.

5. (V<sub>out</sub> + 2.5 V) ≤ V<sub>in</sub> ≤ 40 V.

6. 0 mA ≤ I<sub>L</sub> ≤ 10 mA.

# Data Conversion

---

## In Brief . . .

Motorola's line of digital-to-analog and analog-to-digital converters includes several well established industry standards, and many are available in various linearity grades so as to suit most any application.

The A/D converters have 7 and 8-bit flash converters suitable for NTSC and PAL systems, CMOS has 8 to 10-bit converters, as well as other high speed digitizing applications.

The D/A converters have 6 and 8-bit devices, video speed (for NTSC and PAL) devices, and triple video DAC with on-board color palette for color graphics applications.

	<b>Page</b>
Data Conversion .....	4.5-2
A-D Converters .....	4.5-2
CMOS .....	4.5-2
Bipolar .....	4.5-2
D-A Converters .....	4.5-3
CMOS .....	4.5-3
Bipolar .....	4.5-3
A-D/D-A Converters .....	4.5-3
CMOS — For Telecommunications .....	4.5-3
Package Overview .....	4.5-4

4

# Data Conversion

The line of data conversion products which Motorola offers spans a wide spectrum of speed and resolution/accuracy. Features, including bus compatibility, minimize external parts count and provide easy interface to microprocessor systems. Various technologies, such as Bipolar and CMOS, are utilized

to achieve functional capability, accuracy and production repeatability. Bipolar technology generally results in higher speed, while CMOS devices offer greatly reduced power consumption.

**Table 24. A-D Converter**

Resolution (Bits)	Device	Nonlinearity Max	Conversion Time/Rate	Input Voltage Range	Supplies (V)	Temperature Range (°C)	Suffix/Package	Comments
<b>CMOS</b>								
8	MC145040	± 1/2 LSB	10 μs	0 to V <sub>DD</sub>	+5.0 ± 10%	- 40 to +85 (Suffix 2 devices)	P/738 FN/775	Requires External Clock, 11-Ch MUX
	MC145041		20 μs				DW/751D	Includes Internal Clock, 11-Ch MUX
	MC14442					- 40 to +85	P/710 FN/776	μP Compatible 11-Ch MUX S.A.R.
	MC14549B/ MC14559B	Successive Approximation Registers			+3.0 to +18	- 55 to +125 - 40 to +85	L/620 P/648	Compatible with MC1408 S.A.R. 8-bit D-A Converter
Triple 8-Bit	MC44250	1 LSB	15 MHz	1.6 to 4.6 V	+5.0 ± 10%	0 to +70	FN/777	3 Separate Video Channels
10	MC145050	± 1 LSB	21 μs	0 to V <sub>DD</sub>	+5.0 ± 10%	- 40 to +125	P/738 DW/751D	Requires External Clock, 11-Ch MUX
	MC145051		44 μs					Includes Internal Clock, 11-Ch MUX
	MC145053						P/646 D/751A	Includes Internal Clock, 5-Ch MUX
8-10	MC14443/ MC14447	± 0.5% Full Scale	300 μs	Variable w/Supply	+5.0 to +18	- 40 to +85	P/648 DW/751G	μP Compatible, Single Slope, 6-Ch MUX
3-1/2 Digit	MC14433	± 0.05% ± 1 Count	40 ms	± 2.0 V ± 200 mV	+5.0 to +8.0 -2.8 to -8.0		P/709 DW/751E	Dual Slope
<b>Bipolar</b>								
7	MC10321	± 1/2 LSB	40 ns	0 to 2.0 V <sub>pp</sub> Max	+5.0 and -3.0 to -6.0	0 to +70	P/738 DW/751D	Video Speed, Gray Code TTL Outputs
8	MC10319	± 1 LSB					L/623 P/709 DW/751F Die Form	Video Speed Flash Converter, Internal Gray Code TTL Outputs

4

**Table 25. D-A Converters**

Resolution (Bits)	Device	Accuracy @ 25°C Max	Max Settling Time ( $\pm 1/2$ LSB)	Supplies (V)	Temperature Range (°C)	Suffix/Package	Comments
<b>CMOS</b>							
6	MC144110	—	—	+5.0 to +15	0 to +85	P/707	Serial input, Hex DAC, 6 outputs
						DW/751D	
	MC144111					P/646	Serial input, Quad DAC, 4 outputs
						DW/751G	
<b>Bipolar</b>							
8	DAC-08	$\pm 1$ LSB	150 ns	$\pm 4.5$ to $\pm 18$	0 to +70	EQ, HQ/620 CP, HP, EP/648 CD, ED/751B	High-speed Multiplying
		$\pm 1/2$ LSB					
		$\pm 1/4$ LSB	135 ns				
	MC1408	$\pm 1/2$ LSB	300 ns Typ	+5.0,	0 to +75	L8/620, P8/648	Multiplying
MC1508			-5.0 to -15	-55 to +125	L8/620		
4 x 3	MC10320	$\pm 1/4$ LSB	3.0 ns	+5.0 or $\pm 5.0$	0 to +70	L/733	125 MHz Color Graphics Triple DAC
	MC10320-1						90 MHz Color
8	MC10322	$\pm 1/2$ LSB	5.0 ns	+5.0, -5.2	-40 to +85	P/649	TTL 40 MHz Min
	MC10324			-5.2			ECL 40 MHz Min











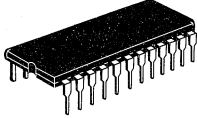

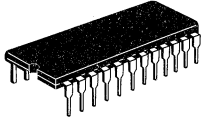

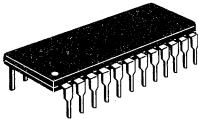
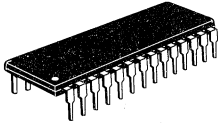
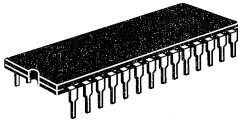
**4**

**Table 26. A-D/D-A Converters**

Resolution (Bits)	Device	Monotonicity (Bits)	Conversion Time	Input Voltage Range	Supplies (V)	Temperature Range (°C)	Suffix/Package	Comments
<b>CMOS — For Telecommunications</b>								
13	MC145402	13	62.5 $\mu$ s	$\pm 3.28$ V peak	$\pm 5.0$ to 6.0	-40 to +85	L/620	Digital signal processing (e.g., echo cancelling, high speed modems, phone systems with conferencing)

# Data Conversion Package Overview

4

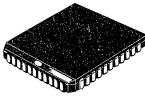
					
CASE 620 CERAMIC L, Q SUFFIX	CASE 623 CERAMIC L, L8 SUFFIX	CASE 646 PLASTIC P SUFFIX			
					
CASE 648 PLASTIC P SUFFIX	CASE 649 PLASTIC P SUFFIX	CASE 707 PLASTIC P SUFFIX			
					
CASE 709 PLASTIC P SUFFIX	CASE 710 PLASTIC P SUFFIX	CASE 733 CERAMIC L SUFFIX			
					
CASE 738 PLASTIC P SUFFIX	CASE 751A PLASTIC D SUFFIX	CASE 751B PLASTIC D SUFFIX	CASE 751D PLASTIC DW SUFFIX	CASE 751E PLASTIC DW SUFFIX	CASE 751F PLASTIC DW SUFFIX
					
CASE 751G PLASTIC DW SUFFIX	CASE 775 PLASTIC FN SUFFIX	CASE 776 PLASTIC FN SUFFIX	CASE 777 PLASTIC FN SUFFIX		

# Interface Circuits

---

## In Brief . . .

Described in this section is Motorola's line of interface circuits, which provide the means for interfacing microprocessor or digital systems to the external world, or to other systems.

Also included are devices which allow a microprocessor to communicate with its own array of memory and peripheral I/O circuits.

The line drivers, receivers, and transceivers permit communications between systems over cables of several thousand feet in length, and at data rates of up to several megahertz. The common EIA data transmission standards, several European standards, IEEE-488, and IBM 360/370 are addressed by these devices.

The peripheral drivers are designed to handle high current loads such as relay coils, lamps, stepper motors, and others. Input levels to these drivers can be TTL, CMOS, high voltage MOS, or other user defined levels. The display drivers are designed for LCD or LED displays, and provide various forms of decoding.

	<b>Page</b>
Enhanced Ethernet Serial Transceiver (EEST) . . . . .	4.6-2
High Performance Decoder Driver/Sink Driver . . . . .	4.6-3
ISO 8802-3[IEEE 802.3] 10BASE-T Transceiver . . . . .	4.6-3
Microprocessor Bus Interface . . . . .	4.6-4
Address and Control Bus Extenders . . . . .	4.6-4
Microprocessor Data Bus Extenders . . . . .	4.6-4
Magnetic Read/Write . . . . .	4.6-4
Single-Ended Bus Transceivers . . . . .	4.6-5
Line Receivers . . . . .	4.6-5
General Purpose . . . . .	4.6-5
EIA Standard . . . . .	4.6-5
Line Drivers . . . . .	4.6-6
General Purpose . . . . .	4.6-6
360/370 I/O Interface . . . . .	4.6-6
EIA Standard . . . . .	4.6-6
Line Transceivers . . . . .	4.6-7
EIA-232-D/V.28 CMOS Drivers/Receivers . . . . .	4.6-7
Peripheral Drivers . . . . .	4.6-7
IEEE 802.3 Transceivers . . . . .	4.6-8
CMOS Display Drivers . . . . .	4.6-8
Package Overview . . . . .	4.6-10

# Enhanced Ethernet Serial Transceiver (EEST)

## MC68160FB

T<sub>A</sub> = 0° to +70°C, Case 848D

The MC68160 is a BiCMOS integrated circuit for use in ethernet applications. The IC integrates the Attachment Unit Interface (AUI), the 10BASE-T interface and the communications controller interface. The communications interface is compatible with Motorola, AMD, Intel, National Semiconductor, Fujitsu, Western Digital controllers and is set by the bias of external pins.

Connection to the twisted pair media is accomplished with common 10BASE-T filters and transformers. The AUI requires standard transformers. (The EEST is packaged in a 52-pin Thin Quad Flat Pack.)

4

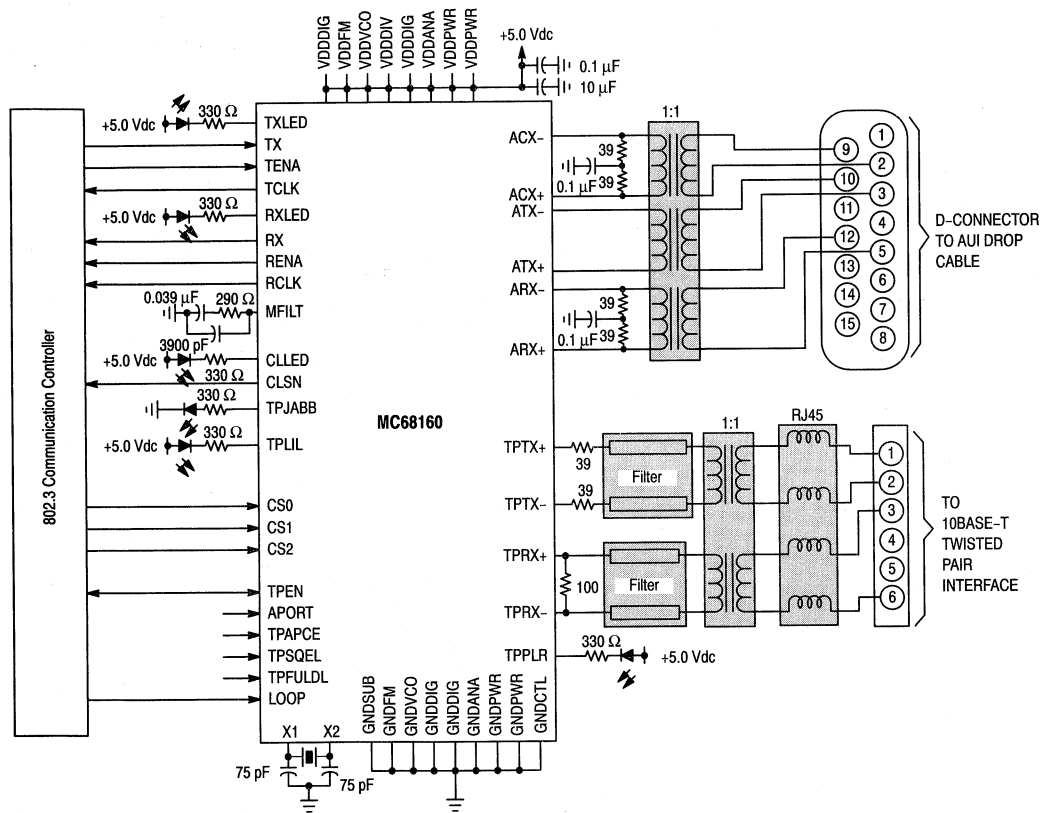

Communication Controller Selection

CS0	CS1	CS2	802.3 Communication Controller
1	1	0	Motorola MC68360, AMD 7990 & 79C900
0	1	0	Intel 8256, 82590, 82593, 82596
1	0	0	Fujitsu MB86950, MB86960
0	0	0	National 8390, 83C690, 83932B
1	1	1	Standby Low Current Mode

# High Performance Decoder Driver/Sink Driver

MC34142DW, FN

T<sub>A</sub> = 0° to +70°C, Case 751F, 776

The MC34142 is a high performance 4 to 16 multiplexed driver. This integrated circuit features a 4 to 16 decoder, 16 open drain N-channel MOS output devices with clamp diodes. The outputs are controlled by 4 address inputs, an output enable, and a chip enable.

Typical applications include solenoid drivers, LED drivers, lamp drivers, and relay drivers.

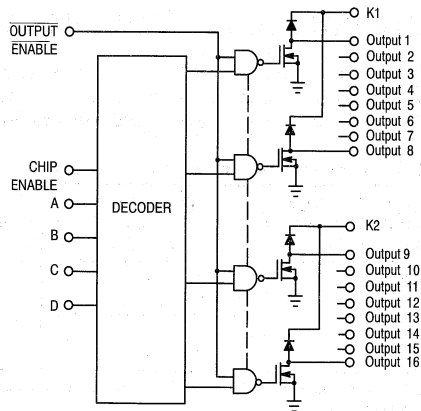

# ISO 8802-3[IEEE 802.3] 10BASE-T Transceiver

MC34055DW, P

T<sub>A</sub> = 0° to +70°C, Case 751E, 724

The Motorola 10BASE-T transceiver, designed to comply with the ISO 8802-3[IEEE 802.3] 10BASE-T specification, will support a Medium Dependent Interface (MDI) in an embedded Media Attachment Unit (MAU). The interface supporting the Data Terminal Equipment (DTE) is TTL, CMOS, and raised ECL compatible, and the interface to the

Twisted Pair (TP) media is supported through standard 10BASE-T filters and transformers. Differential data intended for the TP media is provided a 50 ns pre-emphasis and data at the TP receiver, is screened by Smart Squelch circuitry for specific threshold, pulse width, and sequence requirements.

4

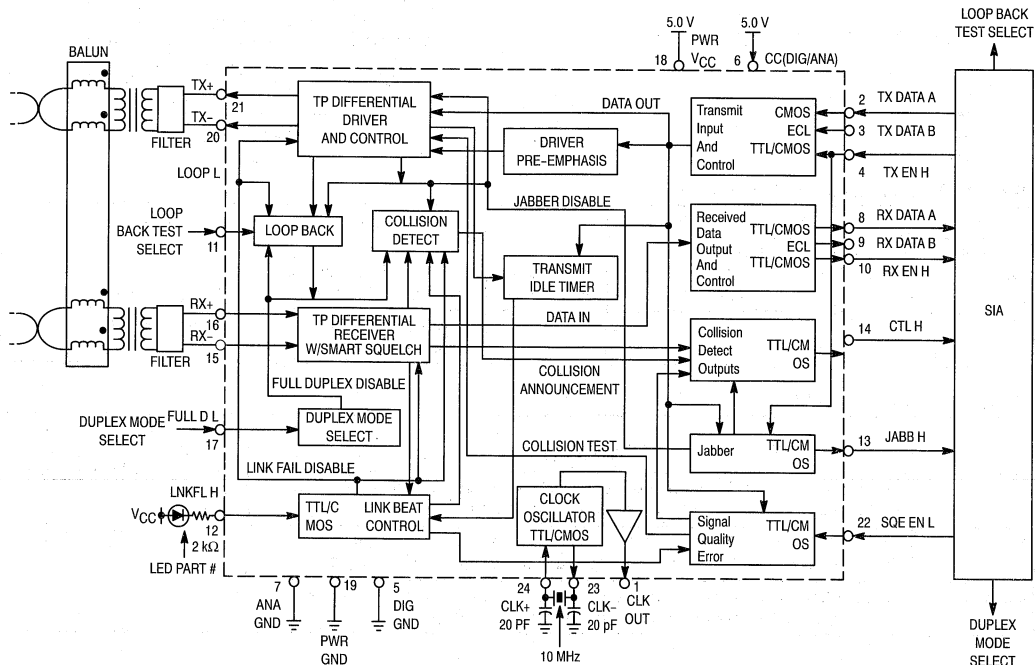



# Microprocessor Bus Interface

Motorola offers a spectrum of line drivers and receivers which provide interfaces to many industry standard specifications. Many of the devices add key operational

features, such as hysteresis, short circuit protection, clamp diode protection, or special control functions.

**Table 27. Address and Control Bus Extenders**

VOL @ 48 mA Max	VOH @ -5.2 mA Min	Propagation Delay Max (ns)	Buffers Per Package	Device	Suffix/Package	Comments
0.5	2.4	13	6	MC8T97/ MC6887	L/620 P/648	Noninverting
		11		MC8T98/ MC6888		Inverting

Note: These devices are designed to extend the drive capabilities of today's standard microprocessors. All devices are fabricated with Schottky TTL technology for high speed.

### Hex 3-State Buffers/Inverters

**MC8T97/MC6887**(1) — Noninverting

**MC8T98/MC6888**(1) — Inverting

T<sub>A</sub> = 0° to +75°C

The noninverting MC8T97/MC6887 and inverting MC8T98/MC6888 provide two Enable inputs, one controlling four buffers and the other controlling the remaining two buffers.

(1) These devices may be ordered by either of the paired numbers.

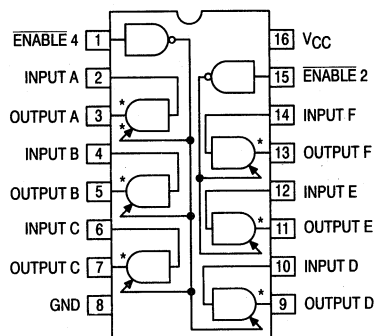

\*Add inverter for MC6888/MC8T98.

**Table 28. Microprocessor Data Bus Extenders**

Driver Characteristics		Receiver Characteristics		Transceivers Per Package	Device	Suffix/Package	Comments
Output Current (mA)	Propagation Delay Max (ns)	Propagation Delay Max (ns)					
48	14	14		4	MC8T26A (MC6880A)	P/648 L/620	Inverting Logic

**Table 29. Magnetic Read/Write**

Device	Comments	T <sub>A</sub> (°C)	Suffix/Package
MC3471	Tunnel/Straddle Erase Controller. Provides entire interface between floppy disk heads and the head control and write data signals for straddle erase heads.	0 to +70	P/738
MC3470, A	Floppy Disk Read Amplifier System. A monolithic read amplifier system for reading differential AC signals from the magnetic head and converting to a digital output.		P/707
MC34167	Magnetic Tape Sense Amplifier. Trace independent preamplifiers with individual gain control. Optimized for use with 9-track magnetic tape memory systems.		

# Single-Ended Bus Transceivers

**Table 30. For Instrumentation Bus, Meets GPIB/IEEE Standard 488**

Driver Characteristics		Receiver Characteristics		Transceivers Per Package	Device	Suffix/Package	Comments
Output Current (mA)	Propagation Delay Max (ns)	Propagation Delay Max (ns)					
48	30	50	8	MC3447	P/3/724 L/623 P/649	Input hysteresis, open collector, 3-state outputs with terminations	
	17	25	4	MC3448A	P/648 D/751B L/620	Input hysteresis, open collector, 3-state outputs with terminations	

**Table 31. For High-Current Party-Line Bus for Industrial and Data Communications**

Driver Characteristics		Receiver Characteristics		Transceivers Per Package	Device	Suffix/Package	Comments
Output Current (mA)	Propagation Delay Max (ns)	Propagation Delay Max (ns)					
100	15	15	4	MC26S10	P/648 D/751B L/620	Open collector, outputs, common enable	

## Line Receivers

**Table 32. General Purpose**

S = Single Ended D = Differential	Type (1) of Output	t <sub>prop</sub> Delay Time Max (ns)	Party Line Operation	Strobe or Enable	Power Supplies (V)	Device	Suffix/Package	Receivers Per Package	Companion Drivers	Comments
D	TP OC	25	✓	✓	± 5.0	MC3450 MC3452	D/751B P/648 L/620	4	MC3453	Quad version of MC75107/108
	TP OC		✓	✓		MC75107 MC75108	P/646 L/632	2	MC75S110	Dual version of MC3450/2
S	TP	30	✓	✓	+ 5.0	MC3437	P/648 L/620	6		Input hysteresis

(1) OC = Open Collector, TP = Totem-pole output.

**Table 33. EIA Standard**

S = Single Ended D = Differential	Type of Output	t <sub>prop</sub> Delay Time Max (ns)	Party Line Operation	Strobe or Enable	Power Supplies (V)	Device	Suffix/Package	Receivers Per Package	Companion Drivers	Comments
S	TP	4000	—	—	+ 5.0	MC14C89B MC14C89B	P/646 D/751A	4	MC14C88B	EIA-232-D/ EIA-562
S	R(2)	85	—	—		MC1489 MC1489A	D/751A P/646 L/632		MC1488	EIA-232-D
S, D	TP	30	✓	✓		AM26LS32 MC3486	P/648 D/751B L/620		AM26LS31 MC3487	EIA-422/423

4

**Table 33. EIA Standard (continued)**

S = Single Ended D = Differential	Type of Output	t <sub>prop</sub> Delay Time Max (ns)	Party Line Operation	Strobe or Enable	Power Supplies (V)	Device	Suffix/Package	Receivers Per Package	Companion Drivers	Comments
		35	✓	✓		SN75173 SN75175	N/648 D/751B		MC75172B MC75174B	EIA-422/423/ 485

(2) R = Resistor Pull-up, TP = Totem-pole output.

## Line Drivers

**Table 34. General Purpose**

Output Current Capability (mA)	t <sub>prop</sub> Delay Time Max (ns)	S = Single Ended D = Differential	Party Line Operation	Strobe or Enable	Power Supplies (V)	Device	Suffix/Package	Receivers Per Package	Companion Drivers	Comments
15	15	D	✓	✓	± 5.0	MC3453	P/648 L/620	4	MC3450 MC3452	Quad version of MC75S110
						MC75S110	P/646 L/632	2	MC75107 MC75108	Dual version of MC3453

**Table 35. 360/370 I/O Interface**

**4**

60	45	S	✓	✓	+ 5.0	MC3481	P/648 L/620	4		Short circuit Fault flag
						MC3485	P/648			

**Table 36. EIA Standard**

Output Current Capability (mA)	t <sub>prop</sub> Delay Time Max (ns)	S = Single Ended D = Differential	Party Line Operation	Strobe or Enable	Power Supplies (V)	Device	Suffix/Package	Receivers Per Package	Companion Drivers	Comments			
85	35	D	✓	✓	+ 5.0	MC75172B MC75174B	N/648 J/620	4	SN75173 SN75175	EIA-485			
48	20					MC3487	P/648 D/751B L/620		MC3486	EIA-422 with 3-state outputs			
						AM26LS31	PC/648 DC/620		AM26LS32				
						MC26LS31	D/751B		MC26LS32				
20		S	—	—	± 12	MC3488A (μA9636A)	P1/626 D/751B U/693	2	MC3486 AM26LS32	EIA-423/232-D			
15	3500						± 7.0 to ± 12		MC14C88B	P/646 D/751A	4	MC14C89B MC14C89B	EIA-232-D/ EIA-562
10	350						± 9.0 to ± 12		MC1488	P/646 D/751A L/632		MC1489 MC1489A	EIA-232-D
60	300	S/D		422 ✓ 423 —	± 5.0	AM26LS30	PC/648	2 (422) 4 (423)	AM26LS32 MC3486	EIA-422 EIA-423			
						MC26LS30	D/751B		MC26LS32	Switchable			

**Table 37. Line Transceiver**

Driver Prop Delay (Max ns)	Receiver Prop Delay Max (ns)	DE = Driver Enable RE = Receiver Enable	Party Line Operation	Power Supplies (V)	Device	Suffix/Package	Drivers Per Package	Receivers Per Package	EIA Standard
20	30	DE, RE	✓	+ 5.0	MC34050	D/751B P/648	2	2	EIA-422
		DE	✓		MC34051	D/751B P/648			

**Table 38. EIA-232-D/V.28 CMOS Drivers/Receivers**

Device	Suffix/Package	Pins	Drivers	Receivers	Power Supplies (V)	Features
MC145403	P/738 DW/751D	20	3	5	± 5.0 to ± 12	
MC145404			4	4		
MC145405			5	3		
MC145406	P/648 DW/751G	16	3		+ 5.0	Charge Pump
MC145407	P/738 DW/751D	20				
MC145408	P/724 DW/751E	24	5	5	± 5.0 to ± 12	
MC145705	P/738 DW/751D	20	2	3	+ 5.0	Charge Pump, Power Down
MC145706			3	2		
MC145707			P/724 DW/751E	24		

**4**

**Table 39. Peripheral Drivers**

Output Current Capability (mA)	Input Capability	Propagation Delay Time Max (µs)	Output Clamp Diode	Off State Voltage Max (V)	Device	Drivers Per Package	Suffix/Package	Logic Function		
300	TTL, DTL	1.0	✓	70	MC1472	2	P1/626	NAND		
500	TTL, CMOS, PMOS						ULN2801	8	A/707	Invert
	14 V to 25 V PMOS				50	ULN2802				
	TTL, CMOS					ULN2803				
	6.0 V to 15 V MOS					ULN2804				
	TTL, CMOS PMOS					MC1411,B (ULN2001A)	7	P/648		
	14 V to 25 V PMOS					MC1412,B (ULN2002A)				
	TTL, 5.0 V CMOS					MC1413,B (ULN2003A)				
	8.0 V to 18 V MOS					MC1416,B (ULN2004A)				

**Table 39. Peripheral Drivers (continued)**

Output Current Capability (mA)	Input Capability	Propagation Delay Time Max (μs)	Output Clamp Diode	Off State Voltage Max (V)	Device	Drivers Per Package	Suffix/Package	Logic Function
	TTL, 5.0 V CMOS	0.15		35	MC34142	16	FN/776 DW/751F	1 of 16 Power Decoder
1500	TTL, 5.0 V CMOS	1.0		50	ULN2068B	4	B/648C	Invert

**Table 40. IEEE 802.3 Transceivers**

Device	Power Supply	10 BaseT	NRZ	IEEE	Comments	Suffix/Package
MC34055	+ 5.0 Vdc	Transmit and Receive over 4 Pins	Raised ECL, CMOS	802.3 Type 10BaseT	Transceiver with non–return to zero (NRZ) interface. Intended for but not restricted to concentrators and repeater applications.	DW/751E P/724
MC68160			TTL, CMOS	802.3 Type 10BaseT/AUI/NRZ	Interfaces gluelessly to Motorola's MC68360 communications controller.	P/648

## CMOS Display Drivers

These CMOS devices include digit as well as matrix drivers for LEDs, LCDs, and VFDs. They find applications over a wide

range of end equipment such as instruments, automotive dash boards, home computers, appliances, radios and clocks.

**4**

**Table 41. Display Drivers**

Display Type	Input Format	Drive Capability Per Package	On-Chip Latch	Display Control	Segment Drive Current	Device
LCD (Direct Drive)	Parallel BCD	7 Segments	✓	Blank	≈ 1.0 mA	MC14543B
				Blank, Ripple Blank		MC14544B
Muxed LCD (1/4 Mux)	Serial Binary [Compatible with the Serial Peripheral Interface (SPI) on CMOS MCUs]	33 Segments or Dots			20 μA	MC145453
		48 Segments or Dots				MC145000
LED, Incandescent, Fluorescent <sup>(1)</sup>	Parallel BCD	7 Segments		Blank, Lamp Test	25 mA	MC14511B
				Blank, Ripple Blank, Lamp Test		MC14513B
Muxed LED (1/5 Mux)	Serial Binary [Compatible with the Serial Peripheral Interface (SPI) on CMOS MCUs]	4 Digits + Decimals	✓	Oscillator (Scanner)	50 mA (Peak)	MC14499
		5 Characters + Decimals or 25 Lamps		Oscillator (Scanner), Low–Power Mode, Dimming		0 to 35 mA (Peak) Adjustable
LED (Direct Drive)	Parallel Hex	7 Segments + A thru F Indicator			10 mA <sup>(2)</sup>	MC14495♦1
(Interfaces to Display Drivers)	Parallel BCD	7 Segments		Ripple Blank, Enable		MC14558B

<sup>(1)</sup> Absolute maximum working voltage = 18 V.

<sup>(2)</sup> On–chip current–limiting resistor.

**Table 42. Functions**

Device	Function	Package
MC14489	Multi-Character LED Display/Lamp Driver	738, 751D
MC14495♦1	Hexadecimal-to-7 Segment Latch/Decoder ROM/Driver	648, 751G
MC14499	4-Digit 7-Segment LED Display Decoder/Driver with Serial Interface	707, 751D
MC14511B	BCD-to-7-Segment Latch/Decoder/Driver	620, 648
MC14513B	BCD-to-7-Segment Latch/Decoder/Driver with Ripple Blanking	726, 707
MC14543B	BCD-to-7-Segment Latch/Decoder/Driver for Liquid Crystals	620, 648
MC14544B	BCD-to-7-Segment Latch/Decoder/Driver with Ripple Blanking	726, 707
MC14547B	High-Current BCD-to-7-Segment Decoder/Driver	620, 648
MC14558B	BCD-to-7-Segment Decoder	620, 648
MC145000	48-Segment Serial Input Multiplexed LCD Driver (Master)	709, 776
MC145001	44-Segment Serial Input Multiplexed LCD Driver (Slave)	707, 776
MC145453	33-Segment, Non-Multiplexed LCD Driver with Serial Interface	711, 777

♦Replace ♦ with package identifier (see product data).

**4**

# Interface Package Overview



CASE 620  
CERAMIC  
D, DC, J, L SUFFIX

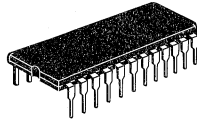

CASE 623  
CERAMIC  
L SUFFIX



CASE 626  
PLASTIC  
P1 SUFFIX



CASE 632  
CERAMIC  
L SUFFIX



CASE 646  
PLASTIC  
P SUFFIX



CASE 648, 648C  
PLASTIC  
B, N, P, PC SUFFIX

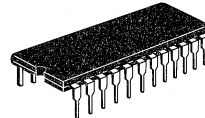

CASE 649  
PLASTIC  
P SUFFIX



CASE 707  
PLASTIC  
A SUFFIX

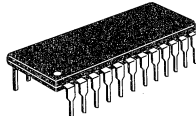

CASE 709  
PLASTIC  
P SUFFIX

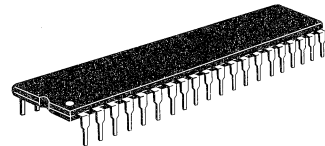

CASE 711  
PLASTIC  
P SUFFIX



CASE 724  
PLASTIC  
P3 SUFFIX



CASE 726  
CERAMIC  
L SUFFIX



CASE 738  
PLASTIC  
P SUFFIX



CASE 751A  
PLASTIC  
D SUFFIX



CASE 751B  
PLASTIC  
D SUFFIX



CASE 751D  
PLASTIC  
D SUFFIX



CASE 751E  
PLASTIC  
DW SUFFIX



CASE 751G  
PLASTIC  
DW SUFFIX



CASE 776  
PLASTIC  
FN SUFFIX



CASE 777  
PLASTIC  
FN SUFFIX



CASE 848D  
PLASTIC  
P SUFFIX

4

# Communication Circuits

## In Brief . . .

### RF

Radio communication has greatly expanded its scope in the past several years. Once dominated by public safety radio, the 30 to 1000 MHz spectrum is now packed with personal and low cost business radio systems. The vast majority of this equipment uses FM or FSK modulation and is targeted at short range applications. From mobile phones and VHF marine radios to garage door openers and radio controlled toys, these new systems have become a part of our lifestyle. Motorola Linear has focused on this technology, adding a wide array of new products including complete receivers processed in our exclusive 3.0 GHz MOSAIC® 1.5 process. New surface mount packages for high density assembly are available for all of these products, as is a growing family of supporting application notes and development kits.

### Telephone & Voice/Data

Traditionally, an office environment has utilized two distinctly separate wired communications systems – Telecommunications and Data communications. Each had its individual hardware components complement, and each required its own independent transmission line system: twisted wire pairs for Telecom and relatively high priced coaxial cable for Datacom. But times have changed. Today, Telecom and Datacom coexist comfortably on inexpensive twisted wire pairs and use a significant number of components in common. This has led to the development and enhancement of PBX (Private Branch Exchanges) to the point where the long heralded “office of the future,” with simultaneous voice and data communications capability at each station, is no longer of the future at all. The capability is here today!

Motorola Semiconductor serves a wide range of requirements for the voice/data marketplace. We offer both CMOS and Linear technologies, each to its best advantage, to upgrade the conventional analog voice systems and establish new capabilities in digital communications. Early products, such as the solid-state single-chip crosspoint switch, the more recent monolithic Subscriber-Loop-Interface Circuit (SLIC), a single-chip Codec/Filter (Mono-Circuit), the Universal Digital Loop Transceivers (UDLT), basic rate ISDN (Integrated Services Digital Network), and single-chip telephone circuits are just a few examples of Motorola leadership in the voice/data area.

### Page

RF Communications	
Wideband	4.7-2
Wideband Single Conversion Receivers	4.7-2
Narrowband Single Conversion Receivers	4.7-2
Narrowband Dual Conversion Receivers	4.7-2
Transmitter	4.7-3
Balanced Modulator/Demodulator	4.7-3
Telecommunications	
Subscriber Loop Interface Circuits	4.7-7
PBX Architecture (Analog Transmission)	
PCM Mono-Circuits	4.7-8
Dual Tone Multiple Frequency Receiver	4.7-11
Crosspoint Switches	4.7-11
ISDN Voice/Data Circuits	
Integrated Services Digital Network	4.7-11
U-Interface Transceiver	4.7-12
S/T-Interface Transceivers	4.7-12
Dual Data Link Controller	4.7-13
Voice/Data Communication (Digital Transmission)	4.7-14
Universal Digital Loop Transceiver	4.7-14
ISDN Universal Digital Loop Transceiver II	4.7-15
Data Set Interface Circuit	4.7-15
Electronic Telephone Circuit	4.7-16
Audio Control Circuit	4.7-16
Dial Circuits	4.7-16
Tone Fingers	4.7-17
Speech Networks	4.7-18
Speakerphone	
Voice Switched Speakerphone Circuit	4.7-20
Voice Switched Speakerphone with	
μProcessor Interface	4.7-21
Voice Switched Speakerphone Circuit	4.7-22
Telephone Accessory Circuits	
Audio Amplifier	4.7-24
Current Mode Switching Regulator	4.7-24
300 Baud FSK Modems	4.7-25
ADPCM Transcoder	4.7-25
Bit Rate Generators	4.7-25
Calling Line Identification (CLID) Receiver	4.7-26
CVSD Modulator/Demodulator	4.7-27
Summary of Bipolar Telecommunications Circuits	4.7-28
Phase-Locked-Loop Components	4.7-30
PLL Frequency Synthesizers	4.7-30
Intended Applications	4.7-30
Additional Phase-Locked-Loop Functions	4.7-31
Package Overview	4.7-32

4



# RF Communications

**Table 43. Wideband (FM/FSK) IFs**

Device	V <sub>CC</sub>	I <sub>CC</sub>	Sensitivity (Typ)	IF	Mute	RSSI	Max Data Rate	Notes	Suffix/Package
MC13055	3-12 V	25 mA	20 μV	40 MHz	✓	✓	2.0 Mb	Wideband Data IF	P/648
MC13155	3-6 V	10 mA	100 μV	70 MHz	—		12 Mb	Video Speed FM IF	D/751B

**Table 44. Wideband Single Conversion Receivers — VHF**

Device	V <sub>CC</sub>	I <sub>CC</sub>	Sensitivity (Typ)	RF Input	IF	Mute	RSSI	Max Data Rate	Notes	Suffix/Package
MC3356	3-9 V	25 mA	30 μV	200MHz	10.7MHz	✓	✓	500 kb	Includes front end mixer/L.O.	P/738 DW/751D
MC13156	2-7 V	3.0 mA	2.0 μV		21.4MHz	—			CT-2 FM/Demodulator	DW/751E

**Table 45. Narrowband Single Conversion Receivers — VHF**

Device	V <sub>CC</sub>	I <sub>CC</sub>	12 dB SINAD Sensitivity (Typ)	RF Input	IF	Mute	RSSI	Max Data Rate	Notes	Suffix/Package
MC3357	4-8 V	5.0 mA	5.0 μV	45 MHz	455 kHz	✓	—	> 4.8 kb	Ceramic Quad Detector/Resonator	P/648
MC3359	4-9 V	7.0 mA	2.0 μV						Scan output option	P/707 DW/751D
MC3361B	2-8 V	6.0 mA	1.0 μV	60 MHz	75 MHz	—	—	1.2 kb	Lowest cost receiver	P648 D/751B
MC3367	1-5 V	1.0 mA		75 MHz					1 Cell Operation	DW/751F
MC3371	2-8 V	6.0 mA	1.0 μV	60 MHz	60 MHz	✓	✓	> 4.8 kb	RSSI	P/648 D/751B
MC3372									RSSI, Ceramic Quad Detector/Resonator	

4

**Table 46. Narrowband Dual Conversion Receivers — FM/FSK — VHF**

Device	V <sub>CC</sub>	I <sub>CC</sub>	12 dB SINAD Sensitivity (Typ)	RF Input	IF1	IF2 (Limiter In)	Mute	RSSI	Data Rate	Notes	Suffix/Package
MC3362	2.0 V to 7.0 V	3.0 mA	0.7 μV	180 MHz	10.7 MHz	455 kHz	—	✓	> 4.8 kb	Includes buffered VCO output	P/724 DW/751E
MC3363		4.0 mA	0.4 μV				Includes RF amp/mute			DW/751F	
MC3335		0.7 μV	Low cost version				DW/751D				
MC13135		3.5 mA	200 MHz	—	—	—	—	—	> 50 kb	Voltage buffered RSSI	DW/751E
MC13136										High level IF resonator drive	

## RF Communications (continued)

**Table 47. Transmitters — AM/FM/FSK**

Device	V <sub>CC</sub>	I <sub>CC</sub>	P <sub>out</sub>	Max RF Freq Out	Max Mod Freq	Notes	Suffix/Package
MC2831A	3.0 V to 8.0 V	5.0 mA	-30 dBm	50 MHz	50 kHz	FM transmitter. Includes low battery checker, tone oscillator	P/648 D/751B
MC2833		10 mA	-30 dBm to +10 dBm	150 MHz		FM transmitter. Includes two frequency multiplier/amplifier transistors	
MC13175	2.0 V to 5.0 V	40 mA	8.0 dBm	500 MHz	5.0 MHz	AM/FM transmitter. Single frequency PLL $f_{out} = 8 \times f_{ref}$	D/751B
MC13176				1.0 GHz			

**Table 48. Balanced Modulator/Demodulator**

Device	V <sub>CC</sub>	I <sub>CC</sub>	Function	Suffix/Package
MC1596 MC1496	5.0 V to 30 V	10 mA	Carrier Balance >50 dB General purpose balanced modulator/ demodulator for AM, SSB, FM detection	L/632 P/646 D/751A

4

# Wideband FM IF

## MC13155D

$T_A = -40^\circ$  to  $+85^\circ\text{C}$ , Case 648, 751B

The MC13155D is a complete wideband FM detector designed for satellite TV and other wideband data and analog FM applications. Devices may be cascaded for higher IF gain and extended Receive Signal Strength Indicator (RSSI) range.

- 12 MHz Video/Baseband Demodulator
- Ideal for Wideband Data and Analog FM Systems
- Limiter Output for Cascade Operation
- Low Drain Current: 7.0 mA
- Low Supply Voltage: 3.0 to 6.0 V
- Operates to 300 MHz

4

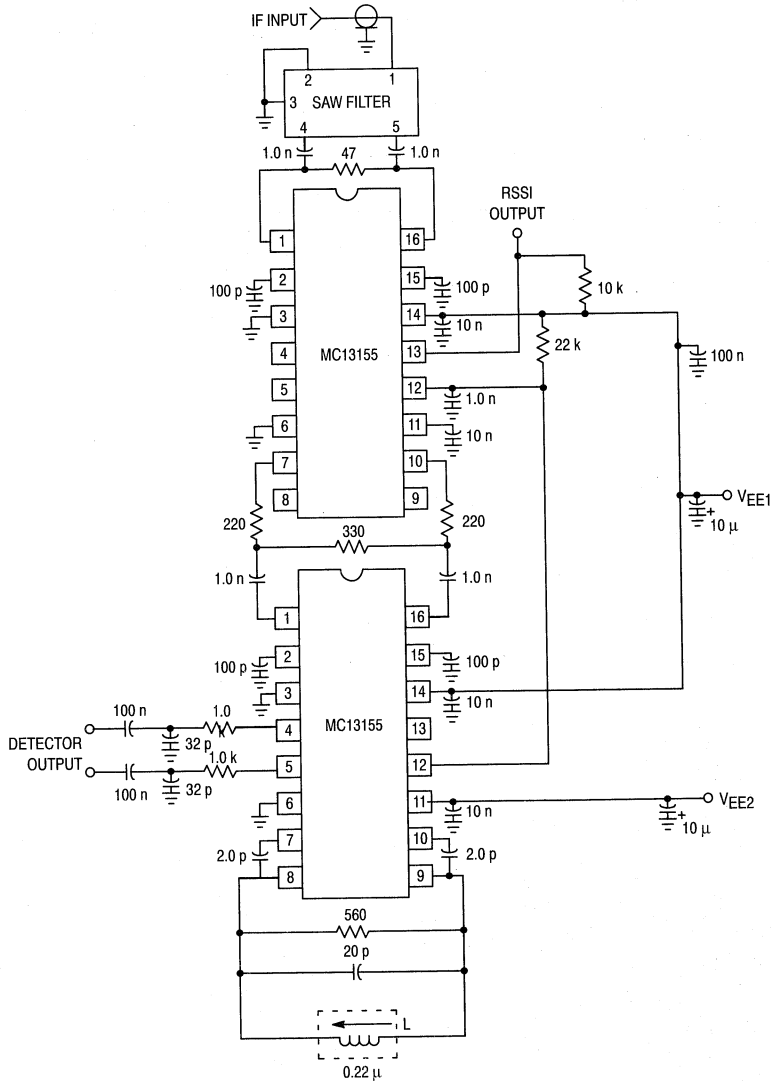

# Wideband FM IF System

## MC13156DW

$T_A = -40^\circ$  to  $+85^\circ\text{C}$ , Case 751E

The MC13156 is a wideband FM IF subsystem targeted at high performance data and analog applications. Excellent high frequency performance is achieved, with low cost, through use of Motorola's MOSAIC 1.5™ RF bipolar process. The MC13156 has an onboard Colpitts VCO for PLL controlled multichannel operation. The mixer is useful to beyond 200 MHz and may be used in a differential, balanced, or single-ended configuration. The IF amplifier is split to accommodate two low cost cascaded filters. RSSI output is derived by summing the output of both IF sections. A precision data shaper has a hold function to preset the shaper for fast recovery of new data.

Applications for the MC13156 include CT-2, wideband data links, and other radio systems utilizing GMSK, FSK or FM modulation.

- 2.0 to 6.0 Vdc Operation
- Typical Sensitivity of  $6.0\ \mu\text{V}$  for 12 dB SINAD
- RSSI Range of Greater than 70 dB
- High Performance Data Shaper for Enhanced CT-2 Operation
- Internal  $300\ \Omega$  and  $1.4\ \text{k}\Omega$  Terminations for 10.7 MHz and 455 kHz Filters
- Split IF for Improved Filtering and Extended RSSI Range

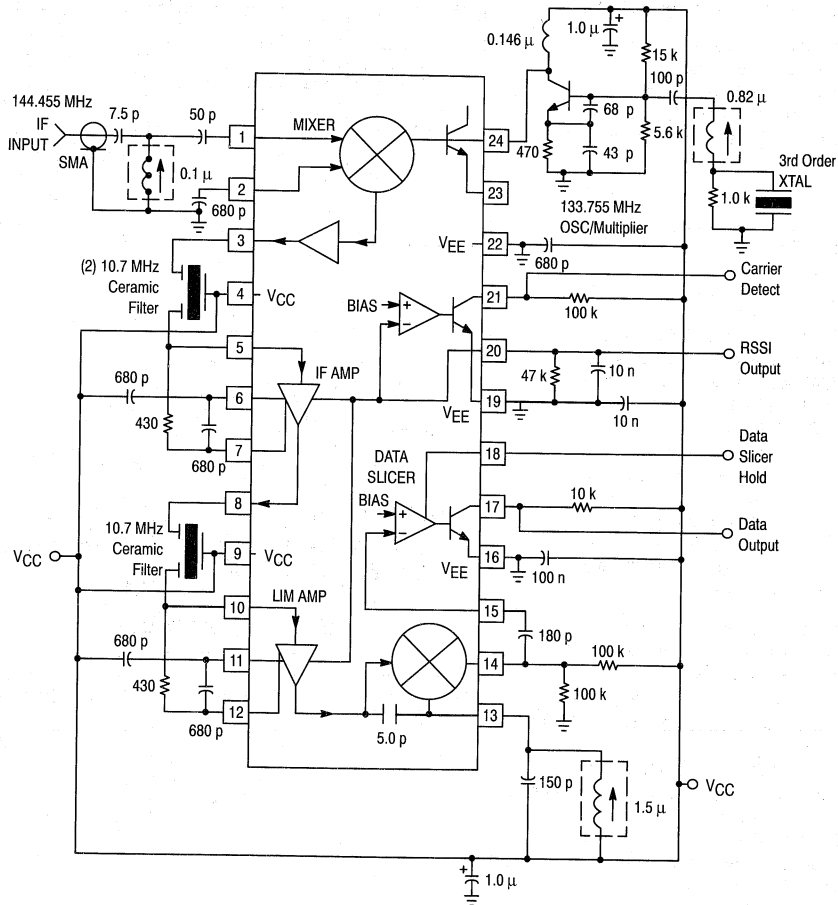

4

# Narrowband FM Receiver

## MC13135/136P, DW

$T_A = -40^\circ$  to  $+85^\circ\text{C}$ , Case 724, 751E

The MC13135 is a full dual conversion receiver with oscillators, mixers, Limiting IF Amplifier, Quadrature Discriminator, and RSSI circuitry. It is designed for use in security systems, cordless phones, and VHF mobile and portable radios. Its wide operating supply voltage range and low current make it ideal for battery applications. The Received Signal Strength Indicator (RSSI) has 65 dB of dynamic range with a voltage output, and an operational amplifier is included for a DC buffered output. Also, an improved mixer third order intercept enables the MC13135 to accommodate larger input signal levels.

- Complete Dual Conversion Circuitry
- Low Voltage: 2.0 to 6.0 Vdc
- RSSI with Op Amp: 65 dB Range
- Low Drain Current: 3.5 mA Typical
- Improved First and Second Mixer 3rd Order Intercept
- Detector Output Impedance: 25  $\Omega$  Typically

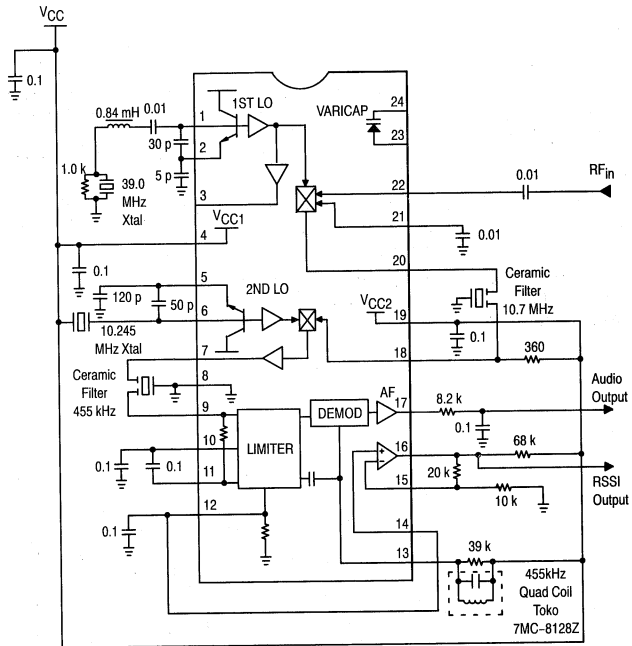

4

# UHF, FM/AM Transmitter

## MC13175/176D

$T_A = 0^\circ$  to  $+70^\circ\text{C}$ , Case 751B

The MC13175 and MC13176 are one chip FM/AM transmitter subsystems designed for AM/FM communication systems operating in the 260 to 470 MHz band covered by FCC Title 47; Part 15. They include a Colpitts crystal reference oscillator, UHF oscillator, +8 (MC13175) or +32 (MC13176) prescaler, and phase detector forming a versatile PLL system. Another application is as a local oscillator in a UHF or 900 MHz receiver. MC13175/176 offer the following features:

- UHF Current Controlled Oscillator
- Use Easily Available 3rd Overtone or Fundamental Crystals for Reference
- Low Number of External Parts Required
- Low Operating Supply Voltage (1.8–5.0 Vdc)
- Low Supply Drain Currents
- Power Output Adjustable (Up to +10 dBm)
- Differential Output for Loop Antenna or Balun Transformer Networks
- Power Down Feature
- ASK Modulated by Switching Output On and Off
- MC13175 —  $f_O = 8 \times f_{ref}$
- MC13176 —  $f_O = 32 \times f_{ref}$

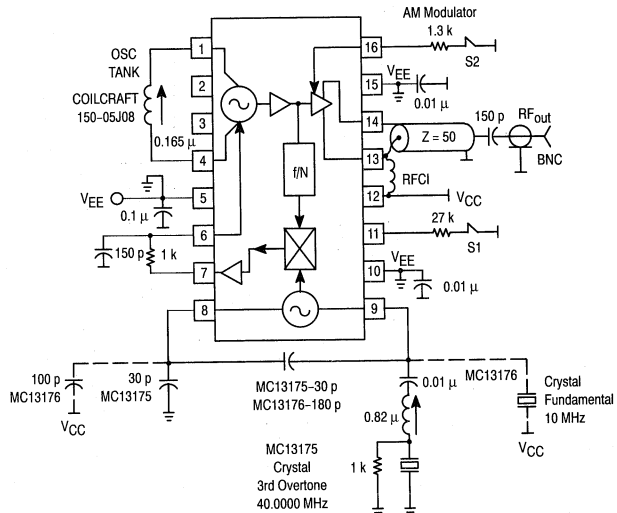

# Telecommunications

## Subscriber Loop Interface Circuits (SLIC)

### MC3419-1L

$T_A = 0^\circ$  to  $+70^\circ\text{C}$ , Case 726

The replacement of two-to-four wire conversion hybrid transformers in Central Office, PBX, and Subscriber Carrier equipment with the SLIC has resulted in major improvement in telephone equipment. The SLIC family performs this task, along with most other **BORSHT** functions required by signal transmission. These include the provision of DC power to the telephone (**B**attery); **O**vervoltage protection; **R**ing trip detection; **S**upervisory features such as hook status and dial pulsing; 2-to-4 wire conversion, suppression of longitudinal signals (**H**ybrid).

- All Key Parameters Externally Programmable
- Current Sensing Outputs Monitor Status of Both Tip and Ring Leads
- On-Hook Power Below 5.0 mW
- Digital Hook Status Output
- Power Down Input
- Ground Fault Protection
- Size and Weight Reduction Over Conventional Approaches
- The sale of this product is licensed under Patent No. 4,004,109. All royalties related to this patent are included in the unit price.

### MC33120/1P, FN

$T_A = -40^\circ$  to  $+85^\circ\text{C}$ , Case 738, 776

With a guaranteed minimum longitudinal balance of 58 dB, the MC33120/1 is ideally suited for Central Office applications, as well as PBXs, and other related equipment. Protection and sensing components on the two-wire side can be non-precision while achieving required system performance. Most BORSHT functions are provided while maintaining low power consumption, and a cost effective design. Size and weight reduction over conventional transformer designs permit a higher density system.

- All Key Parameters Externally Programmable with Resistors:
  - Transmit and Receive Gains
  - Transhybrid Loss
  - Return Loss
  - DC Loop Current Limit and Battery Feed Resistance
  - Longitudinal Impedance
- Single and Double Fault Sensing and Protection
- Minimum 58 dB Longitudinal Balance (2-wire and 4-wire) Guaranteed
- Digital Hook Status and Fault Outputs
- Power Down Input
- Loop Start or Ground Start Operation
- Size & Weight Reduction Over Conventional Approaches
- Available in 20 Pin DIP and 28 Pin PLCC Packages
- Battery Voltage:  $-42$  to  $-58$  V (for MC33120),  $-21.6$  to  $-42$  V (for MC33121)

4

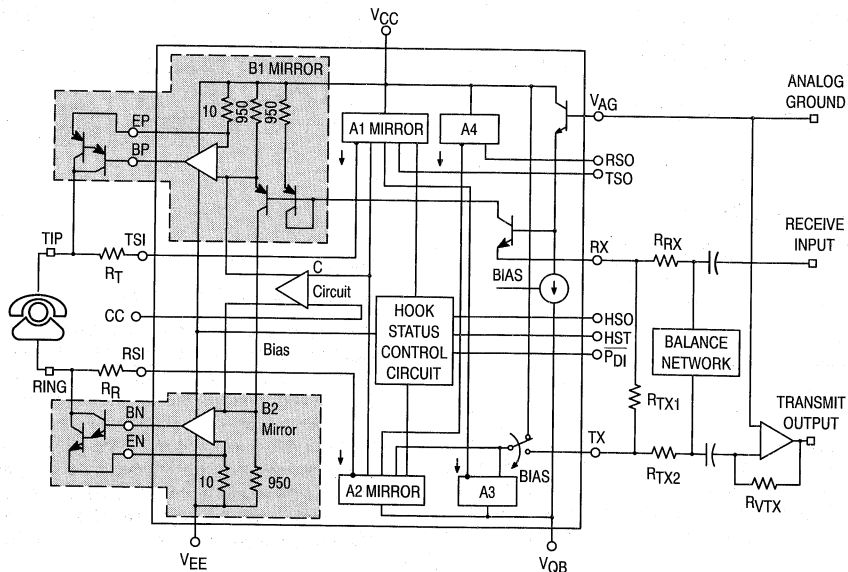

## Subscriber Loop Interface Circuits (SLIC) (continued)

### MC33122

$T_A = -40^\circ$  to  $+85^\circ\text{C}$ , Case \*TBD

The MC33122 is designed to provide the interface between the four-wire side of a Central Office or remote terminal and the two-wire subscriber line. Interface functions include battery feed, proper loop termination AC impedance, adjustable transmit, receive and transhybrid gains, hookswitch and ring trip detection. Additionally, the MC33122 provides a minimum of 58 dB of longitudinal balance.

The transmit and receive signals are referenced to analog ground (VAG), easing the interface to Codecs, filters, etc. The logic interface is TTL and CMOS compatible.

Internal loop current power transistors sink and source current at tip and ring. Thermal shutdown is provided to protect against line faults. A switching regulator is used to reduce power dissipation and enhance reliability, and a clock input allows synchronization to minimize noise.

The MC33122 will be fabricated on a standard high voltage (90 V) BIMOS process to increase protection during lightning surges. It will be available in a 52 pin PLCC and 64 pin QFP package.

4

- Designed in Accordance with TR-000057 and TA-000909 Bellcore Objectives
- Suitable for CO, Digital Loop Carrier Systems (DLCS), and PBX
- Full On-Hook Transmission Capability
- On-Chip Loop Current Power Transistors
- Reduced Power Dissipation with Switching Regulator
- Minimum 58 dB Longitudinal Balance
- Externally Adjustable Impedance, Tx, Rx and Transhybrid Gains
- Current Limit Externally Adjustable to 50 mA
- Hook Switch Detection and Ring Tip Capability, Adjustable
- Polarity Reversal and Power Down Capability
- Ground Start Sequence Controls
- Two Relay Drivers

## PBX Architecture (Analog Transmission)

## PCM Mono-Circuits Codec-Filters (CMOS LSI)

### MC145500 Series

Case 620, 648, 708, 726, 736, 751, 776

The Mono-circuits perform the digitizing and restoration of the analog signals. In addition to these important functions, Motorola's family of pulse-code modulation mono-circuits also provides the band-limiting filter functions — all on a single monolithic CMOS chip with extremely low power dissipation.

The Mono-circuits require no external components. They incorporate the bandpass filter required for antialiasing and 60 Hz rejection, the A/D-D/A conversion functions for either U.S. Mu-Law or European A-Law companding formats, the low-pass filter required for reconstruction smoothing, an on-board precision voltage reference, and a variety of options that lend flexibility to circuit implementations. Unique features of Motorola's Mono-circuit family include wide power supply range (6 to 13 V) selectable on-board voltage reference (2.5, 3.1, or 3.8 V), and TTL or CMOS I/O interface.

Motorola supplies five versions in this series. The MC145500, MC145503 and MC145505 are general-purpose devices in 16 pin packages designed to operate in digital telephone or line card applications. The MC145501 is the same device (in an 18 pin package) that offers the capability of selecting from three peak overload voltages (2.5, 3.15 and 3.78 V). The MC145502 is the full-feature device that presents all of the options available on the chip. This device is packaged in a 22 pin DIP and 28 pin chip carrier package.

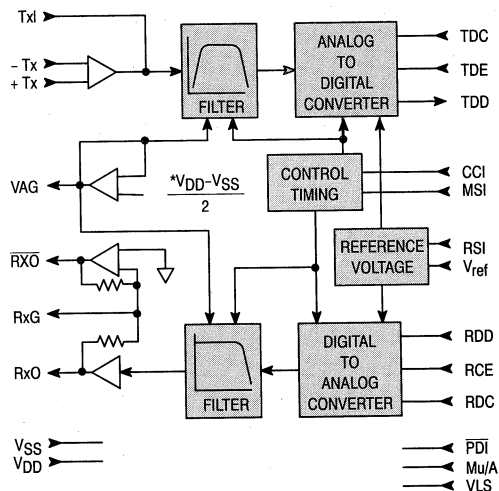

### MC145554/57/64/67

Case 620, 648, 732, 738, 751D, 751G

These per channel PCM Codec-filters perform the voice digitization and reconstruction as well as the band limiting and smoothing required for PCM systems. They are designed to operate in both synchronous and asynchronous applications and contain an on-chip precision voltage reference. The MC145554 (Mu-Law) and MC145557 (A-Law) are general purpose devices that are offered in 16 pin packages. The MC145564 (Mu-Law) and MC145567 (A-Law), offered in 20 pin packages, add the capability of analog loop-back and push-pull power amplifiers with adjustable gain.

## PBX Architecture (continued)

All four devices include the transmit bandpass and receive lowpass filters on-chip, as well as active RC pre-filtering and post-filtering. Fully differential analog circuit design assures lowest noise. Performance is specified over the extended temperature range of  $-40^{\circ}$  to  $+85^{\circ}\text{C}$ .

These PCM Codec-filters accept both industry standard clock formats. They also maintain compatibility with Motorola's family of MC3419/MC33120 SLIC products.

### MC145480

Case 738, 751D

This 5.0 V, general purpose per channel PCM Codec-filter offers selectable Mu-Law or A-Law companding in 20 pin DIP and SOG packages. It performs the voice digitization and reconstruction as well as the band limiting and smoothing required for PCM systems. It is designed to operate in both synchronous and asynchronous applications and contains an on-chip precision reference voltage (1.575 V).

The transmit bandpass and receive lowpass filters, and the active RC pre-filtering and post-filtering are incorporated, as well as fully differential analog circuit design for lowest noise. Push-pull 300  $\Omega$  power drivers with external gain adjust are also included.

The MC145480 PCM Codec-filter accepts a variety of clock formats, including short-frame sync, long-frame sync, IDL, and GCI timing environments. This device also maintains

compatibility with Motorola's family of Telecom products, including the MC145472 U Interface Transceiver, MC145474/75 S/T Interface Transceiver, MC145532 ADPCM Transceiver, MC145422/26 UDLT-I, MC145421/25 UDLT-II, and MC3419/MC33120 SLIC.

### MC145540

Case 710, 751F

The MC145540 ADPCM Codec is a single chip implementation of a PCM codec-filter and an ADPCM encoder/decoder, and therefore provides an efficient solution for applications requiring the digitization and compression of voiceband signals. This device is designed to operate over a wide voltage range, 2.7 V to 5.25 V, and as such is ideal for battery powered as well as AC powered applications. The MC145540 ADPCM Codec also includes a serial control port and internal control and status registers that permit a microcomputer to exercise many built-in features.

The ADPCM Codec is designed to meet the 32 kbps ADPCM conformance requirements of CCITT Recommendation G.721 and ANSI T1.301. It also meets ANSI T1.303 and CCITT Recommendation G.723 for 24 kbps ADPCM operation, and the 16 kbps ADPCM standard, CCITT Recommendation G.726. This device also meets the PCM conformance specification of the CCITT G.714 Recommendation.

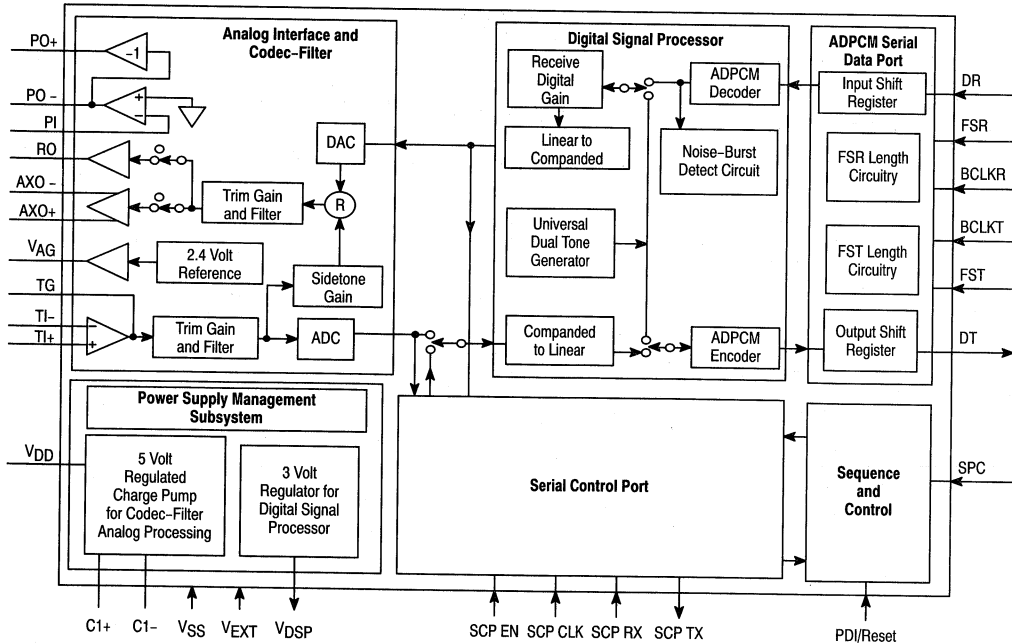

Figure 21. MC145540 ADPCM Codec Block Diagram

4



## PBX Architecture (continued)

### MC145537EVK ADPCM Codec Evaluation Kit

The MC145537EVK is the primary tool for evaluation and demonstration of the MC145540 ADPCM Codec. It provides the necessary hardware and software interface to access the many features and operational modes of the MC145540 ADPCM Codec.

- Provides Stand Alone Evaluation on Single Board
- The kit provides Analog-to-Analog, Analog-to-Digital or Digital-to-Analog Connections — with Digital Connections being 64 kbps PCM, 32 or 24 kbps ADPCM, or 16 kbps CCITT G.726 or Motorola Proprietary ADPCM
- +5.0 V Only Power Supply, or 5.0 V Plus 2.7 to 5.25 V Supply
- Easily Interfaced to Test Equipment, Customer System, Second MC145537EVK or MC145536EVK (5.0 V Only) for Full Duplex Operation

- Convenient Access to Key Signals
- Piezo Loudspeaker
- EIA-232 Serial Computer Terminal Interface for Control of the MC145540 ADPCM Codec Features
- Compatible Handset Provided
- Schematics, Data Sheets, and User's Manual Included

#### Also Available — Filters:

##### MC145414

Dual Tuneable Low-Pass Sampled Data Filter

##### MC145432

2600 Hz Tone Signalling Filter

4

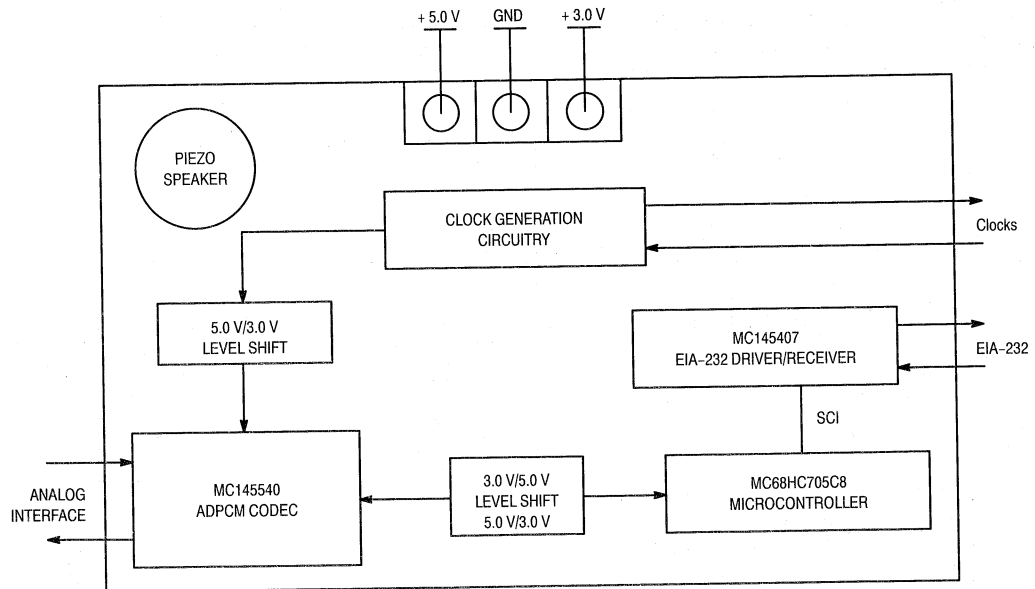

Figure 22. MC145537EVK Block Diagram

## PBX Architecture (continued)

### MC145536EVK

Codec-Filter/ADPCM Transcoder Evaluation Kit

The MC145536EVK is the primary tool for evaluation and demonstration of the MC145480 Single +5.0 V supply PCM Codec-Filter and the MC145532 ADPCM Transcoder (see "Telephone Accessory Circuits"). The MC145536EVK provides the necessary hardware needed to evaluate the many separate operating modes under which the MC145480 and MC145532 are intended to operate.

- Provides Stand Alone Evaluation on a Single Board
- Easily Interfaced to Test Equipment, Customer System, or Second MC145536EVK
- Convenient Access to Key Signals
- Generous Wire-Wrap Area for Application Development
- The kit provides Analog-to-Analog, Analog-to-Digital, or Digital-to-Analog Connections - with Digital Connections Being 64 kbps PCM; 32, 24, or 16 kbps Motorola Proprietary ADPCM
- Compatible Handset Included
- Schematics, Data Sheets, and User's Manual included

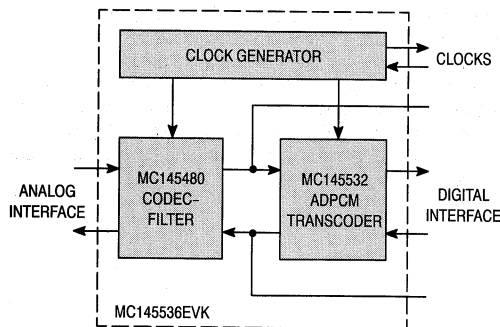

## Dual Tone Multiple Frequency Receiver

### MC145436

Case 646, 751

This device contains the filter and decoder for detection of a pair of tones conforming to the DTMF standard with outputs in hexadecimal. Switched capacitor filter technology is used together with digital circuitry for the timing control and output circuits. The MC145436 provides excellent power-line noise and dial tone rejection.

## Crosspoint Switches

Crosspoint switches implemented with semiconductor technology take the place of the huge banks of mechanical relay matrices once utilized in Central Offices and PBXs.

Motorola's crosspoint switches have latches to control the state of any particular switch in order to route analog or digital signals. These ICs find applications in PBXs, key systems, and test equipment.

Table 49.

Device	Description	Suffix/Package
MC142100	4 × 4 × 1 Analog Switch <ul style="list-style-type: none"> <li>• 4.2 to 18 V Operation</li> <li>• Low On-State Resistance</li> </ul>	CL/620 CP/648 DW/751G
MC145100	4 × 4 × 1 Analog Switch <ul style="list-style-type: none"> <li>• 4.2 to 18 V Operation</li> <li>• Low On-State Resistance</li> <li>• Power-On Reset</li> </ul>	CP/648

## ISDN Voice/Data Circuits

### Integrated Services Digital Network

ISDN is the revolutionary concept of converting the present analog telephone networks to an end-to-end global digital network. ISDN standards make possible a wide variety of services and capabilities that are revolutionizing communications in virtually every industry.

Motorola's ISDN product family includes the MC145472 U-Interface Transceiver, the MC145474/75 S/T-Interface Transceivers, MC145488 Dual Data Link Controller, and the MC68302 Integrated Multi-Protocol Processor. These are supported by a host of related devices including the MC145480 +5.0 V PCM Codec-Filter, MC145532 ADPCM Transcoder, MC145540 ADPCM Codec, MC145500 family of single-chip codec/filters, MC145436 DTMF Decoder, MC33120 Subscriber Loop Interface Circuit, MC34129 Switching Power Supply Controller, MC145611 PCM Conference Circuit, and the MC145406/07 CMOS EIA 232-D Driver/ Receiver family.

Motorola's key ISDN devices fit into four ISDN network applications: a digital subscriber line card, an NT1 network termination, an ISDN terminal adapter, and an ISDN terminal. Digital subscriber line cards are used in central offices, remote concentrators, channel banks, T1 multiplexers, and other switching equipment. The NT1 network termination block illustrates the simplicity of remote U to S/T-interface conversion. The ISDN terminal adapter and ISDN terminal block show how Motorola ICs are used to combine voice and data in PC compatible boards, digital telephones, and other terminal equipment. Expanded applications such as a PBX may include these and other Motorola ISDN circuits. Many "non-ISDN" uses, such as pairgain applications, are appropriate for Motorola's ISDN devices as well.

4

**ISDN Voice/Data Circuits (continued)**

**U-Interface Transceivers**

**MC145472**

Case 847B

**MC14LC5472**

Case 847B, 847

The MC145472/MC14LC5472 fully conforms to ANSI T1.601-1991, the North American standard for ISDN Basic Access on a single twisted-wire pair. The transceiver achieves a remarkable  $10^{-7}$  bit error rate performance on all ANSI specified test loops with worst-case impairments present. The state-of-the-art 1.2 micron single-chip solution uses advanced design techniques to combine precision analog signal processing elements with three digital signal coprocessors to build an adaptively equalized echo cancelling receiver.

Two modes of handling U-interface maintenance functions are provided on the MC145472/MC14LC5472. In the automatic maintenance mode the U-interface transceiver handles all ANSI specified maintenance and channel procedures internally to minimize your software development effort. Automatic procedures include generating and monitoring the cyclic redundancy check, reporting and counting far end block errors (near end block errors too), handling the ACT and DEA bits, as well as monitoring and appropriately responding to embedded operations channel messages.

The optional manual maintenance mode lets you choose an inexpensive microcontroller, such as a member of

Motorola's MC68HC05 family, to control and augment the standard maintenance channel functions. This flexible feature also allows for easy implementation of proprietary maintenance functions.

**S/T-Interface Transceivers**

**MC145474**

Case 736A

**MC145475**

Case 710, 751F

The MC145474/75 S/T-Interface Transceivers provide a CCITT 1.430 compatible interface for use in line card, network termination, and ISDN terminal equipment applications. Manufactured with Motorola's advanced 1.5 micron CMOS mixed analog and digital process technology, the MC145474/75 is a physical layer device capable of operating in point-to-point or point-to-multipoint passive bus arrangements. In addition, the MC145475 can implement the optional NT1 Star topology.

This device features outstanding transmission performance. It reliably transmits over 2.5 kilometers in a point-to-point application with specifications of 1 kilometer. Comparable performance is achieved in all other topologies as well. Other features include pin selectable terminal or network operating modes, industry standard microprocessor serial control port, full support of the multiframing S and Q channels, a full range of loopbacks, and low power CMOS operation.

**4**

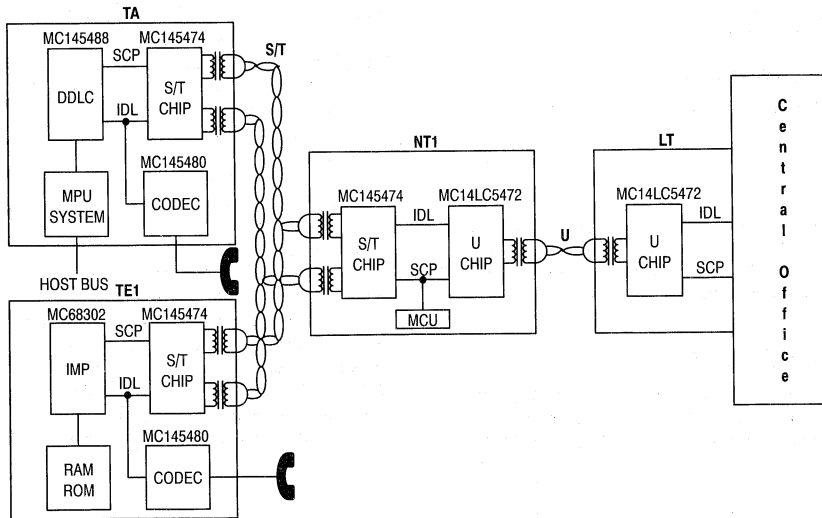

## ISDN Voice/Data Circuits (continued)

### Dual Data Link Controller

#### MC145488

Case 779

The MC145488 features two full-duplex serial HDLC channels with an on-chip Direct Memory Access (DMA) controller. The DMA controller minimizes the number of microprocessor interrupts from the communications channels, freeing the microprocessor's resources for other tasks. The DMA controller can access up to 64 kbytes of memory, and transfers either 8-bit bytes or 16-bit words to or from memory. The MC145488 DDLC is compatible with Motorola's MC68000 and other microprocessors.

In a typical ISDN terminal application, one DDLC communications channel supports the D-channel (LAPD) while the other supports the B-channel (LAPB). While the DDLC is ideally suited for ISDN applications, it can support many other HDLC protocol applications as well.

Some of the powerful extras found on the DDLC include automatic abort and retransmit of D-channel collisions in S/T-interface applications, address recognition, automatic recovery mechanisms for faulty frame correction, and several system test modes. Address recognition provides a reduction in the host microprocessor load by filtering data frames not addressed to the host. The DDLC can compare either SAPI or TEI fields of LAPD frames. For LAPD (Q.921) applications, both A and B addresses may be checked.

#### MC14LC5494EVK

U-Interface Transceiver Evaluation Kit

This kit provides the hardware and software to evaluate the many configurations under which the MC14LC5472 is able to operate. Used as a whole, it operates as both ends of the two-wire U interface that extends from the customer premises (NT1) to the switch line card (LT). The two halves of the board can be physically and functionally separated, providing independent NT1 and LT evaluation capability.

The kit provides the ability to interactively manipulate status registers in the MC14LC5472 U-Interface transceiver or in the MC145474/75 S/T-Interface transceiver with the aid of an external terminal. The device can also be controlled using the MC68302 Integrated Multiprotocol Processor application development system to complete a total Basic Rate ISDN evaluation solution.

A generous wire-wrap area is available to assist application development.

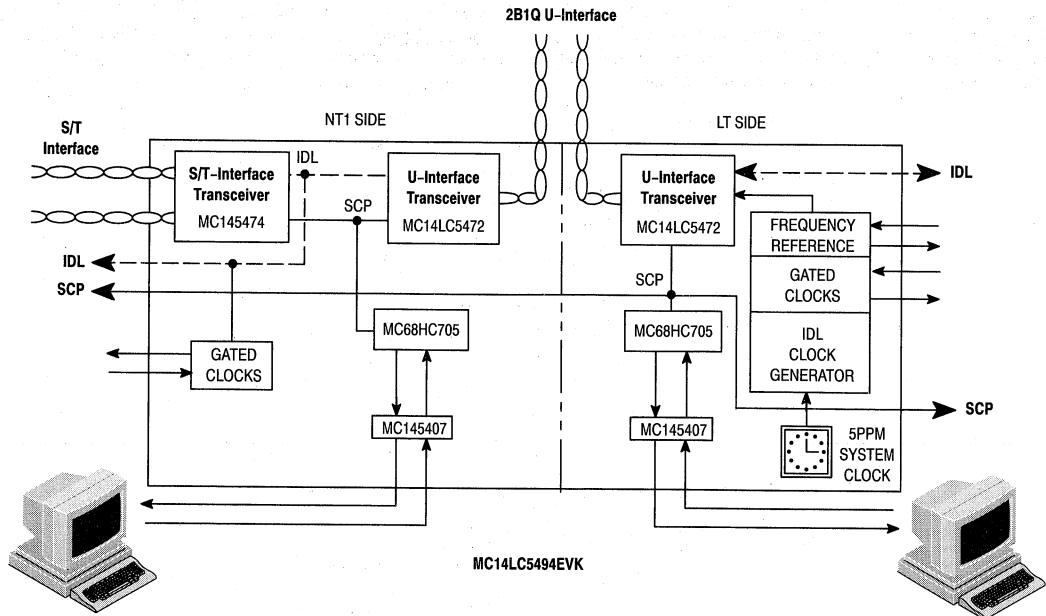

4

# Voice/Data Communication (Digital Transmission)

## 2-Wire Universal Digital Loop Transceiver (UDLT)

**MC145422 Master Station**  
Case 708, 736, 751E

**MC145426 Slave Station**  
Case 708, 736, 751E

The UDLT family of transceivers allows the use of existing twisted-pair telephone lines (between conventional telephones and a PBX) for the transmission of digital data. With the UDLT, every voice-only telephone station in a PBX system can be upgraded to a digital telephone station that handles the complex voice/data communications with no increase in cabling costs.

In implementing a UDLT-based system the A/D to D/A conversion function associated with each telset is relocated from the PBX directly to the telset. The SLIC (or its equivalent circuit) is eliminated since its signaling information is transmitted digitally between two UDLTs.

The UDLT master-slave system incorporates the modulation/demodulation functions that permit data communications over a distance up to 2 kilometers. It also provides the sequence control that governs the exchange of information between master and slave. Specifically, the master resides on the PBX line card where it transmits and receives data over the wire pair to the telset. The slave is located in the telset and interfaces the mono-circuit to the wire pair. Data transfer occurs in 10-bit bursts (8 bits of data and 2 signaling bits), with the master transmitting first, and the slave responding in a synchronized half-duplex transmission format.

4

UDLTs utilize a 256 kilobaud Modified Differential Phase Shift Keyed (MDPSK) burst modulation technique for transmission to minimize radio frequency, electromagnetic, and crosstalk interference. Implementation through CMOS technology takes advantage of low-power operation, increased reliability, and the proven capabilities to perform complex telecommunications functions.

### Functional Features

- Provides Synchronous Duplex 64 kbits/Second Voice/Data Channel and Two 8 kbits/Second Signaling Data Channels Over One 26 AWG Wire Pair Up to 2 km.
- Compatible with Existing and Evolving Telephone Switch Architectures and Call Signaling Schemes
- Automatic Detection Threshold Adjustment for Optimum Performance Over Varying Signal Attenuations
- Protocol Independent
- Single 5.0 V to 8.0 V Power Supply

### MC145422 Master UDLT

- 2.048 MHz Master Clock
- Pin Controlled Power-Down and Loop-Back Features
- Variable Data Clock — 64 kHz to 2.56 MHz
- Pin Controlled Insertion/Extraction of 8 kbits/Seconds Channel into LSB of 64 kbits/Second Channel for Simultaneous Routing of Voice and Data Through PCM Voice Path of Telephone Switch

### MC145426 Slave UDLT

- Compatible with MC145500 Series and Later PCM Mono-Circuits
- Automatic Power-Up/Down Feature
- On-Chip Data Clock Recovery and Generation
- Pin Controlled 500 Hz D3 or CCITT Format PCM Tone Generator for Audible Feedback Applications

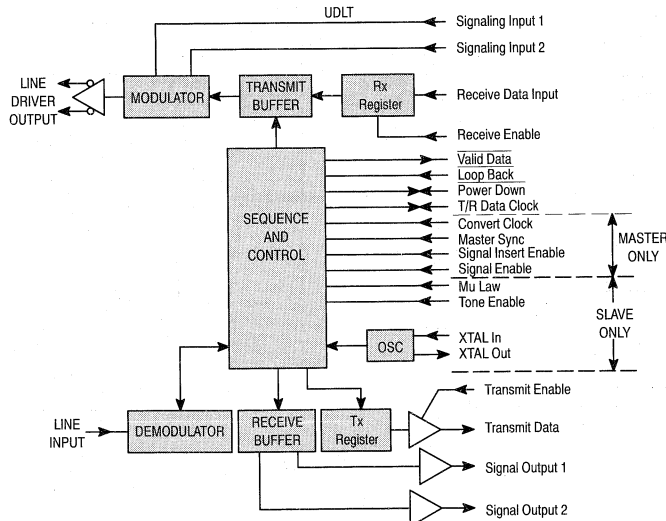

## Voice/Data Communication (Digital Transmission) (continued)

### 2-Wire ISDN Universal Digital Loop Transceiver II (UDLT II)

#### MC145421 Master

Case 623, 709, 751E2

#### MC145425 Slave

Case 623, 709, 751E

Similar to the MC145422/26 UDLT, but provide 160 kbps in two 64 kbps and two 16 kbps (2B + 2D) format.

### Data Set Interface Circuit (DSI)

#### MC145428

T<sub>A</sub> = -40° to + 85°C, Case 738, 751D

This new CMOS LSI circuit provides asynchronous-to-synchronous data conversion. It is particularly well-suited for use in conjunction with a UDLT-based integrated voice/data system. The MC145428 DSI provides EIA-232-to-time slot data conversion that permits direct interface between existing data equipment and the UDLT without modifications. With this interactive component, digitized voice information from the PCM Mono-Circuit and asynchronous data from computers or terminals can be transmitted simultaneously through a synchronous switching network.

DSI circuits are also suited for data multiplexers, concentrators and deconcentrators, data rate changers, data-only switching, and PBX-based local area networks.

#### MC145428 Features

- Up to 128 kbps asynchronous data rate operation
- 0 up to 2.1 Mbps synchronous data rate operation
- On-board bit rate clock generator with pin selectable bit rates of 300, 1200, 2400, 4800, 9600, 19200, and 38400 bps or an externally supplied 16 times bit rate clock may be used
- Accepts asynchronous data words of 8 or 9 bits
- False start detection provided
- Automatic sync insertion and checking

4

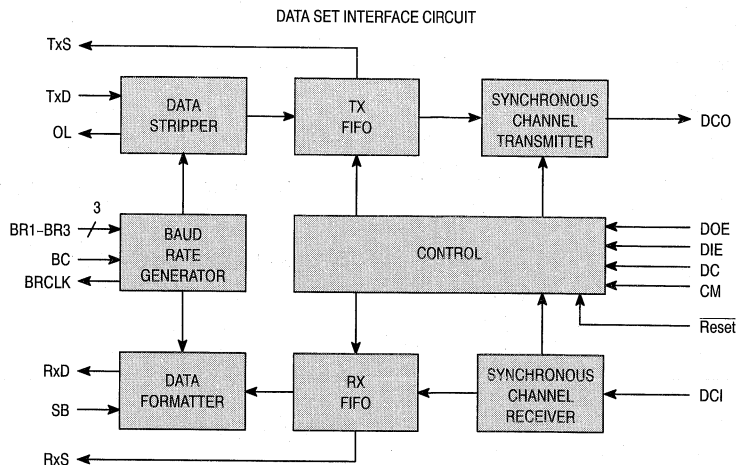

# Electronic Telephone

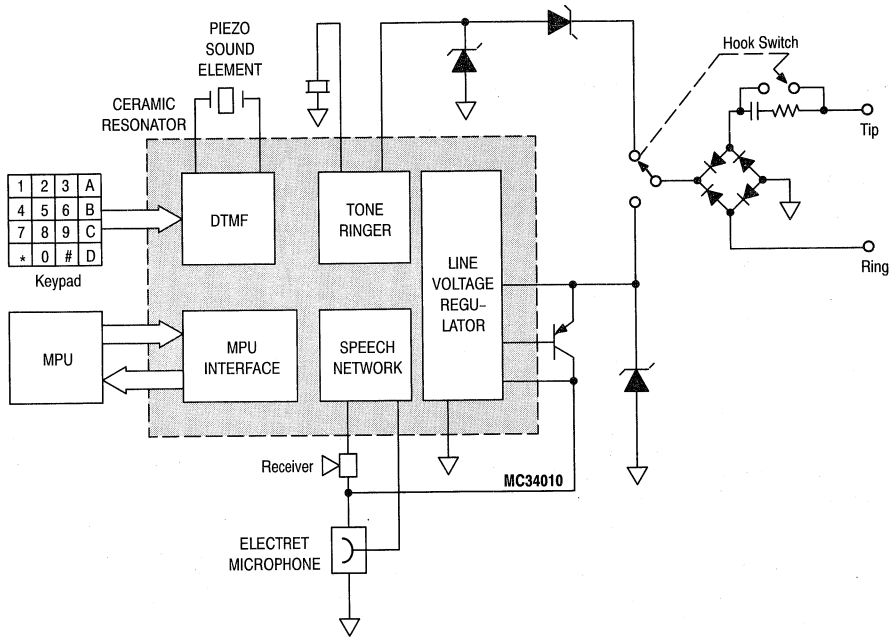

4

## The Complete Electronic Telephone Circuit

MC34010P, FN

$T_A = -20^\circ$  to  $+60^\circ\text{C}$ , Case 711, 777

The conventional transformer-driven telephone handset is undergoing major innovations. The bulky transformer is disappearing. So are many of its discrete components, including the familiar telephone bell. They are being replaced with integrated circuits that perform all the major handset functions simply, reliably and inexpensively . . . functions such as 2-to-4 wire conversion, DTMF dialing, tone ringing, and a variety of related activities.

The culmination of these capabilities is the Electronic Telephone Circuit, the MC34010. These ICs place all of the above mentioned functions on a single monolithic chip.

These telephone circuits utilize advanced bipolar linear ( $I^2L$ ) technology and provide all the necessary elements of a modern tone-dialing telephone. The MC34010 even incorporates an MPU interface circuit for the inclusion of automatic dialing in the final system.

- Provides all basic telephone functions, including DTMF dialer, tone ringer, speech network and line voltage regulator
- DTMF generator uses low cost ceramic resonator with accurate frequency synthesis technique

- Tone ringer drives piezoelectric transducer and satisfies EIA-470 requirements
- Speech network provides 2-to-4 wire conversion with adjustable sidetone utilizing an electret transmitter
- On-chip regulator insures stable operation over wide range of loop lengths
- $I^2L$  technology provides low 1.4 V operation and high static discharge immunity
- Microprocessor interface port for automatic dialing features

### Also Available

A broad line of additional telephone components for customizing systems design.

## Audio Control Circuit

MC145429

Telset audio interface circuit for MPU-controlled independent adjustment of ear piece, speaker and ringer volume.

## Dial Circuits

MC145412/13/16

Integrated Tone/Pulse 10-number Repertory Dialer

MC145512/13

Integrated Tone/Pulse 10-number Repertory Dialer

# Tone Ringers

The MC34012, MC34017, and MC34117 Tone Ringers are designed to replace the bulky bell assembly of a telephone, while providing the same function and performance under a variety of conditions. The operational requirements spelled out by the FCC and EIA-470, simply stated, are that a ringer

circuit MUST function when a ringing signal is provided, and MUST NOT ring when other signals (speech, dialing, noise) are on the line. The tone ringers described below were designed to meet those requirements with a minimum of external components.

## MC34012P, D

$T_A = -20^\circ$  to  $+60^\circ\text{C}$ , Case 626, 751

- Complete Telephone Bell Replacement
- On-Chip Diode Bridge and Transient Protection
- Single-Ended Output to Piezo Transducer
- Input Impedance Signature Meets Bell and EIA Standards
- Rejects Rotary Dial and Hook Switch Transients
- Adjustable Base Frequencies
- Output Frequency to Warble Ratio —  
 MC34012-1:80  
 MC34012-2:160  
 MC34012-3:40

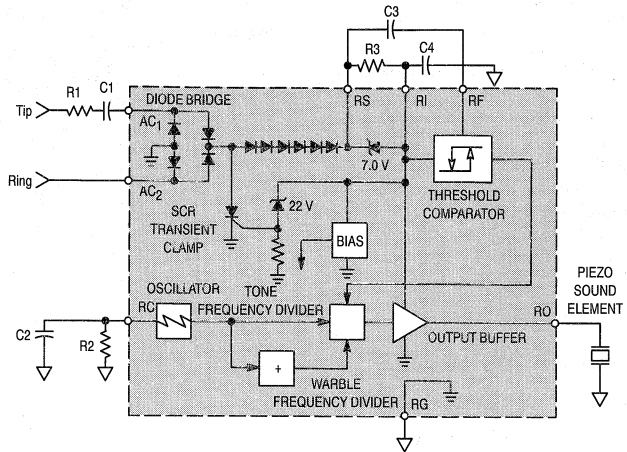

4

## MC34017P, D

$T_A = -20^\circ$  to  $+60^\circ\text{C}$ , Case 626, 751

- Complete Telephone Bell Replacement
- On-Chip Diode Bridge and Transient Protection
- Differential Output to Piezo Transducer for Louder Sound
- Input Impedance Signature Meets Bell and EIA Standards
- Rejects Rotary Dial and Hook Switch Transients
- Output Frequency to Warble Ratio —  
 MC34017-1:80  
 MC34017-2:160  
 MC34017-3:40

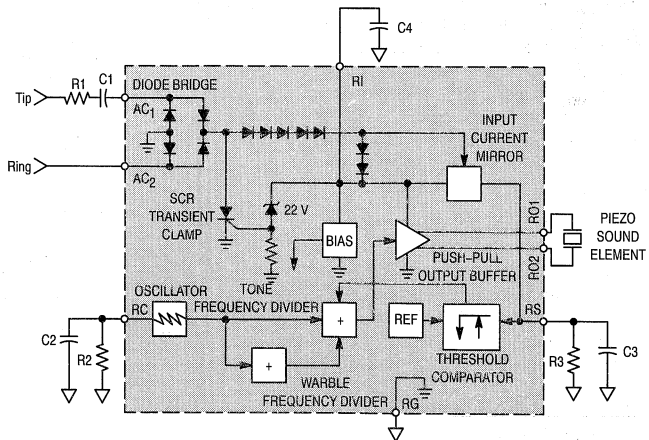



## Tone Ringers (continued)

### MC34217P, D

$T_A = -20^\circ$  to  $+60^\circ\text{C}$ , Case 626, 751

- Complete Telephone Bell Replacement
- On-Chip Diode Bridge
- Internal Transient Protection
- Differential Output to Piezo Transducer for Louder Sound
- Input Impedance Signature Meets Bell and EIA Standards
- Rejects Rotary Dial and Hook Switch Transients
- Base Frequency and Warble Frequencies are Independently Adjustable
- Adjustable Base Frequency
- Reduced Number of Externals

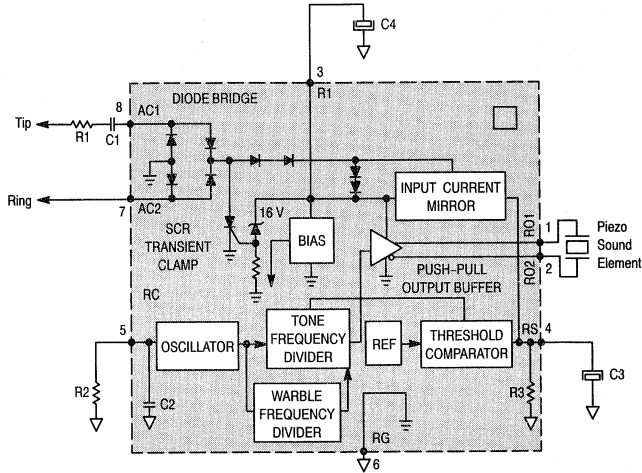

## Speech Networks

### Speech Network with Dialer Interface

### MC34014P, DW

$T_A = -20^\circ$  to  $+60^\circ\text{C}$ , Case 707, 751D

The MC34014 is a Telephone Speech Network integrated circuit which incorporates adjustable transmit, receive, and sidetone functions, line interface circuit, dialer interface, and a regulated output voltage for a dialer circuit. It includes an equalization circuit to compensate for various line lengths and the conversion from 2-to-4 wire is accomplished with supply voltages as low as 1.5 V.

- Transmit, Receive, and Sidetone Gains Set by External Resistors
- Loop Length Equalization for Transmit, Receive, and Sidetone Functions
- Operates Down to 1.5 V ( $V_+$ ) in Speech Mode
- Provides Regulated Voltage for CMOS Dialer
- Speech Amplifiers Muted During Pulse and Tone Dialing
- DTMF Output Level Adjustable with a Single Resistor
- Compatible with 2-Terminal Electret Microphones
- Operates with Receiver Impedances of 150  $\Omega$  and Higher

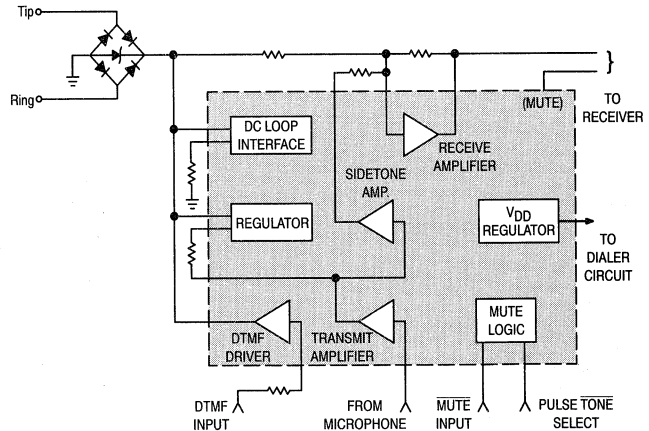

## Speech Networks (continued)

### Telephone Speech Network with Dialer Interface

#### MC34114P, DW

$T_A = -20^\circ$  to  $+70^\circ\text{C}$ , Case 707, 751D

- Operation Down to 1.2 V
- Adjustable Transmit, Receive, and Sidetone Gains by External Resistors
- Differential Microphone Amplifier Input Minimizes RFI
- Transmit, Receive, and Sidetone Equalization on both Voice and DTMF Signals

- Regulated 1.7 V Output for Biasing Microphone
- Regulated 3.3 V Output for Powering External Dialer
- Microphone and Receive Amplifiers Muted During Dialing
- Differential Receive Amplifier Output Eliminates Coupling Capacitor
- Operates with Receiver Impedances of 150  $\Omega$  and Higher

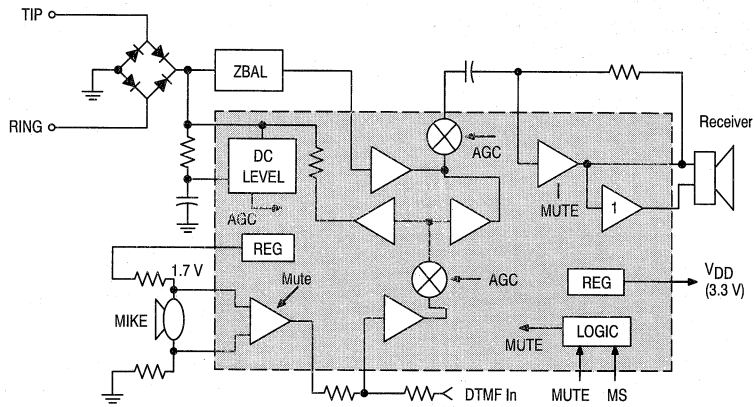

4

# Speakerphone

## Voice Switched Speakerphone Circuit

### MC34018P, DW

$T_A = -20^\circ$  to  $+60^\circ\text{C}$ , Case 710, 751F

The MC34018 Speakerphone integrated circuit incorporates the necessary amplifiers, attenuators, and control functions to produce a high quality hands-free speakerphone system. Included are a microphone amplifier, a power audio amplifier for the speaker, transmit and receive attenuators, a monitoring system for background sound level, and an attenuation control system which responds to the relative transmit and receive levels as well as the background level. Also included are all necessary regulated voltages for both internal and external circuitry, allowing line-powered operation (no additional power supplies required). A Chip Select pin allows the chip to be powered down when not in use. A volume control function may be implemented with an external potentiometer. MC34018 applications include speakerphones for household and business uses, intercom systems, automotive telephones, and others.

- All Necessary Level Detection and Attenuation Controls for a Hands-Free Telephone in a Single Integrated Circuit
- Background Noise Level Monitoring with Long Time Constant
- Wide Operating Dynamic Range Through Signal Compression
- On-Chip Supply and Reference Voltage Regulation
- Typical 100 mW Output Power (into 25  $\Omega$ ) with Peak Limiting to Minimize Distortion
- Chip Select Pin for Active/Standby Operation
- Linear Volume Control Function

4

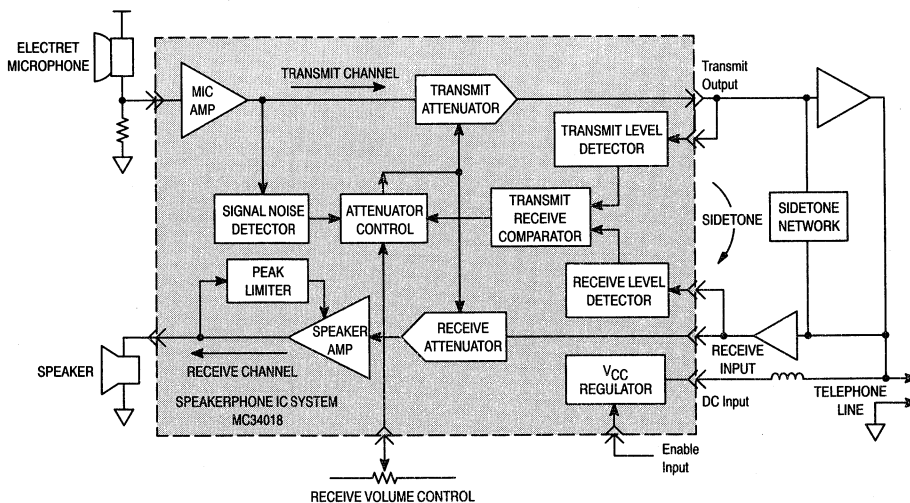

## Speakerphone (continued)

### Voice Switched Speakerphone with $\mu$ Processor Interface

#### MC33218P, DW

$T_A = -40^\circ$  to  $+85^\circ\text{C}$ , Case 724, 751E

The MC33218 Voice Switched Speakerphone circuit incorporates the necessary amplifiers, attenuators, level detectors, and control algorithm to form the heart of a high quality hands-free speakerphone system. Included are a microphone amplifier with adjustable gain, and mute control, transmit and receive attenuators which operate in a complementary manner, and level detectors and background noise monitors for both paths. A dial tone detector prevents dial tone from being attenuated by the receive background noise monitor. A Chip Disable pin permits powering down the entire circuit to conserve power.

Also included is an 8-bit serial  $\mu$ processor port for controlling the receive volume, microphone mute, attenuator gain, and operation mode (force to transmit, force to receive, etc.). Data rate can be up to 1.0 MHz. The MC33218 can be operated from a power supply, or from the telephone line, requiring typically 3.8 mA. It can also be used in intercoms and other voice-activated applications.

- Low Voltage Operation: 2.5 to 6.0 V
- 2-Point Sensing, Background Noise Monitor in Each Path
- Chip Disable Pin for Active/Standby Operation
- Microphone Amplifier Gain Set by External Resistors — Mute Function Included
- Dial Tone Detector to Inhibit Receive Idle Mode During Dial Tone Presence
- Microprocessor port for controlling:
  - Receive Volume Level (16 Steps)
  - Attenuator Range (26 or 52 dB, Selectable)
  - Microphone Mute
  - Force to Transmit, Receive, Idle or Normal Voice Switched Operation
- Compatible with MC34119 Speaker Amplifier

4

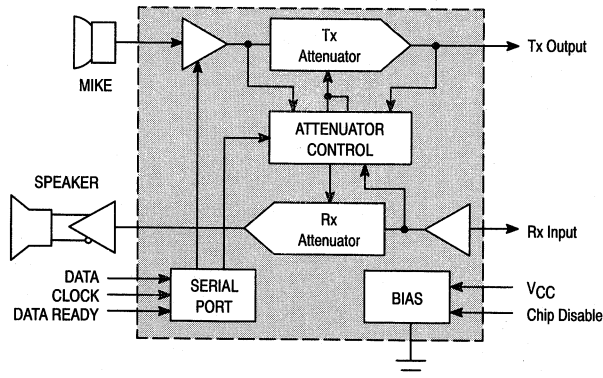

## Speakerphone (continued)

### Voice Switched Speakerphone Circuit

#### MC34118P, DW

$T_A = -20^\circ$  to  $+60^\circ\text{C}$ , Case 710, 751F

The MC34118 Voice Switched Speakerphone circuit incorporates the necessary amplifiers, attenuators, level detectors, and control algorithm to form the heart of a high quality hands-free speakerphone system. Included are a microphone amplifier with adjustable gain and mute control, Transmit and Receive attenuators which operate in a complementary manner, level detectors at input and output of both attenuators, and background noise monitors for both the transmit and receive channels. A dial tone detector prevents the dial tone from being attenuated by the Receive background noise monitor circuit. Also included are two line driver amplifiers which can be used to form a hybrid network in conjunction with an external coupling transformer. A high-pass filter can be used to filter out 60 Hz noise in the receive channel, or for other filtering functions. A high-pass filter can be used to filter out 60 Hz noise in the receive channel, or for other filtering functions. A high-pass filter can be used to filter out 60 Hz noise in the receive channel, or for other filtering functions.

The MC34118 may be operated from a power supply, or it can be powered from the telephone line, requiring typically

5.0 mA. The MC34118 can be interfaced directly to Tip and Ring (through a coupling transformer) for stand-alone operation, or it can be used in conjunction with a handset speech network and/or other features of a featurephone.

- Improved Attenuator Gain Range: 52 dB Between Transmit and Receive
- Low Voltage Operation for Line-Powered Applications (3.0 to 6.5 V)
- 4-Point Signal Sensing for Improved Sensitivity
- Background Noise Monitors for Both Transmit and Receive Paths
- Microphone Amplifier Gain Set by External Resistors — Mute Function Included
- Chip Disable for Active/Standby Operation
- On Board Filter Pinned-Out for User Defined Function
- Dial Tone Detector Inhibits Receive Idle Mode During Dial Tone Presence
- Compatible with MC34119 Speaker Amplifier

4

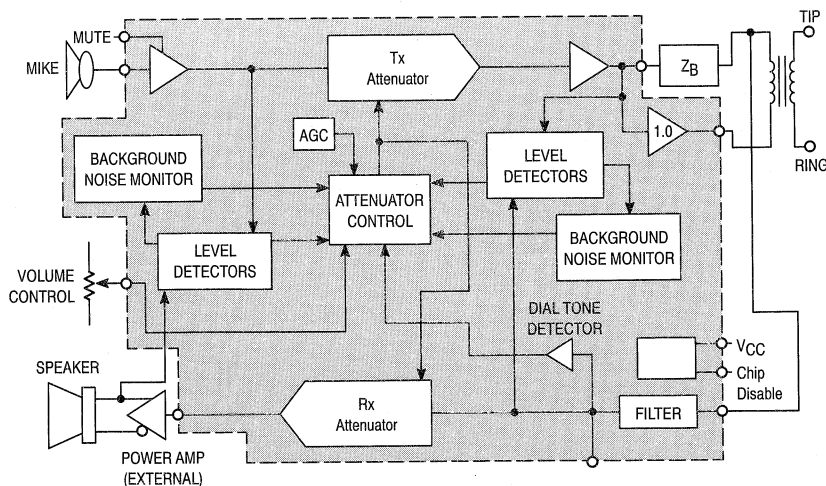

## Speakerphone (continued)

**Table 50. The Motorola Family of Speakerphone Integrated Circuits**

MC34018	MC34118	MC33218
Two point sensing with slow idle, background noise monitor in Tx path only	Four point sensing with both fast and slow idle modes, background noise monitors in both Rx and Tx paths	Two point sensing with slow idle, background noise monitors in both Rx and Tx paths
No dial tone detector in receive path	Receive path has dial tone detector	Receive path has dial tone detector
Attenuator Characteristics: <ul style="list-style-type: none"> <li>• Range: 44 dB</li> <li>• Tolerance: <math>\pm 4</math> dB</li> <li>• Gain tracking not specified</li> <li>• White noise is constant</li> </ul>	Attenuator Characteristics: <ul style="list-style-type: none"> <li>• Range: 52 dB</li> <li>• Tolerance: <math>\pm 2</math> dB</li> <li>• Gain Tracking: <math>&lt; 1</math> dB</li> <li>• White noise reduces with volume</li> </ul>	Attenuator Characteristics: <ul style="list-style-type: none"> <li>• Range: 52 or 26 dB (selectable)</li> <li>• Tolerance: <math>\pm 3</math> dB</li> <li>• Gain Tracking: <math>&lt; 1</math> dB</li> <li>• White noise reduces with volume</li> </ul>
External hybrid required	Hybrid amplifiers on board	External hybrid required
Speaker amplifier is on board (34 dB, 100 mW)	External speaker amplifier required (MC34119)	External speaker amplifier required (MC34119)
Filtering is external	Configurable filter on board	Filtering is external
Microphone amplifier has fixed gain and no muting	Microphone amplifier has adjustable gain and mute input	Microphone amplifier has adjustable gain, and can be muted through $\mu P$ port
Supply Voltage: 4.0 V to 11 V	Supply Voltage: 2.8 V to 6.5 V	Supply Voltage: 2.5 V to 6.5 V
Supply Current: 6.5 mA typ., 9.0 mA max	Supply Current: 5.5 mA typ., 8.0 mA max	Supply Current: 4.0 mA typ., 5.0 mA max
Speaker amplifier reduces gain to prevent clipping	Receive gain is reduced as supply voltage falls to prevent clipping	Receive gain is reduced as supply voltage falls to prevent clipping
Volume control is linear. Cannot override voice switched operation except through additional circuitry. Attenuator gain is fixed at 44 dB (slightly variable). No microphone mute.	Volume control is linear, and microphone mute has separate pin. Cannot override voice switched operation except through additional circuitry. Attenuator gain is fixed at 52 dB.	8-bit $\mu P$ serial port controls: <ul style="list-style-type: none"> <li>• Volume control (16 steps)</li> <li>• Microphone mute</li> <li>• Range selection (26 dB or 52 dB)</li> <li>• Force to transmit, idle, receive, or normal voice switched operation</li> </ul>
28 Pin DIP and SOIC packages	28 Pin DIP and SOIC packages	24 Pin narrow DIP and SOIC packages
External Required: <ul style="list-style-type: none"> <li>• 12 Resistors</li> <li>• 11 Capacitors (<math>\leq 1.0 \mu F</math>)</li> <li>• 8 Capacitors (<math>&gt; 1.0 \mu F</math>)</li> </ul>	External Required: <ul style="list-style-type: none"> <li>• 14 Resistors</li> <li>• 12 Capacitors (<math>\leq 1.0 \mu F</math>)</li> <li>• 9 Capacitors (<math>&gt; 1.0 \mu F</math>)</li> </ul>	External Required: <ul style="list-style-type: none"> <li>• 12 Resistors</li> <li>• 11 Capacitors (<math>\leq 1.0 \mu F</math>)</li> <li>• 4 Capacitors (<math>&gt; 1.0 \mu F</math>)</li> </ul>
Temperature Range: $-20^\circ$ to $+60^\circ C$	Temperature Range: $-20^\circ$ to $+60^\circ C$	Temperature Range: $-40^\circ$ to $+85^\circ C$

4

# Telephone Accessory Circuits

## Audio Amplifier

### MC34119P, D

$T_A = 0^\circ$  to  $+70^\circ\text{C}$ , Case 626, 751

A low power audio amplifier circuit intended (primarily) for telephone applications, such as speakerphones. Provides differential speaker outputs to maximize output swing at low supply voltages (2.0 V min.). Coupling capacitors to the speaker, and snubbers, are not required. Overall gain is externally adjustable from 0 to 46 dB. A Chip Disable pin permits powering-down to mute the audio signal and reduce power consumption.

- Drives a Wide Range of Speaker Loads (16 to 100  $\Omega$ )
- Output Power Exceeds 250 mW with 32  $\Omega$  Speaker
- Low Distortion (THD = 0.4% Typical)
- Wide Operating Supply Voltage (2.0 V to 16 V) — Allows Telephone Line Powered Applications.
- Low Quiescent Supply Current (2.5 mA Typical)
- Low Power-Down Quiescent Current (60  $\mu\text{A}$  Typical)

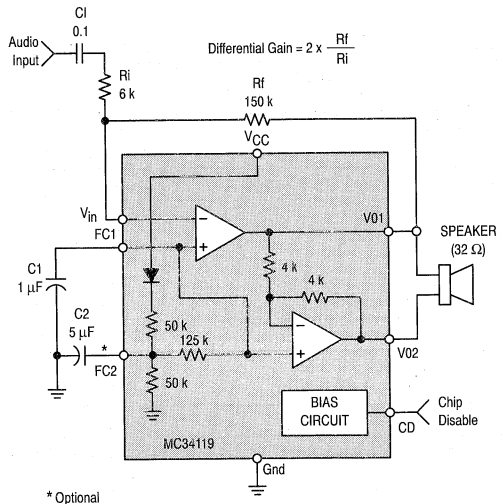

# 4

## Current Mode Switching Regulator

### MC34129P, D

$T_A = 0^\circ$  to  $+70^\circ\text{C}$ , Case 646, 751A

High performance current mode switching regulator for low-power digital telephones. Unique internal fault timer provides automatic restart for overload recovery. A start/run comparator is included to implement bootstrapped operation of VCC.

Although primarily intended for digital telephone systems, these devices can be used cost effectively in many other applications. On-chip functions and features include:

- Current Mode Operation to 300 kHz
- Automatic Feed Forward Compensation
- Latching PWM for Cycle-By-Cycle Current Limiting
- Latched-Off or Continuous Retry after Fault Timeout
- Soft-Start with Maximum Peak Switch Current Clamp
- Internally Trimmed 2% Bandgap Reference
- Input Undervoltage Lockout

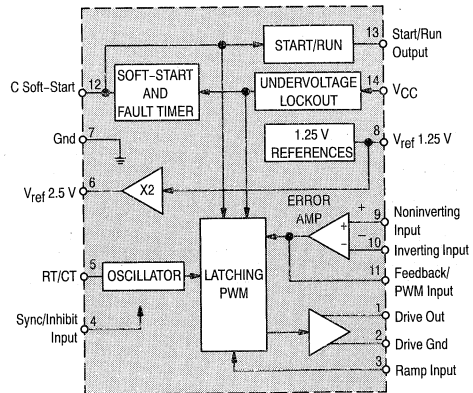

## Telephone Accessory Circuits (continued)

### 300 Baud FSK Modems

#### MC145442 Modem — CCITT V.21

Case 738, 751D

#### MC145443 Modem — Bell 103

Case 738, 751D

This powerful modem combines a complete FSK modulator/demodulator and an accompanying transmit/receive filter system on a single silicon chip. Designed for bidirectional transmission over the telephone network, the modem operates at 300 baud and can be obtained for compatibility with CCITT V.21 and Bell 103 specifications.

The modem contains an on-board carrier-detect circuit that allows direct operation on a telephone line (through a simple transformer), providing simplex, half-duplex, and full-duplex data communications. A built-in power amplifier is capable of driving  $-9.0$  dBm onto a  $600 \Omega$  line in the transmit mode.

CMOS processing keeps power dissipation to a very low  $45$  mW, with a power-down dissipation of only  $1.0$  mW... from a single  $5.0$  V power supply. Available in a 20 pin dual-in-line P suffix, and a wide body surface mount DW suffix.

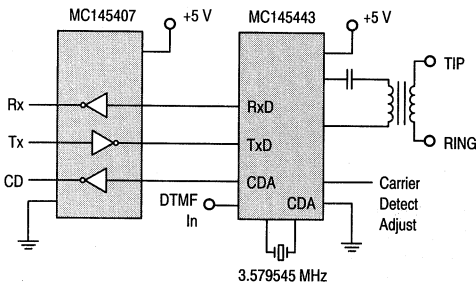

#### MC145444 — CCITT V.21

Case 804, 751D

This device includes the DTMF generator and call progress tone detector (CPTD) as well as the other circuitry needed for full-duplex, half-duplex, or simplex 300 baud data communication over a pair of telephone lines. It is intended for use with teletext system or remote control system applications.

The differential line driver is capable of driving  $0$  dBm into a  $600 \Omega$  load. The transmit attenuator is programmable in  $1$  dB steps.

### ADPCM Transcoder

#### MC145532

Case 620, 751G

The MC145532 Adaptive Differential Pulse Code Modulation (ADPCM) Transcoder provides a low cost, full-duplex, single-channel transcoder to (from) a  $64$  kbps

PCM channel from (to) either a  $16$  kbps,  $24$  kbps,  $32$  kbps, or  $64$  kbps channel.

- Complies with CCITT Recommendation G.721 (Geneva 1986)
- Complies with the American National Standard (T1.301-1987)
- Full-Duplex, Single-Channel Operation
- Mu-Law or A-Law Coding is Pin Selectable
- Synchronous or Asynchronous Operation
- Easily Interfaces with any Member of Motorola's PCM Codec-Filter Mono-Circuit Family or Other Industry Standard Codecs
- Serial PCM and ADPCM Data Transfer Rate from  $64$  kbps to  $5.12$  Mbps
- Power Down Capability for Low Cost Consumption
- The Reset State is Automatically Initiated when the Reset Pin is Released.
- Simple Time Slot Assignment Timing for Transcoder Applications
- Single  $5.0$  V Power Supply
- Evaluation Kit MC145536 EVK Supports the MC145532 as well as the MC145480 PCM Codec-Filter. (See PBX Architecture Pages for More Information.)

4

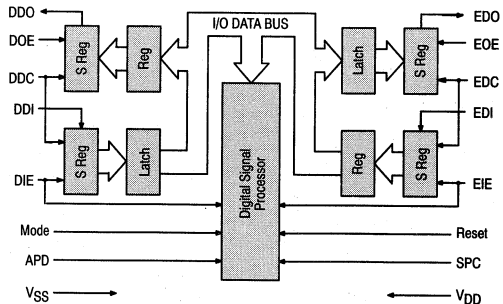

### Bit Rate Generators

#### MC14411

Case 709, 623

Internal (crystal controlled)  $1.843$  MHz oscillator and subsequent divider networks provide  $16$  different output clocks rates ranging from  $75$  Hz to  $1.843$  MHz for data communications equipment such as teleprinters, printers, CRT terminals and microprocessor systems.

#### MC145411

Case 648

Similar to the MC14411, this device utilizes a  $1.843$  MHz or  $3.6864$  MHz crystal frequency input divided to provide nine different output clock rates from  $150$  Hz to  $1.843$  MHz, or  $300$  Hz to  $3.6864$  MHz, respectively.



## Telephone Accessory Circuits (continued)

### Calling Line Identification (CLID) Receiver with Ring Detector

MC145447

Case 648, 751G

The MC145447 is designed to demodulate Bell 202 1200 baud FSK asynchronous data. Its primary application is in products that will be used to receive and display the calling number, or the message waiting indicator sent to subscribers from participating central office facilities of the public switched telephone network. The device also contains a carrier detect circuit and telephone ring detector which may be used to power up the device.

Applications include adjunct boxes, answering machines, feature phones, fax machines, and computer interface products.

- Ring Detector On-Chip
- Ring Detect Output for MCU Interrupt
- Power-Down Mode Less Than 1.0  $\mu$ A
- Single Supply: 3.5 V to 6.0 V
- Pin Selectable Clock Frequencies: 3.68 MHz, 3.58 MHz, or 455 kHz
- Two-Stage Power-Up for Power Management Control

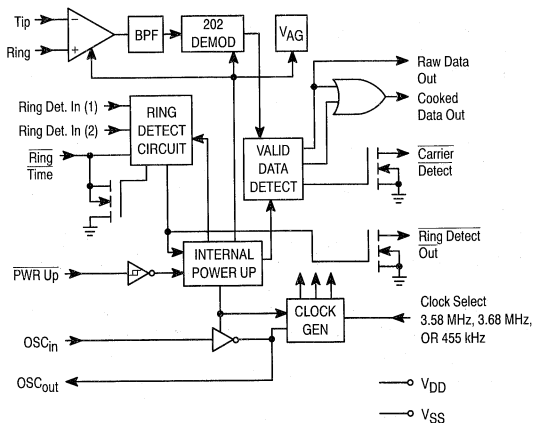

### Calling Line ID Receiver Evaluation Kit

MC145460EVK

The MC145460EVK is a low cost evaluation platform for the MC145447. The MC145460EVK facilitates development and testing of products that support the Bellcore customer premises equipment (CPE) data interface, which enables services such as Calling Number Delivery (CND). The MC145447 can be easily incorporated into any telephone, FAX, PBX, key system, answering machine, CND adjunct box or other telephone equipment with the help of the MC145460EVK development kit.

- Easy Clip-On Access to Key MC145447 Signals
- Generous Prototype Area
- Configurable for MC145447 Automatic or External Power Up Control
- EIA-232 and Logic Level Ports for Connection to any PC or MCU Development Platform
- Carrier Detect, Ring Detect and Data Status LEDs
- Optional Tip and Ring Input Protection Network
- MC145460EVK User Guide, MC145447 Data Sheet, and Additional MC145447 Sample Included

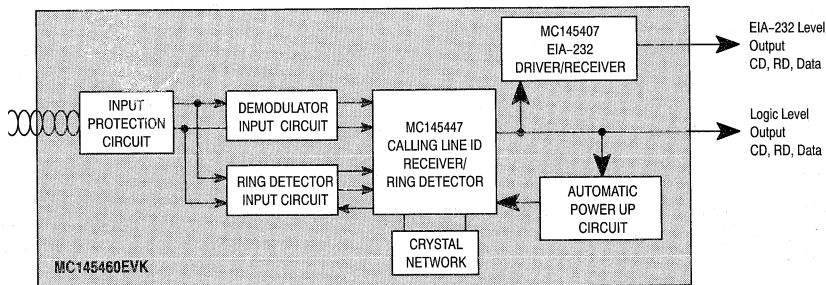

Telephone Accessory Circuits (continued)

## Continuously Variable Slope Delta (CVSD) Modulator/Demodulator

**MC34115P**

$T_A = 0^\circ$  to  $+70^\circ\text{C}$ , Case 648

**MC3417/18L**

$T_A = 0^\circ$  to  $+70^\circ\text{C}$ , Case 620

**MC3517/18L**

$T_A = -55^\circ$  to  $+125^\circ\text{C}$ , Case 620

Provides the A/D–D/A function of voice communications by digital transmission.

The MC3517/18 series of CVSDs is designed for military secure communications and commercial telephone applications. A single IC provides both encoding and decoding functions in a 16 pin package.

- Encode and Decode Functions on the Same Chip with a Digital Input for Selection
- CMOS Compatible Digital Output
- Digital Input Threshold Selectable ( $V_{CC}/2$  Reference Provided On–Chip)
- MC3417/MC3517/MC34115 Have a 3–Bit Algorithm (General Communications)
- MC3418/MC3518 Have a 4–Bit Algorithm (Commercial Telephone)

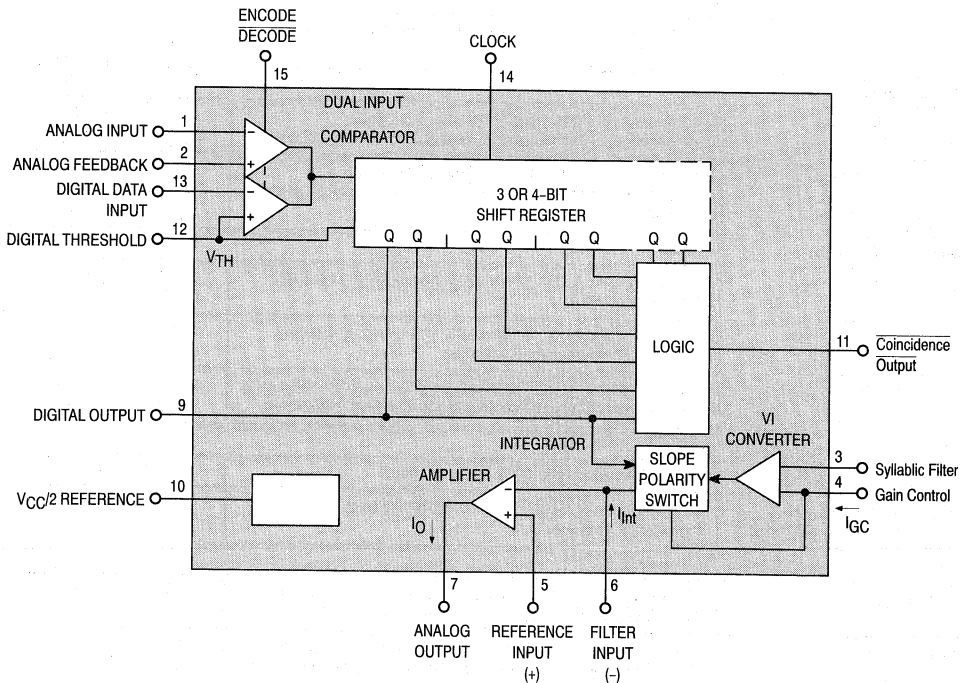

**Table 51. Summary of Bipolar Telecommunications Circuits**

Function	Features	Suffix/ Package	Device
<b>SLICs</b>			
PBX Applications	All gains externally programmable, most BORSHT functions, current limit adjustable to 100 mA.	L726	MC3419-1
Central Office, Remote Terminals, PBX Applications	All gains externally programmable, most BORSHT functions, current limit adjustable to 50 mA, 58 dB Longitudinal Balance, -21.6 V to -42 V.	P/738 FN/776	MC33121
Central Office, Remote Terminals, PBX Applications	All gains externally programmable, most BORSHT functions, current limit adjustable to 50 mA, 58 dB Longitudinal Balance, -42 V to -58 V.	P/738 FN/776	MC33120
Central Office, Remote Terminals, PBX Applications	All gains externally programmable, most BORSHT functions, current limit adjustable to 50 mA, 58 dB Longitudinal Balance, -21.6 V to -58 V, ring trip, on-hook transmission, polarity reversal.	TBD(1)	MC33122
<b>Complete Telephone Circuit</b>			
POTS Circuit + MPU Dialing	Speech network, tone ringer, DC loop current interface, DTMF dialer with serial port control.	P/711 FN/777	MC34010
<b>Tone Ringers</b>			
Adjustable Tone Ringer	Single-ended output, meets FCC requirements, adjustable REN, different warble rates.	P/626 D751	MC34012-1, 2, 3
Adjustable Tone Ringer	Differential output, meets FCC requirements, adjustable REN, different warble rates.	P/626 D751	MC34017-1, 2, 3
Adjustable Tone Ringer	Differential output, meets FCC requirements, adjustable REN, single warble rates.	P/626 D751	MC34217
<b>Speech Networks</b>			
Basic Phone Line Interface	Loop current interface, speech network, line length compensation, speech/dialing modes, Bell System compliant.	P/707 DW/751D	MC34014
Basic Phone Line Interface	Loop current interface, speech network, line length compensation, speech/dialing modes, Bell System and foreign countries.	P/707 DW/751D	MC34114
<b>Speakerphone Circuits</b>			
Complete Speaker Phone with Speaker Amplifier	All level detection (2 pt.), attenuators, and switching controls, mike and speaker amp.	P/710 DW751F	MC34018
Complete Speaker Phone with Hybrid, Filter	All level detection (4 pt.), attenuators, and switching controls, mike amp with mute, hybrid, and filter.	P/710 DW751F	MC34118
Complete Speaker Phone with MPU Interface	All level detection, attenuators, and switching controls, mike amp, MPU interface for: volume control, mode selection, mike mute.	P/724 DW751E	MC33218
<b>Audio Amplifiers</b>			
1 Watt Audio Amp	1.0 W output power into 16 $\Omega$ , 35 V maximum.	D/751	MC13060
Low Voltage Audio Amp	400 mW, 8.0 to 100 $\Omega$ , 2.0 to 16 V, differential outputs, chip-disable input pin.	P/626 D751	MC34119
<b>Companders</b>			
Basic Compander	2.1 V to 7.0 V, no precision externals, 80 dB range, -40° to +85°C, independent compressor and expander.	P/646 D/751A	MC33110
Compander with Features	3.0 V to 7.0 V, no precision externals, 80 dB range, -40° to +85°C, independent compressor and expander, pass through and mute functions, two op amps.	P/648 D/751B	MC33111

(1) To Be Determined

4

**Table 51. Summary of Bipolar Telecommunications Circuits (continued)**

Function	Features	Suffix/ Package	Device
<b>Switching Regulator</b>			
Current Mode Regulator	For phone line power applications, soft-start, current limiting, 2% accuracy.	P/646 D/751A	MC34129
<b>Voice Encoder/Decoders</b>			
Continuously Variable Slope Modulator/Demodulator (CVSD)	Telephone quality voice encoding/decoding, variable clock rate, 3-bit coding, for secure communications, voice storage/retrieval, answering machines, 0° to 70°C.	P/738 DW/751G	MC34115
	Same as above except 4-bit coding.	P/738 DW751G	MC3418
	Same as MC34115, -55° to 125°C temperature range.	L/620	MC3517
	Same as MC3418, -55° to 125°C temperature range.	L/620	MC3518

(1) To Be Determined

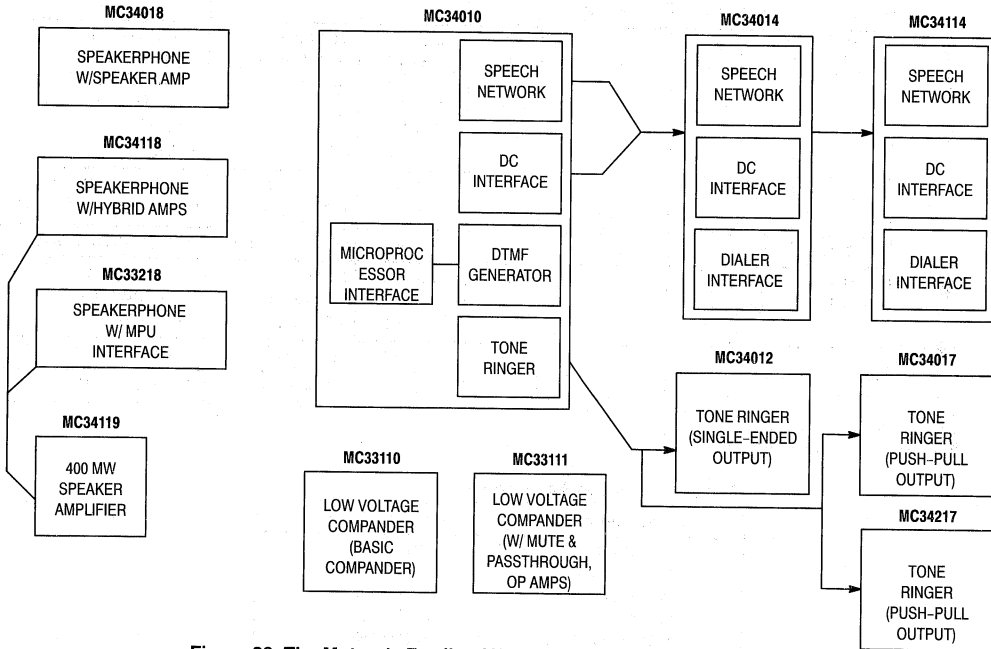

**Figure 23. The Motorola Family of Handset Telecom Integrated Circuits**

# Phase-Locked-Loop Components

Motorola offers a choice of phase-locked loop components ranging from complete functional frequency synthesizers for dedicated applications to a wide selection of general purpose PLL circuit elements. Technologies include

CMOS for lowest power consumption and bipolar for high speed operation. Typical applications include TV, CATV, radios, scanners, cordless telephones plus home and personal computers.

**Table 52. PLL Frequency Synthesizers**

Divider Programming Format	External Prescaler Modulus	Single-Ended (3-State) Phase Detector Output	Double-Ended Phase Detector Output	$f_{max}$ (MHz)	Functional Supply Range (V)	Device	Suffix/Package	
Serial	Single	✓	✓	20	3.0-9.0	MC145155-2	P/707, DW/751D, FN/775	
		✓	✓	20	3.0-9.0	MC145157-2	P/648, DW/751G, FN/775	
	Dual	✓ ✓ (1)	—	15	3.0-9.0	MC145149	P/738, DW/751D	
		✓	✓	20	3.0-9.0	MC145156-2	P/738, DW/751D, FN/775	
		✓	✓	20	3.0-9.0	MC145158-2	P/648, DW/751G, FN/775	
	Dual	Frequency Detector	Analog Detector	15	3.0-9.0	MC145159-1	P/738, DW/751D, FN/775	
	Not Required	Not Required	✓ ✓ (1)	—	60	2.5-5.5	MC145161	P/648, DW/751G
			✓ ✓ (1)	—	60	2.5-5.5	MC145167	P/648, DW/751G
			✓ ✓ (1)	—	60	2.5-5.5	MC145169	P/648, DW/751G
			✓	✓	160(2)	2.5-6.0	MC145170	P/648, D/751B
✓			✓	1100	4.5-5.5	MC145191	F/751J	
✓			✓	1100	2.7-5.0	MC145192	F/751J	
Parallel	Single	✓	—	4	4.5-12	MC145106	P/707, DW/751D, FN/775	
		✓	✓	20	3.0-9.0	MC145151-2	P/710, FN/776, DW/751F	
	Dual	—	✓	20	3.0-9.0	MC145152-2	P/710, FN/776, DW/751F	
	Not Required	Not Required	✓ ✓ (1)	—	60	2.5-5.5	MC145160	P/707, DW/751D
			✓ ✓ (1)	—	60	2.5-5.5	MC145166	P/648, DW/751G
✓ ✓ (1)			—	60	2.5-5.5	MC145168	P/648, DW/751G	
4-Bit Bus	Single	✓	✓	20	3.0-9.0	MC145145-2	P/707, DW/751D	
	Dual	✓	✓	20	3.0-9.0	MC145146-2	P/738, DW/751D	

(1) Accommodates two loops per package.  
 (2) 180 MHz version available, see data sheet.

**Table 53. Intended Applications**

General Purpose	Cordless Phones
MC145106	MC145160
MC145145-2	MC145161
MC145146-2	MC145166
MC145149	MC145167
MC145151-2	MC145168
MC145152-2	MC145169
MC145155-2	
MC145156-2	
MC145157-2	
MC145158-2	
MC145159-1	
MC145170	
MC145191	
MC145192	

4

## Phase-Locked-Loop Components (continued)

**Table 54. Additional Phase-Locked Loop Functions**

Function	Family	Devices (0° to 70°C)	Suffix/Package
<b>Oscillators</b>			
Crystal Oscillator	MECL	MC12061	P/648, L/620
Voltage-Controller Oscillator	MECL	MC1648(3)	P/646, L/632, F/607
Voltage-Controlled Multivibrator	MECL	MC1658(3)	P/648, L/620
Dual Voltage-Controlled Multivibrator	TTL	MC4024/ MC4324(1)	P/648, L/632, F/607
Voltage-Controller Oscillators	TTL/LS	SN74LS724	P.626, L/693
<b>Phase Detectors</b>			
Digital Mixer	MECL	MC12000	P/646, L/632
Phase-Frequency Detector	MECL	MC12040	
Phase-Frequency Detector	TTL	MC4044 MC4344(1)	P/646, L/632, F/607
Analog Mixer, Double Balanced	MECL	MC12002(3)	P/646, L/632
Modulator/Demodulator	Linear	MC1496(2)/ MC1596(1)	P/646, L/632
<b>Control Functions</b>			
Counter-Control Logic	MECL	MC12014	P/648, L/620
<b>Prescalers/Counters</b>			
UHF — 2,500 MHz	MECL	MC1690(3)	F/650, L/620
2-Modulus ÷ 5/ ÷ 6, 600 MHz	MECL	MC12009(3)	P/648, L/620
2-Modulus ÷ 8/ ÷ 9, 600 MHz	MECL	MC12011(3)	
2-Modulus ÷ 10/ ÷ 11, 600 MHz	MECL	MC12013(3)	
Low Power 2-Modulus ÷ 32/ ÷ 33, 225 MHz	MECL	MC12015(4)	P/626, D/751
Low Power 2-Modulus ÷ 40/ ÷ 41, 225 MHz	MECL	MC12016(4)	
Low Power 2-Modulus ÷ 64/ ÷ 65, 225 MHz	MECL	MC12017(4)	
Low Power 2-Modulus ÷ 128/ ÷ 129, 520 MHz	MECL	MC12018(4)	
Low Power 2-Modulus ÷ 20/ ÷ 21, 225 MHz	MECL	MC12019(4)	
Low Power 2-Modulus ÷ 64/ ÷ 65, ÷ 128/ ÷ 129 Pos. Edge 1.1 GHz	MECL	MC12022A(4)	
Low Power 2-Modulus ÷ 64/ ÷ 65, ÷ 128/ ÷ 129 Neg. Edge 1.1 GHz	MECL	MC12022B(4)	
Low Power ÷ 64 Prescaler, 225 MHz 3.2 to 5.5 V <sub>CC</sub>	MECL	MC12023	
Low Power ÷ 64 Prescaler, 1.1 GHz	MECL	MC12073	
Low Power ÷ 256 Prescaler, 1.1 GHz	MECL	MC12074	
UHF ÷ 2 Prescaler, 750 MHz	MECL	MC12090	
Programmable ÷ N Decade	TTL	MC4316/ MC4316(1)	P/648, L/620, F/650

(1) T<sub>A</sub> = -55° to +125°C

(3) T<sub>A</sub> = -30° to +85°C

(2) T<sub>A</sub> = 0° to 70°C

(4) T<sub>A</sub> = -40° to +85°C

Plastic packages available for commercial temperature range only.

NOTE: For more information see SG366/D.

4

# Communications Circuits Package Overview

4



CASE 607  
CERAMIC  
F SUFFIX

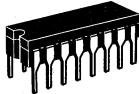

CASE 620  
CERAMIC  
L SUFFIX

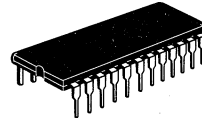

CASE 623  
CERAMIC  
L SUFFIX



CASE 626  
PLASTIC  
P SUFFIX

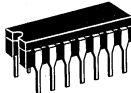

CASE 632  
CERAMIC  
L SUFFIX

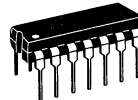

CASE 646  
PLASTIC  
P SUFFIX

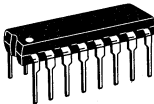

CASE 648  
PLASTIC  
P SUFFIX

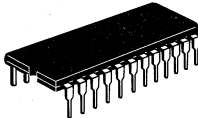

CASE 649  
PLASTIC  
P SUFFIX

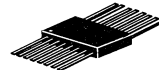

CASE 650  
CERAMIC  
F SUFFIX



CASE 693  
CERAMIC  
L SUFFIX

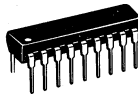

CASE 707  
PLASTIC  
P SUFFIX

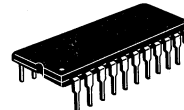

CASE 708  
PLASTIC  
P SUFFIX

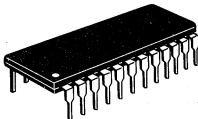

CASE 709  
PLASTIC  
P SUFFIX

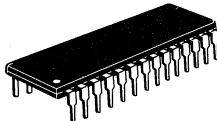

CASE 710  
PLASTIC  
P SUFFIX

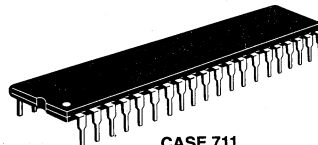

CASE 711  
CERAMIC  
P SUFFIX

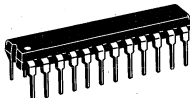

CASE 724  
PLASTIC  
P, N SUFFIX

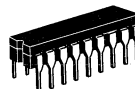

CASE 726  
CERAMIC  
L SUFFIX

## Communications Circuits Package Overview (continued)

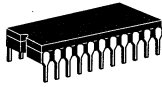

**CASE 736, 736A**  
CERAMIC  
L SUFFIX

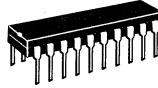

**CASE 738**  
PLASTIC  
P SUFFIX



**CASE 751**  
PLASTIC  
SO-8, SOP-8  
D SUFFIX



**CASE 751A**  
PLASTIC  
SO-14  
D SUFFIX



**CASE 751B**  
PLASTIC  
SO-16  
D SUFFIX



**CASE 751D**  
PLASTIC  
SO-20L  
DW SUFFIX



**CASE 751E**  
PLASTIC  
SO-24L  
DW SUFFIX



**CASE 751F**  
PLASTIC  
SO-28L  
DW SUFFIX



**CASE 751G**  
PLASTIC  
SO-16L  
DW SUFFIX



**CASE 751J**  
PLASTIC  
SO-20  
F SUFFIX



**CASE 775**  
PLASTIC  
PLCC-20  
FN SUFFIX



**CASE 776**  
PLASTIC  
PLCC-28  
FN SUFFIX



**CASE 777**  
PLASTIC  
PLCC-44  
FN SUFFIX



**CASE 779**  
PLASTIC  
PLCC-68  
FN SUFFIX



**CASE 847**  
PLASTIC  
PQFP-68  
FU SUFFIX

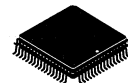

**CASE 847B**  
CERAMIC  
CQFP-68  
FE SUFFIX

4



**4**

# Consumer Electronic Circuits

---

## In Brief . . .

These integrated circuits reflect Motorola's continuing commitment to semiconductor products necessary for consumer system designs. This tabulation is arranged to simplify selection of consumer integrated circuit devices that satisfy the primary functions for home entertainment products, including Television, Hi-Fi Audio and AM/FM Radio.

	<b>Page</b>
Entertainment Radio Receiver Circuits . . . . .	4.8-2
Entertainment Receiver RF/IF . . . . .	4.8-2
C-Quam® AM Stereo Decoders . . . . .	4.8-2
Audio Amplifiers . . . . .	4.8-2
Audio Attenuator . . . . .	4.8-2
Video Circuits . . . . .	4.8-3
Encoders . . . . .	4.8-3
Decoders . . . . .	4.8-3
Video Capture Chip Sets . . . . .	4.8-3
Deflection . . . . .	4.8-3
Comb Filters . . . . .	4.8-4
IF Circuits . . . . .	4.8-4
Tuner PLL Circuits . . . . .	4.8-4
Modulators . . . . .	4.8-4
Video Data Converters . . . . .	4.8-4
Television Subsystems . . . . .	4.8-4
Monitor Subsystem . . . . .	4.8-4
Sound . . . . .	4.8-5
Miscellaneous . . . . .	4.8-5
Circuit Descriptions and Diagrams . . . . .	4.8-6
Remote Control Circuits . . . . .	4.8-25
Package Overview . . . . .	4.8-26

# Entertainment Radio Receiver Circuits

**Table 55. Entertainment Receiver RF/IF**

Function	Features	Suffix/ Package	Device
E.T.R. Front End	Mixer/VCO/AGC for Electronically Tuned AM Stereo Receivers	P/648 D751B	MC13025

**Table 56. C-Quam® AM Stereo Decoders**

Function	Features	Suffix/ Package	Device
Basic AM Stereo Decoder	Monaural/Stereo AM Detector/Indicator, 6 to 10 V Operation	P/738	MC13020
Advanced AM Stereo Decoder	Medium Voltage 2 to 8 V, Decoder and IF Amp	DW/751F	MC13022
AM Stereo Personal Radio	Complete Low Voltage AM Stereo Receiver	P/724	MC13024
Low V AM Stereo Receiver	IF/Decoder for Advanced C-Quam Receivers	D/751B	MC13028

**Table 57. Audio Amplifiers**

Function	P <sub>O</sub> (Watts)	V <sub>CC</sub> Vdc Max	V <sub>in</sub> @ Rated P <sub>O</sub> mV Typ	I <sub>D</sub> mA Typ	R <sub>L</sub> (Ohms)	Suffix/ Package	Device
Mini Watt SOIC Audio Amp	1.0 W	35	80	11	16	D/751	MC13060
Low Power Audio Amp	400 mW	16	—	2.5 mA	8-100	D/751 P/626	MC34119

4

**Table 58. Audio Attenuator**

Function	V <sub>CC</sub> Range (Vdc)	THD (%)	Tone Control Range dB Typ	Attenuation Range dB Typ	Suffix/ Package	Device
Electronic Attenuator	8-18	0.6 Typ	± 13	80	P/626	MC3340

# Video Circuits

**Table 59. Video Circuits**

Function	Features	Suffix/ Package	Device
----------	----------	--------------------	--------

**Encoders**

RGB to PAL/NTSC Encoder	RGB and Sync inputs, Composite Video out; PAL/NTSC selectable.	P/738 DW/751D	MC1377
Advanced RGB to PAL/NTSC Encoder	RGB and Sync inputs, Composite Video and S-VHS out; PAL/NTSC selectable; subcarrier from crystal or external source.	P/738 DW/751D	MC13077

**Decoders**

TV Color Processor	PAL/NTSC input, RGB outputs; also RGB inputs, Fast blanking, ideal for text, graphics, overlay.	P/711	TDA3301B
TV Color Processor	PAL/NTSC input, RGB outputs.	P/724	TDA3330
Chroma 10 Timebase and Color NTSC/PAL Decoder	PAL/NTSC input, RGB outputs; horizontal and vertical timing processors.	P/711	MC13017
Chroma 4 Multistandard Decoder (TV set)	PAL/NTSC/S-VHS input, RGB outputs; horizontal and vertical timing outputs; all digital internal filters, no external tank; $\mu$ P and crystal controlled.	P/711	MC44001
Chroma 4 Multistandard Decoder (Multimedia)	PAL/NTSC/S-VHS input, RGB/YUV outputs; horizontal and vertical timing outputs; all digital internal filters, no external tanks; $\mu$ P and crystal controlled.	FN/777	MC44011

**Video Capture Chip Sets**

Chroma 4 Multistandard Decoder (Multimedia)	PAL/NTSC/S-VHS input, RGB/YUV outputs; horizontal and vertical timing outputs; all digital internal filters, no external tanks; $\mu$ P and crystal controlled.	FN/777	MC44011
PAL Digital Delay Line	For PAL applications of the MC44011 and MC44001.	P/648 D/751	MC44140
Pixel Clock PLL/Sync Sep.	PAL/NTSC sync separator, 6–40 MHz pixel clock PLL.	D/751	MC44145
Triple 8-Bit Video DAC	TTL inputs, 75 $\Omega$ drive outputs.	FU/824	MC44200
Triple 8-Bit Video A/D	Video clamps for RGB/YUV, 15 MHz, TTL outputs.	FN/777	MC44250
	Video clamps for RGB/YUV, 18 MHz, High Z TTL outputs.	FN/777	MC44251
Advanced NTSC Comb Filter	Composite Video input; YC outputs in digital and analog form; all digital internal filters.	FU/898	MC141621
Advanced PAL/NTSC Comb Filter	Composite Video input; YC outputs in digital and analog form; all digital internal filters.	FU/898	MC141625

**Deflection**

Horizontal Processor	Linear balanced phase detector, oscillator and predriver, adjustable DC loop gain and duty cycle.	P/626	MC1391
Waveform Generator for Monitors	Provides geometry correction by generating 10 waveforms to modulate deflection circuitry. Supports multifrequency operation.	P/711	MC1388
Line Deflection Transistor Driver	Provides optimum drive control of the power transistor, peak current limiting, overvoltage and thermal protection.	P/648	MC44614
Waveform Generator for Projection TV Convergence Function	Provides geometry correction by generating 18 waveforms to modulate deflection circuitry. Supports multifrequency operation.	P/711	MC44615A

**4**

**Table 59. Video Circuits (continued)**

Function	Features	Suffix/ Package	Device
<b>Comb Filters</b>			
Enhanced Comb Filter	Fast 8–Bit A/D Converter, Two 8–Bit D/A Converters, Two Line–Delay Memories, utilizes NTSC Subcarrier Frequency Clock, CMOS Technology	FU/898	MC141620
Advanced NTSC Comb Filter	Composite Video input; YC outputs in digital and analog form; all digital internal filters.	FU/898	MC141621
Advanced PAL/NTSC Comb Filter	Composite Video input; YC outputs in digital and analog form; all digital internal filters.	FU/898	MC141625
<b>IF Circuits</b>			
Advanced Video IF	Complete video/audio IF system for high performance analog TV receivers.	P/724 DW/751F	MC44301
Video Detector	3rd IF, video detector, video buffer and AFC buffer.	P/626	MC1330A
IF Amplifier	1st and 2nd video IF amplifiers, 50 dB gain at 45 MHz, 60 dB AGC range.	D/751 P/626	MC1350
<b>Tuner PLL Circuits</b>			
PLL Tuning Circuits	1.3 GHz, 20 mV sensitivity, selectable prescaler, op amp, 7 band buffers, I <sup>2</sup> C interface.	P/707	MC44802A
	1.3 GHz, 5.0 mV sensitivity, selectable prescaler, op amp, 4 band buffers, SPI interface, lock detect.	P/648 D/751	MC44807 MC44817
	1.3 GHz, 10 mV sensitivity, selectable prescaler, op amp, 7 band buffers, I <sup>2</sup> C interface, 3 DACs.	P/738	MC44810
	1.3 GHz, 20 mV sensitivity, prescaler, 3 band buffers, I <sup>2</sup> C interface, replacement for Siemens MPG3002.	D/751	MC44824
	1.3 GHz, 5.0 mV sensitivity, prescaler, op amp, 4 band buffers, I <sup>2</sup> C interface, lock detect.	D/751	MC44818
<b>Modulators</b>			
Color TV Modulator	RF Oscillator and Modulator.	P/626	MC1373
Color TV Modulator with Sound	RF Oscillator/Modulator, and FM Sound Oscillator/Modulator.	P/646	MC1374
<b>Video Data Converters</b>			
Single Channel A/D	7–Bit, 25 MHz, 2.0 V input range, ± 5.0 V supplies, TTL output, no pipeline delay.	P/738 DW/751D	MC10321
	8–Bit, 25 MHz, 2.0 V input range, ± 5.0 V supplies, TTL output, no pipeline delay.	P/709 DW/751E	MC10319
Triple 8–Bit Video A/D	Video clamps for RGB/YUV, 15 MHz conversion.	FN/777	MC44250
	Video clamps for RGB/YUV, 18 MHz conversion, high Z outputs.	FN/777	MC44251
Single Channel 8–Bit Video DAC	40 MSPS, video controls ± 5.0 V, TTL inputs.	P/649	MC10322
	40 MSPS, video controls – 5.0 V, ECL inputs.	P/649	MC10324
Triple 8–Bit Video DAC	TTL inputs, 75 Ω drive outputs.	FU/824	MC44200
<b>Television Subsystems</b>			
Monomax Black and White TV Subsystem	IF, Video processor, horizontal and vertical timing, for NTSC applications, 525 line systems.	P/710	MC13001X
	IF, Video processor, horizontal and vertical timing, for PAL applications, 625 line systems.	P/710	MC13007X
<b>Monitor Subsystem</b>			
Multimode Color Monitor Processor	Triple video amplifiers, horizontal PLLs and deflection timing, vertical ramp generator, 30 to 57 kHz.	B/0051	MC13081

**4**

**Table 59. Video Circuits (continued)**

Function	Features	Suffix/ Package	Device
<b>Sound</b>			
Sound IF Detector	Interchangeable with ULN2111A.	P/646	MC1357
Sound IF with Preamp	Sound IF, Low Pass Filter, FM Detector, DC Volume Control, Preamplifier, 100 $\mu$ V sensitivity, 4.0 W output into 16 $\Omega$ .	P/648C	TDA3190
<b>Miscellaneous</b>			
Video Overlay Synchronizer	Complete Color TV Video Overlay Synchronizer, remote or local system control.	P/711 FN/777	MC1378
Subcarrier Reference Generator	Provides continuous subcarrier sine wave and 4x subcarrier, locked to incoming burst.	P/626 D/751	MC44144
Closed Caption Decoder	Conforms to FCC, NTSC standards, underline and italics control.	P/707	MC144143
Sync Separator/Pixel Clock PLL	PAL/NTSC sync separator with vertical and composite sync output, 6 to 40 MHz pixel clock PLL.	D/751	MC44145
Dual Video Amplifiers	Gain @ 4.43 MHz = 6 dB $\pm$ 1 dB, fixed gain, internally compensated, CMOS Technology.	P/626 F/904	MC14576B
	Gain @ 5 MHz = 10 dB max, 10 MHz = 6 dB max, adjustable gain, internally compensated, CMOS Technology.	P/626 F/904	MC14577B
Transistor Array	One differential pair and 3 isolated transistors, 30 V, 50 mA.	D/751	CA3146
	One differential pair and 3 isolated transistors, 15 V, 50 mA.	P/626 D/751	MC3346

Video Circuits (continued)

4

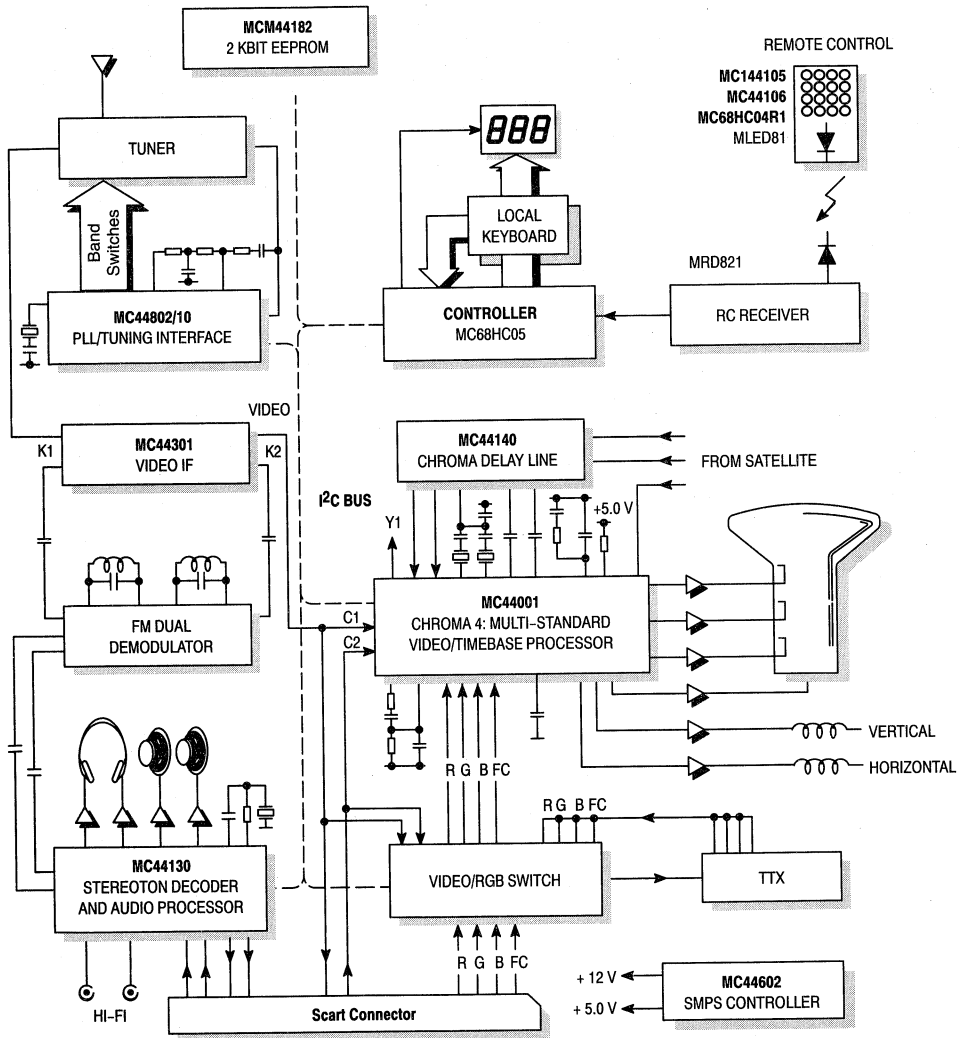

Figure 1. Chroma 4 Family Block Diagram

## Video Circuits (continued)

Bringing video into the personal computer allows a multitude of multimedia application dreams to become possible. Old applications can be done in new ways. Totally new applications, before impossible, become reality.

Moving beyond text and graphics to real images is what Motorola can bring to the user. Utilizing Motorola integrated circuits, video can be captured, processed and brought onto the screen where the video image can be scaled, clipped,

zoomed, windowed, overlaid, or process enhanced in ways never before possible.

Also included in this selector guide you will find products for TV and other TV related functions that will allow you to produce advanced TV products. These products span the range of applications including tuner control, video decoding, closed-captioning, stereo sound decoding and video encoding and synchronizing.

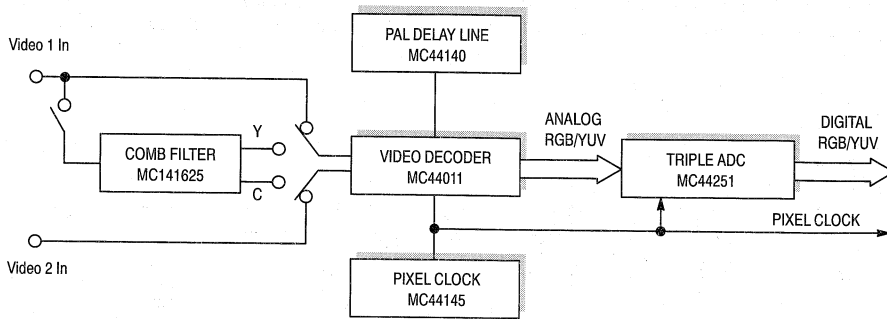

Figure 2. Video Input Processing

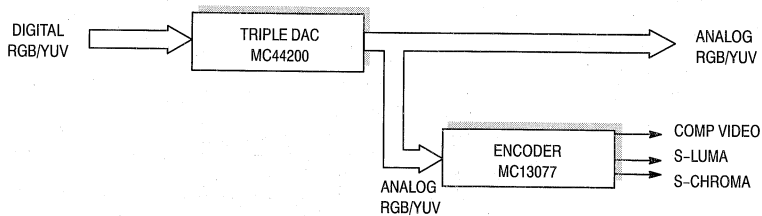

Figure 3. Video Output Processing

4



## Composite Video Overlay Synchronizer

MC1378P, FN

Case 711, 777

The MC1378 contains a complete encoder function, i.e. quadrature color modulators, RGB matrix, and blanking level clamps, plus a complete complement of synchronizers to lock a microcomputer based video source to any remote video source. The MC1378 can be used as a local system timing and encoding source, but it is most valuable when used to lock the microcomputer source to a remotely originated video signal.

- Contains All Needed Reference Oscillators
- Can Be Operated in PAL or NTSC Mode, 625 or 525 Line
- Wideband, Full Fidelity Color Encoding
- Local or Remote Modes of Operation
- Minimal External Components
- Single 5.0 V Supply
- Works with Non-Standard Video

4

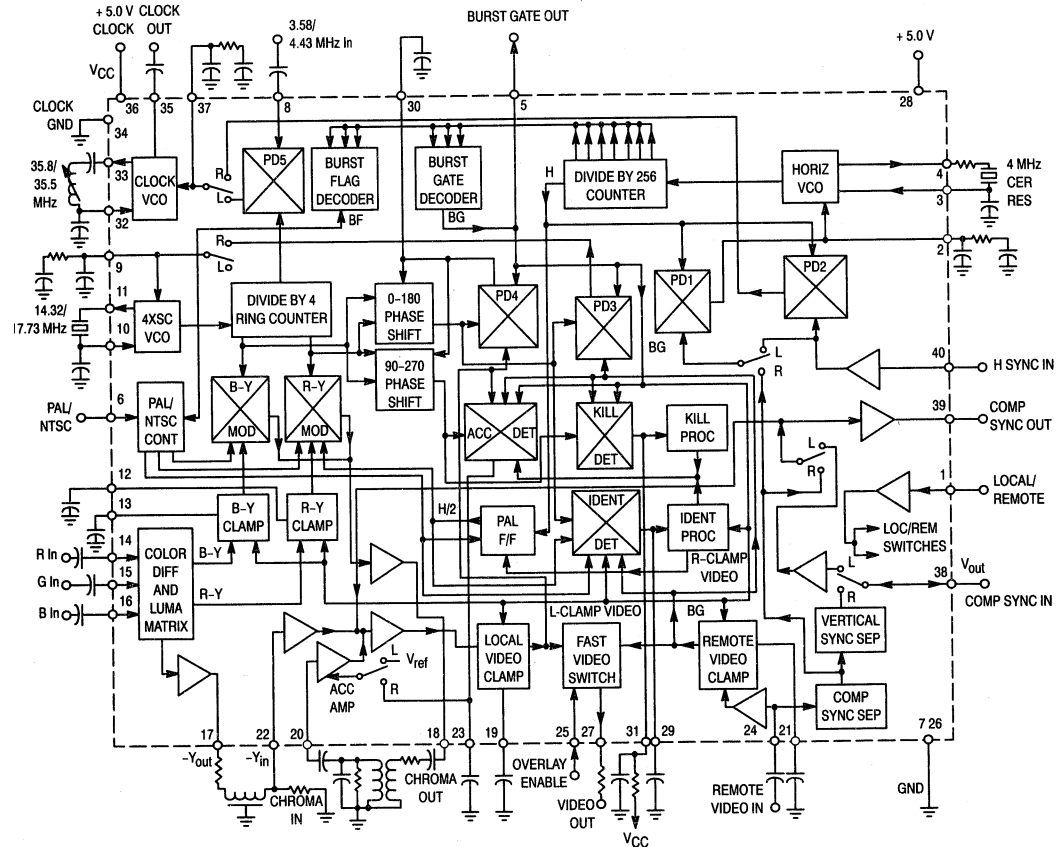

## Video Circuits (continued)

# Advanced PAL/NTSC Encoder

MC13077P, DW

Case 738, 751D

The MC13077 is an economical, high quality, RGB encoder for PAL or NTSC applications. It accepts red, green, blue and composite sync inputs and delivers either composite PAL or NTSC video, and S-Video Chroma and Luma outputs. The MC13077 is manufactured using Motorola's high density, bipolar MOSAIC® process.

- Single 5.0 V Supply
- Composite Output

- S-Video Outputs
- PAL/NTSC Switchable
- PAL Squarewave Output
- PAL Sequence Resettable
- Internal/External Burst Flag
- Modulator Angles Accurate to 90°
- Burst Position/Duration Determined Digitally
- Subcarrier Reference from a Crystal or External Source

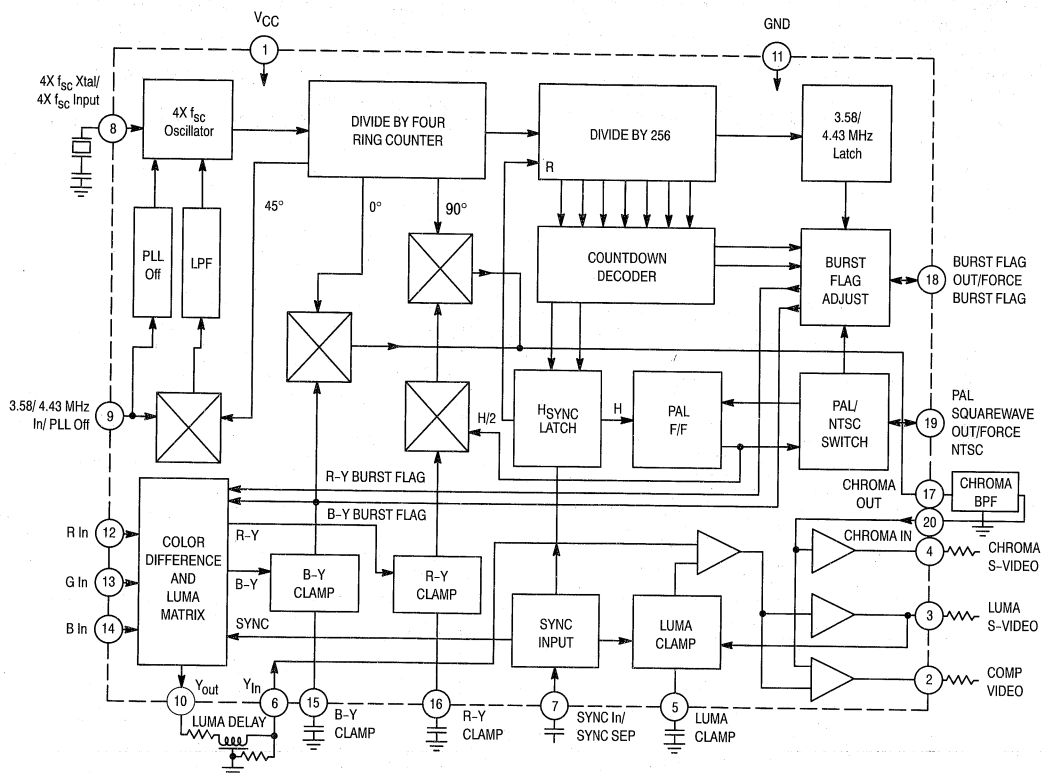

4

# Multistandard Video/Timebase Processor

## MC44001P

Case 711

The MC44001 is a highly advanced circuit which performs most of the basic functions required for a color TV. All of its advanced features are under processor control via an I<sup>2</sup>C bus, enabling potentiometer controls to be removed completely. In this way the component count may be reduced dramatically, allowing significant cost savings together with the possibility of implementing sophisticated automatic test routines. Using the MC44001, TV manufacturers will be able to build a standard chassis for anywhere in the world.

- Operation from a Single +5.0 V Supply; Typical Current Consumption Only 100 mA
- Full PAL/SECAM/NTSC Capability
- Dual Composite Video or S-VHS Inputs
- All Chroma/Luma Channel Filtering, and Luma Delay Line are Integrated Using Sampled Data Filters Requiring No External Components

- Filters Automatically Commutate with Change of Standard
- Chroma Delay Line is Realized with Companion Device (MC44140)
- RGB Drives Incorporate Contrast and Brightness Controls and Auto Gray Scale
- Switched RGB Inputs with Separate Saturation Control
- Auxiliary Y, R-Y, B-Y Inputs
- Line Timebase Featuring H-Phase Control and Switchable Phase Detector Gain and Time Constant
- Vertical Timebase Incorporating the Vertical Geometry Corrections
- E-W Parabola Drive Incorporating the Horizontal Geometry Corrections
- Beam Current Monitor with Breathing Compensation

4

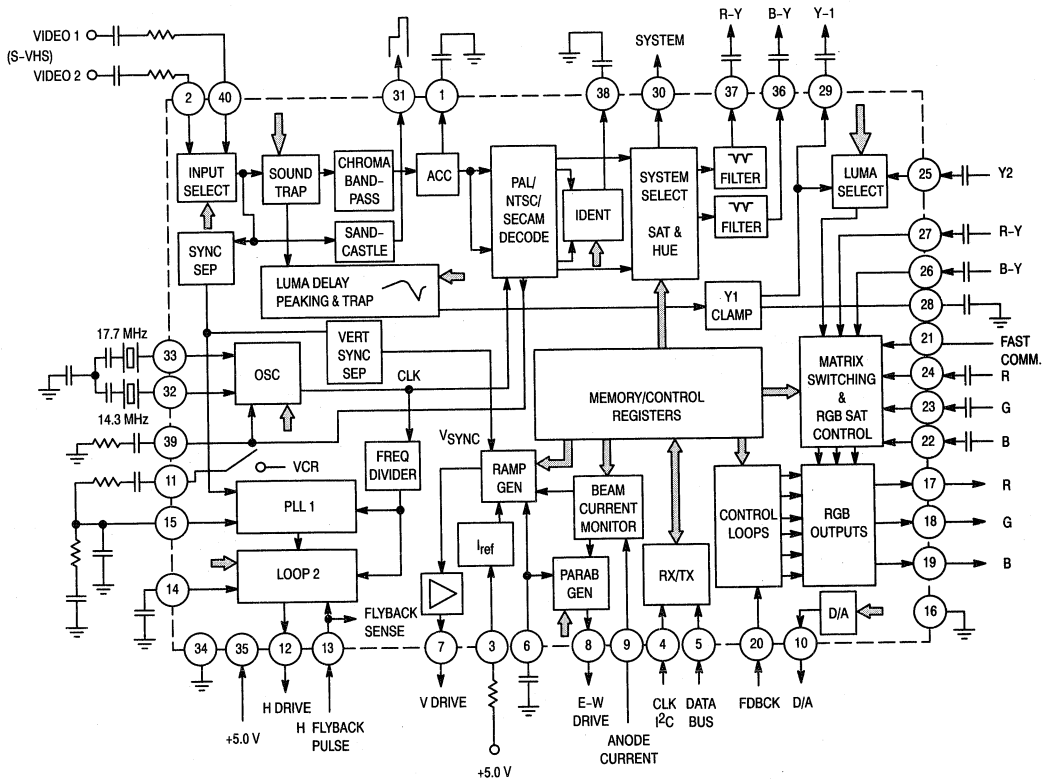

# Digitally Controlled Video Processor for Multimedia Applications

MC44011FN  
Case 777

The MC44011, a member of the MC44000 Chroma 4 family, is designed to provide RGB or YUV outputs from a variety of inputs. The inputs may be either PAL or NTSC composite video (two inputs), S-VHS, RGB, and color difference (R-Y, B-Y).

The MC44011 provides a sampling clock output for use by a subsequent analog to digital converter. The sampling clock (6.0 to 40 MHz) is phase-locked to the horizontal frequency. Additional outputs include composite sync, vertical sync, field identification, luminance, burst gate, and horizontal frequency.

Control of the MC44011, and reading of status flags is accomplished via an I<sup>2</sup>C bus.

- Multistandard Decoder, Accepts NTSC and PAL Composite Video
- Dual Composite Video or S-VHS Inputs
- All Chroma and Luma Channel Filtering, and Luma Delay Line are Integrated Using Sampled Data Filters Requiring no External components
- Digitally Controlled via I<sup>2</sup>C Bus
- Auxiliary Y, R-Y, B-Y Inputs
- Switched RGB Inputs with Separate Saturation Control
- Line-Locked Sampling Clock for Digitizing Video Signals
- Burst Gate Pulse Output for External Clamping
- Vertical Sync and Field Ident Outputs
- Software Selectable YUV or RGB Outputs Able to Drive A/D Converters

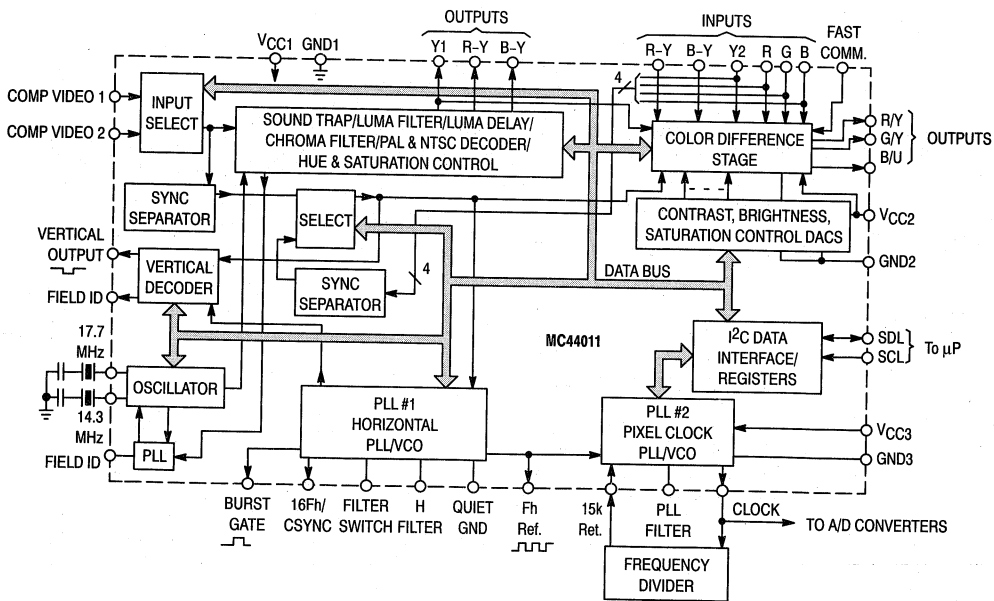

4

# TV Stereo Decoder for NICAM and German System

MC44131P  
Case 710

The MC44131 combines all of the functions necessary for the decoding and sound control in accordance with the NICAM and German Standard transmission systems. It is controlled via a microprocessor and I<sup>2</sup>C bus.

- Pilot Tone Decoding
- Baseband Stereo Signal Decoding
- Signal De-emphasis

- Direct Balance Adjustment via Software
- I<sup>2</sup>C Bus Controlled Routing of the Baseband/ Monaural/SCART Inputs to Loudspeaker/Headphone/ Hi Fi/Scart Outputs
- Loudspeaker Output Control of Tone, Special Effects, Independent Left-Right Volume Control
- Headphone Output Control of Independent Left-Right Volume Control

4

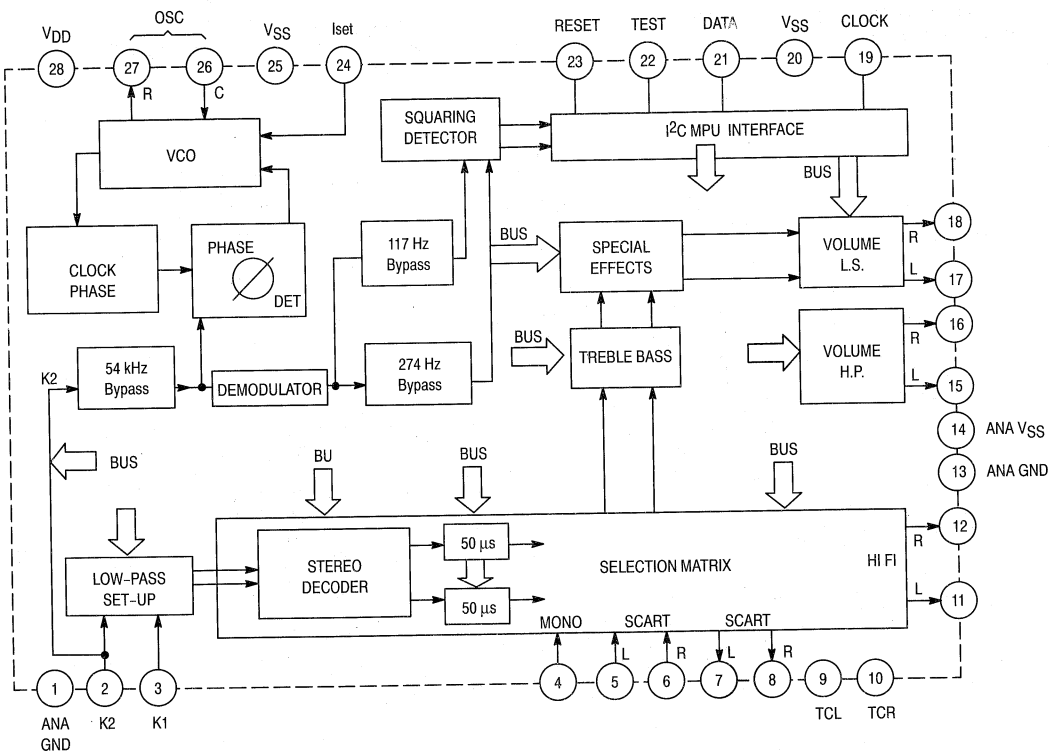

Video Circuits (continued)

## Digital Chroma Delay Line

**MC44140P, DW**  
Case 648, 751G

The MC44140 is a monolithic 64  $\mu$ s delay line, intended for color TV applications. It may be used as a baseband chroma correction circuit (with PAL), or as a chroma delay line (with SECAM). The device has been designed for use with the MC44000 as part of Chroma 4, or with the MC44011, but may also be used as a general purpose delay line for other applications.

- Part of SYSTEM 4 Concept
- Works with Baseband Color Difference Signals
- PAL (4.43 MHz)/SECAM/NTSC Capability
- Uses 17.734475 MHz Clock with PAL/SECAM Signals
- 8-Bit Sampling at 1/6 Clock Frequency
- External Inputs (Satellite ...)
- Minimum Number of External Components
- Low Current (35 mA), +5.0 V Supply

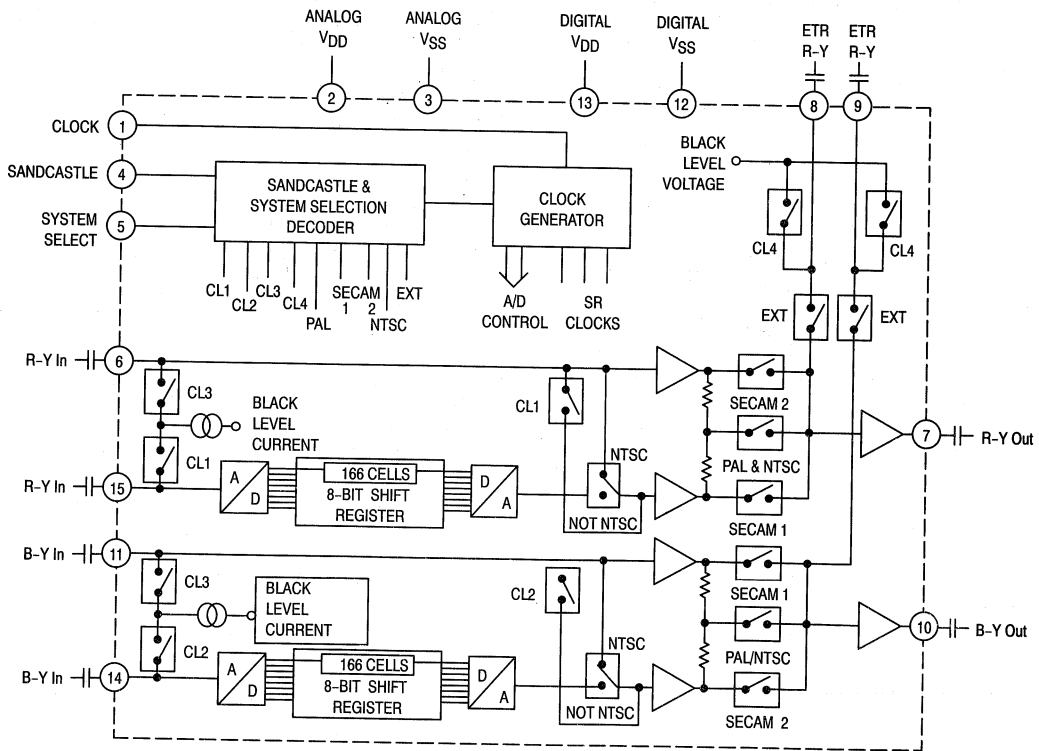

4

## Subcarrier Reference

MC44144P, D  
Case 626, 751

The MC44144 is a phase-locked-loop for video applications that provides the subcarrier frequency, and 4 times subcarrier frequency locked to the color burst. It contains, on a single chip, a phase detector, voltage controlled oscillator, divide-by-four, and video clamp.

The MC44144 is manufactured using Motorola's high density, bipolar MOSAIC® process.

- Provides 4X Frequency Locked to Color Burst
- Provides Regenerated Subcarrier Output
- 5.0 V Operation

4

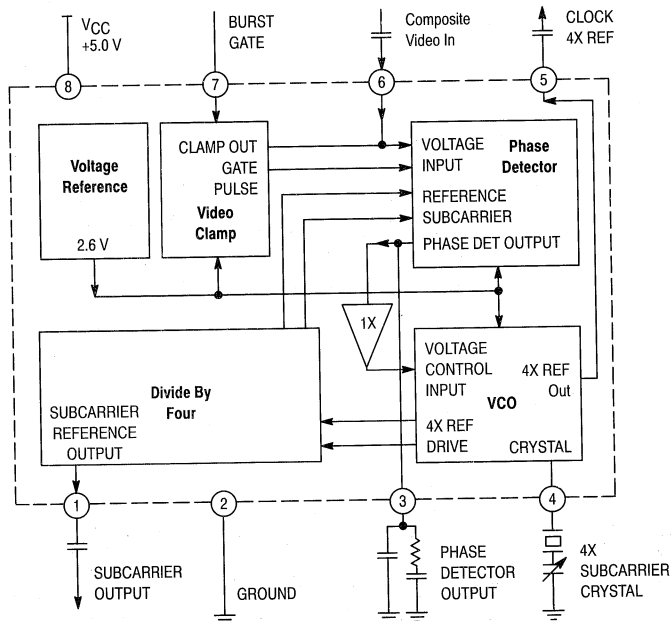

## Video Circuits (continued)

# Pixel Clock Generator and Sync Separator

MC44145D

Case 751A

The MC44145 Pixel Clock Generator is a component of the M44000 family. This device contains a sync separator with horizontal and vertical outputs, and clock generation circuitry for the digitization of any video signal, along with the necessary circuitry for clock generation such as a phase comparator and a  $\div 2$  to provide a 50% duty cycle.

- Stand Alone PLL Circuit
- Switchable Divider for 50% Duty Cycle
- Integrated Sync Separator
- Integrated Buffer Amplifier

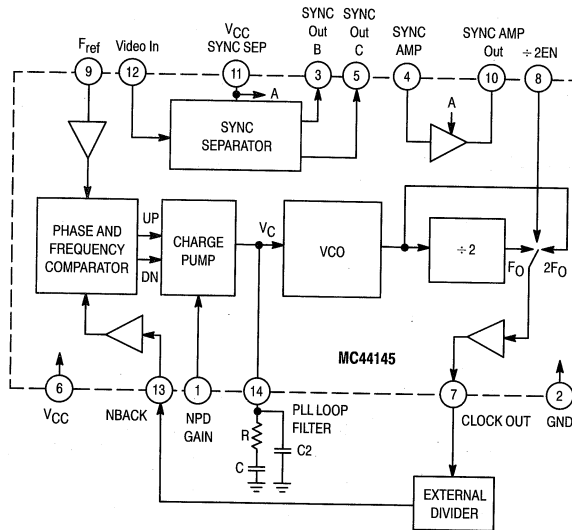

4

## Triple 8-Bit D/A Converter

MC44200FU

Case 824A

The MC44200 is a monolithic digital to analog converter for three independent channels fabricated in CMOS technology. The part is specifically designed for video applications. Differential outputs are provided, allowing for a large output voltage range.

- 8-Bit Resolution
- Differential Outputs
- 80 msp/s Conversion Speed
- Large Output Voltage Range
- Low Current Mode
- Single 5.0 V Power Supply
- TTL Compatible Inputs
- Integrated Reference Voltage

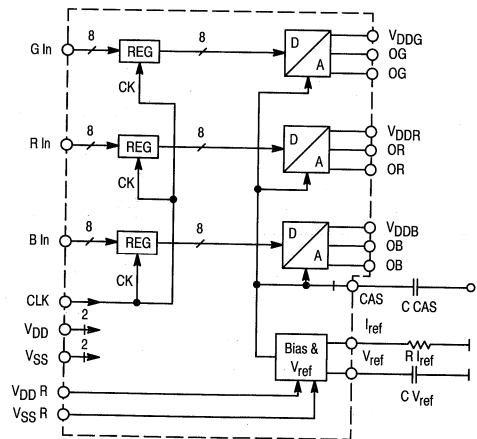



## Triple 8-Bit A/D Converter

MC44250/51FN  
Case 777

The MC44250 and MC44251 contain three independent parallel analog to digital converters. Each ADC consists of 256 latching comparators and an encoder. Input clamps allow for AC coupling of the input signals, and DC coupling is also allowed. For video processing performance enhancements, a dither generator with subsequent digital correction is provided to each ADC. The outputs of the MC44251 can be set to a high impedance state.

These A/Ds are especially suitable as front end converters in TV picture processing.

- 15 MHz Maximum Conversion Speed (MC44250)
- 18 MHz Maximum Conversion Speed (MC44251)
- Input Clamps Suitable for RGB and YUV Applications
- Built-in Dither Generator with Subsequent Digital Correction
- Single 5.0 V Power Supply

4

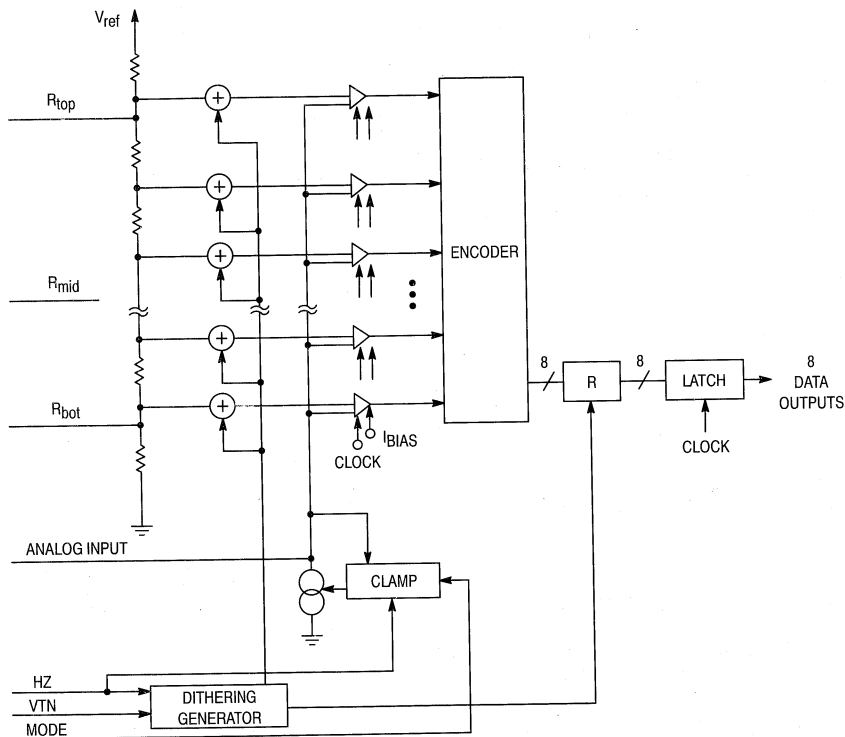

Simplified Diagram of One of the ADCs

## Video Circuits (continued)

### Multistandard Video IF

MC44301P, DW

Case 724, 751F

The MC44301 is a single channel TV IF and PLL detector system for all standard transmission systems. This device enables the designer to produce a high quality IF system with white spot inversion, AFT and AGC. The MC44301 was designed with an emphasis on linearity to minimize sound/picture intermodulation.

- Single Coil Adjustment for AFT and PLL
- VCO at 1/2 IF for Minimum Beats
- Simple Circuitry for Low System Cost
- White Spot Inversion
- Symmetrical  $\pm 2.0$  MHz AFT Pull-In
- Demodulates Positive or Negative Modulation
- Auxiliary AM Detector for AM Sound
- Simple Alignment Procedure

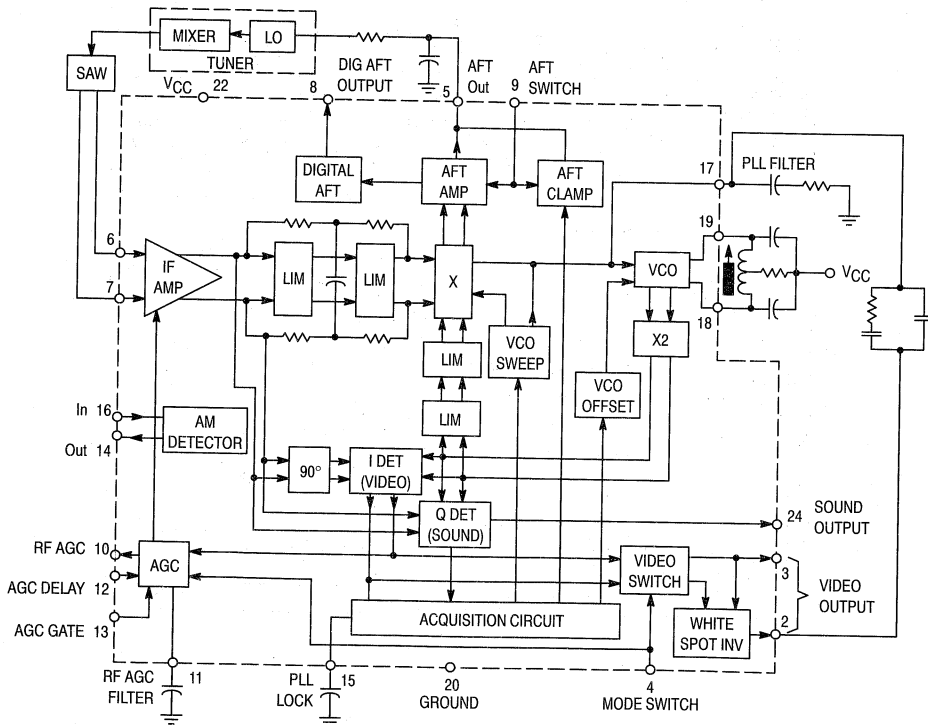

4

**Video Circuits (continued)**

# 1.3 GHz Tuner PLL with I<sup>2</sup>C Control

**MC44802AP**

Case 707

The MC44802A is a tuning circuit for TV applications. It contains, on one chip, all the functions required for PLL control of a VCO. This integrated circuit also contains a high frequency prescaler (which can be bypassed by software control) and thus handle frequencies up to 1.3 GHz.

- Complete Single Chip System for MPU Control (I<sup>2</sup>C Bus)
- Selectable ÷ 8 Prescaler Accepts Frequencies Up to 1.3 GHz

- Programmable Reference Divider
- Tri State Phase/Frequency Comparator
- Op Amp for Direct Tuning Voltage Output: 30 V
- Seven High Current Buffers: 10 mA, 12 V
- Output Options for 62.5 kHz, Reference Frequency and the Programmable Divider
- Software Compatible with the MC44810
- I<sup>2</sup>C Interface

**4**

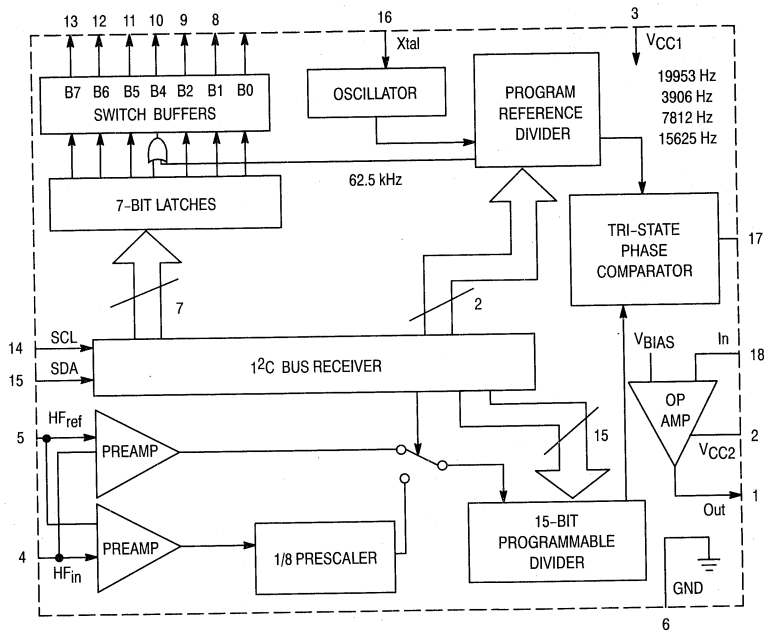

## Video Circuits (continued)

### 1.3 GHz Tuner PLL with 3-Wire Control

MC44807P/17D

Case 648, 751B

The MC44807/17 is a tuning circuit for TV applications. It contains, on one chip, all the functions required for PLL control of a VCO. This integrated circuit also contains a high frequency prescaler (which can be bypassed by software control) and thus handle frequencies up to 1.3 GHz.

- Complete Single Chip System for MPU Control (3-Wire Bus)
- ÷ 8 Prescaler Accepts Frequencies Up to 1.3 GHz
- 15-Bit Programmable Reference Divider Accepts Frequencies Up to 165 MHz

- Tri-State Phase/Frequency Comparator with Lock Detect Output
- Op Amp for Direct Tuning Voltage Output: 30 V
- Four Integrated Band Buffers for 40 mA ( $V_{CC1}$  to 14.4 V)
- Output Options for Reference Frequency and Programmable Divider
- Bus Protocol for 18 or 19-Bit Transmission
- High Input Sensitivity

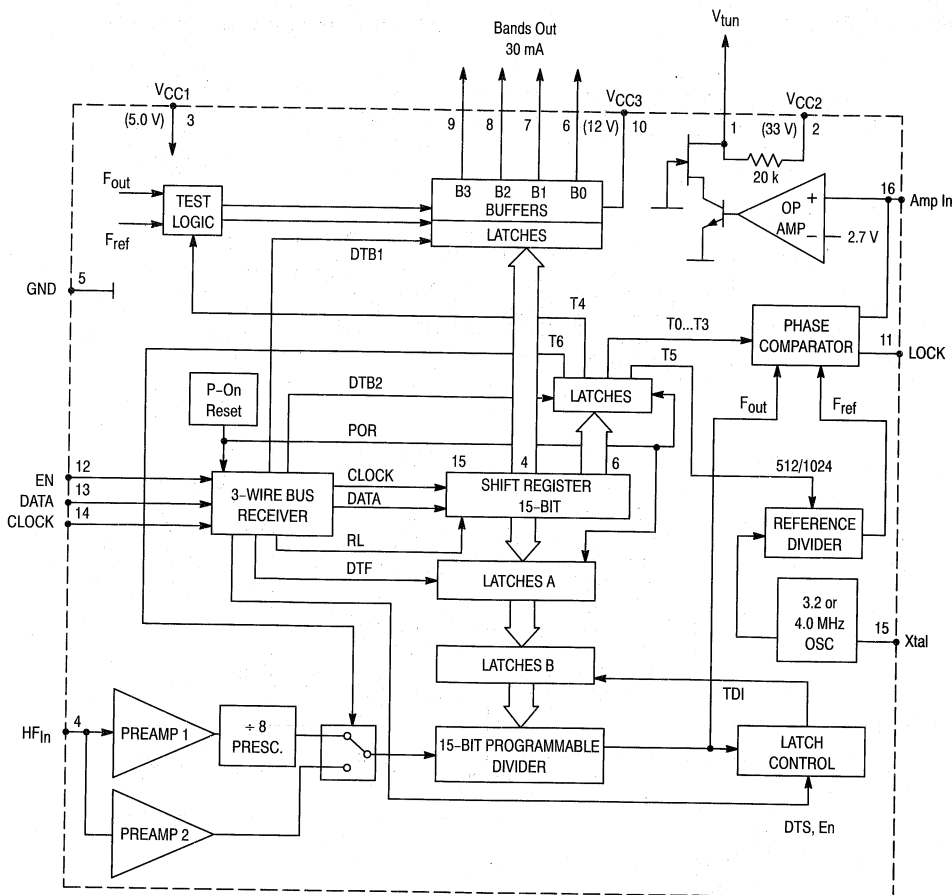

## PLL Tuning Circuit with DACs for Tuner Alignment

**MC44810P**  
Case 738

The MC44810 is a tuning circuit for TV applications. It contains a PLL section and a DAC section and is MPU controlled through the I<sup>2</sup>C bus.

The PLL section contains all the functions required to control the VCO of a TV tuner. It generates the tuning voltage and the additional control signals. The PLL section is functionally equivalent to the MC44802A.

The DAC section generates three varactor voltages in order to feed all of the tuner varactors with their individually optimized control voltages (automatic tuner adjustment).

- Complete Single Chip System for MPU Control (I<sup>2</sup>C Bus)
- Tri-State Phase/Frequency Comparator

- Selectable ÷ 8 Prescaler Accepts Frequencies Up to 1.3 GHz
- 15-Bit Programmable Reference Divider Accepts Frequencies Up to 165 MHz
- Op Amp for Direct Tuning Voltage Output: 30 V
- Seven High Current Buffers: 10 mA, 12 V
- Output Options for 62.5 kHz, Reference Frequency and Programmable Divider
- Software Compatible with the MC44802A
- Three 6-Bit DACs for Automatic Tuner Adjustment Allowing Use of Non-Matched Varactors
- 2 Chip Addresses for the PLL Section and 2 Different Chip Addresses for the DAC Section

4

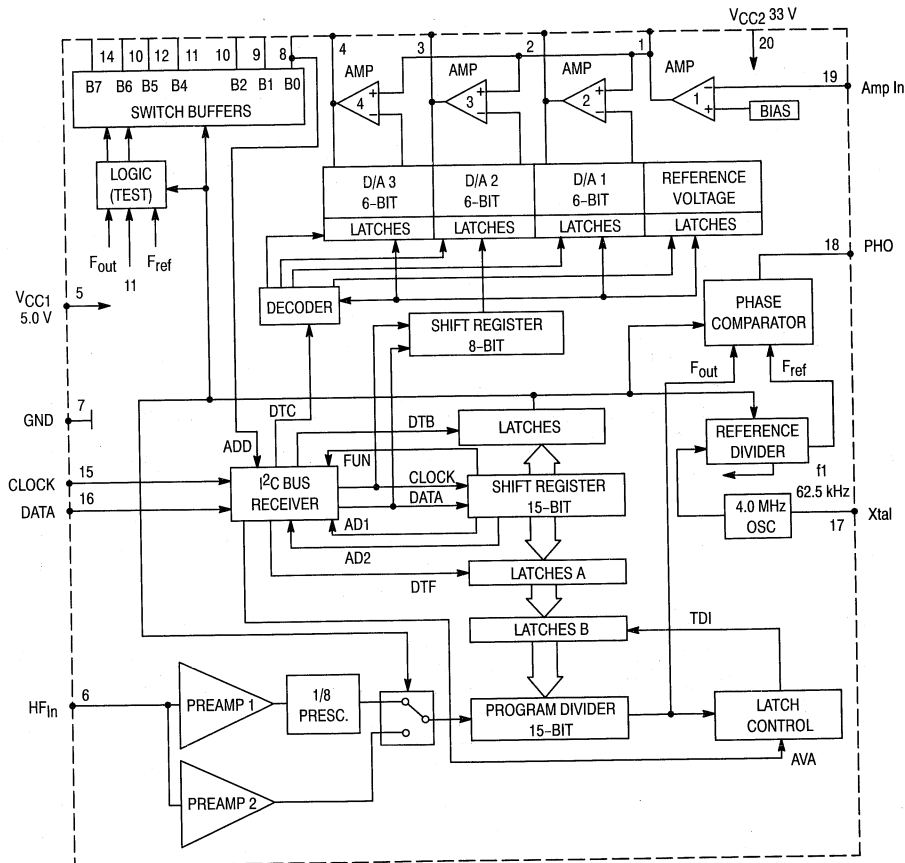

## Video Circuits (continued)

# Closed-Caption Decoder

MC144143P

Case 707

The MC144143 is a Line 21 closed-caption decoder for use in television receivers or set top decoders conforming to the NTSC broadcast standard. Capability for processing and displaying all of the latest standard Line 21 closed-caption format transmissions is included. The device requires a closed-caption encoded composite video signal, a horizontal sync signal, and an external keyer to produce captioned video. RGB outputs are provided, along with a luminance and a box signal, allowing simple interface to both color and black and white receivers.

- Conforms to the SCC Report and Order as Amended by the Petition for Reconsideration on Gen. Doc. 91-1
- Supports Four Different Data Channels, Time Multiplexed within the Line 21 Data Stream: Captions Utilizing Languages 1 & 2, Plus Text Utilizing Languages 1 & 2
- Output Logic Provides Hardware Underline Control and Italics Slant Generation
- Single Supply Operating Voltage Range: 4.75 to 5.25 V
- Composite Video Input Range: 0.7 to 1.4 V<sub>p-p</sub>
- Horizontal Sync Input Polarity can be either Positive or Negative
- Internal Timing/Sync Signals Derived from On-Chip VCO

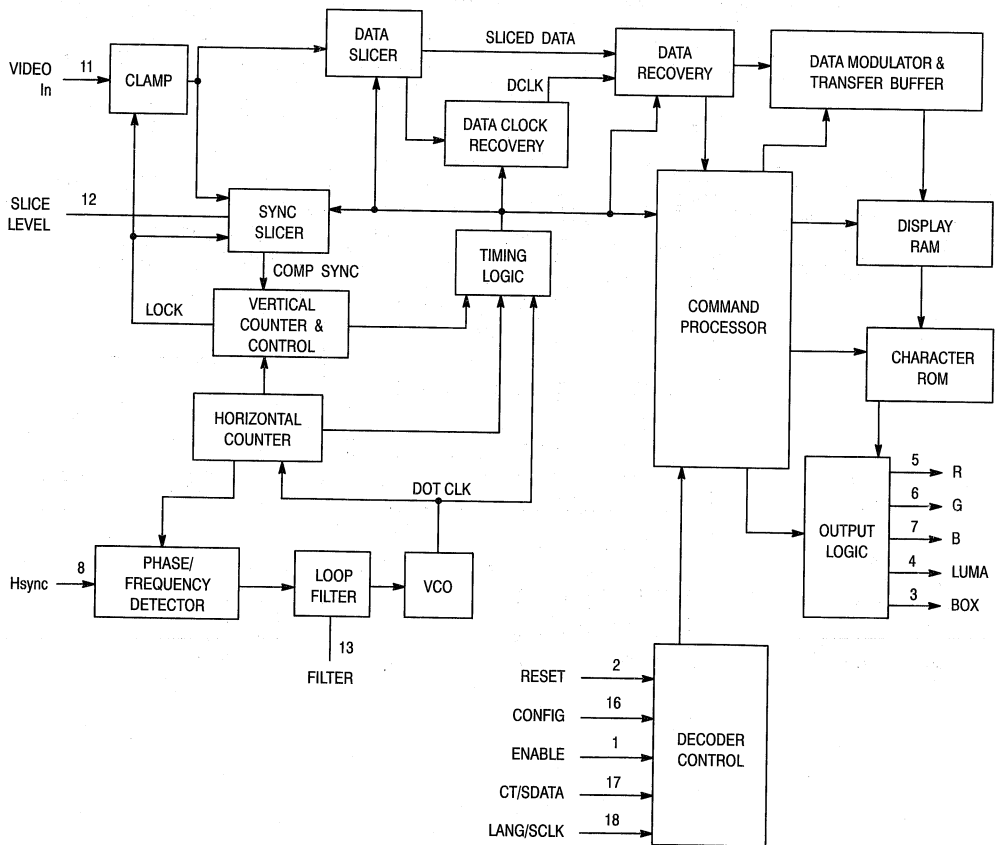

4

## Advanced NTSC Comb Filter

MC141621FU

Case 898

The MC141621 is an advanced NTSC comb filter for VCR and TV applications. It separates the luminance (Y) and chrominance (C) signals from the NTSC composite video signal by using digital signal processing techniques. This filter allows a video signal input of an extended frequency bandwidth by using a 4.0 F<sub>SC</sub> clock. In addition, the filter minimizes dot crawl and cross color effects. The built-in A/D and D/A converters allow easy connections to analog video circuits.

- Built-in High Speed 8-Bit A/D Converter
- Two Line Memories (1820 Bytes)
- Advanced Combining Process
- Two 8-Bit D/A Converters
- Built-in Clamp Circuit
- On-Chip Reference Voltage Regulator for ADC
- Digital Interface Mode

4

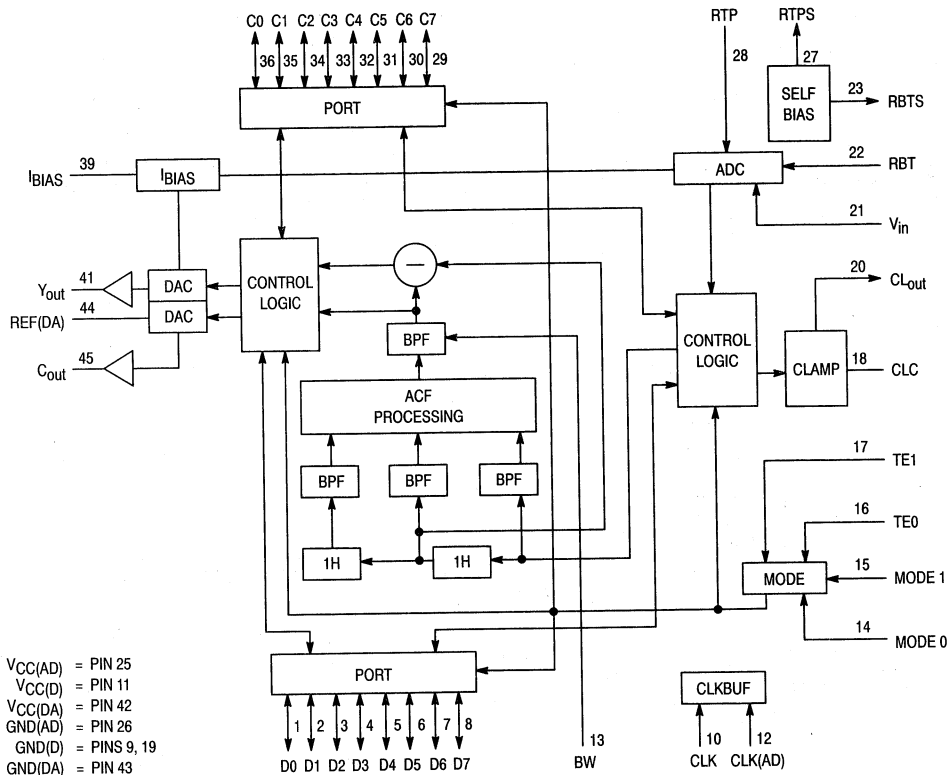

## Video Circuits (continued)

# Advanced PAL/NTSC Comb Filter

MC141625AFU, FU

Case 898

The MC141625 is an advanced PAL/NTSC comb filter for VCR and TV applications. It separates the luminance (Y) and chrominance (C) signals from the PAL or NTSC composite video signal by using digital signal processing techniques. This filter allows a video signal input of an extended frequency bandwidth and minimizes dot crawl and cross color effects. The built-in A/D and D/A converters allow easy connections to analog video circuits.

- Fast 8-Bit A/D Converter
- Four Line Memories (4540 Bytes)
- Advanced Combing Process
- Two 8-Bit D/A Converters
- Built-in Clamp Circuit
- On-Chip Reference Voltage Regulator for ADC
- Digital Interface Mode
- PAL/NTSC Mode

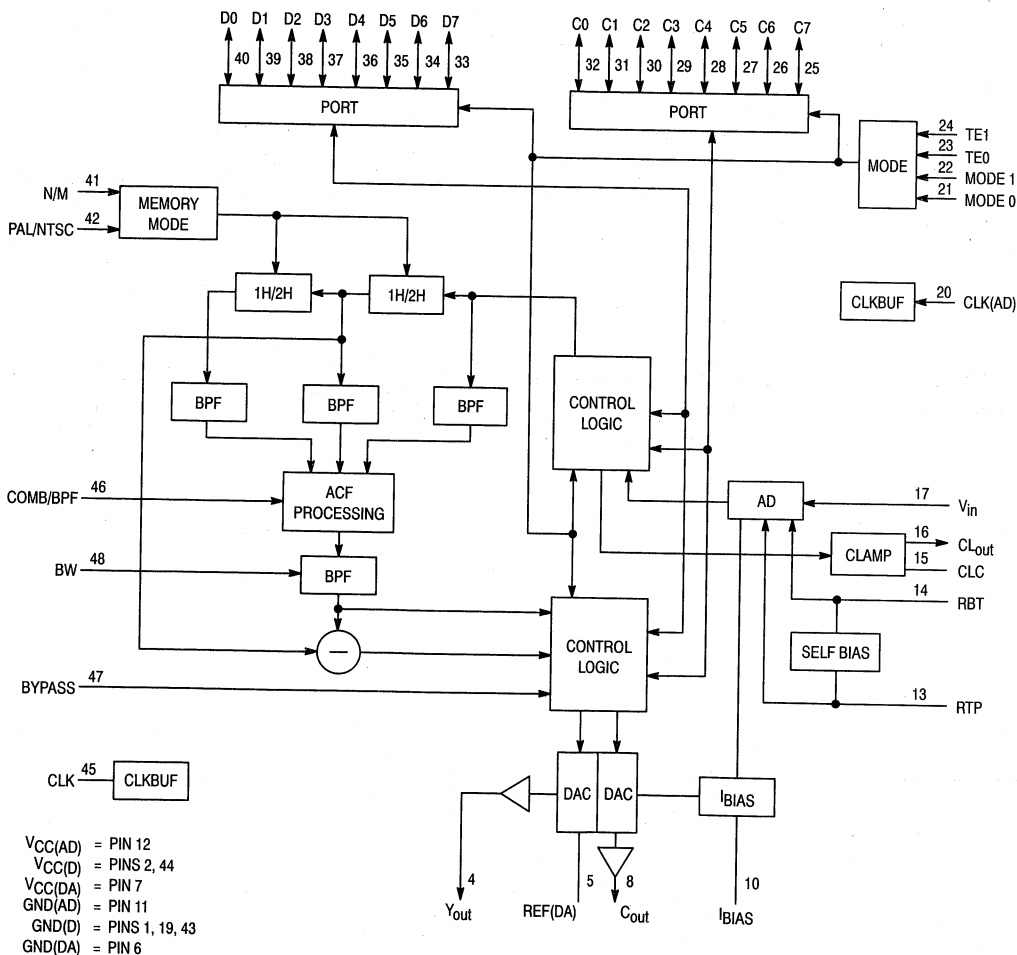

4



## Dual Video Amplifiers

### MC14576B/77BF, P

Case 626, 904

The MC14576B/77B devices each contain two amplifiers manufactured in CMOS process. Each amplifier also employs two lateral NPN bipolar transistors.

The MC14576B contains two internally compensated operational amplifiers. On-chip gain setting resistors result in a noninverting voltage gain of 6.0 dB,  $\pm 1.0$  dB at 4.43 MHz for each amp. Each noninverting input of the MC14576B appears as mostly a capacitive load of approximately 10 pF.

The MC14577B also contains two internally compensated operational amplifiers. However, the gain for each amplifier is adjustable with external components. All inputs of the MC14577B appear mostly as capacitive loads of approximately 10 pF.

- Direct Drive of 150  $\Omega$  Loads
- May Be Used with Single or Dual Supplies
- Guaranteed Bandwidth of 10 MHz

4

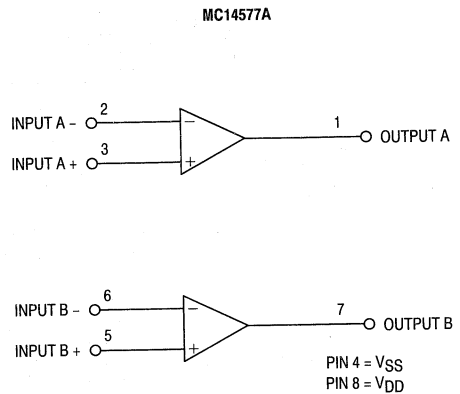
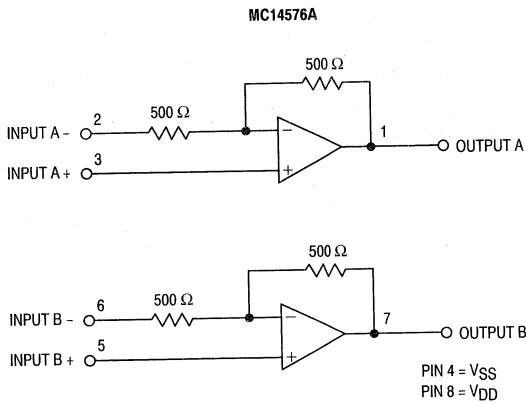

# Remote Control Circuits

**MC3373P Amplifier/Detector (Bipolar)**  
Case 626

**MC14497 Transmitter (CMOS)**  
Case 707

The MC3373 remote control receiver is specifically designed for infrared link systems where high sensitivity and good noise immunity are critical. The MC3373 incorporates a high gain detector diode preamp driving an envelope detector and data wave shaper for accurate data recovery. Provision is also made to use an external L-C tank circuit at the carrier frequency, normally 30 to 60 kHz, for extended range low

noise systems. Applications include TV remote control, short range data links (up to several hundred feet), door openers and security systems. The MC14497 is an ideal companion transmitter, where a simple DTMF like key-pad control is desired. The Motorola Discrete Opto Division also has several high sensitivity detectors and emitters which match up well to the MC3373 system.

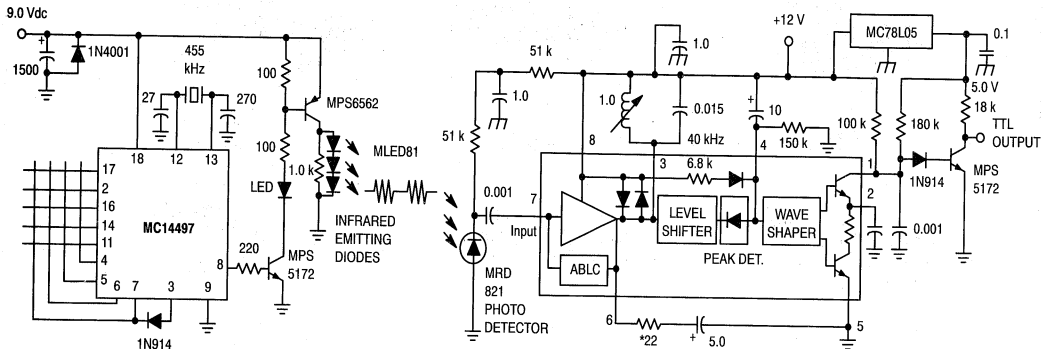

Figure 4. Remote Control Application 40 kHz Carrier

4

Table 60. CMOS Remote Control Functions

Function	Number of Address Lines	Maximum Number of Address Codes	Number of Data Bits	Operation	Device	Suffix/Package
Addressable UART	7	128	7/8	Full-Duplex	MC14469	P/711, FN/777
Transmitter	0	0	6	Simplex	MC14497	P/707
Encoder	Depends on Decoder(1)	Depends on Decoder(1)	Depends on Decoder(1)	Simplex	MC145026	P/648, D/751B
Decoder	5	243	4	Simplex	MC145027	P/648, DW/751G
	9	19,683	0	Simplex	MC145028	
Encoder/Decoder	9	512	0	Half-Duplex	MC145030	P/738, DW/751D
	15	32,768	0	Half-Duplex	MC145033	
Encoder	13 or 17	131,072	4	Simplex	MC145034	DW/751F
Decoder	13 or 17	131,072	4	Simplex	MC145035	

(1) See MC145027, MC145028.

# Consumer Electronic Circuits Package Overview

4

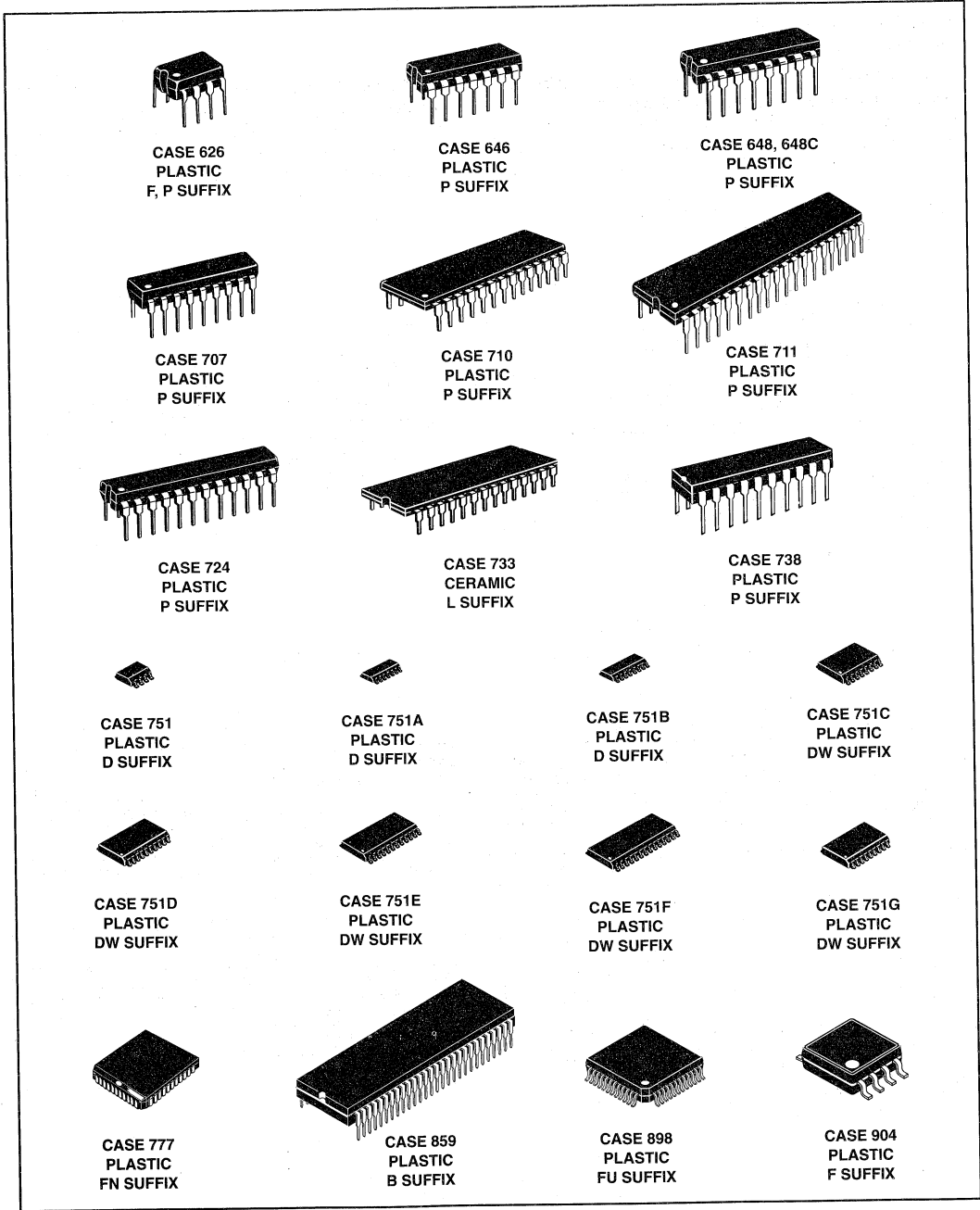

# Automotive Electronic Circuits

---

## In Brief . . .

Motorola Linear has established itself as a global leader in custom integrated circuits for the automotive market. With multiple design centers located on four continents, global process and assembly sites, and strategically located supply centers, Motorola serves the global automotive market needs. These products are key elements in the rapidly growing engine control, body, navigation, entertainment, and communication electronics portions of modern automobiles. Though Motorola is most active in supplying automotive custom designs, many of yesterday's proprietary custom devices become standard products of today available to the broad base manufactures who support this industry. Today, based on new technologies, Motorola offers a wide array of standard products ranging from rugged high current "smart" fuel injector drivers which control and protect the fuel management system, through rigors of the underhood environment, to the latest SMARTMOS™ switches and series transient protectors. Several devices are targeted to support microprocessor housekeeping and data line protection. A wide range of packaging is available from die, flip-chip, and SOICs for high density layouts, to low thermal resistance multi-pin, single-in-line types for high power control ICs.

	<b>Page</b>
Voltage Regulators .....	4.9-2
Electronic Ignition .....	4.9-2
Special Functions .....	4.9-3

# Automotive Electronic Circuits

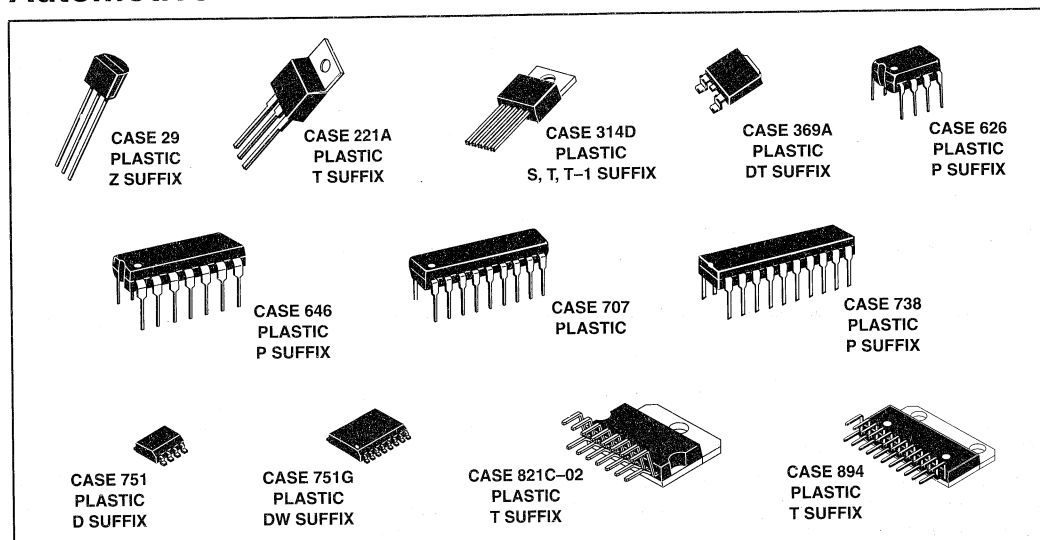

4

**Table 61. Voltage Regulators**

Function	Features	Suffix/ Package	Device
Low Dropout Voltage Regulator	Positive fixed and adjustable output voltage regulators which maintain regulation with very low input to output voltage differential.	Z/29, T/221A, T/314D, DT/369A	LM2931,C
Low Dropout Dual Regulator	Positive low voltage differential regulator which features dual 5.0 V outputs, with currents in excess of 750 mA (switched) and 10 mA standby, and quiescent current less than 3.0 mA.	T/314D	LM2935
Automotive Voltage Regulator	Provides load response control, duty cycle limiting, under/overvoltage and phase detection, high side MOSFET field control, voltage regulation in 12 V alternator systems.	DW/751D	MC33092
Low Dropout Voltage Regulator	Positive 5.0 V, 500 mA regulator having on-chip power-up-reset circuit with programmable delay, current limit, and thermal shutdown.	T/314	MC33267

**Table 62. Electronic Ignition**

Function	Features	Suffix/ Package	Device
Electronic Ignition Circuit	Used in high energy variable dwell electronic ignition systems with variable reluctance sensors. Dwell and spark energy are externally adjustable.	P/626, D/751	MC3334
Flip-Chip Electronic Ignition Circuit	Same as MC3334 — Mirror image die for inverted "bumped" mounting to substrate	Flip-Chip	MCCF3334
Flip-Chip Electronic Ignition Control Chip	Used in high energy electronic ignition systems requiring differential Hall Sensor control. "Bumped" die for inverted mounting to substrate.	Flip-Chip	MCCF33093
Flip-Chip Electronic Ignition Control Circuit	Used in high energy electronic ignition systems requiring single Hall Sensor control. "Bumped" die for inverted mounting to substrate.	Flip-Chip	MCCF33094
Flip-Chip Electronic Ignition Control Circuit	Used in high energy electronic ignition systems requiring single Hall Sensor control. Dwell feedback for coil variation. "Bumped" die for inverted mounting to substrate.	Flip-Chip	MCCF79076

**Table 63. Special Functions**

Function	Features	Suffix/ Package	Device
Low Side Protected Switch	Single automotive low side switch having CMOS compatible input, 1.0 A maximum rating, with overcurrent, overvoltage, and thermal protection.	T/221, T-1/314D, DW/751G	MC3392
High Side Driver Switch	Drives loads from positive side of power supply and protects against high-voltage transients.	T/314D	MC3399
High Side T MOS Driver	Designed to drive and protect N-channel power MOSFETs used in high side switching applications. Has internal charge pump, externally programmed timer, and fault reporting.	P/626, D/751	MC33091
MI-Bus Interface Stepper Motor Controller	High noise immunity serial communication using MI-Bus protocol to control relay drivers and motors in harsh environments. Four phase signals drive two phase motors in either half or full-step modes.	DW/751G	MC33192
Quad Fuel Injector Driver	Four low side switches with parallel CMOS compatible input control, $\leq 7.0$ mA quiescent current, $0.25 \Omega r_{ds(on)}$ at $25^\circ\text{C}$ independent outputs with 3.0 A current limiting and internal 65 V clamps.	T/821C-02	MC33293
Quad Fuel Injector Driver	Four low side switches with parallel CMOS compatible input control, $\leq 5.0$ mA quiescent current, $0.7 \Omega r_{ds(on)}$ at $25^\circ\text{C}$ independent outputs with 3.0 A current limiting and internal 65 V clamps.	T/821C-02	MC33295
Octal Serial Output Switch	Eight low side switches having 8-bit serial CMOS compatible input control, serial fault reporting, $\leq 4.0$ mA quiescent current, independent $0.45 \Omega r_{ds(on)}$ at $25^\circ\text{C}$ outputs with 3.0 A minimum current limiting and internal 55 V clamps.	P/738	MC33298
Integral Alternator Regulator	Control device used in conjunction with an MCCF33096 Darlington companion device to monitor and control the field current in alternator charging systems. "Bumped" die for inverted mounting to substrate.	Flip-Chip	MCCF33095
Darlington Drive Chip	Darlington companion device for MC33095 used to control the field current in alternator charging systems. "Bumped" die for inverted mounting to substrate.	Flip-Chip	MCCF33096
Peripheral Clamping Array	Protects up to six MPU I/O lines against voltage transients.	D/751	TCF6000
Automotive Direction Indicator	Detects defective lamps and protects against overvoltage and short circuit hazards in automotive turn-signal applications. Replaces UAA1041 with improved noise immunity.	P/626, D/751	UAA1041B

4

# Quad Fuel Injector Driver

MC33293T

$T_J = -40^\circ$  to  $+150^\circ\text{C}$ , Case 821C

The MC33293T is a monolithic quad low-side switching device having CMOS logic, bipolar/CMOS analog circuitry, and DMOS power FETs. All inputs are CMOS compatible. Each independent output is internally clamped to 65 V, current limited to  $\geq 3.0$  A, and has an  $r_{ds(on)}$  of  $\leq 0.25 \Omega$  with  $V_{PWR} \geq 9.0$  V and may be paralleled to lower  $r_{ds(on)}$ . Fault output reports existence of open loads (outputs On or Off), shorted

loads, and over temperature condition of outputs. A shorted load condition will shut off only the specific output involved while allowing other outputs to operate normally. An overvoltage condition will shut off all outputs for the overvoltage duration. A single/dual mode select pin allows either independent input/output operation or paired output operation.

4

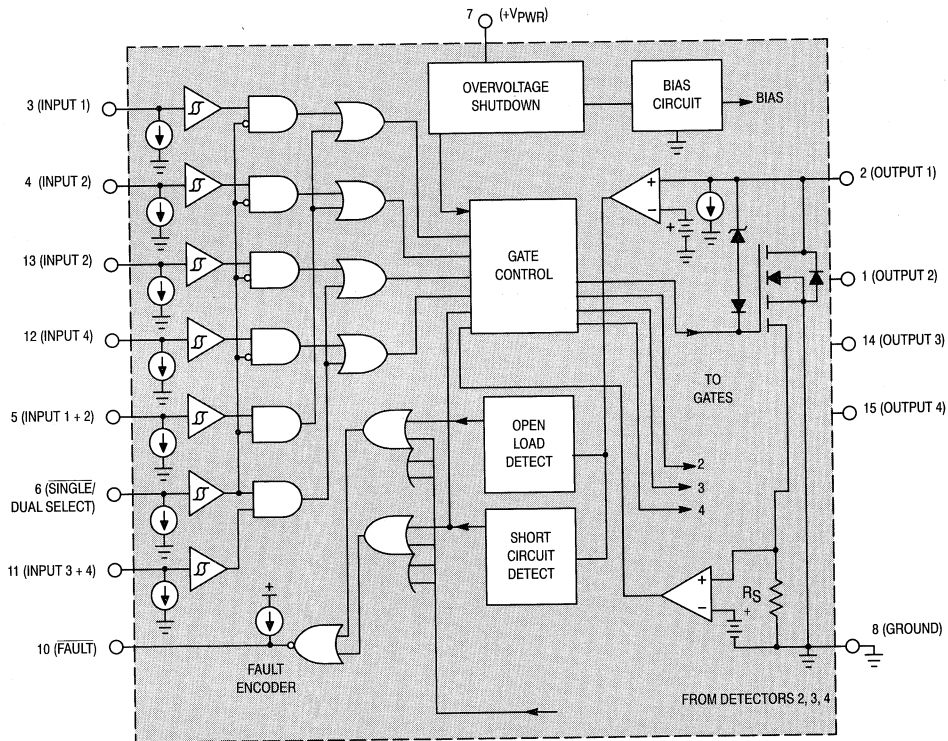

# Octal Serial Switch

## MC33298P

$T_J = -40^\circ$  to  $+150^\circ\text{C}$ , Case 738

The MC33298P is a monolithic eight output low-side switch with 8-bit serial input control. Incorporates CMOS logic, bipolar/CMOS analog circuitry, and DMOS power FETs. All inputs are CMOS compatible. It is designed to interface to a microcontroller and switch inductive or incandescent loads.

Each independent output is internally clamped to 55 V, current limited to  $\geq 3.0$  A, and has an  $r_{ds(on)}$  of  $\leq 0.45 \Omega$  with  $V_{PWR} \geq 9.0$  V. This device has low standby current, cascadable fault status reporting, output diagnostics, and shutdown for each output.

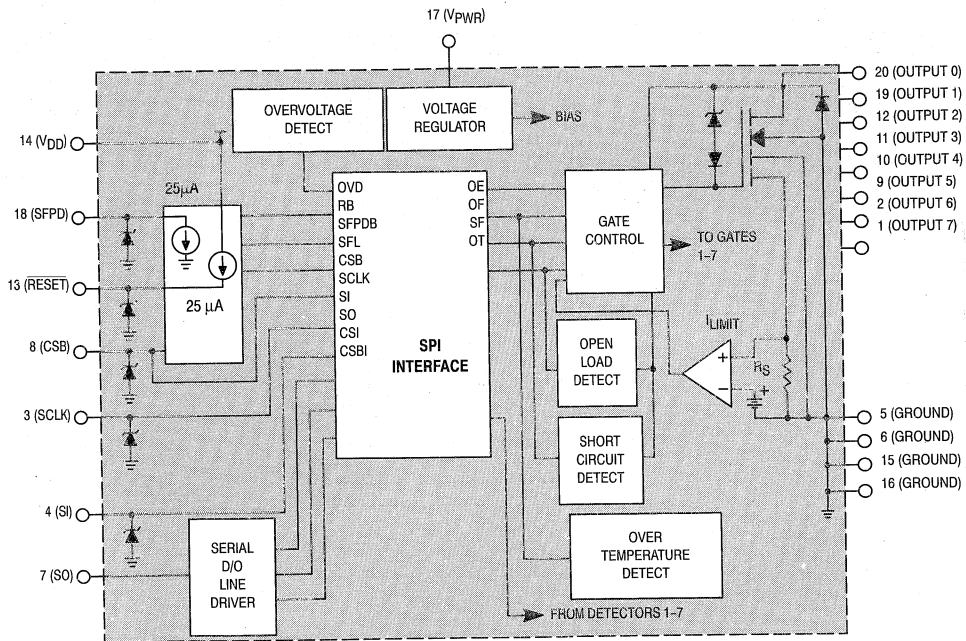

4



# Low Side Protected Switch

MC3392T, T-1,DW

$T_J = -40^\circ$  to  $+150^\circ\text{C}$ ,  
Case 221A, 314D, 751G

Single low side protected switch with fault reporting capability. Input is CMOS compatible. Output is short circuit protected to 1.0 A minimum with a unique current fold-back feature. Device has internal output clamp for driving inductive loads with over current, overvoltage, and thermal protection. When driving a moderate

load, the MC3392 performs as an extremely high gain, low saturation Darlington transistor having a CMOS input characteristic with added protection features. In some applications, the three terminal version can replace industry standard TIP100/101 NPN power Darlington transistors.

4

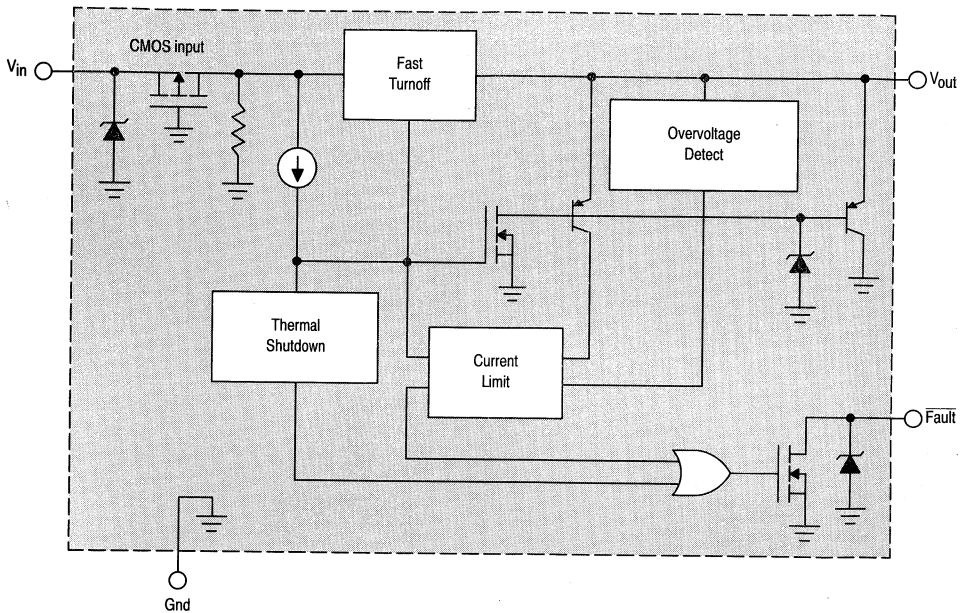

# High Side TMOS Driver

## MC33091P, D

$T_J = -40^\circ$  to  $+150^\circ\text{C}$ , Case 626, 751

Offers an economical solution to drive and protect N-channel power TMOS devices used in high side switching configurations. Unique device monitors load resulting  $V_{DS}$ -TMOS voltage to produce a proportional current used to drive an externally programmed over current timer circuit to protect the TMOS device from shorted load conditions. Timer can be programmed to accommodate driving incandescent loads.

Few external components required to drive a wide variety of N-channel TMOS devices. A  $\overline{\text{Fault}}$  output is made available through the use of an open collector NPN transistor requiring a single pull-up resistor for operation. Input is CMOS compatible. Device uses  $\leq 3.0 \mu\text{A}$  standby current and has an internal charge pump requiring no external components for operation.

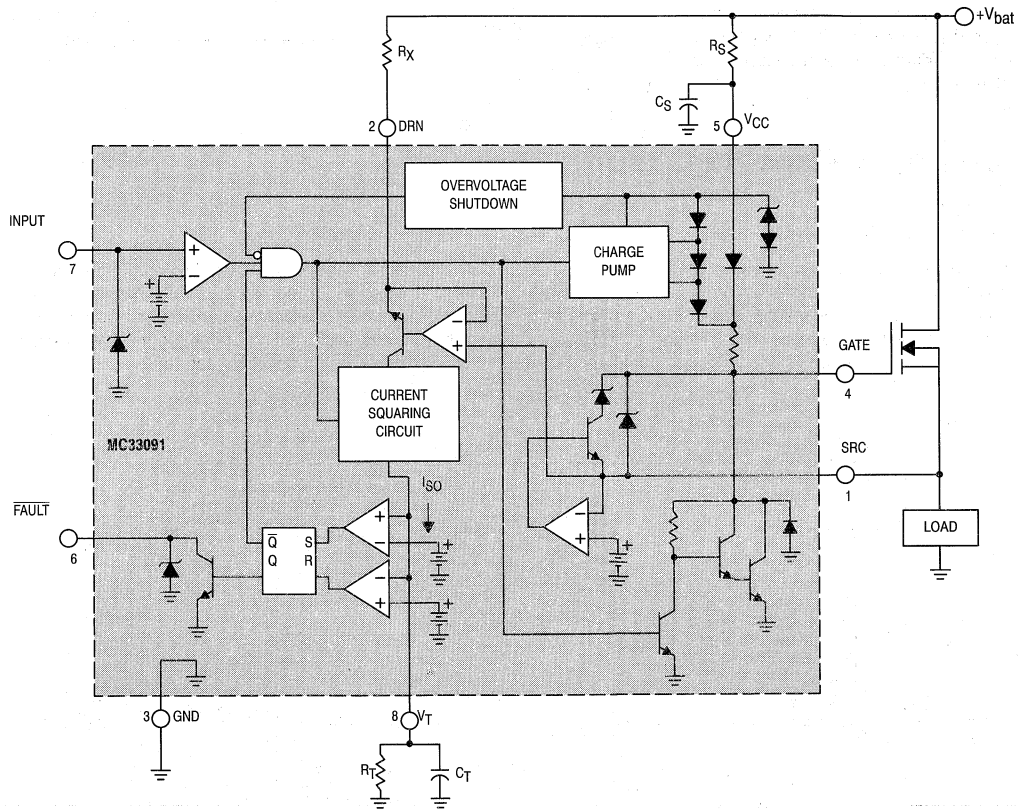

4

# MI-Bus Interface Stepper Motor Controller

## MC33192DW

$T_J = -40^\circ$  to  $+100^\circ\text{C}$ , Case 751G

Intended to control loads in harsh automotive environments using a serial communication bus. Can provide satisfactory real time control of up to eight stepper motors using MI-Bus protocol. Use of MI-Bus offers a noise immune system solution for difficult applications involving relays and motors. The stepper motor controller provides four phase signals to drive two phase motors in either half of full-step modes. Designed to interface to a microprocessor with minimal amount of wiring, affording an economical and versatile system.

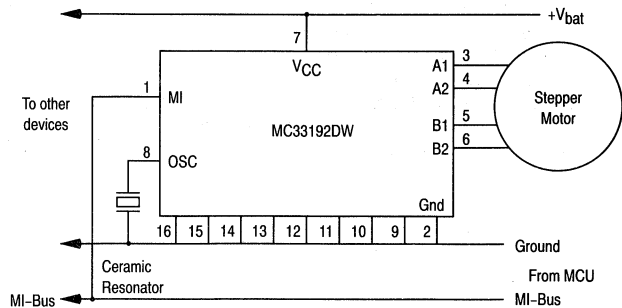

# Alternator Voltage Regulator

## MC33092DW

$T_J = -40^\circ$  to  $+125^\circ\text{C}$ , Case 751D

Provides voltage regulation and load response control in diode rectified 12 V alternator charging systems. Provides externally programmed load response control of the alternator output current to eliminate engine speed hunting and vibration due to sudden electrical loads. Monitors and compares the

system battery voltage to an externally programmed set point value and pulse width modulates an N-channel MOSFET transistor to control the average alternator field current. In addition, has duty cycle limiting, under/overvoltage and phase detection (broken belt) protective features.

4

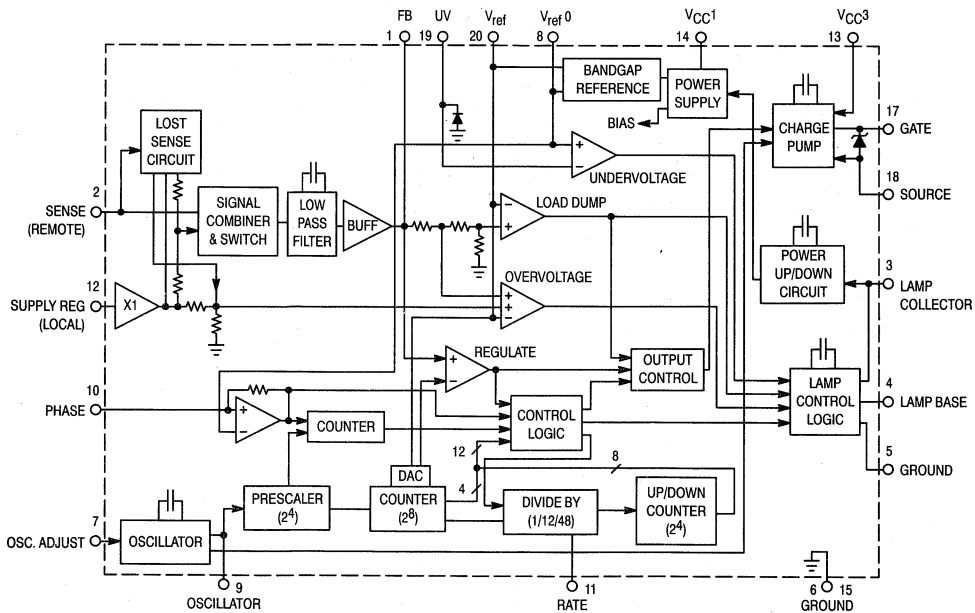

# Other Linear Circuits

---

## In Brief . . .

A variety of other analog circuits are provided for special applications with both bipolar and CMOS technologies. These circuits range from the industry standard analog timing circuits and multipliers to specialized CMOS smoke detectors. These products provide key functions in a wide range of applications, including data transmission, commercial smoke detectors, and various industrial controls.

	Page
Timing Circuits	
Singles .....	4.10-2
Duals .....	4.10-2
Multipliers .....	4.10-2
Smoke Detectors (CMOS) .....	4.10-3
Package Overview .....	4.10-4



## Timing Circuits

These highly stable timers are capable of producing accurate time delays or oscillation. In the time delay mode of operation, the time is precisely controlled by one external resistor and capacitor. For a stable operation as an oscillator, the free-running frequency and the duty cycle are both accurately controlled with two external resistors and one capacitor. The output structure can source or sink up to 200 mA or drive TTL circuits. Timing intervals from microseconds through hours can be obtained. Additional terminals are provided for triggering or resetting if desired.

## Singles

### MC1455P1,U,D

$T_A = 0^\circ$  to  $+70^\circ\text{C}$ , Case 626, 693, 751

### MC1455BP1

$T_A = -40^\circ$  to  $+85^\circ\text{C}$ , Case 626

## Duals

### MC3456L,P

$T_A = 0^\circ$  to  $+70^\circ\text{C}$ , Case 632, 646

### NE556A,N

$T_A = 0^\circ$  to  $+70^\circ\text{C}$ , Case 646

### NE556D

$T_A = 0^\circ$  to  $+70^\circ\text{C}$ , Case 751

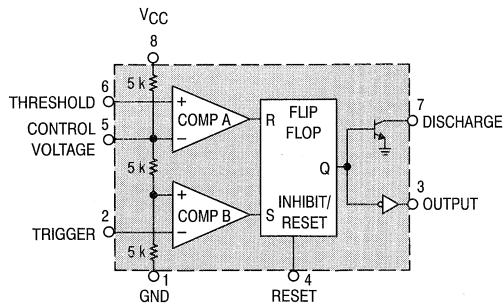

## Multipliers

### Linear Four-Quadrant Multipliers

Multipliers are designed for use where the output voltage is a linear product of two input voltages. Typical applications include: multiply, divide, square, root-mean-square, phase detector, frequency doubler, balanced modulator/demodulator, electronic gain control.

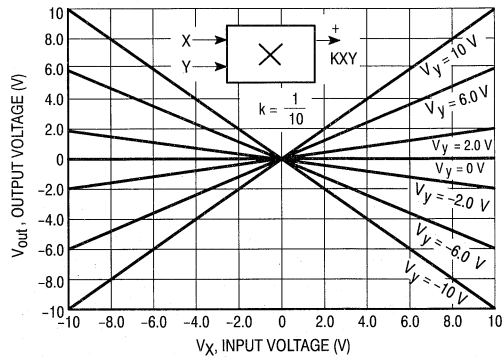

### MC1594L

$T_A = -55^\circ$  to  $+125^\circ\text{C}$ , Case 620

### MC1494L

$T_A = 0^\circ$  to  $+70^\circ\text{C}$ , Case 620

The MC1594/MC1494 is a variable transconductance multiplier with internal level-shift circuitry and voltage regulator. Scale factor, input offsets and output offset are completely adjustable with the use of four external potentiometers. Two complementary regulated voltages are provided to simplify offset adjustment and improve power supply rejection.

### MC1595L

$T_A = -55^\circ$  to  $+125^\circ\text{C}$ , Case 632

### MC1495L

$T_A = 0^\circ$  to  $+70^\circ\text{C}$ , Case 632

These devices are designed for uses where the output is a linear product of two input voltages. Maximum versatility is assured by allowing the user to select the level shift method. Typical applications include: multiply, divide<sup>(1)</sup>, square root<sup>(1)</sup>, mean square<sup>(1)</sup>, phase detector, frequency doubler, balanced modulator/demodulator, and electronic gain control.

<sup>(1)</sup> When used with an operational amplifier.

# Smoke Detectors (CMOS)

These smoke detector ICs require a minimum number of external components. When smoke is sensed, or a low battery voltage is detected, an alarm is sounded via an external

piezoelectric transducer. All devices are designed to comply with UL specifications.

**Table 64. Smoke Detectors (CMOS)**

Function	Recommended Power Source	Unique Feature	Low Battery Detector	Piezoelectric Horn Driver	Complies with UL217 and UL268	Device Number	Suffix/Package
Ionization-Type Smoke Detector	Battery	High Input Impedance FET Comparator	✓	✓	✓	MC14467-1	P1/626
	Line		—	—	✓	MC14578	P/648
Ionization-Type Smoke Detector with Interconnect	Battery		✓	✓	✓	MC14468	
	Line		—	✓	✓	MC14470	
Photoelectric-Type Smoke Detector with Interconnect	Battery	Photo Amplifier	✓	✓	✓	MC145010	P/648 DW/751G
	Line		(1)	✓	✓	MC145011	

(1) Low-supply detector.

# Other Linear Circuits Package Overview

4



CASE 620  
CERAMIC  
L SUFFIX



CASE 626  
PLASTIC  
P1 SUFFIX



CASE 632  
CERAMIC  
L SUFFIX



CASE 646  
PLASTIC  
P SUFFIX



CASE 648  
PLASTIC  
P SUFFIX



CASE 693  
CERAMIC  
U SUFFIX



CASE 707  
PLASTIC  
P SUFFIX

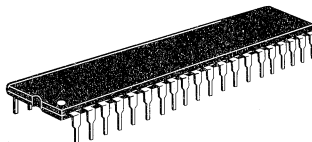

CASE 711  
PLASTIC  
P SUFFIX



CASE 738  
PLASTIC  
P SUFFIX



CASE 751B  
PLASTIC  
D SUFFIX



CASE 751D  
PLASTIC  
DW SUFFIX



CASE 751F  
PLASTIC  
DW SUFFIX



CASE 751G  
PLASTIC  
DW SUFFIX



CASE 777  
PLASTIC (PLCC)  
FN SUFFIX

# Surface Mount Technology

---

## In Brief . . .

Surface Mount Technology is now being utilized to offer answers to many problems that have been created in the use of Insertion Technology.

Limitations have been reached with insertion packages and PC board technology. Surface Mount Technology offers the opportunity to continue to advance state-of-the-art designs that cannot be accomplished with Insertion Technology.

Surface Mount packages allow more optimum device performance with the smaller Surface Mount configuration. Internal lead lengths, parasitic capacitance and inductance that placed limitations on chip performance, has been reduced.

The lower profile of Surface Mount packages allows more boards to be utilized in a given amount of space. They are stacked closer together and utilize less total volume than insertion populated PC boards.

Printed circuit costs are lowered with the reduction of the number of board layers required. The elimination or reduction of the number of plated-through-holes in the board, contribute significantly to lower PC board prices.

Surface Mount assembly does not require the preparation of components that are common on insertion technology lines. Surface Mount components are set directly to the assembly line, eliminating an intermediate step.

Automatic placement equipment is available that can place Surface Mount components at the rate of a few thousand per hour to hundreds of thousands of components per hour.

Surface Mount Technology is cost effective, allowing the manufacturer the opportunity to produce smaller units and offer increased functions with the same size product.

	<b>Page</b>
Linear and Interface .....	4.11-2
Bipolar .....	4.11-2
MOS Digital-Analog .....	4.11-6
Package Overview .....	4.11-8
Analog MPQ Table .....	4.11-8
Tape and Reel .....	4.11-9



# Linear and Interface

All the major bipolar analog families are now represented in surface mount packaging. Standard SOIC and PLCC packages are augmented by SOP-8 and DPAK for Linear regulators. In addition, tape and reel shipping to the updated

EIA-481A is now on line for the industry's largest array of operational amplifiers, regulators, interface, data conversion, consumer, telecom and automotive Linear ICs.

**Table 65. Bipolar**

Device	Function	Package
CA3146D	Transistor Array	SO-14
DAC-08CD, ED	High-Speed 8-Bit Multiplying D-to-A Converter	SO-16
LF351D	Single JFET Operational Amplifier	SO-8
LF353D	Dual JFET Operational Amplifiers	SO-8
LF411CD	Single/Dual JFET Operational Amplifier	SO-8
LF412CD	Dual JFET Operational Amplifiers	SO-8
LF441CD	Single JFET Low Power Operational Amplifier	SO-8
LF442CD	Dual JFET Low Power Operational Amplifiers	SO-8
LF444CD	Quad JFET Low Power Operational Amplifiers	SO-14
LM201AD	General Purpose Adjustable Operational Amplifier	SO-8
LM211D	High Performance Voltage Comparator	SO-8
LM224D	Quad Low Power Operational Amplifiers	SO-14
LM239D,AD	Quad Single Supply Comparators	SO-14
LM258D	Dual Low Power Operational Amplifiers	SO-8
LM285D-1.2	Micropower Voltage Reference Diode	SO-8
LM285D-2.5	Micropower Voltage Reference Diode	SO-8
LM293D	Dual Comparators	SO-8
LM301AD	General Purpose Adjustable Operational Amplifier	SO-8
LM311D	High Performance Voltage Comparator	SO-8
LM317LD	Positive Adjustable 100 mA Voltage Regulator	SOP-8
LM317MDT	Positive Adjustable 500 mA Voltage Regulator	DPAK
LM324D,AD	Quad Low Power Operational Amplifiers	SO-14
LM339D,AD	Quad Single Supply Comparators	SO-14
LM348D	Quad MC1741 Operational Amplifiers	SO-14
LM358D	Dual Low Power Operational Amplifiers	SO-8
LM385D-1.2	Micropower Voltage Reference Diode	SO-8
LM385D-2.5	Micropower Voltage Reference Diode	SO-8
LM393D	Dual Comparators	SO-8
LM833D	Dual Audio Amplifiers	SO-8
LM2901D	Quad Single Supply Comparators	SO-14
LM2902D	Quad Low Power Operational Amplifiers	SO-14
LM2903D	Dual Comparators	SO-8
LM2904D	Dual Low Power Operational Amplifiers	SO-8
LM2931AD-5.0,D-5.0	Low Dropout Voltage Regulator	SOP-8
LM2931CD	Adjustable Low Dropout Voltage Regulator	SOP-8
LM3900D	Quad Single Supply Operational Amplifiers	SO-14
MC1350D	IF Amplifier	SO-8
MC1357D	FM IC with Quadrature Detector	SO-14
MC1377DW	Color Television RGB to PAL/NTSC Encoder	SO-20L
MC1378FN	Video Overlay Synchronizer	PLCC-44
MC1382DW	Multimode Monitor TTL To Analog Video	SO-24L
MC1403D	Precision Low Voltage Reference	SO-8
MC1413D	Peripheral Driver Array	SO-16
MC1436D,CD	High Voltage Operational Amplifier	SO-8
MC1455D	Timing Circuit	SO-8
MC1458D,CD	Dual Operational Amplifiers	SO-8
MC14C88BD	Quad EIA-232-D/EIA-562 Drivers	SO-14
MC1488D	Quad EIA-232-D Drivers	SO-14

4

Table 65. Bipolar (continued)

Device	Function	Package
MC14C89ABD,BD	Quad EIA-232-D/EIA-562 Receivers	SO-14
MC1489D	Quad EIA-232-D Receivers	SO-14
MC1495D	Four-Quadrant Multiplier	SO-14
MC1496D	Balanced Modulator/Demodulator	SO-14
MC1723CD	Adjustable Positive or Negative Voltage Regulator	SO-14
MC1741CD	General Purpose Operational Amplifier	SO-8
MC1747CD	Dual MC1741 Operational Amplifiers	SO-14
MC1776CD	Programmable Operational Amplifier	SO-8
MC26LS31D	Quad EIA-422/23 Drivers	SO-16
MC26LS32D	Quad EIA-422 Receivers	SO-16
MC26S10D	Quad Bus Transceiver	SO-16
MC2831AD	FM Transmitter	SO-16
MC3303D	Quad Differential-Input Operational Amplifier	SO-14
MC3335DW	Basic Dual Conversion Receiver	SO-20L
MC3346D	General Purpose Transistor Array	SO-14
MC3356DW	FSK Receiver	SO-20L
MC3359DW	Low Power Narrowband FM IF Amplifier	SO-20L
MC3361AD	Low Voltage Narrowband FM IF Amplifier	SO-16
MC3362DW	Dual Conversion Receivers	SO-28L
MC3363DW	Dual Conversion Receivers	SO-28L
MC3367DW	Low Voltage VHF Receiver	SO-28L
MC3371D	Low Voltage FM Receiver with RSSI, LC Quadrature Detector	SO-16
MC3372D	Low Voltage FM Receiver with RSSI, Ceramic Quadrature Detector	SO-16
MC3391DW	Low Side Protected Switch	SOP-8+8L
MC3401D	Quad Operational Amplifiers	SO-14
MC3403D	Quad Differential-Input Operational Amplifier	SO-14
MC3418DW	CVSD	SO-16L
MC3423D	Overvoltage Sensing Circuit	SO-8
MC3448AD	Quad GPIB Transceivers	SO-16
MC3450D	Quad Line Receivers	SO-16
MC3452D	Quad Line Receivers	SO-16
MC3456D	Dual Timing Circuit	SO-14
MC3458D	Dual Low Power Operational Amplifiers	SO-8
MC3486D	Quad EIA-422/23 Receivers	SO-16
MC3487D	Quad EIA-422 Drivers	SO-16
MC4558CD	Dual High Frequency Operational Amplifiers	SO-8
MC4741CD	Quad MC1741 Operational Amplifiers	SO-14
MC78L05ACD	Positive Voltage Regulator, 5 V, 100 mA	SOP-8
MC78L08ACD	Positive Voltage Regulator, 8 V, 100 mA	SOP-8
MC78L12ACD	Positive Voltage Regulator, 12 V, 100 mA	SOP-8
MC78L15ACD	Positive Voltage Regulator, 15 V, 100 mA	SOP-8
MC78M05CDT	Positive Voltage Regulator, 5 V, 500 mA	DPAK
MC78M08CDT	Positive Voltage Regulator, 8 V, 500 mA	DPAK
MC78M12CDT	Positive Voltage Regulator, 12 V, 500 mA	DPAK
MC78M15CDT	Positive Voltage Regulator, 15 V, 500 mA	DPAK
MC79L05ACD	3-Terminal Negative Fixed Voltage Regulator, -5 V, 100 mA	SOP-8
MC79L12ACD	3-Terminal Negative Fixed Voltage Regulator, -12 V, 100 mA	SOP-8
MC79L15ACD	3-Terminal Negative Fixed Voltage Regulator, -15 V, 100 mA	SOP-8
MC79M05CDT	3-Terminal Negative Fixed Voltage Regulator, -5 V, 500 mA	DPAK
MC79M12CDT	3-Terminal Negative Fixed Voltage Regulator, -12 V, 500 mA	DPAK
MC79M15CDT	3-Terminal Negative Fixed Voltage Regulator, -15 V, 500 mA	DPAK
MC10319DW	8-Bit A/D Flash Converter	SO-24L
MC10321DW	7-Bit A/D Flash Converter	SO-20L
MC13022DW(1)	Medium Voltage AM Stereo C-QUAM® Decoder	SO-28L

(1) To be introduced.

**Table 65. Bipolar (continued)**

Device	Function	Package
MC13024DW	Low Voltage C–QUAM® Receiver	SO–24L
MC13055D	VHF LAN Receiver — FSK	SO–16
MC13060D	1 Watt Audio Amplifier	SOP–8
MC33023DW, FN	High Speed (1.0 MHz) Single–Ended PWM Controller	SO–16L, PLCC–20
MC33025DW, FN	High Speed (1.0 MHz) Double–Ended PWM Controller	SO–16L, PLCC–20
MC33033DW	Brushless DC Motor Controller	SO–20L
MC33035DW	Brushless DC Motor Controller	SO–24L
MC33039D	Closed Loop Brushless Motor Adaptor (5 V ± 5% Supply)	SO–8
MC33060AD	Precision Switchmode Pulse Width Modulator	SO–14
MC33064D–5	Undervoltage Sensing Circuit	SO–8
MC33065DW	Dual Current Mode PWM Controller	SO–16L
MC33065DW–H	Dual Current Mode PWM Controller (Off–Line)	SO–16L
MC33065DW–L	Dual Current Mode PWM Controller (DC–to–DC Converters)	SO–16L
MC33066DW	Resonant Mode (ZCS) Controller	SO–16L
MC33067DW	Resonant Mode (ZVS) Controller	SO–16L
MC33071D, AD	Single, High Speed Single Supply Operational Amplifiers	SO–8
MC33072D, AD	Dual, High Speed Single Supply Operational Amplifiers	SO–8
MC33074D, AD	Quad, High Speed Single Supply Operational Amplifiers	SO–14
MC33076D	Dual High Output Current Operational Amplifiers	SO–8
MC33077D	Dual, Low Noise High Frequency Operational Amplifiers	SO–8
MC33078D	Dual Audio, Low Noise Operational Amplifiers	SO–8
MC33079D	Low Power, Single Supply Operational Amplifier	SO–14
MC33091D	High Side T MOS Driver	SO–8
MC33102D	Sleep–Mode™ 2–State, µProcessor Operational Amplifier	SO–8
MC33110D	Low Voltage Compander	SO–14
MC33120FN	SLIC II	PLCC–28
MC33121FN	Low Voltage Subscriber Loop Interface Circuit	PLCC–28
MC33129D	High Performance Current Mode Controller	SO–14
MC33151D	Dual Inverting MOSFET Drivers	SO–8
MC33152D	Dual Noninverting MOSFET Drivers	SO–8
MC33161D	Universal Voltage Monitor	SO–8
MC33164D–3	Micropower Undervoltage Sensing Circuit (3 V ± 5% Supply)	SO–8
MC33164D–5	Micropower Undervoltage Sensing Circuit (5 V ± 10% Supply)	SO–8
MC33171D	Single, Low Power, Single Supply Operational Amplifier	SO–8
MC33172D	Dual, Low Power, Single Supply Operational Amplifiers	SO–8
MC33174D	Quad, Low Power, Single Supply Operational Amplifiers	SO–14
MC33178D	Dual Precision Operational Amplifiers	SO–8
MC33179D	Quad Precision Operational Amplifiers	SO–14
MC33218DW	Voice–Switched Speakerphone with µProcessor Interface	SO–24L
MC33261D	Power Factor Controller	SO–8
MC33272D	Dual Precision Bipolar Operational Amplifiers	SO–8
MC33274D	Quad Precision Bipolar Operational Amplifiers	SO–14
MC33282D	Dual Precision Low Input JFET Operational Amplifiers (Trim–in–the–Package)	SO–8
MC33284D	Quad Precision JFET Operational Amplifiers (Trim–in–the–Package)	SO–14
MC34001D, BD	Single JFET Input Operational Amplifier	SO–8
MC34002D, BD	Dual JFET Input Operational Amplifiers	SO–8
MC34010FN	Electronic Telephone Circuit	PLCC–44
MC34012–1D	Telephone Tone Ringer	SO–8
MC34012–2D	Telephone Tone Ringer	SO–8
MC34012–3D	Telephone Tone Ringer	SO–8
MC34014DW	Telephone Speech Network with Dialer Interface	SO–20L
MC34017–1D	Telephone Tone Dialer	SO–8
MC34017–2D	Telephone Tone Dialer	SO–8
MC34017–3D	Telephone Tone Dialer	SO–8
MC34018DW	Voice Switched Speakerphone Circuit	SO–28L
MC34023DW, FN	High Speed (1.0 MHz) Single–Ended PWM Controller	SO–16L, PLCC–20

4

**Table 65. Bipolar (continued)**

Device	Function	Package
MC34025DW,FN	High Speed (1.0 MHz) Double-Ended PWM Controller	SO-16L, PLCC-20
MC34050D	EIA-422/23 Transceivers	SO-16
MC34051D	EIA-422/23 Transceivers	SO-16
MC34060AD	Switchmode Pulse Width Modulation Control Circuit	SO-14
MC34063AD	Precision DC-to-DC Converter Control Circuit	SO-8
MC34064D-5	Undervoltage Sensing Circuit (5 V ± 5% Supply)	SO-8
MC34065DW	Dual Current Mode PWM Controller	SO-16L
MC34065DW-H	Dual Current Mode PWM Controller (Off-Line)	SO-16L
MC34065DW-L	Dual Current Mode PWM Controller (DC-to-DC Converter)	SO-16L
MC34066DW	Resonant Mode (ZCS) Controller	SO-16L
MC34067DW	Resonant Mode (ZVS) Controller	SO-16L
MC34071D,AD	Single, High Speed, Single Supply Operational Amplifier	SO-8
MC34072D,AD	Dual, High Speed, Single Supply Operational Amplifiers	SO-8
MC34074D,AD	Quad, High Performance, Single Supply Operational Amplifiers	SO-14
MC34080D	High Speed Decompensated ( $A_{VCL} \geq 2$ ) JFET Input Operational Amplifier	SO-8
MC34081D	High Speed JFET Input Operational Amplifier	SO-8
MC34084DW,ADW	Quad High Speed, JFET Operational Amplifier	SO-16L
MC34085DW,ADW	Quad High Speed, JFET Operational Amplifier	SO-16L
MC34114DW	Speech Network II	SO-18L
MC34115DW	CVSD	SO-16L
MC34118DW	Speakerphone II	SO-28L
MC34119D	Telephone Speaker Amplifier	SO-8
MC34129D	Power Supply Controller	SO-14
MC34151D	Dual Inverting MOSFET Drivers	SO-8
MC34152D	Dual Noninverting MOSFET Drivers	SO-8
MC34161D	Universal Voltage Monitor	SO-8
MC34164D-3	Micropower Undervoltage Sensing Circuit (3 V ± 5% Supply)	SO-8
MC34164D-5	Micropower Undervoltage Sensing Circuit (5 V ± 10% Supply)	SO-8
MC34181D	Single, Low Power, High Speed JFET Operational Amplifier	SO-8
MC34182D	Dual, Low Power, High Speed JFET Operational Amplifiers	SO-8
MC34184D	Quad, Low Power, High Speed JFET Operational Amplifiers	SO-14
MC34217D	Adjustable Toner Ringer	SO-8
MC34261D	Power Factor Controller	SO-8
MC44301DW	High Performance Video IF	SO-28L
MC75172BDW	Quad EIA-485 Line Drivers w/3-State Outputs	SO-20L
MC75174BDW	Quad EIA-485 Line Drivers w/3-State Outputs	SO-20L
NE556D	Dual Timing Circuit	SO-14
TL064CD	Quad JFET Low Power Operational Amplifiers	SO-14
TL071CD,ACD	Single, Low Noise JFET Input Operational Amplifier	SO-8
TL072CD,ACD	Dual, Low Noise JFET Input Operational Amplifiers	SO-8
TL081CD,ACD	Single, JFET Input Operational Amplifier	SO-8
TL082CD,ACD	Dual, JFET Input Operational Amplifiers	SO-8
TL431ACD,AID,CD,ID	Programmable Precision Reference	SOP-8
UAA1041D	Automotive Direction Indicator	SO-8
UC2842AD, BD, BD1	Off-Line Current Mode PWM Controller	SO-14, SO-8
UC2843AD, BD, BD1	Current Mode PWM Controller	SO-14, SO-8
UC2844D, BD, BD1	Off-Line Current Mode PWM Controller (DC ≤ 50%)	SO-14, SO-8
UC2845D, BD, BD1	Current Mode PWM Controller (DC ≤ 50%)	SO-14, SO-8
UC3842AD, BD, BD1	Off-Line Current Mode PWM Controller	SO-14, SO-8
UC3843AD, BD, BD1	Current Mode PWM Controller	SO-14, SO-8
UC3844D, BD, BD1	Off-Line Current Mode PWM Controller (DC ≤ 50%)	SO-14, SO-8
UC3845D, BD, BD1	Current Mode PWM Controller (DC ≤ 50%)	SO-14, SO-8

4

**Table 66. MOS Digital–Analog**

Device	Function	Package
<b>A/D and D/A Converters</b>		
MC14433DW	3–1/2 Digit A/D Converter	SO–24L
MC14442FN	11–Channel 8–Bit A/D Converter with Parallel Interface	PLCC–28
MC14443DW	6–Channel A/D Converter Subsystem	SO–16L
MC14447DW	6–Channel A/D Converter Subsystem	SO–16L
MC44250FN	Triple 8–Bit Video A/D Converter	PLCC–44
MC144110DW	Hex D/A Converter with Serial Interface	SO–20L
MC144111DW	Quad D/A Converter with Serial Interface	SO–16L
MC145040FN1(2)	11–Channel, 8–Bit A/D Converter with Serial Interface	PLCC–20
MC145040FN2(2)	11–Channel, 8–Bit A/D Converter with Serial Interface	PLCC–20
MC145041FN1(2)	11–Channel, 8–Bit A/D Converter with Serial Interface	PLCC–20
MC145041FN2(2)	11–Channel, 8–Bit A/D Converter with Serial Interface	PLCC–20
MC145050DW	11–Channel, 10–Bit A/D Converter with Serial Interface	SO–20L
MC145051DW	11–Channel, 10–Bit A/D Converter with Serial Interface	SO–20L
MC145053D	11–Channel, 10–Bit A/D Converter with Serial Interface	SO–14
<b>Display Drivers</b>		
MC14489DW	Multi–Character LED Display/Lamp Driver	SO–20L
MC14495DW1(2)	Hex–to–7 Segment Latch/Decoder ROM/Driver	SO–16L
MC14499DW	7–Segment LED Display Decoder/Driver with Serial Interface	SO–20L
MC145000FN	48–Segment Multiplexed LCD Driver (Master)	PLCC–28
MC145001FN	44–Segment Multiplexed LCD Driver (Slave)	PLCC–28
MC145453FN	33–Segment LCD Driver with Serial Interface	PLCC–44
<b>Operational Amplifiers/Comparators</b>		
MC14573D	Quad Programmable Operational Amplifier	SO–16
MC14574D	Quad Programmable Comparator	SO–16
MC14575D	Dual Programmable Operational Amplifier and Dual Comparator	SO–16
MC14576BF	Dual Video Amplifier	SO–8 (EIAJ)
MC14577BF	Dual Video Amplifier	SO–8 (EIAJ)
MC14578D	Micro–Power Comparator Plus Voltage Follower	SO–16
<b>Phase–Locked–Loop Frequency Synthesizers</b>		
MC145106FN	PLL Frequency Synthesizer	PLCC–20
MC145145DW1	4–Bit Data Bus Input PLL Frequency Synthesizer	SO–20L
MC145146DW1	4–Bit Data Bus Input PLL Frequency Synthesizer	SO–20L
MC145149DW	Serial Input Dual PLL Frequency Synthesizer	SO–20L
MC145151DW2	Parallel Input PLL Frequency Synthesizer	SO–28L
MC145151FN2	Parallel Input PLL Frequency Synthesizer	PLCC–28
MC145152DW2	Parallel Input PLL Frequency Synthesizer	SO–28L
MC145152FN2	Parallel Input PLL Frequency Synthesizer	PLCC–28
MC145155FN2	Serial Input PLL Frequency Synthesizer	PLCC–20
MC145155DW2	Serial Input PLL Frequency Synthesizer	SO–20L
MC145156FN2	Serial Input PLL Frequency Synthesizer	PLCC–20
MC145156DW2	Serial Input PLL Frequency Synthesizer	SO–20L
MC145157FN2	Serial Input PLL Frequency Synthesizer	PLCC–20
MC145157DW2	Serial Input PLL Frequency Synthesizer	SO–16L
MC145158FN2	Serial Input PLL Frequency Synthesizer	PLCC–20
MC145158DW2	Serial Input PLL Frequency Synthesizer	SO–16L
MC145159DW1	Serial Input PLL Frequency Synthesizer with Analog Phase Detector	SO–20L
MC145159FN(3)	Serial Input PLL Frequency Synthesizer with Analog Phase Detector	PLCC–20
MC145160DW	Dual PLL for Cordless Telephones	SO–20L
MC145161DW	Dual PLL for Cordless Telephones	SO–16L
MC145166DW	Dual PLL for Cordless Telephones	SO–16L
MC145167DW	Dual PLL for Cordless Telephones	SO–16L
MC145168DW	Dual PLL for Cordless Telephones	SO–16L
MC145170D	Serial Interface PLL Frequency Synthesizer	SO–16

(2) The digit 1 or 2 after the package designator is not a part of the package definition, but describes electrical capability of the device.

(3) Electrical variations may require a numerical suffix after the package suffix. Contact your Motorola representative for details.

**4**

**Table 66. MOS Digital—Analog (continued)**

Device	Function	Package
<b>Remote Control Functions</b>		
MC14469FN	Addressable Asynchronous Receiver/Transmitter	PLCC-44
MC14497	PCM Remote Control Transmitter	(4)
MC145026D	Remote Control Encoder	SO-16
MC145027DW	Remote Control Decoder	SO-16L
MC145028DW	Remote Control Decoder	SO-16L
MC145030DW	Remote Control Encoder/Decoder	SO-20
MC145033DW	Remote Control Encoder/Decoder	SO-28L
MC145034DW	Remote Control Encoder	SO-28L
MC145035DW	Remote Control Decoder	SO-28L
<b>Smoke Detectors</b>		
MC14467	Low-Cost Smoke Detector	(4)
MC14468	Interconnectable Smoke Detector	(4)
MC145010DW	Photoelectric Smoke Detector with I/O	SO-16L
MC145011DW	Photoelectric Smoke Detector with I/O	SO-16L
<b>Telecommunications Devices</b>		
MC14410DW	2-of-8 Tone Encoder	SO-16L
MC14411DW	Bit Rate Generator	SO-24L
MC142100DW	Crosspoint Switch with Control Memory (4 × 4 × 1)	SO-16L
MC142103	Transcoder HDB31 AMI to NRZ	(4)
MC143403D	Quad Line Driver (Op Amp)	SO-14
MC145403DW	EIA-232/V.28 CMOS Driver/Receiver	SO-20L
MC145404DW	EIA-232/V.28 CMOS Driver/Receiver	SO-20L
MC145405DW	EIA-232/V.28 CMOS Driver/Receiver	SO-20L
MC145406DW	EIA-232/V.28 CMOS Driver/Receiver	SO-16L
MC145407DW	EIA-232/V.28 CMOS Driver/Receiver, 5.0 V Only	SO-20L
MC145408DW	EIA-232/V.28 CMOS Driver/Receiver	SO-20L
MC145412	Pulse/Tone Repertory Dialer (Nine 18-Digit Memory)	(4)
MC145416DW	Pulse/Tone Repertory Dialer (13 18-Digit Memory)	SO-20L
MC145421DW	UDLT II Master	SO-24L
MC145422DW	UDLT Master	SO-24L
MC145425DW	UDLT II Slave	SO-24L
MC145426DW	UDLT Slave	SO-24L
MC145428DW	Data Set Interface Circuit	SO-20L
MC145436DW	DTMF Decoder	SO-16L
MC145439	Transcoder B8ZS, B6ZS, HDB3 to NRZ	(4)
MC145442DW	300-Baud CCITT V.21 Single-Chip Modem	SO-20L
MC145443DW	300-Baud Bell 103 Single-Chip Modem	SO-20L
MC145447DW	Calling Line I.D. Receiver with Ring Detector	SO-16L
MC145472FE	ISDN U-Interface Transceiver	CQFP-68L
MC145472FU	ISDN U-Interface Transceiver	PQFP-68L
MC145475DW	ISDN S/T Transceiver	SO-28L
MC145480DW	+5.0 V PCM Codec/Filter	SO-20L
MC145488	Dual Data Link Controller	(4)
MC145502	PCM Codec/Filter	(4)
MC145503DW	PCM Codec/Filter	SO-16L
MC145505DW	PCM Codec/Filter	SO-16L
MC145532DW	ADPCM Transcoder	SO-16L
MC145540DW	ADPCM Codec	SO-28L
MC145554DW	PCM Codec/Filter (TP3054 Compatible)	SO-16L
MC145557DW	PCM Codec/Filter (TP3057 Compatible)	SO-16L
MC145564DW	PCM Codec/Filter (TP3064 Compatible)	SO-20L
MC145567DW	PCM Codec/Filter (TP3067 Compatible)	SO-20L
MC145705DW	EIA-232/V.28 CMOS Driver/Receiver, 5.0 V Only	SO-20L
MC145706DW	EIA-232/V.28 CMOS Driver/Receiver, 5.0 V Only	SO-20L
MC145707DW	EIA-232/V.28 CMOS Driver/Receiver, 5.0 V Only	SO-20L

(4) Introduction of this device in surface mount packages is dependent on market demand.

# Surface Mount Technology Package Overview

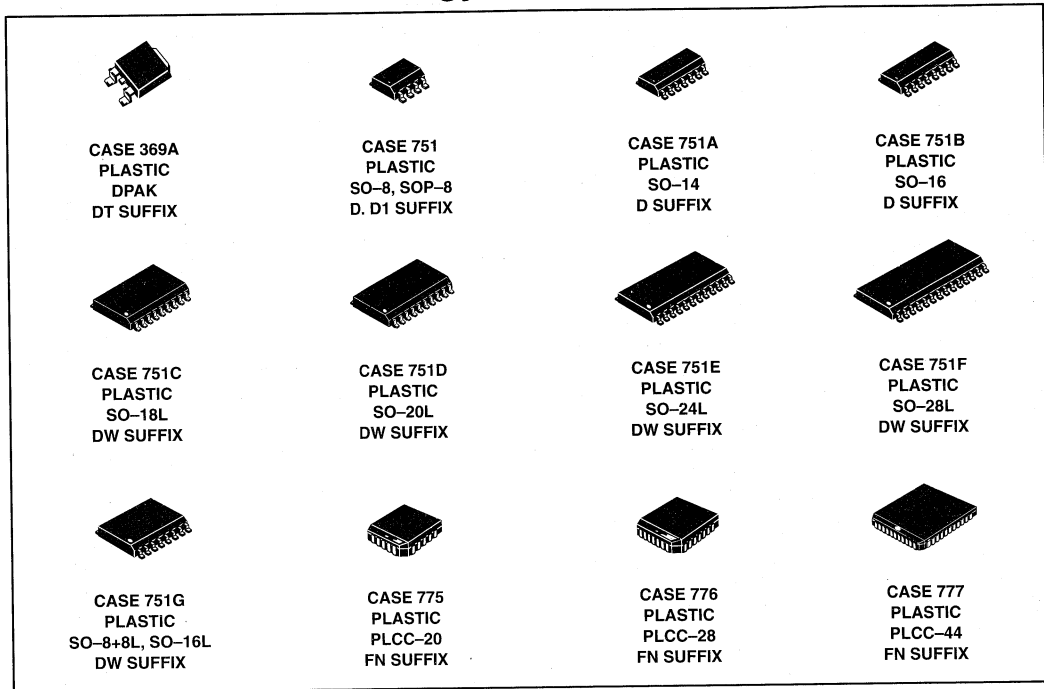

4

## Analog MPQ Table

Table 67. Tape/Reel and Ammo Pack

Package Type	Package Code	MPQ
<b>PLCC</b>		
Case 775	0802	1000/reel
Case 776	0804	500/reel
Case 777	0801	500/reel
Case 778	0805	450/reel
Case 779	0803	250/reel
Case 780	0806	250/reel
<b>SOIC</b>		
Case 751	0095	2500/reel
Case 751A	0096	2500/reel
Case 751B	0097	2500/reel
Case 751G	2003	1000/reel
Case 751C	2004	1000/reel
Case 751D	2005	1000/reel
Case 751E	2008	1000/reel
Case 751F	2009	1000/reel
<b>TO-92</b>		
Case 29	0031	2000/reel
Case 29	0031	2000/Ammo Pack

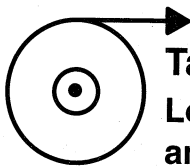

## Tape and Reel Logic and Analog Technologies, and MOS Integrated Circuits

Motorola has now added the convenience of Tape and Reel packaging for our growing family of standard Integrated Circuit products. Three reel sizes are available, for all but the largest types, to support the requirements of both first and second

generation pick-and-place equipment. The packaging fully conforms to the latest EIA-481A specification. The antistatic embossed tape provides a secure cavity, sealed with a peel-back cover tape.

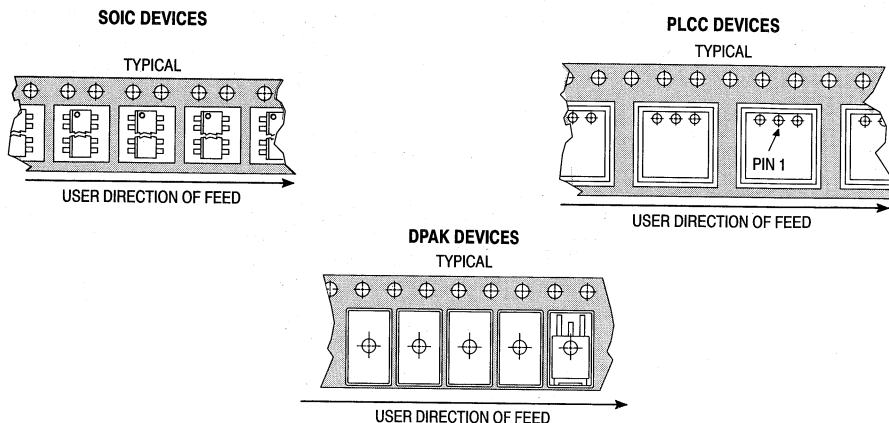

Figure 5. Mechanical Polarization

Package	Tape Width (mm)	Device(1) per Reel	Reel Size (inch)	Device Suffix
SO-8, SOP-8	12	2,500	13	R2
SO-14	16	2,500	13	R2
SO-16	16	2,500	13	R2
SO-16L, SO-8+8L WIDE	16	1,000	13	R2
SO-20L WIDE	24	1,000	13	R2
SO-24L WIDE	24	1,000	13	R2
SO-28L WIDE	24	1,000	13	R2
SO-28L WIDE	32	1,000	13	R3
PLCC-20	16	1,000	13	R2
PLCC-28	24	500	13	R2
PLCC-44	32	500	13	R2
PLCC-52	32	500	13	R2
PLCC-68	44	250	13	R2
PLCC-84	44	250	13	R2
TO-226AA (TO-92)(2)	18	2,000	13	RA, RB, RE, RM, or RP (Ammo Pack) only
DPAK	16	2,500	13	RK

(1) Minimum order quantity is 1 reel. Distributors/OEM customers may break lots or reels at their option, however broken reels may not be returned.

(2) Integrated circuits in TO-226AA packages are available in Styles A, B and E only, with optional "Ammo Pack" (Suffix RM or RP).

For ordering information please contact your local Motorola Semiconductor Sales Office.



## Tape and Reel (continued)

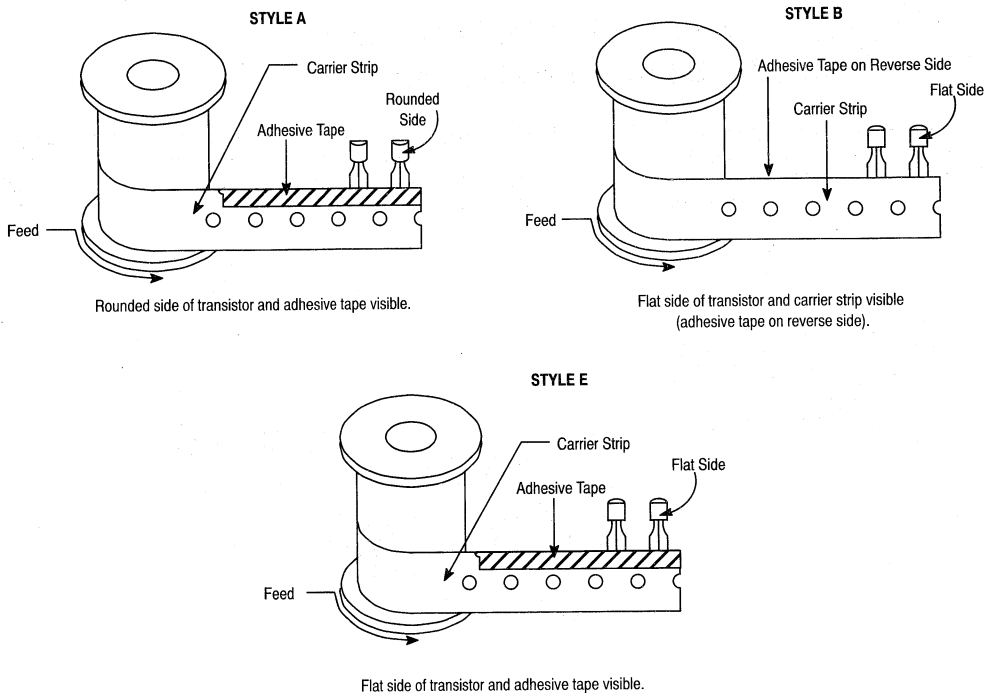

4

Figure 6. TO-92 Reel Styles

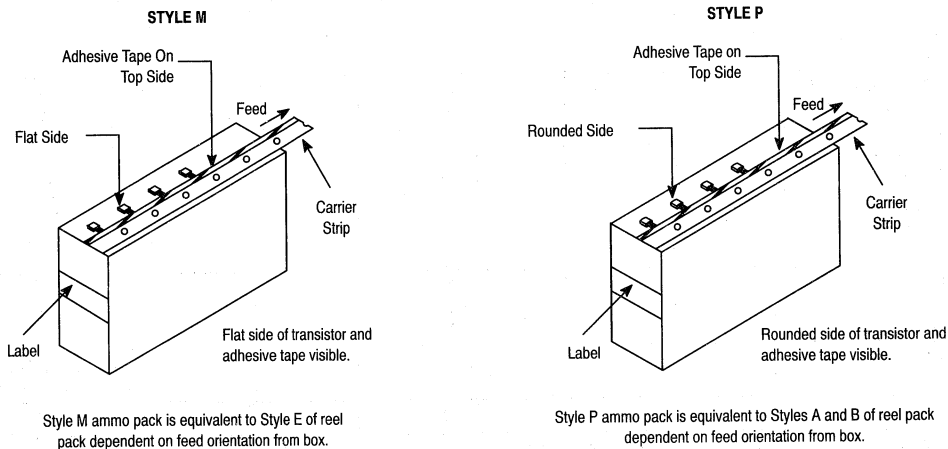

Figure 7. TO-92 Ammo Pack Styles

# Discrete Products

---

## In Brief . . .

Many leading semiconductor manufacturers have either de-emphasized or eliminated discrete components from their product portfolio. At Motorola, exceptional long-term growth and outstanding customer acceptance of our portfolio are the most significant effects of Motorola's superiority in providing bipolar and MOS transistors, diodes, thyristors, zeners, opto, RF, rectifier, and sensor devices.

Consistent, ongoing improvements in product development and packaging processing continue to ensure Motorola's position as the most broad-based discrete supplier in the world. The increased use of automatic placement equipment has driven the trend towards surface mount packaging.

Motorola continues to expand upon a broad offering of discrete surface mount packages which continue to advance state-of-the-art designs that cannot be accomplished with insertion technology. Surface mount technology is cost effective, allowing users the opportunity to utilize smaller units and increased functions with less board space. In many electronic applications, complex integrated solutions with a multitude of functions can replace several active and passive components.

SMARTDISCRETES, RF hybrid amplifiers and modules, pressure and temperature sensors, optoelectronics and hybrid power modules are a few of the exciting new products which provide more reliable, intelligent discrete devices. Key initiatives to raise products and services to a Six Sigma standard (99.9997% defect-free), reduce total cycle time in all activities, and provide leadership in the areas of product and manufacturing ensure that Motorola will continue to be the manufacturer of choice for all your discrete semiconductor requirements.

	Page
Small Signal Transistors, FETs and Diodes . . . . .	5.1-1
TVS/Zeners	
Transient Voltage Suppressors	
Zener Regulator and Reference Diodes . . . . .	5.2-1
Hybrid Power Module Operation . . . . .	5.3-1
TMOS Power MOSFETs Products . . . . .	5.4-1
Bipolar Power Transistors . . . . .	5.5-1
Rectifiers . . . . .	5.6-1
Thyristors and Triggers . . . . .	5.7-1
Optoelectronic Devices . . . . .	5.8-1
Sensors . . . . .	5.9-1
RF Products . . . . .	5.10-1
Surface Mount Information . . . . .	5.11-1
Tape and Reel Specifications and Packaging Specifications . . . . .	5.12-1
Leadform Options . . . . .	5.13-1

## MOTOROLA DEVICE CLASSIFICATIONS

In an effort to provide up-to-date information to the customer regarding the status of any given device, Motorola has classified all devices into three categories: Preferred devices, Current products and Not Recommended for New Design products.

A Preferred type is a device which is recommended as a first choice for future use. These devices are "preferred" by virtue of their performance, price, functionality, or combination of attributes which offer the overall "best" value to the customer. This category contains both advanced and mature devices which will remain available for the foreseeable future.

"Preferred devices" are listed in bold, italic within each Product Group's device tables.

Device types identified as "current" may not be a first choice for **new** designs, but will continue to be available because of the popularity and/or standardization or volume usage in current production designs. These products can be acceptable for new designs but the preferred types are considered better alternatives for long term usage.

Any device that has not been identified as a "preferred device" is a "current" device.

Products designated as "Not Recommended for New Design" may become obsolete as dictated by poor market acceptance, or a technology or package that is reaching the end of its life cycle. Devices in this category have an uncertain future and do not represent a good selection for new device designs or long term usage.

The Discrete section of the *Master Selection Guide* does not contain any "Not Recommended for New Design" devices.

5

Note: The Communications, Power and Signal Technologies Group's section in *Master Selection Guide* has identified those devices that are a preferred type. No other product family's devices have been identified as such in this edition of the *Master Selection Guide*.

# Small Signal Transistors, FETs and Diodes

---

## In Brief . . .

This section highlights semiconductors that are the most popular and have a history of high usage for the most applications.

It covers a wide range of Small Signal plastic and metal-can semiconductors.

A large selection of encapsulated plastic transistors, FETs and diodes are available for surface mount and insertion assembly technology. Plastic packages include TO-92 (TO-226AA), 1 Watt TO-92 (TO-226AE), SOT-23, SC-59, SC-70/SOT-323 and SOT-223. Plastic multiples are available in 14-pin and 16-pin dual in-line packages for insertion applications: SO-8, SO-14, and SO-16 for surface mount applications.

Metal-can packages are available for applications requiring higher power dissipation or having hermetic requirements in TO-18 (TO-206AA) and TO-39 (TO-205AD).

	Page
Bipolar Transistors . . . . .	5.1-2
Plastic-Encapsulated Transistors . . . . .	5.1-2
Plastic-Encapsulated Multiple Transistors . . . . .	5.1-8
Plastic-Encapsulated Surface Mount Transistors . . . . .	5.1-10
Metal-Can Transistors . . . . .	5.1-17
Field-Effect Transistors . . . . .	5.1-20
JFETs . . . . .	5.1-20
MOSFETs . . . . .	5.1-22
Surface Mount FETs . . . . .	5.1-23
Tuning and Switching Diodes . . . . .	5.1-25
Tuning Diodes — Abrupt Junction . . . . .	5.1-25
Tuning Diodes — Hyper-Abrupt Junction . . . . .	5.1-29
Hot-Carrier (Schottky) Diodes . . . . .	5.1-33
Switching Diodes . . . . .	5.1-34
Multiple Switching Diodes . . . . .	5.1-37

# Bipolar Transistors

## Plastic-Encapsulated Transistors

Motorola's Small Signal TO-226 plastic transistors encompass hundreds of devices with a wide variety of characteristics for general-purpose, amplifier and switching applications. The popular high-volume package combines proven reliability, performance, economy and convenience to provide the perfect solution for industrial and consumer design problems. All devices are laser marked for ease of identification and shipped in antistatic containers, as part of Motorola's ongoing practice of maintaining the highest standards of quality and reliability.

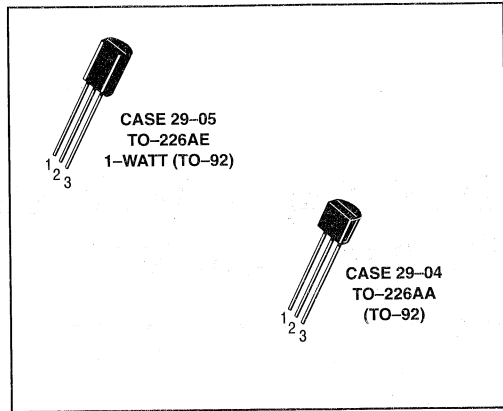

**Table 1. Plastic-Encapsulated General-Purpose Transistors**

These general-purpose transistors are designed for small-signal amplification from dc to low ratio frequencies. They are also useful as oscillators and general-purpose switches. Complementary devices shown where available (Tables 1-4).

NPN	PNP	$V_{(BR)CEO}$ Volts Min	$f_T @ I_C$		$I_C$ mA Max	$h_{FE} @ I_C$			NF dB Max	Style
			MHz Min	mA		Min	Max	mA		

**Case 29-04 — TO-226AA (TO-92)**

<b><i>MPS8099</i></b>	<b><i>MPS8599</i></b>	80	150	10	500	100	300	1.0	—	1
<b><i>MPSA06</i></b>	<b><i>MPSA56</i></b>	80	100	10	500	100	—	100	—	1
2N4410	—	80	60	10	250	60	400	10	—	1
BC546	BC556	65	150	10	100	120	450	2.0	10	17
BC546A	BC556A	65	150	10	100	120	220	2.0	10	17
BC546B	BC556B	65	150	10	100	180	450	2.0	10	17
MPSA05	MPSA55	60	100	10	500	100	—	100	—	1
—	<b><i>MPS2907A</i></b>	60	200	50	600	100	300	150	—	1
BC182	BC212	50	200 <sup>(1)</sup>	10	100	120	500	2.0	10	14
BC237B	BC307B	45	150	10	100	200	460	2.0	10	17
BC337	BC327	45	210 <sup>(1)</sup>	10	800	100	630	100	—	17
BC547	BC557	45	150	10	100	120	800	2.0	10	17
BC547A	BC557A	45	150	10	100	120	220	2.0	10	17
BC547B	BC557B	45	150	10	100	180	450	2.0	10	17
BC547C	BC557C	45	150	10	100	380	800	2.0	10	17
MPSA20	MPSA70	40	125	5.0	100	40	400	5.0	—	1
<b><i>MPS2222A</i></b>	—	40	300	20	600	100	300	150	—	1
<b><i>2N4401</i></b>	<b><i>2N4403</i></b>	40	200	20	600	100	300	150	—	1
2N4400	2N4402	40	150	20	600	50	150	150	—	1
<b><i>MPS6602</i></b>	<b><i>MPS6652</i></b>	40	100	50	1000	50	—	500	—	1
2N3903	2N3905	40	200	10	200	50	150	10	6.0	1
<b><i>2N3904</i></b>	<b><i>2N3906</i></b>	40	250	10	200	100	300	10	5.0	1
BC548	—	30	300 <sup>(1)</sup>	10	100	110	800	2.0	10	17
BC548A	—	30	300 <sup>(1)</sup>	10	100	120	220	2.0	10	17
BC548B	BC558B	30	300 <sup>(1)</sup>	10	100	200	450	2.0	10	17
BC548C	—	30	300	10	100	420	800	2.0	10	17
2N4123	2N4125	30	200	10	200	50	150	2.0	6.0	1
2N4124	2N4126	25	250	10	200	120	360	2.0	4.0	1
BC338	BC328	25	210 <sup>(1)</sup>	10	800	100	630	100	—	17

<sup>(1)</sup> Typical

Devices listed in bold, italic are Motorola preferred devices.

5

## Plastic-Encapsulated Transistors (continued)

**Table 1. Plastic-Encapsulated General-Purpose Transistors (continued)**

NPN	PNP	V <sub>(BR)</sub> CEO Volts Min	f <sub>T</sub> @ I <sub>C</sub>		I <sub>C</sub> A Max	h <sub>FE</sub> @ I <sub>C</sub>			V <sub>CE(sat)</sub> @ I <sub>C</sub> @ I <sub>B</sub>			Style
			MHz Min	mA		Min	Max	mA	Volts Max	mA	mA	
<b>Case 29-05 — TO-226AE (1-WATT TO-92)</b>												
BDB01D	BDB02D	100	50	200	0.5	40	400	100	0.7	1000	100	1
BDC01D	BDC02D	100	50	200	0.5	40	400	100	0.7	1000	100	14
BDB01C	BDB02C	80	50	200	0.5	40	400	100	0.7	1000	100	1
MPS6717		80	50	200	0.5	80	—	50	0.5	250	10	1
<b>MPSW06</b>	<b>MPSW56</b>	80	50	200	0.5	80	—	50	0.4	250	10	1

**Table 2. Plastic-Encapsulated Low-Noise and Good h<sub>FE</sub> Linearity**

These devices are designed to use on applications where good h<sub>FE</sub> linearity and low-noise characteristics are required: Instrumentation, hi-fi preamplifier.

NPN	PNP	V <sub>(BR)</sub> CEO Volts	h <sub>FE</sub> @ I <sub>C</sub>			V <sub>T</sub> (4) mV Typ	NF(5) dB Max	f <sub>T</sub> MHz Typ	Style
			Min	Max	mA				

**Case 29-04 — TO-226AA (TO-92)**

—	<b>2N5087</b>	50	250	800	0.1	—	2.0	40(2)	1
—	2N5086	50	150	500	0.1	—	3.0	40(2)	1
MPS6428	—	50	250	650	0.1	7.0(7)	3.5(8)	100(2)	1
BC239	—	45	120	800	2.0	9.5	2.0(1)	280	17
BC550B	BC560B	45	180	450	2.0	—	2.5	250	17
BC550C	BC560C	45	380	800	2.0	—	2.5	250	17
<b>MPSA18</b>	—	45	500	—	1.0	6.5(1)	—	160	1
MPS3904	MPS3906	40	100	300	10	—	5.0	200(2)	1
—	MPS4250	40	250	—	10	—	2.0	—	1
BC549B	BC559B	30	200	450	2.0	—	2.5	250	17
BC549C	BC559C	30	380	800	2.0	—	2.5	250	17
2N5088	—	30	350	—	1.0	—	3.0	50	1
2N5089(6)	—	25	450	—	1.0	—	2.0	50	1
<b>MPS6521</b>	MPS6523	25	300	600	2.0	—	3.0	—	1

(1) Typical

(2) Min

(4) V<sub>T</sub>: Total Input Noise Voltage (see BC413/BC414 and BC415/BC416 Data Sheets) at R<sub>S</sub> = 2.0 kΩ, I<sub>C</sub> = 200 μA, V<sub>CE</sub> = 5.0 Volts.

(5) NF: Noise Figure at R<sub>S</sub> = 2.0 kΩ, I<sub>C</sub> = 200 μA, V<sub>CE</sub> = 5.0 Volts. f = 30 Hz to 15 kHz.

(7) R<sub>S</sub> = 10 kΩ, BW = 1.0 Hz, f = 100 MHz

(8) R<sub>S</sub> = 500 Ω, BW = 1.0 Hz, f = 10 MHz

5

Devices listed in bold, italic are Motorola preferred devices.

## Plastic-Encapsulated Transistors (continued)

**Table 3. Plastic-Encapsulated Darlington Transistors**

Darlington amplifiers are cascade transistors used in applications requiring very high-gain and input impedance. These devices have monolithic construction.

NPN	PNP	V <sub>(BR)CEO</sub> Volts	I <sub>C</sub> Max	hFE @ I <sub>C</sub>			V <sub>CE(sat)</sub> @ I <sub>C</sub> & I <sub>B</sub>			f <sub>T</sub> @ I <sub>C</sub>		Style
				Min	Max	mA	Volts Max	mA	mA	Min	mA	

**Case 29-05 — TO-226AE (1-WATT TO-92)**

<b>MPSW45A</b>	—	50	1000	25K	150K	200	1.5	1000	2.0	100	200	1
—	<b>MPSW64</b>	30	1000	20K	—	100	1.5	100	0.1	125	10	1

**Case 29-04 — TO-226AA (TO-92)**

<b>MPSA29</b>	—	100	500	10K	—	100	1.5	100	0.1	125	10	1
BC373	—	80	1000	10K	160K	100	1.1	250	0.25	100	100	1
MPSA27	MPSA77	60	500	10K	—	100	1.5	100	0.1	—	—	1
BC618	—	55	1000	10K	50K	200	1.1	200	0.2	150	500	17
—	MPSA75	40	500	10K	—	100	1.5	100	0.1	—	—	1
2N6427	—	40	500	20K	200K	100	1.5	500	0.5	—	—	1
2N6426	—	40	500	30K	300K	100	1.5	500	0.5	125	10	1
<b>MPSA14</b>	<b>MPSA64</b>	30	500	20K	—	100	1.5	100	0.1	125	10	1
MPSA13	MPSA63	30	500	10K	—	100	1.5	100	0.1	125	10	1
BC517	—	30	1000	30K	—	20	1.0	100	0.1	200 <sup>(1)</sup>	10	17

**Table 4. Plastic-Encapsulated High-Current Transistors**

The following table is a listing of devices that are capable of handling a higher current range for small-signal transistors.

NPN	PNP	V <sub>(BR)CEO</sub> Volts Min	f <sub>T</sub> @ I <sub>C</sub>		I <sub>C</sub> mA Max	hFE @ I <sub>C</sub>			V <sub>CE(sat)</sub> @ I <sub>C</sub> & I <sub>B</sub>			Style
			MHz Min	mA		Min	Max	mA	Volts Max	mA	mA	

**Case 29-05 — TO-226AE (1-WATT TO-92)**

MPS6715	MPS6727	40	—	—	1000	50	—	1000	0.5	1000	100	1
<b>MPSW01A</b>	<b>MPSW51A</b>	40	50	50	1000	50	—	1000	0.5/0.7	1000	100	1

**Case 29-04 — TO-226AA (TO-92)**

BC489	BC490	80	200/150 <sup>(1)</sup>	50	1000	60	400	100	0.3/0.5	1000	100	17
BC639	BC640	80	60	10	500	40	160	150	0.5	500	50	14
<b>MPS651</b>	<b>MPS751</b>	60	75	50	2000	75	—	1000	0.5	2000	200	1
MPS650	MPS750	40	75	50	2000	75	—	1000	0.5	2000	200	1
BC368	BC369	20	65	10	1000	60	—	1000	0.5	1000	100	1

(1) Typical

Devices listed in bold, italic are Motorola preferred devices.

## Plastic-Encapsulated Transistors (continued)

**Table 5. Plastic-Encapsulated High-Voltage Amplifier Transistors**

These high-voltage transistors are designed for driving neon bulbs and indicator tubes, for direct line operation, and for other applications requiring high-voltage capability at relatively low collector current. These devices are listed in order of decreasing breakdown voltage ( $V_{(BR)CEO}$ ).

Device Type	$V_{(BR)CEO}$ Volts Min	$I_C$ Amp Max	$h_{FE} @ I_C$		$V_{CE(sat)} @ I_C \& I_B$			$f_T @ I_C$		Style
			Min	mA	Volts Max	mA	mA	MHz Min	mA	

**Case 29-05 — TO-226AE (1-WATT TO-92) — NPN**

BDC05	300	0.5	40	25	2.0	20	2.0	60	10	14
<i>MPSW42</i>	300	0.5	40	30	0.5	20	2.0	50	10	1

**Case 29-05 — TO-226AE (1-WATT TO-92) — PNP**

<i>MPSW92</i>	300	0.5	25	30	0.5	20	2.0	50	10	1
---------------	-----	-----	----	----	-----	----	-----	----	----	---

**Case 29-04 — TO-226AA (TO-92) — NPN**

BF844	400	0.3	50	10	0.5	10	1.0	—	—	1
<i>MPSA44</i>	400	0.3	40	100	0.75	50	5.0	—	—	1
<i>2N6517</i>	350	0.5	30	30	0.3	10	1.0	40	10	1
BF393	300	0.5	40	10	0.2	20	2.0	50	10	1
<i>MPSA42</i>	300	0.5	40	10	0.5	20	2.0	50	10	1
<i>2N5551</i>	160	0.6	80	10	0.15	10	1.0	100	10	1

**Case 29-04 — TO-226AA (TO-92) — PNP**

BF493S	350	0.5	40	10	20	20	2.0	50	10	1
<i>2N6520</i>	350	0.5	30	30	0.3	10	1.0	40	10	1
<i>MPSA92</i>	300	0.5	40	10	0.5	20	2.0	50	10	1
2N6519	300	0.5	45	30	0.3	10	1.0	40	10	1
<i>2N5401</i>	150	0.6	60	10	0.2	10	1.0	100	10	1

**Case 29-04 — TO-226AA (TO-92)**

NPN	PNP	$V_{(BR)CEO}$ Volts Min	$I_C$ Amp Cont	$h_{FE} @ I_C$		$V_{CE(sat)} @ I_C \& I_B$			$f_T @ I_C$		Style
				Min	mA	Volts Max	mA	mA	MHz Min	mA	
BF420	BF421	300	0.5	50	25	2.0	20	2.0	60	10	14
BF422	BF423	250	0.5	50	25	2.0	20	2.0	60	10	14

Devices listed in bold, italic are Motorola preferred devices.



## Plastic-Encapsulated Transistors (continued)

**Table 6. Plastic-Encapsulated RF Transistors**

The RF transistors are designed for small-signal amplification from RF to VHF/UHF frequencies. They are also used as mixers and oscillators in the same frequency ranges.

Device Type	V <sub>(BR)CEO</sub> Volts Min	I <sub>C</sub> mA Max	hFE @ I <sub>C</sub>			f <sub>T</sub> MHz Typ	CRE/CRB pF Max	NF dB Typ	f MHz	Style
			Min	mA	V <sub>CE</sub> V					
<b>Case 29-04 — TO-226AA (TO-92) — NPN</b>										
BF224	30	50	30	7.0	10	600	0.28	2.5	100	21
MPSH24	30	50	30	8.0	10	400(2)	0.36	—	—	2
<b>MPSH20</b>	30	100	25	4.0	10	400(2)	0.65	—	—	2
MPSH07A(9)	30	25	20	3.0	10	400(2)	0.3	3.2(3)	100	1
MPS3866	30	400	10	5.0	5.0	500(2)	—	—	—	1
<b>MPSH11</b>	25	—	60	4.0	10	650(2)	0.9	—	—	2
<b>MPSH10</b>	25	—	60	4.0	10	650(2)	0.65	—	—	2
BF199	25	100	40	7.0	10	750	0.35	2.5	35	21
BF959	20	100	40	2.0	10	600(2)	0.65	3.0	200	21
<b>MPSH17</b>	15	—	25	5.0	10	800(2)	0.9	6.0(3)	200	2
<b>MPS918</b>	15	50	20	8.0	10	600(2)	1.7	6.0(3)	60	1
<b>MPS5179</b>	12	50	25	3.0	1.0	2000(3)	—	5.0(3)	200	1
MPS3563	12	50	20	8.0	10	800	1.7	6.0(3)	60	1
<b>MPS6595</b>	12	50	25	10	5.0	1200(2)	1.3	—	—	1

**Case 29-04 — TO-266AA (TO-92) — PNP**

<b>MPSH81</b>	20	50	60	5.0	10	600(2)	0.85	—	—	2
<b>MPSH69</b>	15	50	30	10	10	2000(2)	0.3	—	—	1

**Table 7. Plastic-Encapsulated High-Speed Saturated Switching Transistors**

Device Type	t <sub>on</sub> & t <sub>off</sub> @ I <sub>C</sub>			V <sub>(BR)CEO</sub> Volts Min	hFE @ I <sub>C</sub>		V <sub>CE(sat)</sub> @ I <sub>C</sub> & I <sub>B</sub>			f <sub>T</sub> @ I <sub>C</sub>		Style
	ns Max	ns Max	mA		Min	mA	Volts Max	mA	mA	MHz Min	mA	
<b>Case 29-04 — TO-226AA (TO-92) — NPN</b>												
2N4264	25	35	10	15	40	10	0.22	10	1.0	300	10	1
2N4265	25	35	10	12	100	10	0.22	10	1.0	300	10	1
<b>MPS3646</b>	18	28	300	15	30	30	0.2	30	3.0	350	30	1
<b>MPS2369A</b>	12	18	10	15	40	10	0.2	10	1.0	—	—	1
<b>Case 29-04 — TO-226AA (TO-92) — PNP</b>												
MPS4258	15	20	10	12	30	50	0.15	10	1.0	700	10	1

(2) Min

(3) Max

(9) AGC Capable

Devices listed in bold, italic are Motorola preferred devices.

## Plastic-Encapsulated Transistors (continued)

**Table 8. Plastic-Encapsulated Choppers**

Devices are listed in decreasing  $V_{(BR)EBO}$ .

Device Type	$V_{(BR)EBO}$ Volts Min	$I_C$ Amp <sup>(1)</sup> Max	$h_{FE} @ I_C$		$V_{CE(sat)} @ I_C \& I_B$			$f_T @ I_C$		Style
			Min	mA	Volts Max	mA	mA	MHz Min	mA	

**Case 29-04 — TO-226AA (TO-92) — NPN**

<b>MPSA17</b>	15	100	200	5.0	0.25	10	1.0	80	5.0	1
MPSA16	12	100	200	5.0	0.25	10	1.0	100	5.0	1

**Case 29-04 — TO-266AA (TO-92) — PNP**

<b>MPS404A</b>	-25	-150	30	-12	-0.2	-24	1.0	—	—	1
----------------	-----	------	----	-----	------	-----	-----	---	---	---

**Table 9. Plastic-Encapsulated Telecom Transistors**

These devices are special product ranges intended for use in telecom applications.

Device Type	$V_{(BR)CEO}$ Volts	$P_D$ mW 25°C Amb	$I_C$ mA Cont	$h_{FE} @ I_C @ V_{CE}$				$f_T$ MHz Min	Style
				Min	Max	mA	Volts		

**Case 29-04 — TO-226AA (TO-92) — NPN**

<b>P2N2222A</b>	40	625	600	75	—	10	10	300	17
PBF259,S <sup>(10)</sup>	300	625	500	25	—	1.0	10	40	1

**Case 29-04 — TO-226AA (TO-92) — PNP**

<b>P2N2907A</b>	60	625	600	100	—	10	10	200	17
PBF493,S <sup>(11)</sup>	300	625	500	40	—	1.0	10	40	1

(1) Typical

(10) "S" version,  $h_{FE}$  Min 60 @  $I_C = 20$  mA,  $V_{CE} = 10$  V.

(11) "S" version,  $h_{FE}$  Min 40 @  $I_C = 0.1$  mA,  $V_{CE} = 1.0$  V.

5

Devices listed in bold, italic are Motorola preferred devices.

# Plastic-Encapsulated Multiple Transistors

The manufacturing trend has been toward printed circuit board design with requirements for smaller packages with more functions. In the case of discrete components the use of the multiple device package helps to reduce board space requirements and assembly costs.

Many of the most popular devices are offered in the standard plastic DIP and surface mount IC packages. This includes small-signal NPN and PNP bipolar transistors, N-channel and P-channel FETs, as well as diode arrays.

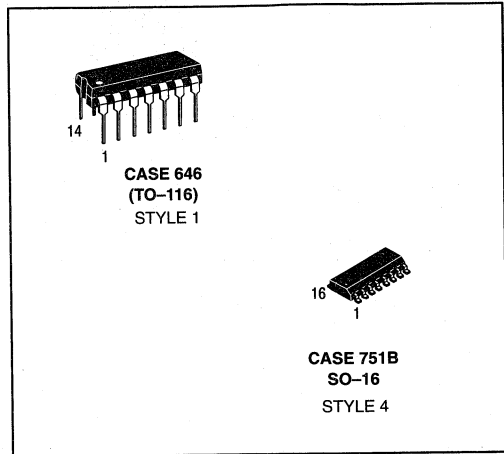

## Specification Tables

The following short form specifications include Quad and Dual transistors listed in alphanumeric order. Some columns denote two different types of data indicated by either **bold** or *italic* typeface. See key and headings for proper identification. This applies to Table 10 and 11 of this section only.

5

KEY											
TYPE NO.	ID	Ref. Point Pd Watts One Die Only	Subscript VCE Volts	IC Amp Max	Unit hFE @ IC Min   IC	fT MHz Min	Cob pF Max	hFE1 hFE2 ton ns Max	$\Delta V_{BE}$ mV Max	t <sub>off</sub> ns Max	Gp dB Min NF dB Max @ f VCE @ (sat) Volts Max IC & IC Unit IB
Alphanumeric listing type numbers					Common-emitter DC Current Gain.						Gp — Power Gain NF — Noise Figure f — Test Frequency AUD — 10-15 kHz Frequency Units: H — Hertz M — MHz K — kHz G — GHz
<b>Identification Code</b>					Units for test Current: A — ampere m — mA u — $\mu$ A						VCE(sat) — Collector-Emitter Saturation Voltage IC — Test Current Current Units: u — $\mu$ A m — mA A — Amp
<b>First Letter: Polarity</b> C — both types in multiple device N — NPN P — PNP <b>Second Letter: Use</b> A — General Purpose Amplifier E — Low Noise Audio Amplifier F — Low Noise RF Amplifier G — General Purpose Amplifier and Switch H — Tuned RF/IF Amplifier M — Differential Amplifier S — High Speed Switch D — Darlington					Current-Gain-Bandwidth Product						hFE1/hFE2 — Current Gain Ratio VBE — Differential Base Voltage   VBE1 — VBE2   Differential Amplifiers ton — turn-on time toff — turn-off time
Power Dissipation specified at 25°C. Single die rating. Ref. Point: A — Ambient Temperature C — Case Temperature					Rated Minimum Collector-Emitter Voltage Subscript letter identifies base termination listed below in order of preference. SUBSCRIPT: 0 — VCE0, open						Output Capacitance, common-base. Shown without distinction: Ccb — Collector-Base Capacitance Cre — Common-Emitter Reverse Transfer Capacitance

## Plastic-Encapsulated Multiple Transistors (continued)

**Table 10. Plastic-Encapsulated Multiple Transistors — Quad**

The following table is a listing of the most popular multiple devices available in the plastic DIP package. These devices are available in NPN, PNP, and NPN/PNP configurations. (See note.)

Device	ID	P <sub>D</sub> Watts One Die Only	V <sub>CE0</sub> Volts	I <sub>C</sub> Amp Max	hFE @ I <sub>C</sub>		f <sub>T</sub> MHz Min	C <sub>ob</sub> pF Max	hFE1	ΔV <sub>BE</sub> mV Max	G <sub>p</sub> dB Min	NF dB Max	@ f
					hFE2	t <sub>on</sub> ns Max			t <sub>off</sub> ns Max	V <sub>CE</sub> (sat) Volts Max		Typ <sup>(1)</sup> @ I <sub>C</sub>	I <sub>C</sub>

**Case 646 — TO-116**

<b>MPQ2222A</b>	NA	0.65	40	0.5	100	150 m	200	8.0	35(1)	285(1)	0.3	10	150 m
<b>MPQ2369</b>	NS	0.5	15	0.5	40	10 m	450	4.0	9.0(1)	15(1)	0.25	10	10 m
MPQ2483	NA	0.625	40	0.05	150	1.0 m	50					<b>3.0(1)</b>	<b>AUD</b>
<b>MPQ2484</b>	NA	0.625	40	0.05	300	1.0 m	50					<b>2.0(1)</b>	<b>AUD</b>
<b>MPQ2907A</b>	PA	0.65	60	0.6	100	150 m	200	8.0	45(1)	180(1)	0.4	10	150 m
<b>MPQ3467</b>	PS	0.75	40	1.0	20	500 m	125	25	40	90	0.5	10	500 m
<b>MPQ3725</b>	NS	1.0	40	1.0	25	500 m	250	10	35	60	0.45	10	500 m
MPQ3762	PS	0.75	40	1.5	35	150 m	150	15	50	120	0.55	10	500 m
MPQ3798	PA	0.625	40	0.05	150	0.1 m	60	4.0				<b>3.0(1)</b>	<b>AUD</b>
<b>MPQ3799</b>	PA	0.625	60	0.05	300	0.1 m	60	4.0				<b>2.0(1)</b>	<b>AUD</b>
<b>MPQ3904</b>	NG	0.5	40	0.2	75	10 m	250	4.0	37(1)	136(1)	0.2	10	10 m
<b>MPQ3906</b>	PG	0.5	40	0.2	75	10 m	200	4.5	43(1)	155(1)	0.25	10	10 m
MPQ6001	CG	0.65	30	0.5	40	150 m	200	8.0	30(1)	225(1)	0.4	10	150 m
<b>MPQ6002</b>	CG	0.65	30	0.5	100	150 m	200	8.0	30(1)	225(1)	0.4	10	150 m
MPQ6100A	CA	0.5	45	0.05	150	1.0 m	50	4.0				<b>4.0(1)</b>	<b>AUD</b>
MPQ6426	ND	0.5	30	0.5	10K	100 m	125	8.0	—	—	1.5	10	100 m
MPQ6501	CG	0.65	30	0.5	40	150 m	200	8.0	30(1)	225(1)	0.4	10	150 m
MPQ6502	CG	0.65	30	0.5	100	150 m	200	8.0	30(1)	225(1)	0.4	10	150 m
<b>MPQ6600A1</b>	CA	0.5	45	0.05	150	1.0 m	50	4.0	0.8	20	0.25	10	1.0 m
<b>MPQ6700</b>	CA	0.5	40	0.2	70	10 m	200	4.5			0.25	10	1.0 m
MPQ6842	CA	0.75	40	0.5	70	10 m	300	4.5	45	150	0.15	10	0.5 m
<b>MPQ7043</b>	NA	0.75	250	0.5	25	1.0 m	50	5.0			0.5	10	20 m
MPQ7042	NA	0.75	200	0.5	25	1.0 m	50	5.0			0.5	10	20 m
<b>MPQ7051</b>	CG	0.75	150	0.5	25	1.0 m	50	6.0			0.7	10	20 m
<b>MPQ7093</b>	PA	0.75	250	0.5	25	1.0 m	50	5.0			0.5	10	20 m

5

**Table 11. Plastic-Encapsulated Multiple Transistors — Quad Surface Mount**

The following table is a listing of the most popular multiple devices available in the plastic SOIC surface mount package. These devices are available in NPN, PNP, and NPN/PNP configurations.

Device	V <sub>(BR)CEO</sub>	V <sub>(BR)CBO</sub>	hFE @ I <sub>C</sub>		f <sub>T</sub> @ I <sub>C</sub>	
			Min	mA	MHz Min	mA

**Case 751B — SO-16**

<b>MMPQ2222A</b>	40	75	40	500	200	20
<b>MMPQ2369</b>	15	40	20	100	450	10
<b>MMPQ2907A</b>	50	60	50	500	200	50
<b>MMPQ3467</b>	40	40	20	500	125	50
<b>MMPQ3725</b>	40	60	25	500	250	50
<b>MMPQ3799</b>	60	60	300	0.5	60	1.0
<b>MMPQ3904</b>	40	60	75	10	250	10
<b>MMPQ3906</b>	40	40	75	10	200	10
<b>MMPQ6700(12)</b>	40	40	70	10	200	10

(1) Typical  
(12)NPN/PNP

NOTE: Some columns show 2 different types of data indicated by either **bold** or *italic* typefaces. See key and headings.

Devices listed in bold, italic are Motorola preferred devices.

## Plastic-Encapsulated Surface Mount Transistors

This section of the selector guide lists the small-signal plastic devices that are available for surface mount applications. These devices are encapsulated with the latest state-of-the-art mold compounds that enhance reliability and exhibit excellent performance in high temperature and high humidity environments. This package offers higher power dissipation capability for small-signal applications.

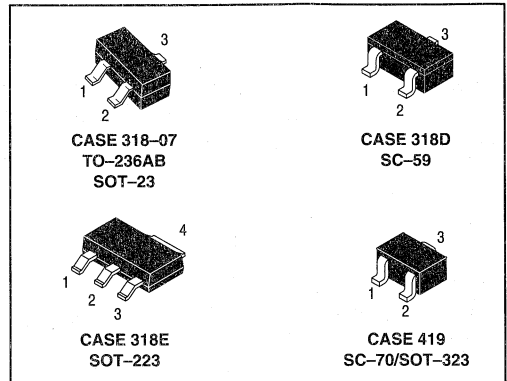

**Table 12. Plastic-Encapsulated Surface Mount General-Purpose Transistors**

The following tables are a listing of small-signal general-purpose transistors in the SOT-23 and SC-59 surface mount packages. These devices are intended for small-signal amplification for DC, audio, and lower RF frequencies. They also have applications as oscillators and general-purpose, low voltage switches.

**Pinout: 1-Base, 2-Emitter, 3-Collector**

Devices are listed in order of descending breakdown voltage.

Device	Marking	$V_{(BR)CEO}$	Min	$h_{FE} @ I_C$		mA	$f_T$ MHz Min
					Max		

**Case 318-07 — TO-236AB (SOT-23) — NPN**

MMBT8099LT1	KB	80	100	300	1.0	150
<b>BC846ALT1</b>	1A	65	110	220	2.0	100
<b>BC846BLT1</b>	1B	65	200	450	2.0	100
BC817-16LT1	6A	45	100	250	100	200
BC817-25LT1	6B	45	160	400	100	200
BC817-40LT1	6C	45	250	600	100	200
<b>BC847ALT1</b>	1E	45	110	220	2.0	100
<b>BC847BLT1</b>	1F	45	200	450	2.0	100
<b>BC847CLT1</b>	1G	45	420	800	2.0	100
<b>MMBT2222ALT1</b>	1P	40	100	300	150	200
<b>MMBT3904LT1</b>	1AM	40	100	300	10	200
<b>MMBT4401LT1</b>	2X	40	100	300	150	250
<b>BC848ALT1</b>	1J	30	110	220	2.0	100
<b>BC848BLT1</b>	1K	30	200	450	2.0	100
<b>BC848CLT1</b>	1L	30	420	800	2.0	100

**Case 318-07 — TO-236AB (SOT-23) — PNP**

MMBT8599LT1	2W	80	100	300	1.0	150
<b>BC856ALT1</b>	3A	65	125	250	2.0	100
<b>BC856BLT1</b>	3B	65	220	475	2.0	100
<b>MMBT2907ALT1</b>	2F	60	100	300	150	200
BC807-16LT1	5A	45	100	250	100	200

Devices listed in bold, italic are Motorola preferred devices.

5

## Plastic-Encapsulated Surface Mount Transistors (continued)

**Table 12. Plastic-Encapsulated Surface Mount General-Purpose Transistors (continued)**

Pinout: 1-Base, 2-Emitter, 3-Collector

Devices are listed in order of descending breakdown voltage.

Device	Marking	$V_{(BR)CEO}$	$h_{FE} @ I_C$			$f_T$ MHz Min
			Min	Max	mA	
<b>Case 318-07 — TO-236AB (SOT-23) — PNP</b>						
<i>BC807-25LT1</i>	5B	45	160	400	100	200
<i>BC807-40LT1</i>	5C	45	250	600	100	200
<i>BC857ALT1</i>	3E	45	125	250	2.0	100
<i>BC857BLT1</i>	3F	45	220	475	2.0	100
<i>MMBT3906LT1</i>	2A	40	100	300	10	250
<i>MMBT4403LT1</i>	2T	40	100	300	150	200
<i>BC858ALT1</i>	3J	30	125	250	2.0	100
<i>BC858BLT1</i>	3K	30	220	475	2.0	100
<i>BC858CLT1</i>	3L	30	420	800	2.0	100

**Case 318D — SC-59 — NPN**

<i>MSD601-RT1</i>	YR	25	210	340	2.0	150(1)
<i>MSD601-ST1</i>	YS	25	290	460	2.0	150(1)
<i>MSD602-RT1</i>	WR	25	120	240	150	200(1)
<i>MSD1328-RT1</i>	1DR	20	200	350	500	200(1)

**Case 318D — SC-59 — PNP**

<i>MSB709-RT1</i>	AR	25	210	340	2.0	100(1)
<i>MSB709-ST1</i>	AS	25	290	460	2.0	100(1)
<i>MSB710-QT1</i>	CQ	25	85	170	150	200(1)
<i>MSB710-RT1</i>	CR	25	120	240	150	200(1)

**Case 419-02 — SC-70/SOT-323 — NPN**

<i>MSD1819A-RT1</i>	ZR	50	210	340	2.0	100
---------------------	----	----	-----	-----	-----	-----

**Case 419-02 — SC-70/SOT-323 — PNP**

<i>MSB1218A-RT1</i>	AR	45	310	340	2.0	100
---------------------	----	----	-----	-----	-----	-----

(1) Typical

5

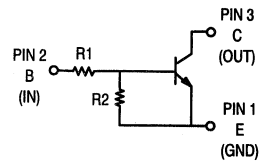

**Table 13. Plastic-Encapsulated Surface Mount Bias Resistor Transistors for General Purpose Applications**

These devices include bias resistors on the semiconductor chip with the transistor. See the BRT diagram for orientation of resistors.

Device		Marking		$V_{(BR)CEO}$ Volts (Min)	$h_{FE} @ I_C$		$I_C$ mA Max	$R_1$ Ohm	$R_2$ Ohm
NPN	PNP	NPN	PNP		Min	mA			
<b>Case 318D — SC-59</b>									
<i>MUN2211T1</i>	<i>MUN2111T1</i>	8A	6A	50	35	5.0	100	10K	10K
<i>MUN2212T1</i>	<i>MUN2112T1</i>	8B	6B	50	60	5.0	100	22K	22K
<i>MUN2213T1</i>	<i>MUN2113T1</i>	8C	6C	50	80	5.0	100	47K	47K
<i>MUN2214T1</i>	<i>MUN2114T1</i>	8D	6D	50	80	5.0	100	10K	47K

Devices listed in bold, italic are Motorola preferred devices.

## Plastic-Encapsulated Surface Mount Transistors (continued)

**Table 13. Plastic-Encapsulated Surface Mount Bias Resistor Transistors for General-Purpose Applications (continued)**

Pinout: 1-Base, 2-Emitter, 3-Collector

Device		Marking		V <sub>(BR)CEO</sub> Volts (Min)	hFE@ I <sub>C</sub>		I <sub>C</sub> mA Max	R <sub>1</sub> Ohm	R <sub>2</sub> Ohm
NPN	PNP	NPN	PNP		Min	mA			

**Case 318-07 — TO-236AB (SOT-23)**

<i>MMUN2211LT1</i>	<i>MMUN2111LT1</i>	A8A	A6A	50	35	5.0	100	10K	10K
<i>MMUN2212LT1</i>	<i>MMUN2112LT1</i>	A8B	A6B	50	60	5.0	100	22K	22K
<i>MMUN2213LT1</i>	<i>MMUN2113LT1</i>	A8C	A6C	50	80	5.0	100	47K	47K
<i>MMUN2214LT1</i>	<i>MMUN2114LT1</i>	A8D	A6D	50	80	5.0	100	10K	47K

**Case 419 — SC-70/SOT-323**

<i>MUN5211T1</i>	<i>MUN5111T1</i>	8A	6A	50	35	5.0	50	10K	10K
<i>MUN5212T1</i>	<i>MUN5112T1</i>	8B	6B	50	60	5.0	50	22K	22K
<i>MUN5213T1</i>	<i>MUN5113T1</i>	8C	6C	50	80	5.0	50	47K	47K
<i>MUN5214T1</i>	<i>MUN5114T1</i>	8D	6D	50	80	5.0	50	10K	47K

**Table 14. Plastic-Encapsulated Surface Mount Switching Transistors**

The following tables are a listing of devices intended for high-speed, low saturation voltage, switching applications. These devices have very fast switching times and low output capacitance for optimized switching performance.

Pinout: 1-Base, 2-Emitter, 3-Collector

Device	Marking	Switching Time (ns)		V <sub>(BR)CEO</sub>	hFE@ I <sub>C</sub>			f <sub>T</sub> MHz Min
		t <sub>on</sub>	t <sub>off</sub>		Min	Max	mA	

**Case 318-07 — TO-236AB (SOT-23) — NPN**

<i>MMBT2369LT1</i>	M1J	12	18	15	20	—	100	—
<i>BSV52LT1</i>	B2	12	18	12	40	120	10	400

**Case 318-07 — TO-236AB (SOT-23) — PNP**

<i>MMBT3640LT1</i>	2J	25	35	12	20	—	50	500
--------------------	----	----	----	----	----	---	----	-----

Pinout: 1-Emitter, 2-Base, 3-Collector

**Case 318D — SC-59 — NPN**

<i>MSC1621T1</i>	RB	20	40	20	40	180	1.0	200
------------------	----	----	----	----	----	-----	-----	-----

5

Devices listed in bold, italic are Motorola preferred devices.

## Plastic-Encapsulated Surface Mount Transistors (continued)

**Table 15. Plastic-Encapsulated Surface Mount VHF/UHF Amplifiers, Mixers, Oscillators**

The following table is a listing of devices intended for small-signal RF amplifier applications to VHF/UHF frequencies. These devices may also be used as VHF/UHF oscillators and mixers.

**Pinout: 1-Base, 2-Emitter, 3-Collector**

Device	Marking	$V_{(BR)CEO}$	$C_{cb}^{(13)}$ pF Max	$f_T @ I_C$	
				GHz Min	mA

**Case 318-07 — TO-236AB (SOT-23) — NPN**

<b>MMBTH10LT1</b>	3EM	25	0.7	0.65	4.0
MMBT918LT1	M3B	15	1.7 <sup>(14)</sup>	0.6	4.0
MMBTH24LT1	M3A	30	0.45	0.4	8.0

**Case 318-07 — TO-236AB (SOT-23) — PNP**

<b>MMBTH81LT1</b>	3D	20	0.85	0.6	5.0
<b>MMBTH69LT1</b>	M3J	15	0.35 <sup>(13)</sup>	2.0	10

**Pinout: 1-Emitter, 2-Base, 3-Collector**

**Case 318D — SC-59 — NPN**

<b>MSC2295-BT1</b>	VB	20	1.5 <sup>(13)</sup>	0.15	1.0
<b>MSC2295-CT1</b>	VC	20	1.5 <sup>(13)</sup>	0.15	1.0
<b>MSC2404-CT1</b>	UC	20	1.0 <sup>(13)</sup>	0.45	1.0
<b>MSC3130T1</b>	1S	10	—	1.4	5.0

**Case 318D — SC-59 — PNP**

<b>MSA1022-BT1</b>	EB	20	2.0 <sup>(13)</sup>	0.15	1.0
<b>MSA1022-CT1</b>	EC	20	2.0 <sup>(13)</sup>	0.15	1.0

<sup>(13)</sup>  $C_{re}$   
<sup>(14)</sup>  $C_{ob}$

**Table 16. Plastic-Encapsulated Surface Mount Choppers**

The following table is a listing of small-signal devices intended for chopper applications where a higher than normal  $V_{(BR)CEO}$  is required in the circuit application.

**Pinout: 1-Base, 2-Emitter, 3-Collector**

Device	Marking	$V_{(BR)CEO}$	$V_{(BR)EBO}$	$h_{FE} @ I_C$		mA
				Min	Max	

**Case 318-07 — TO-236AB (SOT-23) — PNP**

<b>MMBT404ALT1</b>	2N	35	25	30	400	12
--------------------	----	----	----	----	-----	----

**Table 17. Plastic-Encapsulated Surface Mount Darlington**

The following table is a listing of small-signal devices that have very high  $h_{FE}$  and input impedance characteristics. These devices utilize monolithic, cascade transistor construction.

**Pinout: 1-Base, 2-Emitter, 3-Collector**

Devices are listed in order of descending  $h_{FE}$ .

Device	Marking	$V_{(BR)CES}$	$V_{CE(sat)}$ Volts Max	$h_{FE} @ I_C$		mA
				Min	Max	

**Case 318-07 — TO-236AB (SOT-23) — NPN**

<b>MMBTA14LT1</b>	1N	30	1.5	20K	—	100
MMBTA13LT1	1M	30	1.5	10K	—	100

**Case 318-07 — TO-236AB (SOT-23) — PNP**

<b>MMBTA64LT1</b>	2V	30	1.5	20K	—	100
-------------------	----	----	-----	-----	---	-----

Devices listed in bold, italic are Motorola preferred devices.



## Plastic-Encapsulated Surface Mount Transistors (continued)

**Table 18. Plastic-Encapsulated Surface Mount Low-Noise Transistors**

The following table is a listing of small-signal devices intended for low noise applications in the audio range. These devices exhibit good linearity and are candidates for hi-fi and instrumentation equipment.

**Pinout: 1-Base, 2-Emitter, 3-Collector**

Devices are listed in order of ascending NF.

Device	Marking	NF dB Typ	$V_{(BR)CEO}$	$h_{FE@ IC}$			$f_T$ MHz Min
				Min	Max	mA	
<b>Case 318-07 — TO-236AB (SOT-23) — NPN</b>							
<i>MMBT5089LT1</i>	1R	2.0 <sup>(15)</sup>	25	400	—	10	50
MMBT2484LT1	1U	3.0 <sup>(15)</sup>	60	—	800	10	—
MMBT6428LT1	1KM	3.0	50	250	—	10	100
MMBT6429LT1	1L	3.0	45	500	—	10	100
<b>Case 318-07 — TO-236AB (SOT-23) — PNP</b>							
<i>MMBT5087LT1</i>	2Q	2.0 <sup>(15)</sup>	50	250	—	10	40

<sup>(15)</sup> Max

**Table 19. Plastic-Encapsulated Surface Mount High-Voltage Transistors**

The following table is a listing of small-signal high-voltage devices designed for direct line operation requiring high voltage breakdown and relatively low current capability.

**Pinout: 1-Base, 2-Emitter, 3-Collector**

Devices are listed in order of descending breakdown voltage.

Device	Marking	$V_{(BR)CEO}$	$h_{FE@ IC}$			$f_T$ MHz Min
			Min	Max	mA	
<b>Case 318-07 — TO-236AB (SOT-23) — NPN</b>						
<i>MMBT6517LT1</i>	1Z	350	15	—	100	40
<i>MMBTA42LT1</i>	1D	300	40	—	30	50
<i>MMBT5551LT1</i>	G1	160	30	—	50	100
<b>Case 318-07 — TO-236AB (SOT-23) — PNP</b>						
<i>MMBT6520LT1</i>	2Z	350	15	—	100	40
<i>MMBTA92LT1</i>	2D	300	25	—	30	50
<i>MMBT5401LT1</i>	2L	150	50	—	50	100

**Table 20. Plastic-Encapsulated Surface Mount Drivers**

The following is a listing of small-signal devices intended for medium voltage driver applications at fairly high current levels.

**Pinout: 1-Base, 2-Emitter, 3-Collector**

Device	Marking	$V_{(BR)CEO}$	$h_{FE@ IC}$			$f_T$ MHz Min
			Min	Max	mA	
<b>Case 318-07 — TO-236AB (SOT-23) — NPN</b>						
<i>MMBTA06LT1</i>	1GM	80	100	—	100	100
BSS64LT1	AM	80	20	—	10	50
<b>Case 318-07 — TO-236AB (SOT-23) — PNP</b>						
BSS63LT1	T1	100	30	—	25	50
<i>MMBTA56LT1</i>	2GM	80	100	—	100	50

Devices listed in bold, italic are Motorola preferred devices.

## Plastic-Encapsulated Surface Mount Transistors (continued)

**Table 21. Plastic-Encapsulated Surface Mount RF Transistors**

The following table is a listing of small-signal RF transistors intended for low-noise, high-power gain, Class A, AB or C amplifiers. These devices are used as pre-drivers in power amplifier applications.

**Pinout: 1-Base, 2-Emitter, 3-Collector**

Device	Marking	$f_T @ I_C @ V_{CE}$			NF @ $I_C @ V_{CE}$			MAG @ $I_C @ V_{CE} @ f$			MHz
		GHz Typ	mA	Volts	dB Typ	mA	Volts	dB Typ	mA	Volts	
<b>Case 318-07 — TO-236AB (SOT-23) — NPN</b>											
MMBR571LT1	7X	8.0	50	5.0	2.0	10	6.0	16.5	5.0	6.0	500
MMBR941LT1	7Y	8.0	15	6.0	2.1	5.0	6.0	8.5	5.0	6.0	2000
MMBR951LT1	7Z	8.0	30	8.0	2.1	5.0	6.0	7.5	5.0	6.0	2000
MMBR911LT1	7P	6.0	30	10	2.0	10	10	17	10	10	500
MMBR930LT1	7C	5.5	30	5.0	1.9	2.0	5.0	11	30	5.0	500
MMBR920LT1	7B	4.5	14	10	2.4	2.0	10	15	2.0	10	500
MMBR901LT1	7A	4.0	15	10	1.9	5.0	6.0	12	5.0	6.0	1000
BFR92LT1	P1	3.4	14	10	3.0	3.0	1.5	—	—	—	500
BFR93LT1	R1	3.4	30	5.0	2.5	2.0	5.0	—	—	—	30
MMBR931LT1	7D	3.0	1.0	1.0	4.3	0.25	1.0	10	0.25	1.0	1000
MMBR5179LT1	7H	1.4	5.0	6.0	4.5	1.5	6.0	15	5.0	6.0	200
MMBR2060LT1	7E	1.0	20	1.0	3.5	1.5	10	13	1.5	10	450
MMBR5031LT1	7G	1.0	5.0	6.0	2.5	1.0	6.0	17	1.0	6.0	450
MMBR2857LT1	7K	1.0	4.0	10	4.5	1.5	6.0	12.5	1.5	6.0	450
BFS17LT1	E1	1.0	2.0	5.0	5.0	2.0	5.0	—	—	—	30

**Case 318-07 — TO-236AB (SOT-23) — PNP**

MMBR536LT1	7R	5.5	20	5.0	4.5	10	5.0	14	10	5.0	500
MMBR4957LT1	7F	1.2	2.0	10	3.0	2.0	10	17	2.0	10	450

**Table 22. Plastic-Encapsulated Surface Mount General Purpose Amplifiers**

**Pinout: 1-Base, 2-Collector, 3-Emitter, 4-Collector**

Device	Marking	$V_{(BR)CEO}$	$h_{FE} @ I_C$		
			Min	Max	mA

**Case 318E — SOT-223 — NPN**

<b><i>BCP56T1</i></b>	BH	80	40	250	150
-----------------------	----	----	----	-----	-----

**Case 318E — SOT-223 — PNP**

**Pinout: 1-Gate, 2-Drain, 3-Source, 4-Drain**

<b><i>BCP53T1</i></b>	AH	80	40	25	150
-----------------------	----	----	----	----	-----

**Table 23. Plastic-Encapsulated Surface Mount Switching Transistors**

**Pinout: 1-Base, 2-Collector, 3-Emitter, 4-Collector**

Device	Marking	$t_{on}$	$t_{off}$	$V_{(BR)CEO}$	$h_{FE}$		$f_T$	
					Min	Max	@ $I_C$ (mA)	Min (MHz)

**Case 318E — SOT-223 — NPN**

<b><i>PZT222AT1</i></b>	P1F	35	285	40	100	300	20	300
-------------------------	-----	----	-----	----	-----	-----	----	-----

**Case 318E — SOT-223 — PNP**

<b><i>PZT290AT1</i></b>	P2F	45	100	60	100	300	50	200
-------------------------	-----	----	-----	----	-----	-----	----	-----

Devices listed in bold, italic are Motorola preferred devices.

## Plastic-Encapsulated Surface Mount Transistors (continued)

**Table 24. Plastic-Encapsulated Surface Mount Darlingtons**  
Pinout: 1-Base, 2-Collector, 3-Emitter, 4-Collector

Device	Marking	V <sub>(BR)</sub> CER	V <sub>CE(sat)</sub> Max (V)	hFE		@ I <sub>C</sub> (mA)
				Min	Max	

**Case 318E — SOT-223 — NPN**

<i>BSP52T1</i>	AS3	80	1.3	2000	—	500
<i>PZTA14T1</i>	P1N	30	1.5	20k	—	100

**Case 318E — SOT-223 — PNP**

<i>BSP62T1</i>	BS3	90	1.3	2000	—	500
<i>PZTA64T1</i>	P2V	30	1.5	20k	—	100

**Table 25. Plastic-Encapsulated Surface Mount High-Voltage Transistors**  
Pinout: 1-Base, 2-Collector, 3-Emitter, 4-Collector

Device	Marking	V <sub>(BR)</sub> CEO	hFE		f <sub>T</sub>	
			Min	Max	@ I <sub>C</sub> (mA)	Min (MHz)

**Case 318E — SOT-223 — NPN**

<i>BSP19AT1</i>	SP19A	350	40	—	20	70
<i>PZTA42T1</i>	P1D	300	40	—	10	50
<i>BF720T1</i>	BF720	250	50	—	10	60
<i>BSP20AT1</i>	SP20A	250	40	—	20	70

**Case 318E — SOT-223 — PNP**

<i>PZTA96T1</i>	ZTA96	450	50	150	10	50
<i>PZTA92T1</i>	P2D	300	40	—	10	50
<i>BSP16T1</i>	BSP16	300	30	150	10	15
<i>BF721T1</i>	BF721	250	50	—	10	60

5

**Table 26. Plastic-Encapsulated Surface Mount High Current Transistors**  
Pinout: 1-Base, 2-Collector, 3-Emitter, 4-Collector

Device	Marking	V <sub>(BR)</sub> CEO	V <sub>CE(sat)</sub> Volts	hFE @ I <sub>C</sub>		
				Min	Max	mA

**Case 318E — SOT-223 — NPN**

<i>PZT651T1</i>	651	60	0.5	75	—	1000
<i>BCP68T1</i>	CA	20	0.5	60	—	1000

**Case 318E — SOT-223 — PNP**

<i>PZT751T1</i>	ZT751	60	0.5	75	—	1000
<i>BCP69T1</i>	CE	20	0.5	60	—	1000

Devices listed in bold, italic are Motorola preferred devices.

# Metal-Can Transistors

Metal-can packages are intended for use in industrial applications where harsh environmental conditions are encountered. These packages enhance reliability of the end products due to their resistance to varying humidity and extreme temperature ranges.

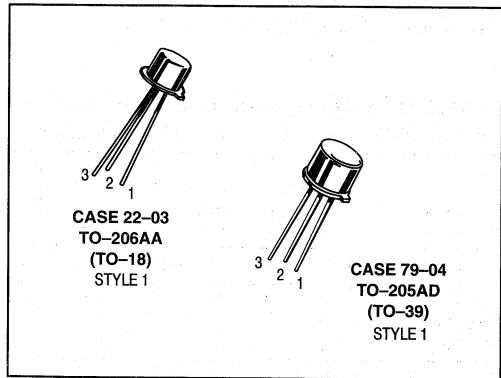

**Table 27. Metal-Can General-Purpose Transistors**

These transistors are designed for DC to VHF amplifier applications, general-purpose switching applications, and complementary circuitry. Devices are listed in decreasing order of  $V_{(BR)CEO}$  within each package group.

Device Type	$V_{(BR)CEO}$ Volts Min	$f_T @ I_C$		$I_C$ mA Max	$h_{FE} @ I_C$		
		MHz Min	mA		Min	Max	mA

**Case 22-03 — TO-206AA (TO-18) — NPN**

<b>2N720A</b>	80	50	50	150	40	120	150
<b>2N3700</b>	80	80	50	1000	50	—	500
BC107	45	150	10	200	110	450	2.0
BC107A	45	150	10	200	110	220	2.0
BC107B	45	150	10	200	200	450	2.0
BCY59-IX	45	125	10	200	250	460	2.0
BCY59-VIII	45	125	10	200	180	310	2.0
<b>2N2222A</b>	40	300	20	800	100	300	150
<b>2N3947</b>	40	300	10	200	100	300	10
BCY58-VIII	32	125	10	200	180	310	2.0
BC109C	25	150	10	200	420	800	2.0

**Case 22-03 — TO-206AA (TO-18) — PNP**

2N2906A	60	200	50	600	40	120	150
<b>2N2907A</b>	60	200	50	600	100	300	150
<b>2N3251A</b>	60	300	10	200	100	300	10
BC177B	45	200	10	200	180	460	2.0
BCY79-IX	45	180	10	200	250	460	2.0
BCY79-VIII	45	180	10	200	180	310	2.0

**Case 79-04 — TO-205AD (TO-39) — NPN**

<b>2N3019</b>	80	100	50	1000	100	300	150
2N3020	80	80	50	1000	40	120	150
2N1893	80	50	50	500	40	120	150
<b>2N2219A</b>	40	300	20	800	100	300	150
2N2218A	40	250	20	800	40	120	150

**Case 79-04 — TO-205AD (TO-39) — PNP**

2N4033	80	—	—	1000	25	—	1000
2N4036	65	60	50	1000	40	140	150
2N2904A	60	200	50	600	40	120	150
<b>2N2905A</b>	60	200	50	600	100	300	150
2N4032	60	—	—	1000	40	—	1000

Devices listed in bold, italic are Motorola preferred devices.

## Metal-Can Transistors (continued)

**Table 28. Metal-Can High-Gain/Low-Noise Transistors**

These transistors are characterized for high-gain and low-noise applications. Devices are listed in decreasing order of NF.

Device Type	NF Wideband dB Typ Max	$V_{(BR)CEO}$ Volts Min	$I_C$ mA Max	$h_{FE} @ I_C$			$f_T @ I_C$	
				Min	Max	$\mu A$ mA	MHz Min	mA

**Case 22-03 — TO-206AA (TO-18) — NPN**

<b>2N2484</b>	8.0(1)	60	50	100	500	10	15	0.05
2N930A	3.0	45	30	—	600	10	45	0.5
2N930	3.0	45	30	—	600	10	30	0.5

**Case 22-03 — TO-206AA (TO-18) — PNP**

<b>2N3964</b>	4.0	45	200	250	600	1.0(24)	50	0.5
<b>2N3799</b>	2.5	60	50	300	900	500	30	0.5

**Table 29. Metal-Can High-Voltage/High-Current Transistors**

The following table lists Motorola standard devices that have high collector-emitter breakdown voltage. Devices are listed in decreasing order of  $V_{(BR)CEO}$  within each package type.

Device Type	$V_{(BR)CEO}$ Volts Min	$I_C$ mA Max	$h_{FE} @ I_C$		$V_{CE(sat)} @ I_C \& I_B$			$f_T @ I_C$	
			Min	mA	Volts Max	mA	mA	MHz Min	mA

**Case 22-03 — TO-206AA (TO-18) — NPN**

<b>2N6431</b>	300	50	50	30	0.5	20	2.0	50	10
BSS73	300	500	40	30	1.0	50	5.0	50	20

**Case 22-03 — TO-206AA (TO-18) — PNP**

<b>2N6433</b>	300	500	30	30	0.5	20	20	50	10
BSS76	300	500	35	30	0.5	50	5.0	50	20
2N3497	120	100	40	10	0.35	10	1.0	150	20

**Case 79-04 — TO-205AD (TO-39) — NPN**

2N4927	250	50	20	30	2.0	30	3.0	30	10
2N3500	150	300	40	150	0.4	150	15	150	20
<b>2N3501</b>	150	300	100	150	0.4	150	15	150	20

**Case 79-04 — TO-205AD (TO-39) — PNP**

2N4931	250	50	20	30	5.0	10	1.0	20	20
2N3636	175	1000	50	50	0.5	50	5.0	150	30
2N3637	175	1000	100	50	0.5	50	5.0	200	30

(1) Typical

(24)<sub>T<sub>A</sub></sub> = 25°C

5

Devices listed in bold, italic are Motorola preferred devices.

## Metal-Can Transistors (continued)

**Table 30. Metal-Can Switching Transistors**

The following devices are intended for use in general-purpose switching and amplifier applications. Within each package group shown, the devices are listed in order of decreasing turn-on time ( $t_{on}$ ).

Device Type	$t_{on}$ & $t_{off}$ @ $I_C$			$V_{(BR)CEO}$ Volts Min	$I_C$ mA Max	$h_{FE}$ @ $I_C$		$V_{CE(sat)}$ @ $I_C$ @ $I_B$			$f_T$ MHz Min	$I_C$ mA
	ns Max	ns Max	mA			Min	mA	Volts Max	mA	mA		
<b>Case 22-03 — TO-206AA (TO-18) — NPN</b>												
2N4014	35	60	500	40	1000	35	500	0.52	500	50	300	50
<b>2N2369A</b>	12	18	10	15	200	40	10	0.2	10	1.0	500	10
BSX20	7.0	21	100	15	500	20	10	0.25	10	1.0	500	10
<b>Case 22-03 — TO-206AA (TO-18) — PNP</b>												
2N3546	40	30	50	12	200	25	50	0.25	50	5.0	700	10
<b>Case 79-04 — TO-205AD (TO-39) — NPN</b>												
<b>MM3725</b>	35	60	500	40	2000	35	500	0.52	500	50	300	50
<b>Case 79-04 — TO-205AD (TO-39) — PNP</b>												
<b>2N3467</b>	40	90	500	40	1000	40	500	0.5	500	50	175	50
2N3468	40	90	500	50	1000	25	500	0.6	500	50	150	50

5

Devices listed in bold, italic are Motorola preferred devices.

# Field-Effect Transistors

## JFETs

JFETs operate in the depletion mode. They are available in both P- and N-channel and are offered in both Through-hole and Surface Mount packages. Applications include general-purpose amplifiers, switches and choppers, and RF amplifiers and mixers. These devices are economical and very rugged. The drain and source are interchangeable on many typical FETs.

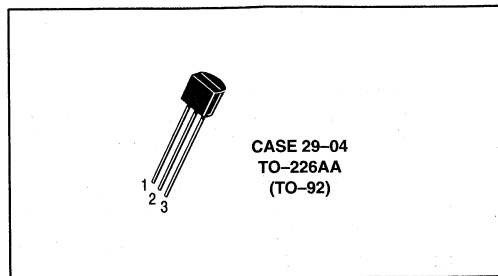

**Table 1. JFET Low-Frequency/Low-Noise**

The following table is a listing of small-signal JFETs intended for low-noise applications in the audio range. These devices exhibit good linearity and are candidates for hi-fi and instrumentation equipment.

Device	$R_e   Y_{fs}   @ f$		$R_e   Y_{os}   @ f$		$C_{iss}$ pF Max	$C_{rss}$ pF Max	$V_{(BR)GSS}$ $V_{(BR)GDO}$ Volts Min	$V_{GS(off)}$ Volts		$I_{DSS}$ mA		Style
	mmho Min	kHz	$\mu$ mho Max	kHz				Min	Max	Min	Max	

**Case 29-04 — TO-226AA (TO-92) — N-Channel**

J202	—	—	—	—	—	—	40	0.8	4.0	0.9	4.5	5
<b>2N5458</b>	1.5	1.0	50	1.0	7.0	3.0	25	1.0	7.0	2.0	9.0	5
J203	—	—	—	—	—	—	40	2.0	10	4.0	20	5
MPF3821	1.5	1.0	10	1.0	6.0	3.0	50	—	4.0	0.5	2.5	5
<b>2N5457</b>	1.0	1.0	50	1.0	7.0	3.0	25	0.5	6.0	1.0	5.0	5
<b>2N5459</b>	2.0	1.0	50	1.0	7.0	3.0	25	2.0	8.0	4.0	16	5
MPF3822	3.0	1.0	20	1.0	6.0	3.0	50	—	6.0	2.0	10	5

**Case 29-04 — TO-226AA (TO-92) — P-Channel**

<b>2N5460</b>	1.0	1.0	75	1.0	7.0	2.0	40	0.75	6.0	1.0	5.0	7
<b>2N5461</b>	1.5	1.0	75	1.0	7.0	2.0	40	1.0	7.5	2.0	9.0	7
<b>2N5462</b>	2.0	1.0	75	1.0	7.0	2.0	40	1.8	9.0	4.0	16	7

5

**Table 2. JFET High-Frequency Amplifiers**

The following is a listing of small-signal JFETs that are intended for hi-frequency applications. These are candidates for VHF/UHF oscillators, mixers and front-end amplifiers.

Device	$R_e   Y_{fs}   @ f$		$R_e   Y_{os}   @ f$		$C_{iss}$ pF Max	$C_{rss}$ pF Max	$NF @ R_G = 1K$		$V_{(BR)GSS}$ $V_{(BR)GDO}$ Volts Min	$V_{GS(off)}$ Volts		$I_{DSS}$ mA		Style
	mmho Min	MHz	$\mu$ mho Max	MHz			dB Max	f MHz		Min	Max	Min	Max	

**Case 29-04 — TO-226AA (TO-92) — N-Channel**

2N5669	1.6	100	100	100	7.0	3.0	2.5	100	25	1.0	6.0	4.0	10	5
MPF102	1.6	100	200	100	7.0	3.0	—	—	25	—	8.0	2.0	20	5
2N5668	1.0	100	50	100	7.0	3.0	2.5	100	25	0.2	4.0	1.0	5.0	5
<b>2N5484</b>	2.5	100	75	100	5.0	1.0	3.0	100	25	0.3	3.0	1.0	5.0	5
2N5670	2.5	100	150	100	7.0	3.0	2.5	100	25	2.0	8.0	8.0	20	5
<b>2N5485</b>	3.0	400	100	400	5.0	1.0	4.0	400	25	0.5	4.0	4.0	10	5
<b>2N5486</b>	3.5	400	100	400	5.0	1.0	4.0	400	25	2.0	6.0	8.0	20	5
J300	4.5	0.001	200	0.001	5.5	1.7	—	—	25	1.0	6.0	6.0	30	5
<b>J308</b>	12(1)	100	250(1)	100	7.5	2.5	1.5(1)	100	25	1.0	6.5	12	60	5
<b>J309</b>	12(1)	100	250(1)	100	7.5	2.5	1.5(1)	100	25	1.0	4.0	12	30	5
<b>J310</b>	12(1)	100	250(1)	100	7.5	2.5	1.5(1)	100	25	2.0	6.5	24	60	5

(1)Typical

Devices listed in bold, italic are Motorola preferred devices.

## JFETs (continued)

**Table 3. JFET Switches and Choppers**

The following is a listing of JFETs intended for switching and chopper applications.

Device	R <sub>DS(on)</sub> @ I <sub>D</sub>		V <sub>GS(off)</sub> Volts		I <sub>DSS</sub> mA		V <sub>(BR)GSS</sub> V <sub>(BR)GDO</sub> Volts Min	C <sub>iss</sub> pF Max	C <sub>rss</sub> pF Max	t <sub>on</sub> ns Max	t <sub>off</sub> ns Max	Style
	Ω Max	mA	Min	Max	Min	Max						
<b>Case 29-04 — TO-226AA (TO-92) — N-Channel</b>												
<b>MPF4856</b>	25	—	4.0	10	50	—	40	18	8.0	9.0	25	5
<b>MPF4859</b>	25	—	4.0	10	50	—	30	18	8.0	9.0	25	5
J111	30	—	3.0	10	20	—	35	28	5.0	—	—	5
<b>MPF4857</b>	40	—	2.0	6.0	20	100	40	18	8.0	10	50	5
<b>MPF4860</b>	40	—	2.0	6.0	20	100	30	18	8.0	10	50	5
J112	50	—	1.0	5.0	5.0	—	35	28	5.0	—	—	5
<b>MPF4392</b>	60	—	—	—	25	75	30	10	3.5	15	35	5
2N5639	60	1.0	—	(8.0)(1)	25	—	30	10	4.0	—	—	5
<b>MPF4858</b>	60	—	0.8	4.0	8.0	80	40	18	8.0	20	100	5
<b>MPF4861</b>	60	—	0.8	4.0	8.0	80	30	18	8.0	20	100	5
<b>MPF4393</b>	100	—	—	(12)(1)	5.0	30	30	10	3.5	15	55	5
2N5640	100	1.0	—	(6.0)(1)	5.0	—	30	10	4.0	18	45	5
J113	100	—	0.5	3.0	2.0	—	35	28	5.0	—	—	5
2N5555	150	—	—	1.0(16)	15	—	25	5.0	1.2	10	25	5
BF246A	35(1)	1.0	0.6	14	30	80	25	—	—	—	—	22
BF246B	50(1)	1.0	0.6	14	60	140	25	—	—	—	—	22
J110	18	—	0.5	4.0	10	—	25	—	—	—	—	5
<b>Case 29-04 — TO-226AA (TO-92) — P-Channel</b>												
MPF970	100	1.0	5.0	12	15	100	30	12	5.0	8.0	25	5
MPF971	250	1.0	1.0	7.0	2.0	50	30	12	5.0	10	120	5

(1) Typical  
(16) V<sub>GS(f)</sub>

5

Devices listed in bold, italic are Motorola preferred devices.





# MOSFETs

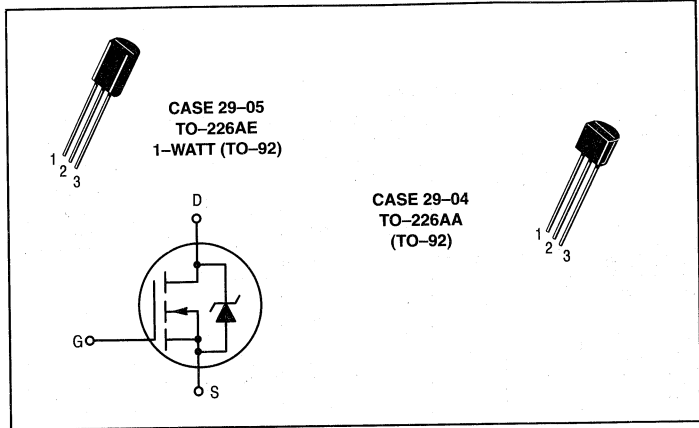

**Table 4. TMOS Switches and Choppers**

The following is a listing of small-signal TMOS devices that are intended for switching and chopper applications. These devices offer low  $R_{DS(on)}$  characteristics.

Device	$R_{DS(on)}$ @ $I_D$		$V_{GS(th)}$ Volts		$V_{(BR)DSS}$ Volts Min	$C_{iss}$ pF Max	$C_{rss}$ pF Max	$t_{on}$ ns Max	$t_{off}$ ns Max	Style
	$\Omega$ Max	A	Min	Max						

**Case 29-05 — TO-226AE (1-WATT TO-92) — N-Channel**

<b>MPF930</b>	1.4	1.0	1.0	3.5	35	70(1)	20(1)	15	15	22
<b>MPF960</b>	1.7	1.0	1.0	3.5	60	70(1)	20(1)	15	15	22
<b>MPF6659</b>	1.8	1.0	0.8	2.0	35	30(1)	4(1)	5.0	5.0	22
<b>MPF990</b>	2.0	1.0	1.0	3.5	90	70(1)	20(1)	15	15	22
<b>MPF6660</b>	3.0	1.0	0.8	2.0	60	30(1)	4(1)	5.0	5.0	22
<b>MPF6661</b>	4.0	1.0	0.8	2.0	90	30(1)	4(1)	5.0	5.0	22
<b>MPF910</b>	5.0	0.5	0.3	2.5	60	—	—	—	—	22
<b>VN10LM</b>	5.0	0.5	0.8	2.5	60	60	5.0	10	10	22

**Case 29-04 — TO-226AA (TO-92) — N-Channel**

<b>VN0300L</b>	1.2	1.0	0.8	2.5	60	100	25	30	30	22
<b>2N7000</b>	5.0	0.5	0.8	3.0	60	60	5.0	10	10	22
<b>BS170</b>	5.0	0.2	0.8	3.0	60	25(1)	3.0(1)	10	10	30
<b>VN0610LL</b>	5.0	0.5	0.8	2.5	60	60	5.0	10	10	22
<b>VN1706L</b>	6.0	0.5	0.8	2.0	170	125	20	8.0	18	22
<b>VN2406L</b>	6.0	0.5	0.8	2.0	240	125	20	8.0	23	22
<b>BSS89</b>	6.0	0.30	1.0	2.7	200	72(1)	3.0(1)	6.0(1)	12(1)	7
<b>BS107A</b>	6.4	0.25	1.0	3.0	200	60(1)	6.0(1)	15	15	30
<b>2N7008</b>	7.5	0.5	1.0	2.5	60	50	5.0	20	20	22
<b>VN2222LL</b>	7.5	0.5	0.6	2.5	60	60	5.0	10	10	22
<b>VN2410L</b>	10	0.5	0.8	2.0	240	125	20	8.0	23	22
<b>BS107</b>	14	0.2	1.0	3.0	200	60(1)	6.0(1)	15	15	30

(1)Typical

Devices listed in bold, italic are Motorola preferred devices.

5

## Surface Mount FETs

This section contains the FET plastic packages available for surface mount applications. Most of these devices are the most popular metal-can and insertion type parts carried over to the new surface mount packages.

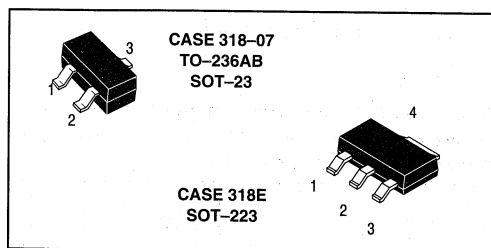

**Table 5. Surface Mount RF JFETs**

The following is a list of surface mount FETs which are intended for VHF/UHF RF amplifier applications.

**Pinout: 1–Drain, 2–Source, 3–Gate**

Device	Marking	NF		Y <sub>fs</sub> @ V <sub>DS</sub>		Volts	V <sub>(BR)GSS</sub>	Style
		dB Typ	f MHz	mmhos Min	mmhos Max			
<b>Case 318-07 — TO-236AB (SOT-23) — N-Channel</b>								
<b>MMBFJ309LT1</b>	6U	1.5	450	10	20	10	25	10
<b>MMBFJ310LT1</b>	6T	1.5	450	8.0	18	10	25	10
<b>MMBFU310LT1</b>	M6C	1.5	450	10	18	10	25	10
<b>MMBF4416LT1</b>	M6A	2 <sup>(3)</sup>	100	4.5	7.5	15	30	10
<b>MMBF5484LT1</b>	M6B	2.0	100	3.0	6.0	15	25	10
<b>MMBF5486LT1</b>	6H	2.0	100	4.0	8.0	15	25	10

**Table 6. Surface Mount General-Purpose JFETs**

The following table is a listing of surface mount small-signal general purpose FETs. These devices are intended for small-signal amplification for DC, audio, and lower RF frequencies. They also have applications as oscillators and general-purpose, low-voltage switches.

**Pinout: 1–Drain, 2–Source, 3–Gate**

Device	Marking	V <sub>(BR)GSS</sub>	Y <sub>fs</sub> @ V <sub>DS</sub>		Volts	I <sub>DSS</sub>		Style
			mmhos Min	mmhos Max		mA Min	mA Max	
<b>Case 318-07 — TO-236AB (SOT-23) — N-Channel</b>								
<b>MMBF5457LT1</b>	6D	25	1.0	5.0	15	1.0	5.0	10
<b>MMBF5459LT1</b>	6L	25	2.0	6.0	15	4.0	16	10
<b>Case 318-07 — TO-236AB (SOT-23) — P-Channel</b>								
<b>MMBF5460LT1</b>	M6E	40	1.0	4.0	15	1.0	5.0	10

<sup>(3)</sup>Max

5

Devices listed in bold, italic are Motorola preferred devices.

## Surface Mount FETs (continued)

**Table 7. Surface Mount Choppers/Switches JFETs**

The following is a listing of small-signal surface mount JFET devices intended for switching and chopper applications.  
Pinout: 1-Drain, 2-Source, 3-Gate

Device	Marking	R <sub>DS(on)</sub> Ohms Max	t <sub>off</sub> ns Max	V <sub>(BR)GSS</sub>	V <sub>GS(off)</sub>		I <sub>DSS</sub>		Style
					Volts Min	Volts Max	mA Min	mA Max	

**Case 318-07 — TO-236AB (SOT-23) — N-Channel**

<b>MMBF4856LT1</b>	AAA	25	25	40	4.0	10	50	—	10
<b>MMBF4391LT1</b>	6J	30	20	30	4.0	10	50	150	10
<b>MMBF4860LT1</b>	6F	40	50	30	2.0	6.0	20	100	10
<b>MMBF4392LT1</b>	6K	60	35	30	2.0	5.0	25	75	10
<b>MMBF4393LT1</b>	6G	100	50	30	0.5	3.0	5.0	30	10

**Case 318-07 — TO-236AB (SOT-23) — P-Channel**

<b>MMBFJ175LT1</b>	6W	125	—	-30	3.0	6.0	7.0	60	10
<b>MMBFJ177LT1</b>	6Y	300	—	-30	0.8	2.5	1.5	20	10

**Table 8. TMOS FETs**

The following is a listing of small-signal surface mount TMOS FETs which exhibit low R<sub>DS(on)</sub> characteristics.  
Pinout: 1-Gate, 2-Source, 3-Drain

Device	Marking	R <sub>DS(on)</sub> @ I <sub>D</sub>		V <sub>DSS</sub>	V <sub>GS(th)</sub>		Switching Time		Style
		Ohm	mA		Volts Min	Volts Max	t <sub>on</sub> ns	t <sub>off</sub> ns	

**Case 318-07 — TO-236AB (SOT-23) — N-Channel**

<b>MMBF170LT1</b>	6Z	5.0	200	60	0.8	3.0	10	10	21
<b>BSS123LT1</b>	SA	6.0	100	100	0.8	2.8	20	40	21
<b>2N7002LT1</b>	702	7.5	500	60	1.0	2.5	20	20	21

**Pinout: 1-Gate, 2-Drain, 3-Source, 4-Drain**

Device	Marking	R <sub>DS(on)</sub>		V <sub>DSS</sub>	V <sub>GS(th)</sub>		Switching Time		Style
		Ohm	mA		Volts Min	Volts Max	t <sub>on</sub> ns	t <sub>off</sub> ns	

**Case 318E — SOT-223 — N-Channel**

<b>MMFT960T1</b>	FT960	1.7	1000	60	1.0	3.5	15	15	3
<b>MMFT6661T1</b>	T6661	4.0	1000	90	0.8	2.0	5.0	5.0	3
<b>MMFT2406T1</b>	T2406	10	200	240	0.8	2.0	—	—	3
<b>MMFT107T1</b>	FT107	14	200	200	1.0	3.0	15	15	3

Devices listed in bold, italic are Motorola preferred devices.

# Tuning and Switching Diodes

## Tuning Diodes — Abrupt Junction

Motorola supplies voltage-variable capacitance diodes serving the entire range of frequencies from HF through UHF. Used in RF receivers and transmitters, they have a variety of applications, including:

- Phase-locked loop tuning systems
- Local oscillator tuning
- Tuned RF preselectors
- RF filters
- RF phase shifters
- RF amplifiers
- Automatic frequency control
- Video filters and delay lines
- Harmonic generators
- FM modulators

Two families of devices are available: Abrupt Junction and Hyper Abrupt Junction. The Abrupt Junction family includes devices suitable for virtually all tuned-circuit and narrow-range tuning applications throughout the spectrum.

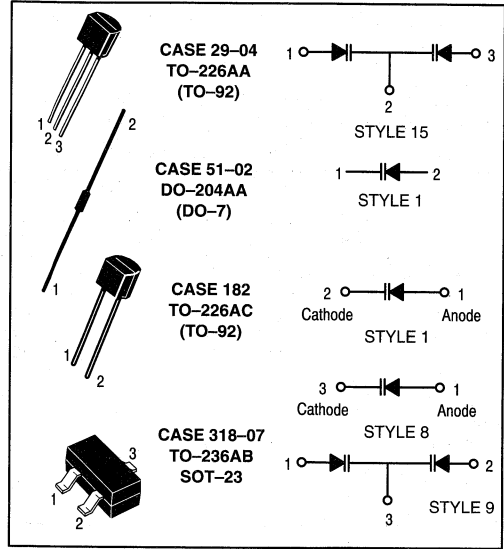

## Typical Characteristics

### Diode Capacitance versus Reverse Voltage

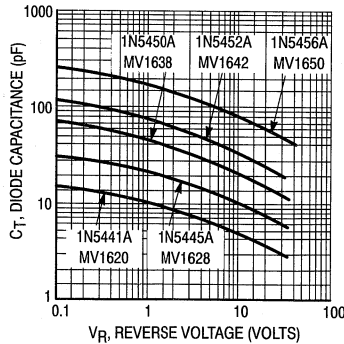
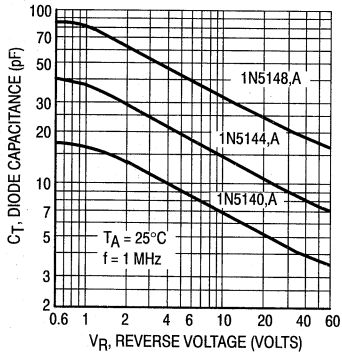

(See Tables 1 Thru 3)

5

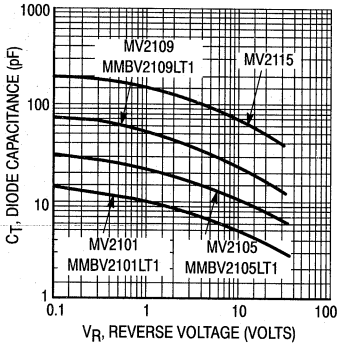

(See Tables 4 and 5)

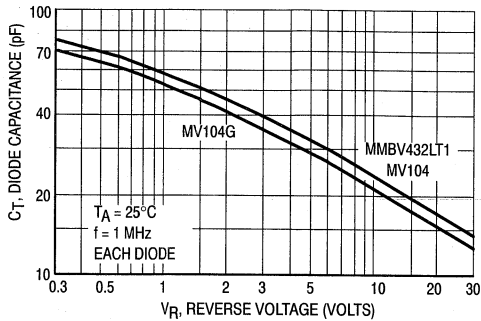

(See Table 6)

## Tuning Diodes — Abrupt Junction (continued)

**Table 1. General-Purpose Glass Abrupt Tuning Diodes  
High Q Capacitance Ratio @ 4.0 Volts/60 Volts**

The following is a listing of axial leaded, general-purpose, abrupt tuning diodes. These devices exhibit high Q characteristics.

Device(19)	$C_T @ V_R = 4.0 \text{ V}, 1.0 \text{ MHz}$			$V_{(BR)R}$ Volts	Cap Ratio C4/C60 Min	Q 4.0 V, 50 MHz Min
	pF Min	pF Nominal	pF Max			

**Case 51-02 — DO-204AA (DO-7)**

1N5139	6.1	6.8	7.5	60	2.7	350
1N5140	9.0	10	11	60	2.8	300
1N5141	10.8	12	13.2	60	2.8	300
1N5142	13.5	15	16.5	60	2.8	250
1N5143	16.2	18	19.8	60	2.8	250
1N5144	19.8	22	24.2	60	3.2	200
1N5145	24.3	27	29.7	60	3.2	200
1N5146	29.7	33	36.3	60	3.2	200
1N5147	35.1	39	42.9	60	3.2	200
1N5148	42.3	47	51.7	60	3.2	200

**Table 2. General-Purpose Glass Abrupt Tuning Diodes  
High Q Capacitance Ratio @ 2.0 Volts/30 Volts**

The following is a listing of axial leaded, general-purpose, abrupt tuning diodes. These devices exhibit very high Q characteristics.

Device(20)	$C_T @ V_R = 4.0 \text{ V}, 1.0 \text{ MHz}$			$V_{R(BR)R}$ Volts	Cap Ratio C2/C30 Min	Q 4.0 V, 50 MHz Min
	pF Min	pF Nominal	pF Max			

**Case 51-02 — DO-204AA (DO-7)**

1N5441A	6.1	6.8	7.5	30	2.5	450
1N5443A	9.0	10	11	30	2.6	400
1N5444A	10.8	12	13.2	30	2.6	400
1N5445A	13.5	15	16.5	30	2.6	400
1N5446A	16.2	18	19.8	30	2.6	350
1N5448A	19.8	22	24.2	30	2.6	350
1N5449A	24.3	27	29.7	30	2.6	350
1N5450A	29.7	33	36.3	30	2.6	350
1N5451A	35.1	39	42.9	30	2.6	300
1N5452A	42.3	47	51.7	30	2.6	250
1N5453A	50.4	56	61.6	30	2.6	200
1N5455A	73.8	82	90.2	30	2.7	175
1N5456A	90	100	110	30	2.7	175

(19) Suffix A = 5.0%

(20) Suffix B = 5.0%

5

## Tuning Diodes — Abrupt Junction (continued)

**Table 3. General-Purpose Glass Abrupt Tuning Diodes  
Capacitance Ratio @ 2.0 Volts/20 Volts**

The following is a listing of axial leaded, general-purpose, abrupt tuning diodes. These devices exhibit high Q characteristics.

Device	$C_T @ V_R = 4.0 \text{ V}, 1.0 \text{ MHz}$			$V_{R(BR)R}$ Volts	Cap Ratio C2/C20 Min	Q 4.0 V, 50 MHz Typ
	pF Min	pF Nominal	pF Max			
<b>Case 51-02 — DO-204AA (DO-7)</b>						
MV1620	6.1	6.8	7.5	20	2.0	300
MV1624	9.0	10	11	20	2.0	300
MV1626	10.8	12	13.2	20	2.0	300
MV1628	13.5	15	16.5	20	2.0	250
MV1630	16.2	18	19.8	20	2.0	250
MV1634	19.8	22	24.2	20	2.0	250
MV1636	24.3	27	29.7	20	2.0	200
MV1638	29.7	33	36.3	20	2.0	200
MV1640	35.1	39	42.9	20	2.0	200
MV1642	42.3	47	51.7	20	2.0	200
MV1644	50.4	56	61.6	20	2.0	150
MV1648	73.8	82	90.2	20	2.0	150
MV1650	90	100	110	20	2.0	150

**Table 4. General-Purpose Plastic Abrupt Tuning Diodes  
Capacitance Ratio @ 2.0 Volts/30 Volts**

The following is a listing of plastic package, general-purpose, abrupt tuning diodes. These devices exhibit high Q characteristics.

Device	$C_T @ V_R = 4.0 \text{ V}, 1.0 \text{ MHz}$			$V_{R(BR)R}$ Volts	Cap Ratio C4/C30 Min	Q 4.0 V, 50 MHz Typ
	pF Min	pF Nominal	pF Max			
<b>Case 182 — TO-226AC (TO-92) — 2-Lead</b>						
<i><b>MV2101</b></i>	6.1	6.8	7.5	30	2.5	400
MV2103	9.0	10	11	30	2.5	350
<i><b>MV2104</b></i>	10.8	12	13.2	30	2.5	350
MV2105	13.5	15	16.5	30	2.5	350
MV2107	19.8	22	24.2	30	2.5	300
<i><b>MV2108</b></i>	24.3	27	29.7	30	2.5	250
<i><b>MV2109</b></i>	29.7	33	36.3	30	2.5	200
<i><b>MV2111</b></i>	42.3	47	51.7	30	2.5	150
<i><b>MV2113</b></i>	61.2	68	74.8	30	2.5	150
MV2114	73.8	82	90.2	30	2.5	100
<i><b>MV2115</b></i>	90	100	110	30	2.6	100

5

Devices listed in bold, italic are Motorola preferred devices.

## Tuning Diodes — Abrupt Junction (continued)

**Table 5. Surface Mount Abrupt Tuning Diodes  
Capacitance Ratio @ 2.0 Volts/30 Volts**

The following is a listing of surface mount abrupt junction tuning diodes intended for general-purpose variable capacitance circuit applications.

Device	C <sub>T</sub> @ V <sub>R</sub> = 4.0 V, 1.0 MHz			V <sub>R(BR)R</sub> Volts	Cap Ratio C <sub>2</sub> /C <sub>30</sub> Min	Q 4.0 V, 50 MHz Typ
	pF Min	pF Nominal	pF Max			

**Case 318-07 — DO-236AB (SOT-23)**

<b>MMBV2101LT1</b>	6.1	6.8	7.5	30	2.5	400
MMBV2103LT1	9.0	10	11	30	2.5	350
MMBV2104LT1	10.8	12	13.2	30	2.5	350
<b>MMBV2105LT1</b>	13.5	15	16.5	30	2.5	350
MMBV2107LT1	19.8	22	24.2	30	2.5	300
MMBV2108LT1	24.3	27	29.7	30	2.5	250
<b>MMBV2109LT1</b>	29.7	33	36.3	30	2.5	200

**Table 6. Abrupt Tuning Diodes for FM Radio — Dual**

The following is a listing of abrupt tuning diodes that are available as dual units in a single package.

Device	C <sub>T</sub> @ V <sub>R</sub> ( <sup>22</sup> )			Cap Ratio C <sub>3</sub> /C <sub>30</sub> Min	Q 3.0 V, 50 MHz Min	V <sub>(BR)R</sub> Volts	Device Marking	Style
	pF Min	pF Max	Volts					

**Case 29-04 — TO-226AA (TO-92)**

<b>MV104</b>	37	42	3.0	2.5	100	32	—	15
--------------	----	----	-----	-----	-----	----	---	----

**Case 318-07 — TO-236AB (SOT-23)**

<b>MMBV432LT1</b>	43	48.1	2.0	1.5( <sup>21</sup> )	100	14	M4B	9
-------------------	----	------	-----	----------------------	-----	----	-----	---

(<sup>21</sup>)C<sub>2</sub>/C<sub>8</sub>

(<sup>22</sup>)Each Diode

5

Devices listed in bold, italic are Motorola preferred devices.

# Tuning Diodes — Hyper-Abrupt Junction

The Hyper-Abrupt family exhibits higher capacitance, and a much larger capacitance ratio. It is particularly well suited for wider-range applications such as AM/FM radio and TV tuning.

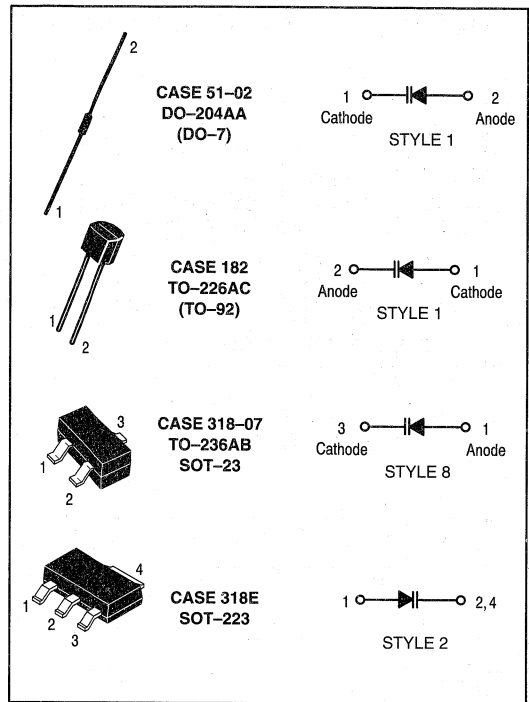

## Typical Characteristics

### Diode Capacitance versus Reverse Voltage

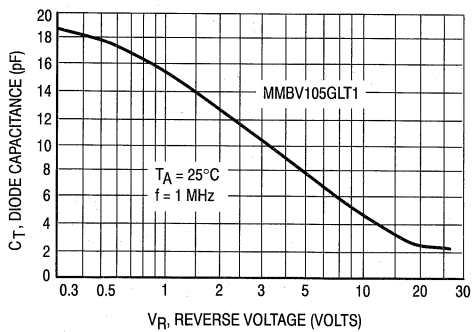

Figure 1. Diode Capacitance

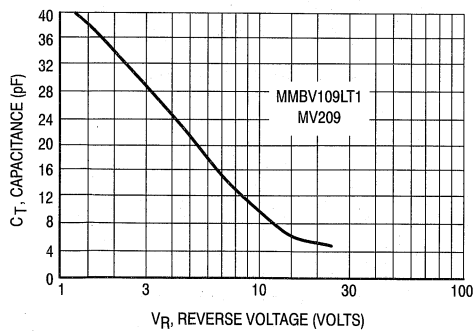

Figure 2. Diode Capacitance

5



## Tuning Diodes — Hyper-Abrupt Junction (continued)

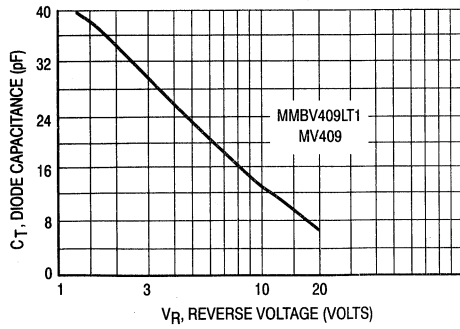

Figure 3. Diode Capacitance

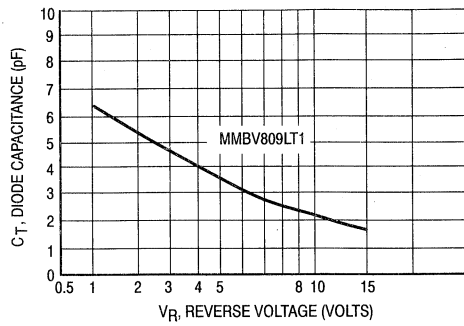

Figure 4. Diode Capacitance

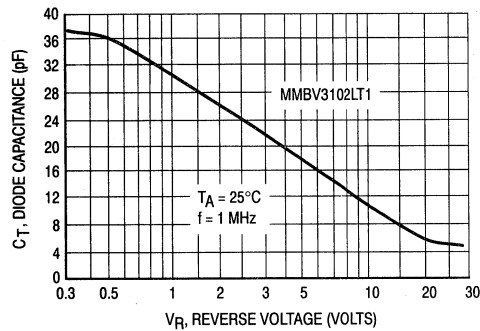

Figure 5. Diode Capacitance

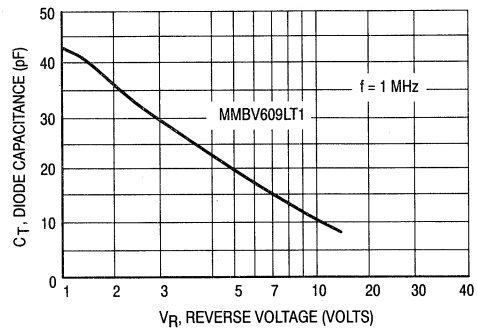

Figure 6. Diode Capacitance Each Die

5

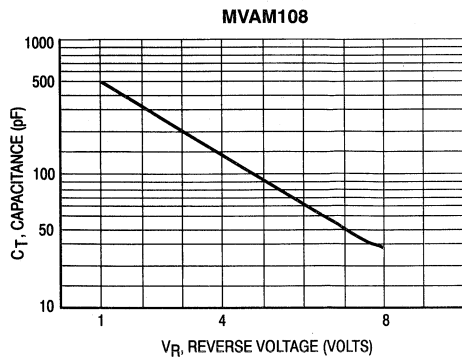

Figure 7. Capacitance versus Reverse Voltage

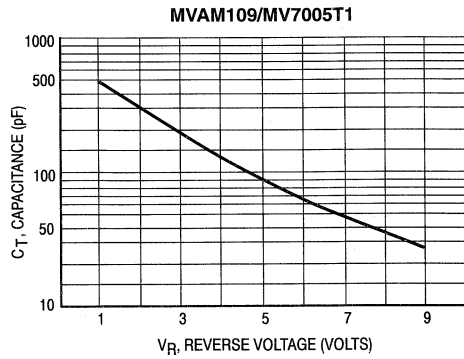

Figure 8. Capacitance versus Reverse Voltage

## Tuning Diodes — Hyper-Abrupt Junction (continued)

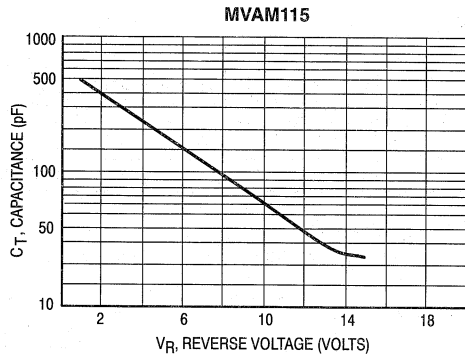

Figure 9. Capacitance versus Reverse Voltage

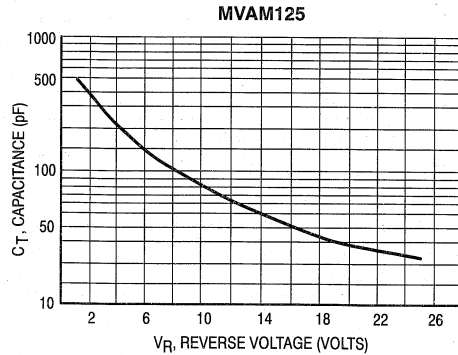

Figure 10. Capacitance versus Reverse Voltage

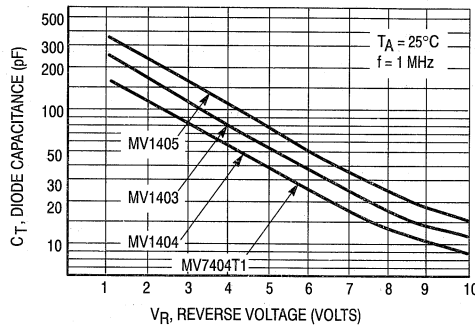

Figure 11. Diode Capacitance versus Reverse Voltage

Table 7. Hyper-Abrupt Tuning Diodes for Telecommunications — Single

The following is a listing of hyper-abrupt tuning diodes intended for high frequency, FM radio, and TV tuner applications.

Device	$C_T$ @ $V_R$ ( $f = 1.0$ MHz)			Cap Ratio @ $V_R$			Q		$V_{(BR)R}$ Volts	Device Marking	Case Style	CV Curve Fig
	pF Min	pF Max	Volts	Min	Max	Volts	3.0 V Min	50 MHz Max				
<b>Case 182 — TO-226AC (TO-92)</b>												
<i>MV209</i>	26	32	3.0	5.0	6.5	3/25	200	—	30	—	1	2
<i>MV409</i>	26	32	3.0	1.5	2.0	3/8	200	—	20	—	1	3
<b>Case 318-07 — TO-236AB (SOT-23)</b>												
<b><i>MMBV105GLT1</i></b>	1.8	2.8	25	4.0	6.0	3/25	200	—	30	M4E	8	1
<b><i>MMBV109LT1</i></b>	26	32	3.0	5.0	6.5	3/25	200	—	30	M4A	8	2
<b><i>MMBV409LT1</i></b>	26	32	3.0	1.5	2.0	3/8	200	—	20	X5	8	3
<b><i>MMBV809LT1</i></b>	4.5	6.1	2.0	1.8	2.6	2/8	300	—	20	5K	8	4
<b><i>MMBV3102LT1</i></b>	20	25	3.0	4.5	—	3/25	200	—	30	M4C	8	5

Devices listed in bold, italic are Motorola preferred devices.

## Tuning Diodes — Hyper-Abrupt Junction (continued)

**Table 8. Hyper-Abrupt Tuning Diodes for Communications — Dual**

Device	$C_T @ V_R (f = 1.0 \text{ MHz})$			Cap Ratio @ $V_R$			Q		$V_{(BR)R}$ Volts	Device Marking	Case Style	CV Curve Fig
	pF Min	pF Max	Volts	Min	Max	Volts	3.0 V Min	50 MHz Max				
<b>Case 318-07 — TO-236AB (SOT-23)</b>												
<b>MMBV609LT1</b>	26	32	3.0	1.8	2.4	3/8	250	—	20	5L	9	6

**Table 9. Hyper-Abrupt Tuning Diodes for Low Frequency Applications — Single**

The following is a listing of AM, hyper-abrupt tuning diodes that have a large capacity range and are designed for low frequency circuit applications.

Device	$C_T @ 1.0 \text{ MHz}$			Cap Ratio @ $V_R$		$V_{(BR)R}$ Volts	Style	CV Curve Figure
	pF Min	pF Max	Volts	Min	Volts			
<b>Case 182 — TO-226AC (TO-92)</b>								
<b>MVAM108</b>	440	560	1.0	15	1.0/8.0	12	1	7
<b>MVAM109</b>	400	520	1.0	12	1.0/9.0	15	1	8
<b>MVAM115</b>	440	560	1.0	15	1.0/15	18	1	9
<b>MVAM125</b>	440	560	1.0	15	1.0/25	28	1	10

**Table 10. Hyper-Abrupt High Capacitance Voltage Variable Diode — Surface Mount**

The following are high capacitance voltage variable diodes intended for low frequency applications and circuits requiring large tuning capacitance.

Device	$V_{(BR)R}$ Volts	$I_R$ nA	$C_T @ f = 1.0 \text{ MHz}$		Cap Ratio Min	Q Min	Style	CV Curve Figure
			Min pF	Max pF				
<b>Case 318E — SOT-223</b>								
Pinout: 1—Anode, 2, 4—Cathode, 3—NC								
<b>MV7005T1</b>	15	100	400	520	12 <sup>(26)</sup>	150 <sup>(28)</sup>	2	8
<b>MV7404T1</b>	12	100	96	144	10 <sup>(27)</sup>	200 <sup>(29)</sup>	2	11

**Table 11. Hyper-Abrupt High Capacitance Tuning Diodes — Axial Lead Glass Package**

Device	$C_T @ V_R$			Cap Ratio C2/C10 Min	Q 2.0 V, 1.0 MHz Min	$V_{(BR)R}$ Volts	Style	CV Curve Figure
	pF Min	pF Max	Volts					
<b>Case 51-02 — DO-204AA (DO-7)</b>								
<b>MV1404</b>	96	144	2.0	10	200	12	1	11
<b>MV1403</b>	140	210	2.0	10	200	12	1	11
<b>MV1405</b>	200	300	2.0	10	200	12	1	11

<sup>(26)</sup>  $V_R = 1.0 \text{ V}$ ,  $V_{V_R} = 9.0 \text{ V}$

<sup>(27)</sup>  $V_R = 2.0 \text{ V}$ ,  $V_{V_R} = 10 \text{ V}$

<sup>(28)</sup>  $V_R = 1.0 \text{ V}$ ,  $f = 1.0 \text{ MHz}$

<sup>(29)</sup>  $V_R = 2.0 \text{ V}$ ,  $f = 1.0 \text{ MHz}$

Devices listed in bold, italic are Motorola preferred devices.

# Hot-Carrier (Schottky) Diodes

Hot-Carrier diodes are ideal for VHF and UHF mixer and detector applications as well as many higher frequency applications. They provide stable electrical characteristics by eliminating the point-contact diode presently used in many applications.

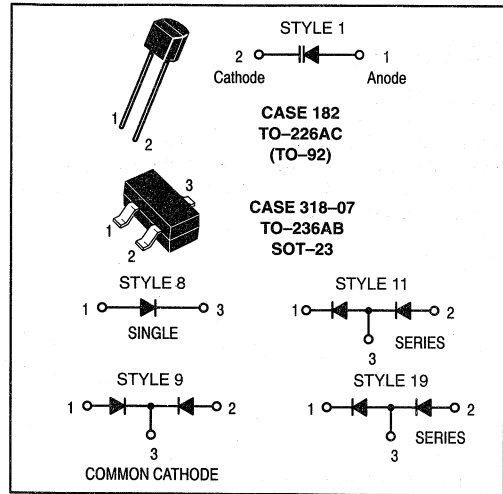

## Typical Characteristics Capacitance versus Reverse Voltage

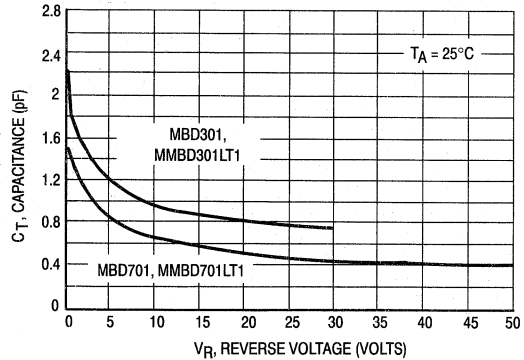
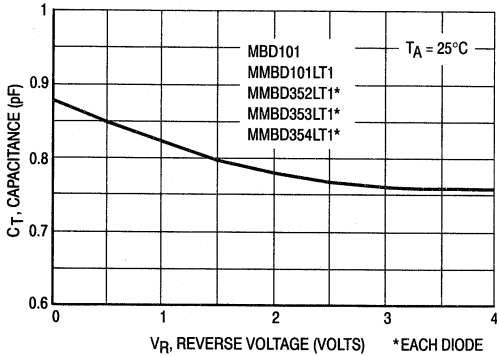

(See Table 12)

**Table 12. Hot-Carrier (Schottky) Diodes**

The following is a listing of hot carrier (Schottky) diodes that exhibit low forward voltage drop for improved circuit efficiency.

Device	V <sub>(BR)R</sub> Volts	C <sub>T</sub> @ V <sub>R</sub> pF Max	V <sub>F</sub> @ 10 mA Volts Max	I <sub>R</sub> @ V <sub>R</sub> nA Max	Minority Lifetime pS (TYP)	Device Marking	Style
<b>Case 182 — TO-226AC (TO-92)</b>							
<b>MBD701</b>	70	1.0 @ 20 V	1.0	200 @ 35 V	15	—	1
<b>MBD301</b>	30	1.5 @ 15 V	0.6	200 @ 25 V	15	—	1
<b>MBD101</b>	7.0	1.0 @ 0 V	0.6	250 @ 3.0 V	—	—	1
<b>Case 318-07 — TO-236AB (SOT-23)</b>							
<b>MMBD701LT1</b>	70	1.0 @ 20 V	1.0	200 @ 35 V	15	5H	8
<b>MMBD301LT1</b>	30	1.5 @ 15 V	0.6	200 @ 25 V	15	4T	8
<b>MMBD101LT1</b>	7.0	1.0 @ 0 V	0.6	250 @ 3.0 V	—	4M	8
<b>MMBD352LT1</b> (23)	7.0	1.0 @ 0 V	0.6	250 @ 3.0 V	—	M5G	11
<b>MMBD353LT1</b> (23)	7.0	1.0 @ 0 V	0.6	250 @ 3.0 V	—	M4F	19
<b>MMBD354LT1</b> (23)	7.0	1.0 @ 0 V	0.6	250 @ 3.0 V	—	M6H	9

(23) Dual Diodes

Devices listed in bold, italic are Motorola preferred devices.

# Switching Diodes

Small-signal switching diodes are intended for low current switching and steering applications. Hot-Carrier, PIN and general-purpose diodes allow a wide selection for specific application requirements.

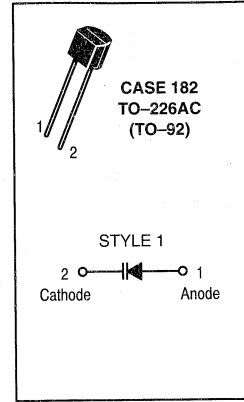
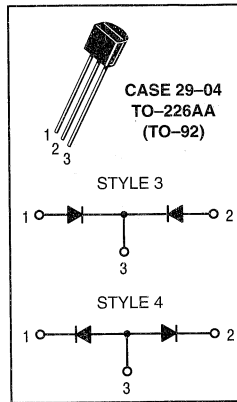

## Typical Characteristics

### Capacitance versus Reverse Voltage

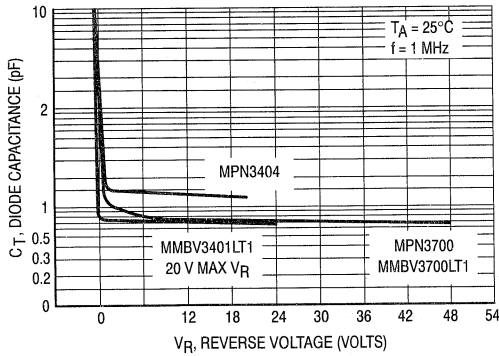

(See Table 13)

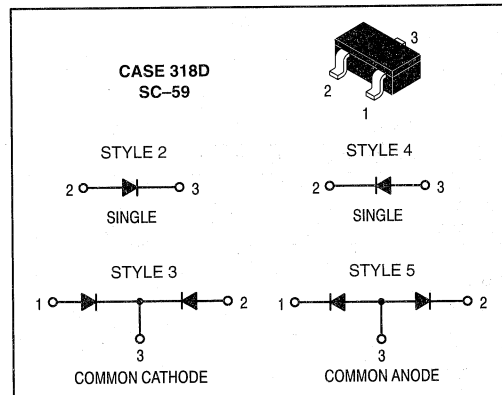
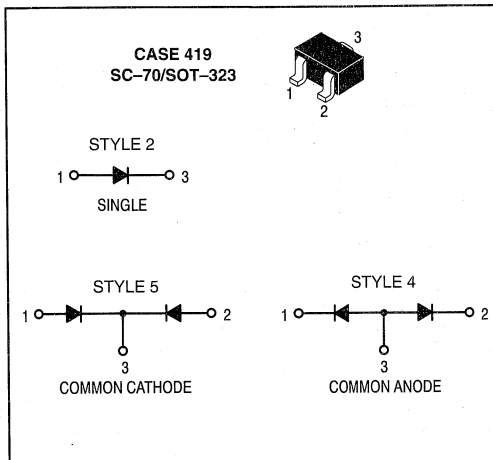
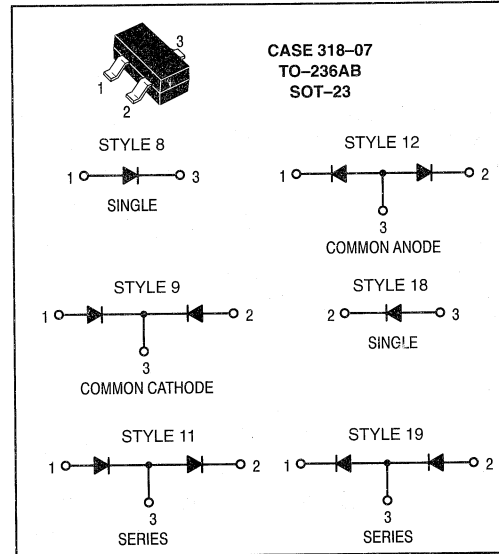

5

## Switching Diodes (continued)

**Table 13. PIN Switching Diodes**

The following PIN diodes are designed for VHF band switching and general-purpose low current switching applications.

Device	V(BR)R Volts Min	C <sub>T</sub> @ V <sub>R</sub> @ 1.0 MHz		I <sub>R</sub> @ V <sub>R</sub> nA Max	Series Resistance Ohm Max	Device Marking	Style
		pF Max	Volts				
<b>Case 182 — TO-226AC (TO-92)</b>							
MPN3700	200	1.0	20	0.1 @ 150	1.0 @ 10 mA	—	1
<b>MPN3404</b>	20	2.0	15	0.1 @ 25 V	0.85 @ 10 mA	—	1
<b>Case 318-07 — TO-236AB (SOT-23)</b>							
MMBV3700LT1	200	1.0	20	0.1 @ 150	1.0 @ 10 mA	4R	8
<b>MMBV3401LT1</b>	35	1.0	20	0.1 @ 25 V	0.7 @ 10 mA	4D	8

**Table 14. General-Purpose Signal and Switching Diodes — Single**

The following is a listing of small-signal switching diodes in surface mount packages. These diodes are intended for low current switching and signal steering applications.

Device	Marking	V(BR)R		I <sub>R</sub>		V <sub>F</sub>			C <sub>T</sub> (30)	t <sub>rr</sub>	Case Style
		Min Volts	@ I <sub>BR</sub> (μA)	Max (μA)	@ V <sub>R</sub> Volts	Min Volts	Max Volts	@ I <sub>F</sub> (mA)	Max (pF)	Max (ns)	
<b>Case 318-07 — TO-236AB (SOT-23)</b>											
BAS21LT1	JS	250	100	0.1	200		1.0	100	5.0	50	8
MMBD914LT1	5D	100	100	5.0	75		1.0	10	4.0	4.0	8
BAS16LT1	A6	75	100	1.0	75		1.0	50	2.0	6.0	8
MMBD6050LT1	5A	70	100	0.1	50	0.85	1.1	100	2.5	4.0	8
BAL99LT1	JF	70	100	2.5	70		1.0	50	1.5	6.0	18

Device	Marking	V(BR)R		I <sub>R</sub>		V <sub>F</sub>			C <sub>J</sub> (30)	t <sub>rr</sub> Max (ns)	Case Style
		Min Volts	@ I <sub>BR</sub> (μA)	Max (μA)	@ V <sub>R</sub> Volts	Min Volts	Max Volts	@ I <sub>R</sub> (mA)	Max (pF)		
<b>Case 318D — SC-59</b>											
<b>M1MA151AT1</b>	MA	40	100	0.1	35	—	1.2	100	2.0	3.0	4
<b>M1MA151KT1</b>	MH	40	100	0.1	35	—	1.2	100	2.0	3.0	2
<b>Case 419 — SC-70/SOT-323</b>											
<b>M1MA141KT1</b>	MH	40	100	0.1	35	—	1.2	100	2.0	3.0	2
<b>BAS16WT1</b>	A6	75	1.0	0.02	20	—	1.25	150	2.0	6.0	2
<b>M1MA142KT1</b>	MI	80	100	0.1	75	—	1.2	100	2.0	3.0	2

(30) V<sub>R</sub> = 0 V, f = 1.0 MHz

5

Devices listed in bold, italic are Motorola preferred devices.

## Switching Diodes (continued)

**Table 15. General-Purpose Signal and Switching Diodes — Dual**

The following is a listing of small-signal switching diodes in surface mount packages. These diodes are intended for low current switching and signal steering applications.

Device	Marking	V <sub>(BR)</sub> R		I <sub>R</sub>		V <sub>F</sub>			C <sub>T</sub> (30)	t <sub>rr</sub>	Case Style
		Min Volts	@ I <sub>BR</sub> (μA)	Max (μA)	@ V <sub>R</sub> Volts	Min Volts	Max Volts	@ I <sub>F</sub> (mA)	Max (pF)	Max (ns)	

**Case 318-07 — TO-236AB (SOT-23)**

<b>MMBD7000LT1</b>	M5C	100	100	0.3	50	0.75	1.1	100	1.5	4.0	11
MMBD2836LT1	A2	75	100	0.1	50	—	1.0	10	4.0	4.0	12
MMBD2838LT1	A6	75	100	0.1	50	—	1.0	10	4.0	4.0	9
<b>BAV70LT1</b>	A4	70	100	5.0	70	—	1.0	50	1.5	6.0	9
<b>BAV99LT1</b>	A7	70	100	2.5	70	—	1.0	50	1.5	4.0	11
<b>BAW56LT1</b>	A1	70	100	2.5	70	—	1.0	50	2.0	6.0	12
MMBD6100LT1	5BM	70	100	0.1	50	0.85	1.1	100	2.5	4.0	9
<b>BAV170LT1</b>	JX	70	100	0.005	70	—	1.0	10	2.0	3000	9
<b>BAV199LT1</b>	JY	70	100	0.005	70	—	1.0	10	2.0	3000	11
<b>BAW156LT1</b>	JZ	70	100	0.005	70	—	1.0	10	2.0	3000	12
BAV74LT1	JA	50	5.0	0.1	50	—	1.0	100	2.0	4.0	9
MMBD2835LT1	A3	35	100	0.1	30	—	1.0	10	4.0	4.0	12
MMBD2837LT1	A5	35	100	0.1	30	—	1.0	10	4.0	4.0	9

**Case 318D — SC-59**

<b>M1MA151WAT1</b>	MN	40	100	0.1	35	—	1.2	100	15	10	5
<b>M1MA151WKT1</b>	MT	40	100	0.1	35	—	1.2	100	2.0	3.0	3

**Case 419 — SC-70/SOT-323**

<b>M1MA142WKT1</b>	MU	80	100	0.1	75	—	1.2	100	2.0	3.0	5
<b>M1MA142WAT1</b>	MO	80	100	0.1	75	—	1.2	100	15	10	4
<b>BAW56WT1</b>	A1	70	100	2.5	70	—	1.0	50	2.0	6.0	4
<b>BAV70WT1</b>	A4	70	100	5.0	70	—	1.0	50	1.5	6.0	5
<b>M1MA141WKT1</b>	MT	40	100	0.1	35	—	1.2	100	2.0	3.0	5
<b>M1MA141WAT1</b>	MN	40	100	0.1	35	—	1.2	100	15	10	4

5

**Table 16. Low-Leakage Medium Speed Switching Diodes — Single**

Device	Marking	V <sub>(BR)</sub> R		I <sub>R</sub>		V <sub>F</sub>			C <sub>T</sub> (30)	t <sub>rr</sub>	Case Style
		Min Volts	@ I <sub>BR</sub> (μA)	Max (μA)	@ V <sub>R</sub> Volts	Min Volts	Max Volts	@ I <sub>F</sub> (mA)	Max (pF)	Max (ns)	

**Case 318-07 — TO-236AB (SOT-23)**

<b>BAS116LT1</b>	JV	75	100	0.005	75	—	1.0	10	2.0	3000	8
------------------	----	----	-----	-------	----	---	-----	----	-----	------	---

**Table 17. Low-Leakage Medium Speed Switching Diodes — Dual**

Device	Marking	V <sub>(BR)</sub> R		I <sub>R</sub>		V <sub>F</sub>			C <sub>T</sub> (30)	t <sub>rr</sub>	Case Style
		Min Volts	@ I <sub>BR</sub> (μA)	Max (μA)	@ V <sub>R</sub> Volts	Min Volts	Max Volts	@ I <sub>F</sub> (mA)	Max (pF)	Max (ns)	

**Case 318-07 — TO-236AB (SOT-23)**

<b>BAV170LT1</b>	JX	70	100	0.005	70	—	1.0	10	2.0	3000	9
<b>BAV199LT1</b>	JY	70	100	0.005	70	—	1.0	10	2.0	3000	11
<b>BAW156LT1</b>	JZ	70	100	0.005	70	—	1.0	10	2.0	3000	12

(30) V<sub>R</sub> = 0 V, f = 1.0 MHz

Devices listed in bold, italic are Motorola preferred devices.

# Multiple Switching Diodes

Multiple diode configurations utilize monolithic structures fabricated by the planar process. They are designed to satisfy fast switching requirements as in core driver and encoding/decoding applications where their monolithic configurations offer lower cost, higher reliability and space savings.

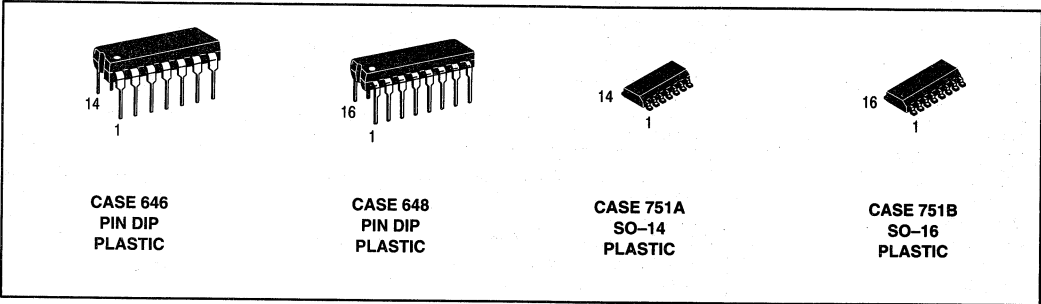

## Diode Array Diagrams

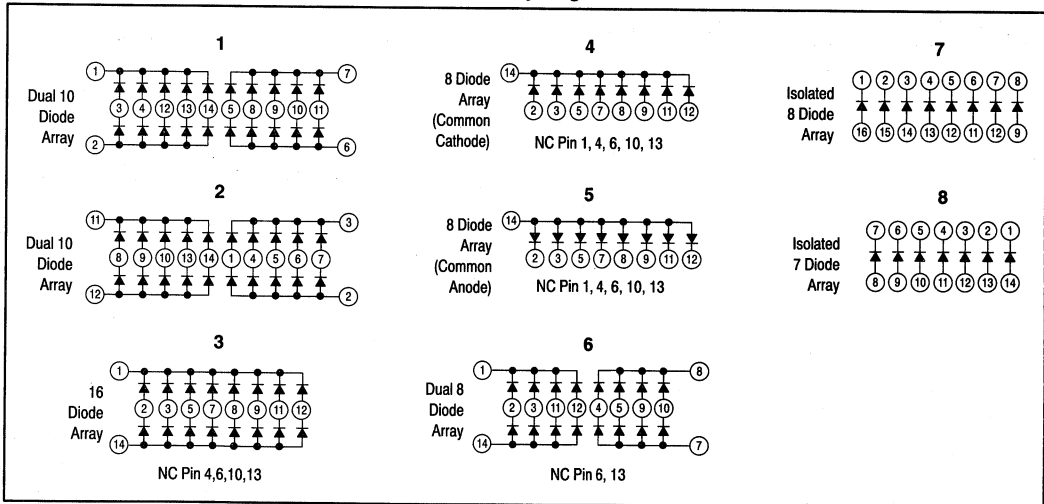

**5**



## Multiple Switching Diodes (continued)

Table 18. Diode Arrays

Case 646 — TO-116

Device	Function	Pin Connections Diagram Number
<i>MAD130P</i>	Dual 10 Diode Array	1
<i>MAD1103P</i>	16 Diode Array	3
MAD1105P	8 Diode Common Cathode Array	4
<i>MAD1107P</i>	Dual 8 Diode Array	6
<i>MAD1109P</i>	7 Isolated Diode Array	8

Case 648-08

<i>MAD1108P</i>	8 Isolated Diode Array	7
-----------------	------------------------	---

Case 751A — SO-14

<i>MMAD130</i>	Dual 10 Diode Array	2
<i>MMAD1103</i>	16 Diode Array	3
MMAD1105	8 Diode Common Cathode Array	4
MMAD1106	8 Diode Common Anode Array	5
<i>MMAD1107</i>	Dual 8 Diode Array	6
<i>MMAD1109</i>	7 Isolated Diode Array	8

Case 751B — SO-16

<i>MMAD1108</i>	8 Isolated Diode Array	7
-----------------	------------------------	---

5

Devices listed in bold, italic are Motorola preferred devices.

# TVS/Zeners

## Transient Voltage Suppressors

## Zener Regulator and Reference Diodes

---

### In Brief . . .

Motorola's standard TVS (Transient Voltage Suppressors) and Zener diodes comprise the largest inventoried line in the industry. Continuous development of improved manufacturing techniques have resulted in computerized diffusion and test, as well as critical process controls learned from surface-sensitive MOS fabrication. Resultant high yields lower factory costs. Check the following features for application to your specific requirements:

- Wide selection of package materials and styles:
  - Plastic (Surmetic) for low cost, mechanical ruggedness
  - Glass for high reliability, low cost
  - Surface Mount packages for state of the art designs
- Power Ratings from 0.25 to 5.0 Watts
- Breakdown voltages from 1.8 to 400 Volts in approximately 10% steps
- TVS from 24 to 1500 Watts and from 6.2 to 250 Volts
- ESD protection devices
- Available tolerances from 5% (low cost) to as tight as 1% (critical applications)
- Special selection of electrical characteristics available at low cost due to high-volume lines (check your Motorola sales representative for special quotations)
- UL Recognition on many TVS device types
- Tape and Reel options available on all axial leaded and surface mount types

	<b>Page</b>
TVS (Transient Voltage Suppressors) . . . . .	5.2-2
General-Purpose . . . . .	5.2-2
Axial Leaded for Through-hole Designs . . . . .	5.2-2
Surface Mount Packages . . . . .	5.2-9
Overvoltage Transient Suppressors . . . . .	5.2-15
Zener Diodes . . . . .	5.2-16
Voltage Regulator Diodes . . . . .	5.2-16
Notes — Axial Leaded Chart . . . . .	5.2-20
Notes — Surface Mount Chart . . . . .	5.2-23
Voltage Reference Diodes . . . . .	5.2-31
Current Regulator Diodes . . . . .	5.2-31

# TVS (Transient Voltage Suppressors)

## General-Purpose

Transient Voltage Suppressors are designed for applications requiring protection of voltage sensitive electronic devices in danger of destruction by high energy voltage transients. Many of the zener voltage regulator diodes listed in the previous charts are in fact used in circuits as transient voltage suppressors. The purpose of this section is to present the families of Motorola Zeners that are specified with the key transient voltage suppressor parameters and limits, e.g., maximum clamping voltage at maximum surge current rating and working peak reverse (stand-off) voltage.

Selection sequence:

1. Package type (axial or surface mount)
2. Peak surge power expected for the application
3. Working peak reverse stand-off voltage (or the breakdown voltage)
4. Maximum reverse clamping voltage

Consult the factory for special electrical selections if there is no standard device type available to fit the application.

## Axial Leaded for Through-hole Designs

Table 1. Peak Power Dissipation<sup>(3)</sup> (500 Watts @ 1 ms Surge – Figure 1)  
Case 59-04 — Mini Mosorb

5

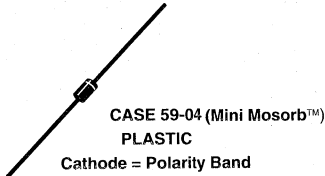

CASE 59-04 (Mini Mosorb™)  
PLASTIC  
Cathode = Polarity Band

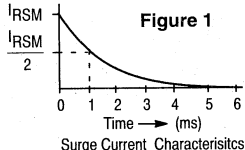

Figure 1  
Surge Current Characteristics

ELECTRICAL CHARACTERISTICS (T <sub>A</sub> = 25°C unless otherwise noted) V <sub>F</sub> = 3.5 V Max, I <sub>F</sub> = 35 A Pulse (except bidirectional devices).							
Working Peak Reverse Voltage V <sub>RWM</sub> (Volts)	Device <sup>(4)</sup>	Breakdown Voltage		@ I <sub>T</sub> Pulse (mA)	Maximum Reverse Leakage @ V <sub>RWM</sub> I <sub>R</sub> (μA)	Maximum Reverse Surge Current I <sub>RSM</sub> Figure 1 (Amps)	Maximum Reverse Voltage @ I <sub>RSM</sub> (Clamping Voltage) V <sub>RSM</sub> (Volts)
		V <sub>BR</sub> (Volts)	Min				
5	<b>SA5.0A</b>	6.4	7	10	600	54.3	9.2
6	<b>SA6.0A</b>	6.67	7.37	10	600	48.5	10.3
6.5	SA6.5A	7.22	7.98	10	400	44.7	11.2
7	SA7.0A	7.78	8.6	10	150	41.7	12
7.5	SA7.5A	8.33	9.21	1	50	38.8	12.9
8	SA8.0A	8.89	9.83	1	25	36.7	13.6
8.5	SA8.5A	9.44	10.4	1	5	34.7	14.4
9	SA9.0A	10	11.1	1	1	32.5	15.4
10	SA10A	11.1	12.3	1	1	29.4	17
11	<b>SA11A</b>	12.2	13.5	1	1	27.4	18.2
12	<b>SA12A</b>	13.3	14.7	1	1	25.1	19.9
13	SA13A	14.4	15.9	1	1	23.2	21.5
14	SA14A	15.6	17.2	1	1	21.5	23.2
15	<b>SA15A</b>	16.7	18.5	1	1	20.6	24.4
16	SA16A	17.8	19.7	1	1	19.2	26
17	SA17A	18.9	20.9	1	1	18.1	27.6

<sup>(3)</sup> Steady state power dissipation = 3 watt max rating

<sup>(4)</sup> For bidirectional types use CA suffix, **SA6.5CA**, **SA12CA**, **SA13CA** and **SA15CA** are Motorola preferred devices. Have cathode polarity band on each end. (Consult factory for availability).

Devices listed in bold, italic are Motorola preferred devices.

# TVS

## Axial Leaded for Through-hole Designs (continued)

Table 1. Peak Power Dissipation<sup>(3)</sup> (500 Watts @ 1 ms Surge – Figure 1)  
Case 59-04 — Mini Mosorb (continued)

ELECTRICAL CHARACTERISTICS (T <sub>A</sub> = 25°C unless otherwise noted) V <sub>F</sub> = 3.5 V Max, I <sub>F</sub> = 35 A Pulse (except bidirectional devices).							
Working Peak Reverse Voltage V <sub>RWM</sub> (Volts)	Device <sup>(4)</sup>	Breakdown Voltage		Maximum Reverse Leakage @ V <sub>RWM</sub> I <sub>R</sub> (μA)	Maximum Reverse Surge Current I <sub>RSM</sub> Figure 1 (Amps)	Maximum Reverse Voltage @ I <sub>RSM</sub> (Clamping Voltage) V <sub>RSM</sub> (Volts)	
		V <sub>BR</sub> (Volts)					
		Min	Max				
18	SA18A	20	22.1	1	1	29.2	
20	SA20A	22.2	24.5	1	1	32.4	
22	SA22A	24.4	26.9	1	1	35.5	
24	SA24A	26.7	29.5	1	1	38.9	
26	SA26A	28.9	31.9	1	1	42.1	
28	SA28A	31.1	34.4	1	1	45.4	
30	SA30A	33.3	36.8	1	1	48.4	
33	SA33A	36.7	40.6	1	1	53.3	
36	SA36A	40	44.2	1	1	58.1	
40	SA40A	44.4	49.1	1	1	64.5	
43	SA43A	47.8	52.8	1	1	69.4	
45	SA45A	50	55.3	1	1	72.7	
48	SA48A	53.3	58.9	1	1	77.4	
51	SA51A	56.7	62.7	1	1	82.4	
54	SA54A	60	66.3	1	1	87.1	
58	SA58A	64.4	71.2	1	1	93.6	
60	SA60A	66.7	73.7	1	1	96.8	
64	SA64A	71.1	78.6	1	1	103	
70	SA70A	77.8	86	1	1	113	
75	SA75A	83.3	92.1	1	1	121	
78	SA78A	86.7	95.8	1	1	126	
85	SA85A	94.4	104	1	1	137	
90	<b>SA90A</b>	100	111	1	1	146	
100	SA100A	111	123	1	1	162	
110	SA110A	122	135	1	1	177	
120	SA120A	133	147	1	1	193	
130	SA130A	144	159	1	1	209	
150	SA150A	167	185	1	1	243	
160	SA160A	178	197	1	1	259	
170	SA170A	189	209	1	1	275	

<sup>(3)</sup> Steady state power dissipation = 3 watt max rating

<sup>(4)</sup> For bidirectional types use CA suffix, **SA18CA** and **SA24CA** are Motorola preferred devices.  
Have cathode polarity band on each end. (Consult factory for availability).

5

Devices listed in bold, italic are Motorola preferred devices.

# TVS

## Axial Leded for Through-hole Designs (continued)

Table 2. Peak Power Dissipation<sup>(5)</sup> (600 Watts @ 1 ms Surge – Figure 1)  
Case 17 – Surmetic 40

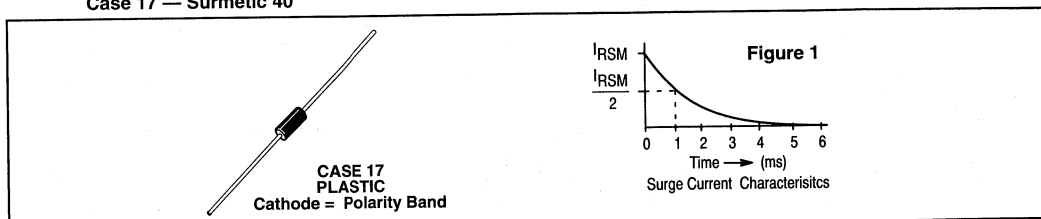

**ELECTRICAL CHARACTERISTICS** ( $T_A = 25^\circ\text{C}$  unless otherwise noted)  $V_F = 3.5\text{ V Max}$ ,  $I_F = 50\text{ A Pulse}$   
(except bidirectional devices).

Breakdown Voltage <sup>(6)</sup>		Device <sup>(4, 7)</sup>	Working Peak Reverse Voltage $V_{RWM}$ (Volts)	Maximum Reverse Leakage @ $V_{RWM}$ $I_R$ ( $\mu\text{A}$ )	Maximum Reverse Surge Current $I_{RSM}$ Figure 1 (Amps)	Maximum Reverse Voltage @ $I_{RSM}$ (Clamping Voltage) $V_{RSM}$ (Volts)
$V_{BR}$ (Volts)	@ $I_T$ Pulse (mA)					
Nom						
6.8	10	<b><i>P6KE6.8A</i></b>	5.8	1000	57	10.5
7.5	10	P6KE7.5A	6.4	500	53	11.3
8.2	10	P6KE8.2A	7.02	200	50	12.1
9.1	1	P6KE9.1A	7.78	50	45	13.4
10	1	P6KE10A	8.55	10	41	14.5
11	1	P6KE11A	9.4	5	38	15.6
12	1	P6KE12A	10.2	5	36	16.7
13	1	P6KE13A	11.1	5	33	18.2
15	1	<b><i>P6KE15A</i></b>	12.8	5	28	21.2
16	1	P6KE16A	13.6	5	27	22.5
18	1	P6KE18A	15.3	5	24	25.2
20	1	P6KE20A	17.1	5	22	27.7
22	1	P6KE22A	18.8	5	20	30.6
24	1	P6KE24A	20.5	5	18	33.2
27	1	P6KE27A	23.1	5	16	37.5
30	1	P6KE30A	25.6	5	14.4	41.4
33	1	P6KE33A	28.2	5	13.2	45.7
36	1	P6KE36A	30.8	5	12	49.9
39	1	P6KE39A	33.3	5	11.2	53.9
43	1	P6KE43A	36.8	5	10.1	59.3
47	1	P6KE47A	40.2	5	9.3	64.8
51	1	P6KE51A	43.6	5	8.6	70.1
56	1	P6KE56A	47.8	5	7.8	77
62	1	P6KE62A	53	5	7.1	85
68	1	P6KE68A	58.1	5	6.5	92
75	1	P6KE75A	64.1	5	5.8	103
82	1	P6KE82A	70.1	5	5.3	113
91	1	P6KE91A	77.8	5	4.8	125
100	1	P6KE100A	85.5	5	4.4	137
110	1	P6KE110A	94	5	4	152
120	1	P6KE120A	102	5	3.6	165
130	1	P6KE130A	111	5	3.3	179

(4) For bidirectional types use CA suffix, ***P6KE7.5CA*** and ***P6KE11CA*** are Motorola preferred devices. Have cathode polarity band on each end. (Consult factory for availability).

(5) Steady state power dissipation = 5 watt max rating.

(6) Breakdown voltage tolerance is  $\pm 5\%$  for A suffix.

(7) UL recognition for classification of protectors (QVGV2) under the UL standard for safety 497B and file #E116110 for entire series including CA suffixes.

Devices listed in bold, italic are Motorola preferred devices.

# TVS

## Axial Leaded for Through-hole Designs (continued)

Table 2. Peak Power Dissipation<sup>(5)</sup> (600 Watts @ 1 ms Surge – Figure 1)  
Case 17 — Surmetic 40 (continued)

ELECTRICAL CHARACTERISTICS ( $T_A = 25^\circ\text{C}$ unless otherwise noted) $V_F = 3.5\text{ V Max}$ , $I_F = 50\text{ A Pulse}$ (except bidirectional devices).						
Breakdown Voltage <sup>(6)</sup>		Device <sup>(4, 7)</sup>	Working Peak Reverse Voltage $V_{RWM}$ (Volts)	Maximum Reverse Leakage @ $V_{RWM}$ $I_R$ ( $\mu\text{A}$ )	Maximum Reverse Surge Current $I_{RSM}$ Figure 1 (Amps)	Maximum Reverse Voltage @ $I_{RSM}$ (Clamping Voltage) $V_{RSM}$ (Volts)
$V_{BR}$ (Volts)	@ $I_T$ Pulse (mA)					
Nom						
150	1	P6KE150A	128	5	2.9	207
160	1	P6KE160A	136	5	2.7	219
170	1	P6KE170A	145	5	2.6	234
180	1	P6KE180A	154	5	2.4	246
200	1	P6KE200A	171	5	2.2	274

(4) For bidirectional types use CA suffix. Have cathode polarity band on each end. (Consult factory for availability).

(5) Steady state power dissipation = 5 watt max rating.

(6) Breakdown voltage tolerance is  $\pm 5\%$  for A suffix.

(7) UL recognition for classification of protectors (QVGV2) under the UL standard for safety 497B and file #E116110 for entire series including CA suffixes.

# TVS

## Axial Leded for Through-hole Designs (continued)

Table 3. Peak Power Dissipation<sup>(5)</sup> (1500 WATTS @ 1 ms Surge – Figure 1)  
Case 41A — Mosorb

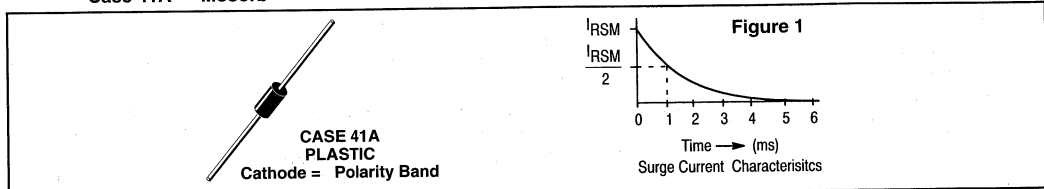

**ELECTRICAL CHARACTERISTICS** ( $T_A = 25^\circ\text{C}$  unless otherwise noted)  $V_F = 3.5\text{ V Max}$ ,  $I_F = 100\text{ A Pulse}$   
(C suffix denotes standard back to back bidirectional versions. Test both polarities)

Maximum Reverse Stand-Off Voltage $V_{RWM}$ (Volts)	JEDEC <sup>(6)</sup> Device	Device <sup>(8)</sup>	Breakdown Voltage		Maximum Reverse Leakage @ $V_{RWM}$ $I_R$ ( $\mu\text{A}$ )	Maximum Reverse Surge Current Figure 1 $I_{RSM}$ (Volts)	Maximum Reverse Voltage @ $I_{RSM}$ (Clamping Voltage) $V_{RSM}$ (Volts)	Clamping Voltage <sup>(9)</sup>	
			$V_{BR}$ Volts Min	@ $I_T$ Pulse (mA)				Peak Pulse Current @ $I_{pp1} = 1\text{ A}$ Figure 1 $V_{C1}$ (Volts max)	Peak Pulse Current @ $I_{pp2} = 10\text{ A}$ Figure 1 $V_{C2}$ (Volts max)
5	<b>1N5908</b>		6	1	300	120	8.5	7.6 @ 30 A	8 @ 60 A
5	<b>1N6373</b>	<i>ICTE-5/MPTE-5</i>	6	1	300	160	9.4	7.1	7.5
8	1N6374	<i>ICTE-8/MPTE-8</i>	9.4	1	25	100	15	11.3	11.5
8	1N6382	<i>ICTE-8C/MPTE-8C</i>	9.4	1	25	100	15	11.4	11.6
10	1N6375	<i>ICTE-10/MPTE-10</i>	11.7	1	2	90	16.7	13.7	14.1
10	1N6383	<i>ICTE-10C/MPTE-10C</i>	11.7	1	2	90	16.7	14.1	14.5
12	1N6376	<i>ICTE-12/MPTE-12</i>	14.1	1	2	70	21.2	16.1	16.5
12	1N6384	<i>ICTE-12C/MPTE-12C</i>	14.1	1	2	70	21.2	16.7	17.1
15	1N6377	<i>ICTE-15/MPTE-15</i>	17.6	1	2	60	25	20.1	20.6
15	1N6385	<i>ICTE-15C/MPTE-15C</i>	17.6	1	2	60	25	20.8	21.4
18	1N6378	<i>ICTE-18/MPTE-18</i>	21.2	1	2	50	30	24.2	25.2
18	1N6386	<i>ICTE-18C/MPTE-18C</i>	21.2	1	2	50	30	24.8	25.5
22	1N6379	<i>ICTE-22/MPTE-22</i>	25.9	1	2	40	37.5	29.8	32
22	1N6387	<i>ICTE-22C/MPTE-22C</i>	25.9	1	2	40	37.5	30.8	32
36	1N6380	<i>ICTE-36/MPTE-36</i>	42.4	1	2	23	65.2	50.6	54.3
36	1N6388	<i>ICTE-36C/MPTE-36C</i>	42.4	1	2	23	65.2	50.6	54.3
45	1N6381	<i>ICTE-45/MPTE-45</i>	52.9	1	2	19	78.9	63.3	70
45	1N6389	<i>ICTE-45C/MPTE-45C</i>	52.9	1	2	19	78.9	63.3	70

<sup>(5)</sup> Steady state power dissipation = 5 watts max rating.

<sup>(8)</sup> 1N6382 thru 1N6389 and C suffix ICTE/MPTE device types are bidirectional. Have cathode polarity band on each end. All other device types are unidirectional only. (Consult factory for availability)

<sup>(9)</sup> Clamping voltage peak pulse currents for 1N5908 are 30 Amps and 60 Amps.

Devices listed in bold, italic are Motorola preferred devices.

# TVS

## Axial Leaded for Through-hole Designs (continued)

Table 4. Peak Power Dissipation<sup>(5)</sup> (1500 Watts @ 1 ms Surge – Figure 1)  
Case 41A – Mosorb

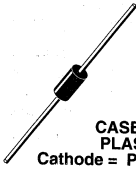

**CASE 41A  
PLASTIC**  
Cathode = Polarity Band

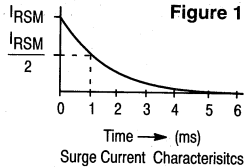

**Figure 1**  
Surge Current Characteristics

ELECTRICAL CHARACTERISTICS (T <sub>A</sub> = 25°C unless otherwise noted) V <sub>F</sub> = 3.5 V Max, I <sub>F</sub> = 100 A Pulse							
Breakdown Voltage <sup>(6)</sup>		JEDEC Device	Device <sup>(10, 11)</sup>	Working Peak Reverse Voltage V <sub>RWM</sub> (Volts)	Maximum Reverse Leakage @ V <sub>RWM</sub> I <sub>R</sub> (μA)	Maximum Reverse Surge Current Figure 1 I <sub>RSM</sub> (Amps)	Maximum Reverse Voltage @ I <sub>RSM</sub> (Clamping Voltage) V <sub>RSM</sub> (Volts)
V <sub>BR</sub> Volts	@ I <sub>T</sub> Pulse (mA)						
Nom							
6.8	10	<b>1N6267A</b>	1.5KE6.8A	5.8	1000	143	10.5
7.5	10	1N6268A	1.5KE7.5A	6.4	500	132	11.3
8.2	10	1N6269A	1.5KE8.2A	7.02	200	124	12.1
9.1	1	1N6270A	1.5KE9.1A	7.78	50	112	13.4
10	1	1N6271A	1.5KE10A	8.55	10	103	14.5
11	1	1N6272A	1.5KE11A	9.4	5	96	15.6
12	1	1N6273A	1.5KE12A	10.2	5	90	16.7
13	1	1N6274A	1.5KE13A	11.1	5	82	18.2
15	1	<b>1N6275A</b>	1.5KE15A	12.8	5	71	21.2
16	1	1N6276A	1.5KE16A	13.6	5	67	22.5
18	1	1N6277A	1.5KE18A	15.3	5	59.5	25.2
20	1	1N6278A	1.5KE20A	17.1	5	54	27.7
22	1	1N6279A	<b>1.5KE22A</b>	18.8	5	49	30.6
24	1	<b>1N6280A</b>	1.5KE24A	20.5	5	45	33.2
27	1	<b>1N6281A</b>	1.5KE27A	23.1	5	40	37.5
30	1	<b>1N6282A</b>	1.5KE30A	25.6	5	36	41.4
33	1	<b>1N6283A</b>	1.5KE33A	28.2	5	33	45.7
36	1	1N6284A	1.5KE36A	30.8	5	30	49.9
39	1	<b>1N6285A</b>	<b>1.5KE39A</b>	33.3	5	28	53.9
43	1	1N6286A	1.5KE43A	36.8	5	25.3	59.3
47	1	1N6287A	1.5KE47A	40.2	5	23.2	64.8
51	1	<b>1N6288A</b>	1.5KE51A	43.6	5	21.4	70.1
56	1	1N6289A	1.5KE56A	47.8	5	19.5	77
62	1	1N6290A	1.5KE62A	53	5	17.7	85
68	1	1N6291A	1.5KE68A	58.1	5	16.3	92
75	1	1N6292A	1.5KE75A	64.1	5	14.6	103
82	1	1N6293A	1.5KE82A	70.1	5	13.3	113
91	1	1N6294A	1.5KE91A	77.8	5	12	125
100	1	1N6295A	1.5KE100A	85.5	5	11	137
110	1	1N6296A	1.5KE110A	94	5	9.9	152
120	1	1N6297A	1.5KE120A	102	5	9.1	165
130	1	1N6298A	1.5KE130A	111	5	8.4	179

(5) Steady state power dissipation = 5 watts max rating.  
 (6) Breakdown voltage tolerance is ±5% for A suffix.  
 (10) For bidirectional types use CA suffix on 1.5KE series only. Have cathode polarity band on each end. (Consult factory for availability)  
 1N6267–6303A series do not have CA option since the CA is not included in EIA Registration.  
 (11) UL recognition for classification of protectors (QVGV2) under the UL standard for safety 497B and file #E116110 for 1.5KE6.8A, CA thru 1.5KE250A, CA.

Devices listed in bold, italic are Motorola preferred devices.

5



# TVS

## Axial Leaded for Through-hole Designs (continued)

Table 4. Peak Power Dissipation<sup>(5)</sup> (1500 Watts @ 1 ms Surge – Figure 1)  
Case 41A – Mosorb (continued)

ELECTRICAL CHARACTERISTICS (T <sub>A</sub> = 25°C unless otherwise noted) V <sub>F</sub> = 3.5 V Max, I <sub>F</sub> = 100 A Pulse							
Breakdown Voltage <sup>(6)</sup>		JEDEC Device	Device <sup>(10,11)</sup>	Working Peak Reverse Voltage V <sub>RWM</sub> (Volts)	Maximum Reverse Leakage @ V <sub>RWM</sub> I <sub>R</sub> (μA)	Maximum Reverse Surge Current Figure 1 I <sub>RSM</sub> (Amps)	Maximum Reverse Voltage @ I <sub>RSM</sub> (Clamping Voltage) V <sub>RSM</sub> (Volts)
V <sub>BR</sub> Volts	@ I <sub>T</sub> Pulse (mA)						
Nom							
150	1	1N6299A	1.5KE150A	128	5	7.2	207
160	1	1N6300A	1.5KE160A	136	5	6.8	219
170	1	1N6301A	1.5KE170A	145	5	6.4	234
180	1	1N6302A	1.5KE180A	154	5	6.1	246
200	1	1N6303A	1.5KE200A	171	5	5.5	274
220	1		1.5KE220A	185	5	4.6	328
250	1		1.5KE250A	214	5	5	344

(5) Steady state power dissipation = 5 watts max rating.

(6) Breakdown voltage tolerance is ±5% for A suffix.

(10) For bidirectional types use CA suffix. Have cathode polarity band on each end. (Consult factory for availability).

1N6267–6303A series do not have CA option since the CA is not included in EIA Registration.

(11) UL recognition for classification of protectors (QVGV2) under the UL standard for safety 497B and file #E116110 for 1.5KE6.8A, CA thru 1.5KE250A, CA.

5

# Surface Mount Packages

**Table 5. Peak Power Dissipation (40 Watts @ 1 ms Surge – Figure 1)(28)**

Case 318-07 — Common Cathode

MMBZ15VDLT(12) — SOT-23 Dual Monolithic Common Cathode Bipolar Zener (for ESD protection)

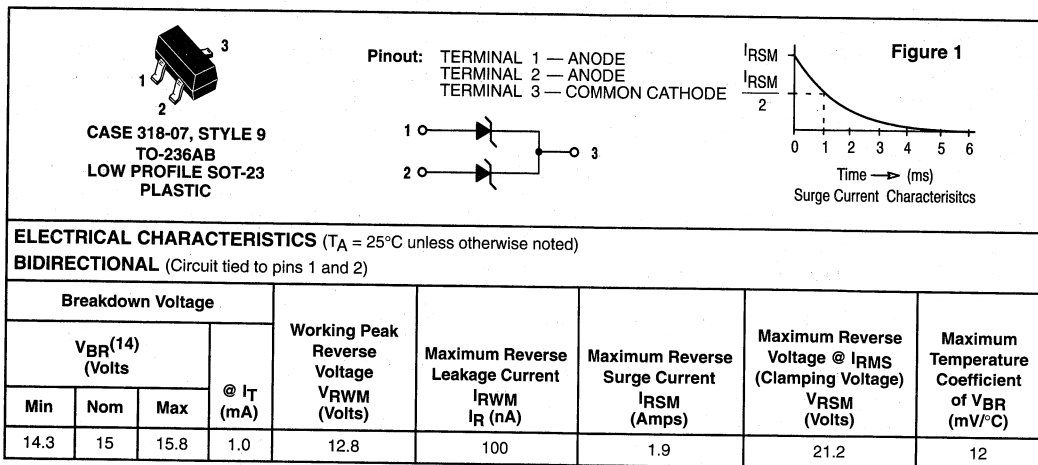

**Table 6. Peak Power Dissipation (24 Watts @ 1 ms Surge – Figure 1)(28)**

Case 318-07 — Common Anode

MMBZ5V6ALT(12) — SOT-23 Dual Monolithic Common Anode Zener (for ESD Protection)

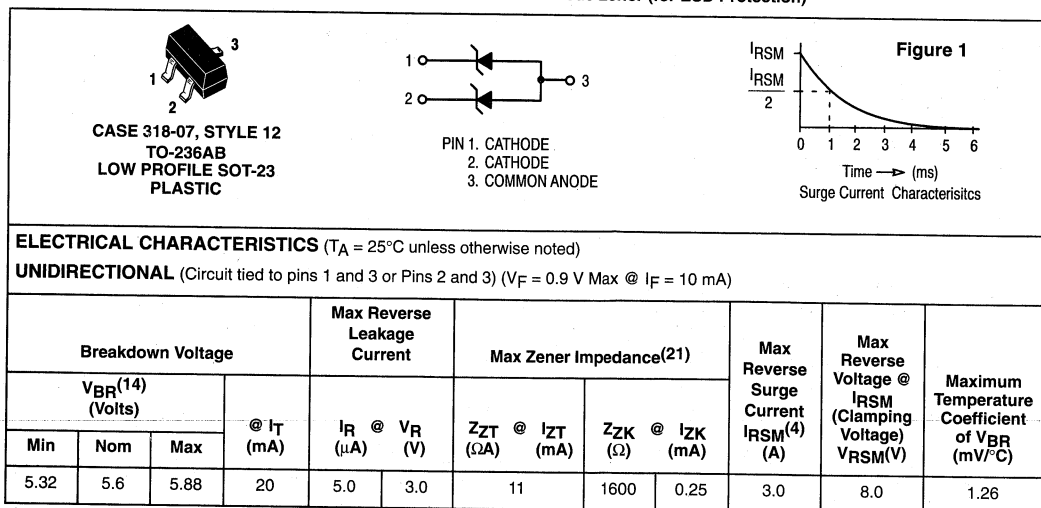

(12) T1 suffix designates tape and reel of 3000 units.

(14)  $V_{BR}$  measured at pulse test current  $I_T$  at an ambient temperature of 25°C.

(21)  $Z_{ZT}$  and  $Z_{ZK}$  are measured by dividing the AC voltage drop across the device by the AC current supplied.

The specified limits are  $I_Z(AC) = 0.1 I_Z(DC)$ , with AC frequency = 1 kHz.

(28) Other voltages may be available upon request. Contact your Motorola representative.

Devices listed in bold, italic are Motorola preferred devices.

# TVS

## Surface Mount Packages (continued)

Table 7. TVS SA Series Through-hole to SMB Series Surface Mount Packages

Peak Pulse Power Rating at 1 ms		500 W			600 W		
Application		Through-hole			Surface Mount		
Series		SA			1 SMB		
Package		Case 59-04			Case 403A		
Polarity		UNI	BI		UNI	BI	
Reverse Stand-Off Voltage (29) V <sub>R</sub> Volts	Maximum Clamping Voltage @ I <sub>pp</sub> V <sub>C</sub> Volts	Part Number	Part Number	Maximum Peak Pulse Current I <sub>pp</sub> Amps	Part Number	Part Number	Maximum Peak Pulse Current I <sub>pp</sub> Amps
5	9.2	<b>SA5.0A</b>		54.3	<b>1SMB5.0AT3</b>		65.2
6	10.3	<b>SA6.0A</b>	SA6.0CA	48.5	<b>1SMB6.0AT3</b>		58.3
6.5	11.2	SA6.5A	SA6.5CA	44.7	1SMB6.5AT3		53.6
7	12	SA7.0A	SA7.0CA	41.7	1SMB7.0AT3		50.0
7.5	12.9	SA7.5A	<b>SA7.5CA</b>	38.8	1SMB7.5AT3		46.5
8	13.6	SA8.0A	SA8.0CA	36.7	1SMB8.0AT3		44.1
8.5	14.4	SA8.5A	SA8.5CA	34.7	1SMB8.5AT3		41.7
9	15.4	SA9.0A	SA9.0CA	32.5	1SMB9.0AT3		39.0
10	17	SA10A	SA10CA	29.4	1SMB10AT3	1SMB10CAT3	35.3
11	18.2	<b>SA11A</b>	SA11CA	27.4	1SMB11AT3	1SMB11CAT3	33
12	19.2	<b>SA12A</b>	SA12CA	25.1	1SMB12AT3	1SMB12CAT3	30.2
13	21.5	SA13A	<b>SA13CA</b>	23.2	1SMB13AT3	1SMB13CAT3	27.9
14	23.2	SA14A	SA14CA	21.5	1SMB14AT3	1SMB14CAT3	25.8
15	24.4	<b>SA15A</b>	<b>SA15CA</b>	20.6	1SMB15AT3	<b>1SMB15CAT3</b>	24
16	26	SA16A	SA16CA	19.2	1SMB16AT3	1SMB16CAT3	23.1
17	27.6	SA17A	SA17CA	18.1	1SMB17AT3	1SMB17CAT3	21.7
18	29.2	SA18A	<b>SA18CA</b>	17.2	1SMB18AT3	1SMB18CAT3	20.5
20	32.4	SA20A	SA20CA	15.4	1SMB20AT3	1SMB20CAT3	18.5
22	35.5	SA22A	SA22CA	14.1	<b>1SMB22AT3</b>	1SMB22CAT3	16.9
24	38.9	SA24A	SA24CA	12.8	1SMB24AT3	1SMB24CAT3	15.4
26	42.1	SA26A	SA26CA	11.9	1SMB26AT3	1SMB26CAT3	14.2
28	45.4	SA28A	SA28CA	11	1SMB28AT3	1SMB28CAT3	13.2
30	48.4	SA30A	SA30CA	10.3	1SMB30AT3	1SMB30CAT3	12.4
33	53.3	SA33A	SA33CA	9.4	1SMB33AT3	1SMB33CAT3	11.3
36	58.1	SA36A	SA36CA	8.6	1SMB36AT3	1SMB36CAT3	10.3
40	64.5	SA40A	SA40CA	7.8	1SMB40AT3	1SMB40CAT3	9.3
43	69.4	SA43A	SA43CA	7.2	1SMB43AT3	1SMB43CAT3	8.6
45	72.7	SA45A	SA45CA	6.9	1SMB45AT3	1SMB45CAT3	8.3
48	77.4	SA48A	SA48CA	6.5	1SMB48AT3	1SMB48CAT3	7.7
51	82.4	SA51A	SA51CA	6.1	1SMB51AT3	1SMB51CAT3	7.3
54	87.1	SA54A	SA54CA	5.7	1SMB54AT3	1SMB54CAT3	6.9
58	93.6	SA58A	SA58CA	5.3	<b>1SMB58AT3</b>	1SMB58CAT3	6.4
60	96.8	SA60A	SA60CA	5.2	1SMB60AT3	1SMB60CAT3	6.2
64	103	SA64A	SA64CA	4.9	1SMB64AT3	1SMB64CAT3	5.8
70	113	SA70A	SA70CA	4.4	1SMB70AT3	1SMB70CAT3	5.3
75	121	SA75A	SA75CA	4.1	1SMB75AT3	1SMB75CAT3	4.9

(29) A transient suppressor is normally selected according to the reverse "Stand Off Voltage" (V<sub>R</sub>) which should be equal to or greater than the DC or continuous peak operating voltage level.

Devices listed in bold, italic are Motorola preferred devices.

5

# TVS

## Surface Mount Packages (continued)

Table 8. TVS SA Series Through-hole to SMB Series Surface Mount Packages (continued)

Peak Pulse Power Rating at 1 ms		500 W			600 W		
Application		Through-hole			Surface Mount		
Series		SA			1 SMB		
Package		Case 59-04			Case 403A		
Polarity		UNI	BI		UNI	BI	
Reverse Stand-Off Voltage (29) V <sub>R</sub> Volts	Maximum Clamping Voltage @ I <sub>pp</sub> V <sub>C</sub> Volts	Part Number	Part Number	Maximum Peak Pulse Current I <sub>pp</sub> Amps	Part Number	Part Number	Maximum Peak Pulse Current I <sub>pp</sub> Amps
78	126	SA78A	SA78CA	4.0	1SMB78AT3	1SMB78CAT3	4.7
85	137	SA85A	SA85CA	3.6	1SMB85AT3		4.4
90	146	SA90A	SA90CA	3.4	1SMB90AT3		4.1
100	162	SA100A	SA100CA	3.1	1SMB100AT3		3.7
110	177	SA110A	SA110CA	2.8	1SMB110AT3		3.4
120	193	SA120A	SA120CA	2	1SMB120AT3		3.1
130	209	SA130A	SA130CA	2.4	1SMB130AT3		2.9
150	243	SA150A	SA150CA	2.1	1SMB150AT3		2.5
160	259	SA160A	SA160CA	1.9	1SMB160AT3		2.3
170	275	SA170A	SA170CA	1.8	1SMB170AT3		2.2

(29) A transient suppressor is normally selected according to the reverse "Stand Off Voltage" (V<sub>R</sub>) which should be equal to or greater than the DC or continuous peak operating voltage level.

5

# TVS Surface Mount Packages (continued)

Table 9. TVS P6KE Series Through-hole to P6SMB Series Surface Mount Packages

Peak Pulse Power Rating at 1 ms		600 W			600 W		
Application		Through-hole			Surface Mount		
Series		P6KE			P6SMB		
Package		Case 17			Case 403A		
Polarity		UNI	BI		UNI	BI	
Reverse Stand-Off Voltage (29) V <sub>R</sub> Volts	Maximum Clamping Voltage @ I <sub>pp</sub> V <sub>C</sub> Volts	Part Number	Part Number	Maximum Peak Pulse Current I <sub>pp</sub> Amps	Part Number	Part Number	Maximum Peak Pulse Current I <sub>pp</sub> Amps
5.8	10.5	<b>P6KE6.8A</b>	P6KE6.8CA	57	<b>P6SMB6.8AT3</b>		57
6.4	11.3	P6KE7.5A	P6KE7.5CA	53	<b>P6SMB7.5AT3</b>		53
7.02	12.1	P6KE8.2A	P6KE8.2CA	50	P6SMB8.2AT3		50
7.78	13.4	P6KE9.1A	P6KE9.1CA	45	P6SMB9.1AT3		45
8.55	14.5	P6KE10A	P6KE10CA	41	<b>P6SMB10AT3</b>		41
9.4	15.6	P6KE11A	P6KE11CA	38	P6SMB11AT3	P6SMB11CAT3	38
10.2	16.7	P6KE12A	P6KE12CA	36	P6SMB12AT3	P6SMB12CAT3	36
11.1	18.2	P6KE13A	P6KE13CA	33	<b>P6SMB13AT3</b>	P6SMB13CAT3	33
12.8	21.2	<b>P6KE15A</b>	P6KE15CA	28	<b>P6SMB15AT3</b>	<b>P6SMB15CAT3</b>	28
13.6	22.5	P6KE16A	P6KE16CA	27	<b>P6SMB16AT3</b>	P6SMB16CAT3	27
15.3	25.2	P6KE18A	P6KE18CA		<b>P6SMB18AT3</b>	P6SMB18CAT3	
17.1	27.7	P6KE20A	P6KE20CA	22	<b>P6SMB20AT3</b>	P6SMB20CAT3	22
18.8	30.6	P6KE22A	P6KE22CA	20	<b>P6SMB22AT3</b>	P6SMB22CAT3	20
20.5	33.2	P6KE24A	P6KE24CA	18	P6SMB24AT3	P6SMB24CAT3	18
23.1	37.7	P6KE27A	P6KE27CA	16	<b>P6SMB27AT3</b>	P6SMB27CAT3	16
25.6	41.4	P6KE30A	P6KE30CA	14.4	<b>P6SMB30AT3</b>	P6SMB30CAT3	14.4
28.2	45.7	P6KE33A	P6KE33CA	13.2	<b>P6SMB33AT3</b>	P6SMB33CAT3	13.2
30.8	49.9	P6KE36A	P6KE36CA	12	<b>P6SMB36AT3</b>	P6SMB36CAT3	12
33.3	53.9	P6KE39A	P6KE39CA	11.2	<b>P6SMB39AT3</b>	P6SMB39CAT3	11.2
36.8	59.3	P6KE43A	P6KE43CA	10.1	P6SMB43AT3	P6SMB43CAT3	10.1
40.2	64.8	P6KE47A	P6KE47CA	9.3	P6SMB47AT3	P6SMB47CAT3	9.3
43.6	70.1	P6KE51A	P6KE51CA	8.6	<b>P6SMB51AT3</b>	P6SMB51CAT3	8.6
47.8	77	P6KE56A	P6KE56CA	7.8	P6SMB56AT3	P6SMB56CAT3	7.8
53	85	P6KE62A	P6KE62CA	7.1	P6SMB62AT3	P6SMB62CAT3	7.1
58.1	92	P6KE68A	P6KE68CA	6.5	P6SMB68AT3	P6SMB68CAT3	6.5
64.1	103	P6KE75A	P6KE75CA	5.8	P6SMB75AT3	P6SMB75CAT3	5.8
70.1	113	P6KE82A	P6KE82CA	5.3	P6SMB82AT3	P6SMB82CAT3	5.3
77.8	125	P6KE91A	P6KE91CA	4.8	P6SMB91AT3	P6SMB91CAT3	4.8
85.5	137	P6KE100A	P6KE100CA	4.4	P6SMB100AT3		4.4
94	152	P6KE110A	P6KE110CA	4	P6SMB110AT3		4
102	165	P6KE120A	P6KE120CA	3.6	P6SMB120AT3		3.6
111	179	P6KE130A	P6KE130CA	3.3	P6SMB130AT3		3.3
128	207	P6KE150A	P6KE150CA	2.9	P6SMB150AT3		2.9
136	219	P6KE160A	P6KE160CA	2.7	P6SMB160AT3		2.7
145	234	P6KE170A	P6KE170CA	2.6	P6SMB170AT3		2.6
154	246	P6KE180A	P6KE180CA	2.4	P6SMB180AT3		2.4
171	274	P6KE200A	P6KE200CA	2.2	P6SMB200AT3		2.2

(29) A transient suppressor is normally selected according to the reverse "Stand Off Voltage" (V<sub>R</sub>) which should be equal to or greater than the DC or continuous peak operating voltage level.

Devices listed in bold, italic are Motorola preferred devices.

5

# TVS

## Surface Mount Packages (continued)

Table 10. TVS 1N6267A and 1.5KE Series Through-hole to 1.5SMC Series Surface Mount Packages

Peak Pulse Power Rating at 1 ms		1500 W				
Application		Through-hole			Surface Mount	
Series		1N6267A	1.5KE		1.5SMC	
Package		Case 41A			Case 403A	
Polarity		UNI		BI	UNI	
Reverse Stand-Off Voltage (29) V <sub>R</sub> Volts	Maximum Clamping Voltage @ I <sub>pp</sub> V <sub>C</sub> Volts	JEDEC Part Number	Part Number	Part Number	Part Number	Maximum Peak Pulse Current I <sub>pp</sub> Amps
5.8	10.5	<b>1N6267A</b>	1.5KE6.8A <sup>(31)</sup>	1.5KE6.8CA	1.5SMC6.8AT3	143
6.4	11.3	1N6268A	1.5KE7.5A	1.5KE7.5CA	1.5SMC7.5AT3	132
7.02	12.1	1N6269A	1.5KE8.2A	1.5KE8.2CA	1.5SMC8.2AT3	124
7.78	13.4	1N6270A	1.5KE9.1A	1.5KE9.1CA	1.5SMC9.1AT3	112
8.55	14.5	1N6271A	1.5KE10A	1.5KE10CA	1.5SMC10AT3	103
9.4	15.6	1N6272A	1.5KE11A	1.5KE11CA	1.5SMC11AT3	96
10.2	16.7	1N6273A	1.5KE12A	1.5KE12CA	1.5SMC12AT3	90
11.1	18.2	1N6274A	1.5KE13A	1.5KE13CA	1.5SMC13AT3	82
12.8	21.2	<b>1N6275A</b>	1.5KE15A	1.5KE15CA	<b>1.5SMC15AT3</b>	71
13.6	22.5	1N6276A	1.5KE16A	1.5KE16CA	1.5SMC16AT3	67
15.3	25.2	1N6277A	1.5KE18A	1.5KE18CA	1.5SMC18AT3	59.5
17.1	27.7	1N6278A	1.5KE20A	1.5KE20CA	1.5SMC20AT3	54
18.8	30.6	1N6279A	<b>1.5KE22A</b>	1.5KE22CA	1.5SMC22AT3	49
20.5	33.2	<b>1N6280A</b>	1.5KE24A	1.5KE24CA	<b>1.5SMC24AT3</b>	45
23.1	37.7	<b>1N6281A</b>	1.5KE27A	1.5KE27CA	1.5SMC27AT3	40
25.6	41.4	<b>1N6282A</b>	1.5KE30A	1.5KE30CA	1.5SMC30AT3	36
28.2		<b>1N6283A</b>	1.5KE33A	1.5KE33CA	1.5SMC33AT3	33
30.8	49.9	1N6284A	1.5KE36A	<b>1.5KE36CA</b>	<b>1.5SMC36AT3</b>	30
33.3	53.9	<b>1N6285A</b>	<b>1.5KE39A</b>	1.5KE39CA	<b>1.5SMC39AT3</b>	28
36.8	59.3	1N6286A	1.5KE43A	1.5KE43CA	<b>1.5SMC43AT3</b>	25.3
40.2	64.8	1N6287A	1.5KE47A	1.5KE47CA	<b>1.5SMC47AT3</b>	23.2
43.6	70.1	<b>1N6288A</b>	1.5KE51A	1.5KE51CA	1.5SMC51AT3	21.4
47.8	77	1N6289A	<b>1.5KE56A</b>	1.5KE56CA	1.5SMC56AT3	19.5
53	85	1N6290A	1.5KE62A	1.5KE62CA	1.5SMC62AT3	17.7
58.1	92	1N6291A	1.5KE68A	1.5KE68CA	1.5SMC68AT3	16.3
64.1	103	1N6292A	1.5KE75A	1.5KE75CA	<b>1.5SMC75AT3</b>	14.6
70.1	113	1N6293A	1.5KE82A	1.5KE82CA	1.5SMC82AT3	13.3
77.8	125	1N6294A	1.5KE91A	1.5KE91CA	1.5SMC91AT3	12
85.5	137	1N6295A	1.5KE100A	1.5KE100CA		11
94	152	1N6296A	1.5KE110A	1.5KE110CA		9.9
102	165	1N6297A	1.5KE120A	1.5KE120CA		9.1
111	179	1N6298A	1.5KE130A	1.5KE130CA		8.4
128	207	1N6299A	1.5KE150A	1.5KE150CA		7.2
136	219	1N6300A	1.5KE160A	1.5KE160CA		6.8
145	234	1N6301A	1.5KE170A	1.5KE170CA		6.4
154	246	1N6302A	1.5KE180A	1.5KE180CA		6.1
171	274	1N6303A	1.5KE200A	1.5KE200CA		5.5

5

(29) A transient suppressor is normally selected according to the reverse "Stand Off Voltage" (V<sub>R</sub>) which should be equal to or greater than the DC or continuous peak operating voltage level.

(31) Not available as bidirectional.

Devices listed in bold, italic are Motorola preferred devices.

# TVS

## Surface Mount Packages (continued)

Table 11. TVS 1SMC Surface Mount Packages

Peak Pulse Power Rating at 1 ms		1500 W	
Application		Surface Mount	
Series		1SMC	
Package		Case 403A	
Polarity		UNI	
Reverse Stand-Off Voltage $V_R$ Volts	Maximum Clamping Voltage @ $I_{pp}$ $V_C$ Volts	Part Number	Maximum Peak Pulse Current $I_{pp}$ Amps
5	9.2	1SMC5.0AT3	163
6	10.3	1SMC6.0AT3	145.6
6.5	11.2	1SMC6.5AT3	133.9
7	12	1SMC7.0AT3	125
7.5	12.9	1SMC7.5AT3	116.3
8	13.6	1SMC8.0AT3	110.3
8.5	14.4	1SMC8.5AT3	104.2
9	15.4	1SMC9.0AT3	97.4
10	17	1SMC10AT3	88.2
11	18.2	1SMC11AT3	82.4
12	19.9	1SMC12AT3	75.3
13	21.5	1SMC13AT3	69.7
14	23.2	1SMC14AT3	64.7
15	24.4	1SMC15AT3	61.5
16	26	1SMC16AT3	57.7
17	27.6	1SMC17AT3	53.3
18	29.2	1SMC18AT3	51.4
20	32.4	1SMC20AT3	46.3
22	35.5	1SMC22AT3	42.2
24	38.9	<b>1SMC24AT3</b>	38.6
26	42.1	1SMC26AT3	35.6
28	45.4	1SMC28AT3	33
30	48.4	1SMC30AT3	31
33	53.3	1SMC33AT3	28.1
36	58.1	1SMC36AT3	25.8
40	64.5	1SMC40AT3	23.2
43	69.4	1SMC43AT3	21.6
45	72.7	1SMC45AT3	20.6
48	77.4	1SMC48AT3	19.4
51	82.4	1SMC51AT3	18.2
54	87.1	1SMC54AT3	17.2
58	93.6	<b>1SMC58AT3</b>	16
60	96.8	1SMC60AT3	15.5
64	103	1SMC64AT3	14.6
70	113	1SMC70AT3	13.3
75	121	1SMC75AT3	12.4
78	126	1SMC78AT3	11.4

5

Devices listed in bold, italic are Motorola preferred devices.

# TVS

## Overvoltage Transient Suppressors

Table 12. Overvoltage Transient Suppressors

Overvoltage transient suppressors are designed for protection against over-voltage conditions in the auto electrical system including the "LOAD DUMP" phenomenon that occurs when the battery open circuits while the car is running.

OVERVOLTAGE TRANSIENT SUPPRESSOR	
	<b>CASE 194-04</b> <b>MR2535L</b>
<b>V<sub>RRM</sub> (Volts)</b>	20
<b>I<sub>O</sub> (Amp)</b>	35
<b>V<sub>(BR)</sub> (Volts)</b>	24-32
<b>I<sub>RSM</sub><sup>(30)</sup> (Amp)</b>	110
<b>T<sub>C</sub> @ Rated I<sub>O</sub> (°C)</b>	150
<b>T (°C)</b>	175

<sup>(30)</sup> Time constant = 10 ms, duty cycle ≤ 1%, T<sub>C</sub> = 25°C.  
Note: MR2535L is considered part of the rectifier product portfolio.

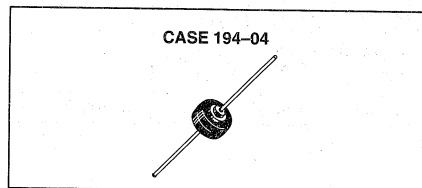

Devices listed in bold, italic are Motorola preferred devices.



# Zener Diodes

## Voltage Regulator Diodes

Table 13. Axial Leaded for Through-hole Designs – 500 mW

Nominal Zener Breakdown Voltage	500 mW Cathode = Polarity Band	500 mW Low Level Cathode = Polarity Band	500 mW Cathode = Polarity Band						500 mW Low Level Cathode = Polarity Band	500 mW Cathode = Polarity Band		
			(*Note 4)	(*Note 5)	(*Note 6)	(*Note 7)	(*Note 8)	(*Note 9)		(*Note 10)	(*Note 8)	
Volts			 <p>Glass Case 299 DO-204AH (DO-35)</p>									
1.8		1N4678								MZ4614		
2.0		1N4679								MZ4615		
2.2		1N4680								MZ4616		
2.4	1N4370A	1N4681	1N5221B	1N5985B	BZX55C2V4RL	BZX79C2V4RL				MZ4617		
2.5			1N5222B									
2.7	1N4371A	1N4682	1N5223B	1N5986B	BZX55C2V7RL	BZX79C2V7RL	BZX83C2V7RL			MZ4618		ZPD2.7RL
2.8			1N5224B									
3.0	1N4372A	1N4683	1N5225B	1N5987B	BZX55C3V0RL	BZX79C3V0RL	BZX83C3V0RL			MZ4619		ZPD3.0RL
3.3	<b>1N746A</b>	1N4684	<b>1N5226B</b>	1N5988B	BZX55C3V3RL	BZX79C3V3RL	BZX83C3V3RL			MZ4620		ZPD3.3RL
3.6	1N747A	1N4685	1N5227B	1N5989B	BZX55C3V6RL	BZX79C3V6RL	BZX83C3V6RL			MZ4621		
3.9	1N748A	1N4686	<b>1N5228B</b>	1N5990B	BZX55C3V9RL	BZX79C3V9RL	BZX83C3V9RL			MZ4622	MZ5520B	ZPD3.6RL
4.3	1N749A	1N4687	1N5229B	1N5991B	BZX55C4V3RL	BZX79C4V3RL	BZX83C4V3RL			MZ4623	MZ5521B	ZPD4.3RL
4.7	1N750A	<b>1N4688</b>	1N5230B	1N5992B	BZX55C4V7RL	BZX79C4V7RL	BZX83C4V7RL			MZ4624	MZ5522B	ZPD4.7RL
5.1	<b>1N751A</b>	1N4689	<b>1N5231B</b>	<b>1N5993B</b>	BZX55C5V1RL	BZX79C5V1RL	BZX83C5V1RL			MZ4625	MZ5523B	ZPD5.1RL
5.6	<b>1N752A</b>	1N4690	<b>1N5232B</b>	<b>1N5994B</b>	BZX55C5V6RL	BZX79C5V6RL	BZX83C5V6RL			MZ4626	MZ5524B	ZPD5.6RL
6.0			1N5233B									
6.2	<b>1N753A</b>	1N4691	<b>1N5234B</b>	1N5995B	BZX55C6V2RL	BZX79C6V2RL	BZX83C6V2RL			MZ4627	MZ5525B	ZPD6.2RL
6.8	1N754A 1N957B	1N4692	<b>1N5235B</b>	1N5996B	BZX55C6V8RL	BZX79C6V8RL	BZX83C6V8RL			MZ4099	MZ5526B	ZPD6.8RL
7.5	1N755A 1N958B	1N4693	1N5236B	1N5997B	BZX55C7V5RL	BZX79C7V5RL	BZX83C7V5RL			MZ4100	MZ5527B	ZPD7.5RL
8.2	1N756A 1N959B	1N4694	<b>1N5237B</b>	<b>1N5998B</b>	BZX55C8V2RL	BZX79C8V2RL	BZX83C8V2RL			MZ4101	MZ5528B	ZPD8.2RL
8.7		1N4695	1N5238B							MZ4102		
9.1	1N757A 1N960B	1N4696	1N5239B	1N5999B	BZX55C9V1RL	BZX79C9V1RL	BZX83C9V1RL			MZ4103	MZ5529B	ZPD9.1RL
10	1N758A 1N961B	1N4697	<b>1N5240B</b>	1N6000B	BZX55C10RL	BZX79C10RL	BZX83C10RL			MZ4104	MZ5530B	ZPD10RL
11	1N962B	1N4698	1N5241B	1N6001B	BZX55C11RL	BZX79C11RL	BZX83C11RL					ZPD11RL
12	1N759A 1N963B	1N4699	<b>1N5242B</b>	1N6002B	BZX55C12RL	BZX79C12RL	BZX83C12RL					ZPD12RL
13	1N964B	1N4700	1N5243B	1N6003B	BZX55C13RL	BZX79C13RL	BZX83C13RL					ZPD13RL
14		1N4701	1N5244B									
15	1N965B	1N4702	<b>1N5245B</b>	1N6004B	BZX55C15RL	BZX79C15RL	BZX83C15RL					ZPD15RL
16	1N966B	1N4703	<b>1N5246B</b>	1N6005B	BZX55C16RL	BZX79C16RL	BZX83C16RL					ZPD16RL
17		1N4704	1N5247B									
18	1N967B	1N4705	1N5248B	1N6006B	BZX55C18RL	BZX79C18RL	BZX83C18RL					ZPD18RL

\*See Notes on page 5.2-20.

Devices listed in bold, italic are Motorola preferred devices.

# Zener Diodes

## Voltage Regulator Diodes (continued)

Table 13. Axial Leaded for Through-hole Designs – 500 mW (continued)

Nominal Zener Breakdown Voltage	500 mW Cathode = Polarity Band	500 mW Low Level Cathode = Polarity Band	500 mW Cathode = Polarity Band					500 mW Low Level Cathode = Polarity Band	500 mW Cathode = Polarity Band										
			(*Note 4)	(*Note 5)	(*Note 6)	(*Note 7)	(*Note 8)		(*Note 9)	(*Note 10)	(*Note 8)								
Volts			 <p>Glass Case 299 DO-204AH (DO-35)</p>																
19		1N4706	1N5249B																
20	1N968B	1N4707	<b>1N5250B</b>	1N6007B	BZX55C20RL	BZX79C20RL	BZX83C20RL												ZPD20RL
22	1N969B	1N4708	1N5251B	1N6008B	BZX55C22RL	BZX79C22RL	BZX83C22RL												ZPD22RL
24	1N970B	1N4709	1N5252B	1N6009B	BZX55C24RL	BZX79C24RL	BZX83C24RL												ZPD24RL
25		1N4710	1N5253B																
27	1N971B	1N4711	1N5254B	1N6010B	BZX55C27RL	BZX79C27RL	BZX83C27RL												ZPD27RL
28		1N4712	1N5255B																
30	1N972B	1N4713	1N5256B	1N6011B	BZX55C30RL	BZX79C30RL	BZX83C30RL												ZPD30RL
33	1N973B	1N4714	1N5257B	1N6012B	BZX55C33RL	BZX79C33RL	BZX83C33RL												ZPD33RL
36	1N974B	1N4715	1N5258B	1N6013B	BZX55C36RL	BZX79C36RL													
39	1N975B	1N4716	1N5259B	1N6014B	BZX55C39RL	BZX79C39RL													
43	1N976B	1N4717	1N5260B	1N6015B	BZX55C43RL	BZX79C43RL													
47	1N977B		1N5261B	1N6016B	BZX55C47RL	BZX79C47RL													
51	1N978B		1N5262B	1N6017B	BZX55C51RL	BZX79C51RL													
56	1N979B		1N5263B	1N6018B	BZX55C56RL	BZX79C56RL													
60			1N5264B																
62	1N980B		1N5265B	1N6019B	BZX55C62RL	BZX79C62RL													
68	1N981B		1N5266B	1N6020B	BZX55C68RL	BZX79C68RL													
75	1N982B		1N5267B	1N6021B	BZX55C75RL	BZX79C75RL													
82	1N983B		1N5268B	1N6022B	BZX55C82RL	BZX79C82RL													
87			1N5269B																
91	1N984B		1N5270B	1N6023B	BZX55C91RL	BZX79C91RL													
100	1N985B		1N5271B	1N6024B		BZX79C100RL													
110	1N986B		1N5272B	1N6025B		BZX79C110RL													
120	1N987B		1N5273B			BZX79C120RL													
130	1N988B		1N5274B			BZX79C130RL													
140			1N5275B																
150	1N989B		1N5276B			BZX79C150RL													
160	1N990B		1N5277B			BZX79C160RL													
170			1N5278B																
180	1N991B		1N5279B			BZX79C180RL													
190			1N5280B																
200	1N992B		1N5281B			BZX79C200RL													
240																			
270																			
300																			
330																			
360																			
400																			





\*See Notes on page 5.2-20.

Devices listed in bold, italic are Motorola preferred devices.

# Zener Diodes

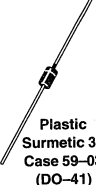
## Voltage Regulator Diodes (continued)

Table 14. Axial Leaded for Through-hole Designs – 1, 1.3, 1.5, 3 and 5 Watt

Nominal Zener Breakdown Voltage	1 Watt		1.3 Watt			1.5 Watt	3 Watt	5 Watt
	Cathode = Polarity Band		Cathode = Polarity Band			Cathode = Polarity Band	Cathode = Polarity Band	Cathode = Polarity Band
(*Note 1)	(*Note 11)	(*Note 12)	(*Note 13)	(*Note 14)	(*Note 15)	(*Note 16)	(*Note 17)	(*Note 18)
Volts								
3.3	1N4728A	MZP4728A	BZX85C3V3RL			1N5913B		1N5333B
3.6	1N4729A	MZP4729A	<b>BZX85C3V6RL</b>			1N5914B		1N5334B
3.9	1N4730A	MZP4730A	BZX85C3V9RL	MZPY3.9RL	MZD3.9RL	1N5915B	3EZ3.9D5	1N5335B
4.3	1N4731A	MZP4731A	BZX85C4V3RL	MZPY4.3RL	MZD4.3RL	1N5916B	<b>3EZ4.3D5</b>	1N5336B
4.7	1N4732A	MZP4732A	BZX85C4V7RL	MZPY4.7RL	MZD4.7RL	1N5917B	3EZ4.7D5	1N5337B
5.1	<b>1N4733A</b>	MZP4733A	BZX85C5V1RL	MZPY5.1RL	MZD5.1RL	<b>1N5918B</b>	3EZ5.1D5	1N5338B
5.6	<b>1N4734A</b>	MZP4734A	BZX85C5V6RL	MZPY5.6RL	MZD5.6RL	1N5919B	3EZ5.6D5	1N5339B
6.0								1N5340B
6.2	<b>1N4735A</b>	MZP4735A	BZX85C6V2RL	MZPY6.2RL	MZD6.2RL	<b>1N5920B</b>	3EZ6.2D5	1N5341B
6.8	<b>1N4736A</b>	MZP4736A	BZX85C6V8RL	MZPY6.8RL	MZD6.8RL	1N5921B	3EZ6.8D5	1N5342B
7.5	1N4737A	MZP4737A	BZX85C7V5RL	MZPY7.5RL	MZD7.5RL	1N5922B	3EZ7.5D5	1N5343B
8.2	<b>1N4738A</b>	MZP4738A	BZX85C8V2RL	MZPY8.2RL	MZD8.2RL	1N5923B	3EZ8.2D5	1N5344B
8.7								1N5345B
9.1	1N4739A	MZP4739A	BZX85C9V1RL	MZPY9.1RL	MZD9.1RL	1N5924B	3EZ9.1D5	1N5346B
10	<b>1N4740A</b>	MZP4740A	BZX85C10RL	MZPY10RL	MZD10RL	1N5925B	3EZ10D5	1N5347B
11	<b>1N4741A</b>	MZP4741A	BZX85C11RL	MZPY11RL	MZD11RL	1N5926B	3EZ11D5	1N5348B
12	<b>1N4742A</b>	MZP4742A	BZX85C12RL	MZPY12RL	MZD12RL	1N5927B	3EZ12D5	1N5349B
13	1N4743A	MZP4743A	BZX85C13RL	MZPY13RL	MZD13RL	1N5928B	3EZ13D5	1N5350B
14							3EZ14D5	1N5351B
15	<b>1N4744A</b>	MZP4744A	BZX85C15RL	MZPY15RL	MZD15RL	<b>1N5929B</b>	3EZ15D5	1N5352B
16	<b>1N4745A</b>	MZP4745A	BZX85C16RL	MZPY16RL	MZD16RL	1N5930B	3EZ16D5	1N5353B
17							3EZ17D5	1N5354B
18	<b>1N4746A</b>	<b>MZP4746A</b>	BZX85C18RL	MZPY18RL	<b>MZD18RL</b>	1N5931B	3EZ18D5	1N5355B
19							3EZ19D5	1N5356B
20	<b>1N4747A</b>	MZP4747A	BZX85C20RL	MZPY20RL	MZD20RL	1N5932B	3EZ20D5	1N5357B
22	<b>1N4748A</b>	MZP4748A	<b>BZX85C22RL</b>	MZPY22RL	MZD22RL	1N5933B	3EZ22D5	1N5358B
24	<b>1N4749A</b>	<b>MZP4749A</b>	<b>BZX85C24RL</b>	MZPY24RL	MZD24RL	1N5934B	3EZ24D5	1N5359B
25							3EZ25D5	1N5360B
27	<b>1N4750A</b>	MZP4750A	BZX85C27RL	MZPY27RL	MZD27RL	1N5935B	3EZ27D5	1N5361B
28							3EZ28D5	1N5362B
30	<b>1N4751A</b>	<b>MZP4751A</b>	BZX85C30RL	MZPY30RL	MZD30RL	<b>1N5936B</b>	3EZ30D5	1N5363B
33	<b>1N4752A</b>	MZP4752A	BZX85C33RL	MZPY33RL	MZD33RL	1N5937B	3EZ33D5	1N5364B
36	1N4753A	MZP4753A	BZX85C36RL	MZPY36RL	MZD36RL	1N5938B	3EZ36D5	1N5365B
39	1N4754A	MZP4754A	BZX85C39RL	MZPY39RL	MZD39RL	1N5939B	3EZ39D5	1N5366B
43	1N4755A	MZP4755A	BZX85C43RL	MZPY43RL	MZD43RL	1N5940B	3EZ43D5	1N5367B
47	1N4756A	MZP4756A	BZX85C47RL	MZPY47RL	MZD47RL	1N5941B	3EZ47D5	1N5368B
51	1N4757A	MZP4757A	BZX85C51RL	MZPY51RL	MZD51RL	1N5942B	3EZ51D5	1N5369B
56	1N4758A	MZP4758A	BZX85C56RL	MZPY56RL	MZD56RL	1N5943B	3EZ56D5	1N5370B
60							3EZ60D5	1N5371B
62	1N4759A	MZP4759A	BZX85C62RL	MZPY62RL	MZD62RL	1N5944B	3EZ62D5	1N5372B
68	1N4760A	MZP4760A	BZX85C68RL	MZPY68RL	MZD68RL	1N5945B	3EZ68D5	1N5373B

\*See Notes on page 5.2-20.



Devices listed in bold, italic are Motorola preferred devices.

5

# Zener Diodes

## Voltage Regulator Diodes (continued)

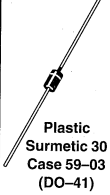
Table 14. Axial Leaded for Through-hole Designs – 1, 1.3, 1.5, 3 and 5 Watt (continued)

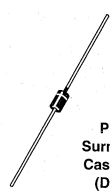
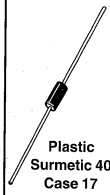
Nominal Zener Breakdown Voltage	1 Watt Cathode = Polarity Band		1.3 Watt Cathode = Polarity Band			1.5 Watt Cathode = Polarity Band	3 Watt Cathode = Polarity Band	5 Watt Cathode = Polarity Band
	(*Note 1)	(*Note 11)	(*Note 12)	(*Note 13)	(*Note 14)	(*Note 15)	(*Note 16)	(*Note 17)
Volts								
75	1N4761A	MZP4761A	BZX85C75RL	MZPY75RL	MZD75	1N5946B	3EZ75D5	1N5374B
82	1N4762A	MZP4762A	BZX85C82RL	MZPY82RL	MZD82	1N5947B	3EZ82D5	1N5375B
87								1N5376B
91	1N4763A	MZP4763A	BZX85C91RL	MZPY91RL	MZD91	1N5948B	3EZ91D5	1N5377B
100	1N4764A	MZP4764A	BZX85C100RL	MZPY100RL	MZD100	1N5949B	3EZ100D5	1N5378B
110		1M110ZS5			MZD110	1N5950B	3EZ110D5	1N5379B
120		1M120ZS5			MZD120	1N5951B	3EZ120D5	1N5380B
130		1M130ZS5			MZD130	1N5952B	3EZ130D5	1N5381B
140							3EZ140D5	1N5382B
150		1M150ZS5			MZD150	1N5953B	3EZ150D5	1N5383B
160		1M160ZS5			MZD160	1N5954B	3EZ160D5	1N5384B
170							3EZ170D5	1N5385B
180		1M180ZS5			MZD180	<b>1N5955B</b>	3EZ180D5	1N5386B
190							3EZ190D5	1N5387B
200		1M200ZS5			MZD200	1N5956B	3EZ200D5	1N5388B
220							3EZ220D5	
240							3EZ240D5	
270							3EZ270D5	
300							3EZ300D5	
330							3EZ330D5	
360							3EZ360D5	
400							3EZ400D5	

\*See Notes on page 5.2-20.

5

Devices listed in bold, italic are Motorola preferred devices.

# Zener Diodes

## Notes — Axial Leaded Chart

1. Zener Voltage is the key parameter for each device type. It is specified at a particular test current applied at either thermal equilibrium (T.E.) or pulse test condition. The voltage tolerance for the device types listed is, in general,  $\pm 5\%$ ; however, for some series, the voltage tolerance varies from device type to device type over a range of  $\pm(5$  to  $8.5)\%$ . Consult the complete data sheet to determine the exact test conditions and minimum/maximum limits for the zener voltage. Consult Application Note AN924 regarding measurement of Zener Voltage (pulse versus thermal equilibrium).

Power Ratings represent the capability of the case size listed as supplied by Motorola. These ratings may be higher than the JEDEC registration and/or the same device types supplied by other manufacturers.

### **$V_Z$ Test Conditions And Tolerances**

2. 1N4370A/1N746A Series

$I_{ZT} = 20$  mA (T.E.).

A suffix =  $\pm 5\%$ .

C suffix =  $\pm 2\%$ .

D suffix =  $\pm 1\%$ .

1N957B Series

$I_{ZT}$  @ approximately 125 mW point (T.E.).

B suffix =  $\pm 5\%$ .

C suffix =  $\pm 2\%$ .

D suffix =  $\pm 1\%$ .

3. 1N4678 Series  $I_{ZT} = 50$   $\mu$ A (T.E.).

No suffix =  $\pm 5\%$ .

C suffix =  $\pm 2\%$ .

D suffix =  $\pm 1\%$ .

Also has delta  $V_Z$  parameter and limit.

4. 1N5221B–42B  $I_{ZT} = 20$  mA (T.E.).

1N5243B–81B  $I_{ZT}$  @ approximately 125 mW point (T.E.).

B suffix =  $\pm 5\%$ .

C suffix =  $\pm 2\%$ .

D suffix =  $\pm 1\%$ .

5. 1N5985B–6013B  $I_{ZT} = 5$  mA (T.E.).

1N6014B–23B  $I_{ZT} = 2$  mA (T.E.).

1N6024B–25B  $I_{ZT} = 1$  mA (T.E.).

B suffix =  $\pm 5\%$ .

C suffix =  $\pm 2\%$ .

D suffix =  $\pm 1\%$ .

6. BZX55C2V4–C36RL  $I_{ZT} = 5$  mA (T.E.).

BZX55C39–C82RL  $I_{ZT} = 2.5$  mA (T.E.).

BZX55C91RL  $I_{ZT} = 1$  mA (T.E.).

C indicates  $\pm(5$  to  $8.5)\%$  depending on type number.

Replace C with B for  $\pm 2\%$ .

7. BZX79C2V4–C24RL  $I_{ZT} = 5$  mA (pulse).

BZX79C27–C91RL  $I_{ZT} = 2$  mA (pulse).

BZX79C100–C200RL  $I_{ZT} = 1$  mA (pulse).

C indicates  $\pm(5$  to  $8.5)\%$  depending on type number.

Replace C with B for  $\pm 2\%$ .

Replace C with A for  $\pm 1\%$ .

8. BZX83C2V7–C33RL  $I_{ZT} = 5$  mA (pulse).

ZPD2.7–33RL  $I_{ZT} = 5$  mA (pulse).

Tolerance is  $\pm(5$  to  $8.5)\%$  depending on type number.

9. MZ4614–27  $I_{ZT} = 250$   $\mu$ A (T.E.).

MZ4099–4104  $I_{ZT} = 250$   $\mu$ A (T.E.).

Tolerance is  $\pm 5\%$ .

10. MZ5520B–21B  $I_{ZT} = 20$  mA (T.E.).

MZ5522B  $I_{ZT} = 10$  mA (T.E.).

MZ5523B  $I_{ZT} = 5$  mA (T.E.).

MZ5524B  $I_{ZT} = 3$  mA (T.E.).

MZ5525B–30B  $I_{ZT} = 1$  mA (T.E.).

Tolerance is  $\pm 5\%$ .

Also has delta  $V_Z$  parameter and limit.

11. 1N4728A–64A

$I_{ZT}$  @ approximately 250 mW point (T.E.).

A suffix =  $\pm 5\%$ .

C suffix =  $\pm 2\%$ .

D suffix =  $\pm 1\%$ .

12. MZP4728A–64A

1M110ZS5–200ZS5

$I_{ZT}$  @ approximately 250 mW point (T.E.).

MZP Series A suffix =  $\pm 5\%$ .

1M Series 5 suffix =  $\pm 5\%$ .

13. BZX85C3V3–C100RL

$I_{ZT}$  varies from 185 mW to 300 mW point depending on type number (pulse).

C indicates  $\pm(5$  to  $8.5)\%$  depending on type number.

Replace C with B for  $\pm 2\%$ .

14. MZPY3.9–8.2RL  $I_{ZT} = 100$  mA (pulse).

MZPY9.1–15RL  $I_{ZT} = 50$  mA (pulse).

MZPY16–33RL  $I_{ZT} = 25$  mA (pulse).

MZPY36–82RL  $I_{ZT} = 10$  mA (pulse).

MZPY91–100RL  $I_{ZT} = 5$  mA (pulse).

No suffix tolerance is approximately  $\pm(5$  to  $8.5)\%$  depending on type number.

C suffix =  $\pm 2\%$ .

D suffix =  $\pm 1\%$ .

15. MZD3.9–8.2  $I_{ZT} = 100$  mA (pulse).

MZD9.1–15  $I_{ZT} = 50$  mA (pulse).

MZD16–33  $I_{ZT} = 25$  mA (pulse).

MZD36–82  $I_{ZT} = 10$  mA (pulse).

MZD91–200  $I_{ZT} = 5$  mA (pulse).

Tolerance is  $\pm(5$  to  $8.5)\%$  depending on type number.

16. 1N5913B–56B

$I_{ZT}$  @ approximately 375 mW point (T.E.).

B suffix =  $\pm 5\%$ .

17. 3EZ3.9D5–400D5

$I_{ZT}$  @ approximately 750 mW point (pulse).

Suffix 5 =  $\pm 5\%$ .

18. 1N5333B–88B

$I_{ZT}$  varies from 0.9 to 1.5 W point depending on type number (pulse)

B suffix =  $\pm 5\%$ .



Also has delta  $V_Z$  parameter and limit.

Devices listed in bold, italic are Motorola preferred devices.

# Zener Diodes

## Voltage Regulator Diodes (continued)

Table 15. Surface Mount Packages

Nominal Zener Breakdown Voltage	225 mW Surface Mount		500 mW Surface Mount	500 mW Low Level Surface Mount	500 mW Surface Mount	3 Watt Surface Mount
	SOT-23		SOD-123	SOD-123	SOD-123	SMB
(*Note 1)	(*Note 2)	(*Note 3)	(*Note 4)	(*Note 5)	(*Note 6)	(*Note 7)
Volts	 Anode <span style="margin-left: 100px;">Cathode</span> No Connection Plastic Case 318-07 TO-236AB		 Plastic Case 425, Style 1		 Plastic Case 403A Cathode = Notch	
1.8				MMSZ4678T1		
2.0				MMSZ4679T1		
2.2				<b>MMSZ4680T1</b>		
2.4	BZX84C2V4LT1	MMBZ5221BLT1	MMSZ2V4T1	MMSZ4681T1	<b>MMSZ5221BT1</b>	
2.5		MMBZ5222BLT1			<b>MMSZ5222BT1</b>	
2.7	BZX84C2V7LT1	MMBZ5223BLT1	MMSZ2V7T1	MMSZ4682T1	MMSZ5223BT1	
2.8		MMBZ5224BLT1			MMSZ5224BT1	
3.0	BZX84C3V0LT1	MMBZ5225BLT1	MMSZ3V0T1	MMSZ4683T1	<b>MMSZ5225BT1</b>	
3.3	BZX84C3V3LT1	MMBZ5226BLT1	MMSZ3V3T1	MMSZ4684T1	MMSZ5226BT1	1SMB5913BT3
3.6	BZX84C3V6LT1	MMBZ5227BLT1	MMSZ3V6T1	<b>MMSZ4685T1</b>	MMSZ5227BT1	1SMB5914BT3
3.9	BZX84C3V9LT1	<b>MMBZ5228BLT1</b>	MMSZ3V9T1	MMSZ4686T1	MMSZ5228BT1	1SMB5915BT3
4.3	BZX84C4V3LT1	MMBZ5229BLT1	MMSZ4V3T1	MMSZ4687T1	<b>MMSZ5229BT1</b>	1SMB5916BT3
4.7	<b>BZX84C4V7LT1</b>	MMBZ5230BLT1	MMSZ4V7T1	<b>MMSZ4688T1</b>	<b>MMSZ5230BT1</b>	1SMB5917BT3
5.1	<b>BZX84C5V1LT1</b>	<b>MMBZ5231BLT1</b>	<b>MMSZ5V1T1</b>	<b>MMSZ4689T1</b>	<b>MMSZ5231BT1</b>	1SMB5918BT3
5.6	<b>BZX84C5V6LT1</b>	<b>MMBZ5232BLT1</b>	<b>MMSZ5V6T1</b>	<b>MMSZ4690T1</b>	<b>MMSZ5232BT1</b>	1SMB5919BT3
6.0		MMBZ5233BLT1			MMSZ5233BT1	
6.2	<b>BZX84C6V2LT1</b>	<b>MMBZ5234BLT1</b>	<b>MMSZ6V2T1</b>	MMSZ4691T1	<b>MMSZ5234BT1</b>	1SMB5920BT3
6.8	BZX84C6V8LT1	<b>MMBZ5235BLT1</b>	MMSZ6V8T1	MMSZ4692T1	<b>MMSZ5235BT1</b>	1SMB5921BT3
7.5	BZX84C7V5LT1	MMBZ5236BLT1	MMSZ7V5T1	MMSZ4693T1	MMSZ5236BT1	1SMB5922BT3
8.2	BZX84C8V2LT1	MMBZ5237BLT1	MMSZ8V2T1	MMSZ4694T1	MMSZ5237BT1	1SMB5923BT3
8.7		MMBZ5238BLT1			MMSZ5238BT1	
9.1	BZX84C9V1LT1	MMBZ5239BLT1	MMSZ9V1T1	MMSZ4695T1	MMSZ5239BT1	1SMB5924BT3
10	BZX84C10LT1	<b>MMBZ5240BLT1</b>	MMSZ10T1	MMSZ4696T1	<b>MMSZ5240BT1</b>	1SMB5925BT3
11	BZX84C11LT1	MMBZ5241BLT1	MMSZ11T1	MMSZ4697T1	MMSZ5241BT1	1SMB5926BT3
12	<b>BZX84C12LT1</b>	<b>MMBZ5242BLT1</b>	MMSZ12T1	MMSZ4698T1	<b>MMSZ5242BT1</b>	1SMB5927BT3
13	BZX84C13LT1	MMBZ5243BLT1	MMSZ13T1	MMSZ4700T1	MMSZ5243BT1	1SMB5928BT3
14		MMBZ5244BLT1		MMSZ4701T1	MMSZ5244BT1	
15	BZX84C15LT1	<b>MMBZ5245BLT1</b>	MMSZ15T1	MMSZ4702T1	<b>MMSZ5245BT1</b>	1SMB5929BT3
16	BZX84C16LT1	MMBZ5246BLT1	MMSZ16T1	MMSZ4703T1	<b>MMSZ5246BT1</b>	1SMB5930BT3
17		MMBZ5247BLT1		MMSZ4704T1	MMSZ5247BT1	
18	<b>BZX84C18LT1</b>	<b>MMBZ5248BLT1</b>	<b>MMSZ18T1</b>	MMSZ4705T1	<b>MMSZ5248BT1</b>	1SMB5931BT3
19		MMBZ5249BLT1		MMSZ4706T1	MMSZ5249BT1	
20	BZX84C20LT1	<b>MMBZ5250BLT1</b>	MMSZ20T1	MMSZ4707T1	<b>MMSZ5250BT1</b>	1SMB5932BT3
22	BZX84C22LT1	MMBZ5251BLT1	MMSZ22T1	MMSZ4708T1	MMSZ5251BT1	1SMB5933BT3
24	BZX84C24LT1	MMBZ5252BLT1	MMSZ24T1	MMSZ4709T1	<b>MMSZ5252BT1</b>	1SMB5934BT3
25		MMBZ5253BLT1		MMSZ4710T1	MMSZ5253BT1	
27	BZX84C27LT1	<b>MMBZ5254BLT1</b>	MMSZ27T1	MMSZ4711T1	MMSZ5254BT1	1SMB5935BT3



\*See Notes page 5.2-23.

Devices listed in bold, italic are Motorola preferred devices.

# Zener Diodes

## Voltage Regulator Diodes (continued)

Table 15. Surface Mount Packages (continued)

Nominal Zener Breakdown Voltage	225 mW Surface Mount		500 mW Surface Mount	500 mW Low Level Surface Mount	500 mW Surface Mount	3 Watt Surface Mount
	SOT-23		SOD-123	SOD-123	SOD-123	SMB
(*Note 1)	(*Note 2)	(*Note 3)	(*Note 4)	(*Note 5)	(*Note 6)	(*Note 7)
Volts	 Anode <span style="margin-left: 100px;">Cathode</span> No Connection Plastic Case 318-07 TO-236AB		 Plastic Case 425, Style 1		 Plastic Case 403A Cathode = Notch	
28		MMBZ5255BLT1		MMSZ4712T1	MMSZ5255BT1	
30	BZX84C30LT1	MMBZ5256BLT1	MMSZ30T1	MMSZ4713T1	<b>MMSZ5256BT1</b>	1SMB5936BT3
33	BZX84C33LT1	<b>MMBZ5257BLT1</b>	MMSZ33T1	MMSZ4714T1	MMSZ5257BT1	1SMB5937BT3
36	BZX84C36LT1	MMBZ5258BLT1	MMSZ36T1	MMSZ4715T1	MMSZ5258BT1	1SMB5938BT3
39	BZX84C39LT1	MMBZ5259BLT1	<b>MMSZ39T1</b>	MMSZ4716T1	MMSZ5259BT1	1SMB5939BT3
43	BZX84C43LT1	MMBZ5260BLT1	MMSZ43T1	MMSZ4717T1	MMSZ5260BT1	1SMB5940BT3
47	BZX84C47LT1	MMBZ5261BLT1	MMSZ47T1		<b>MMSZ5261BT1</b>	1SMB5941BT3
51	BZX84C51LT1	MMBZ5262BLT1	MMSZ51T1		MMSZ5262BT1	1SMB5942BT3
56	BZX84C56LT1	MMBZ5263BLT1	MMSZ56T1		MMSZ5263BT1	1SMB5943BT3
60		MMBZ5264BLT1			MMSZ5264BT1	
62	BZX84C62LT1	MMBZ5265BLT1	MMSZ62T1		MMSZ5265BT1	1SMB5944BT3
68	BZX84C68LT1	MMBZ5266BLT1	MMSZ68T1		MMSZ5266BT1	1SMB5945BT3
75	BZX84C75LT1	MMBZ5267BLT1	MMSZ75T1		MMSZ5267BT1	1SMB5946BT3
82		MMBZ5268BLT1			MMSZ5268BT1	1SMB5947BT3
87		MMBZ5269BLT1			MMSZ5269BT1	
91		MMBZ5270BLT1			MMSZ5270BT1	1SMB5948BT3
100					MMSZ5271BT1	1SMB5949BT3
110						1SMB5950BT3
120						1SMB5951BT3
130						1SMB5952BT3
150						1SMB5953BT3
160						1SMB5954BT3
170						
180						1SMB5955BT3
200						1SMB5956BT3

\*See Notes on page 5.2-23.

5

Devices listed in bold, italic are Motorola preferred devices.

# Zener Diodes

## Notes — Surface Mount Chart

1. *Zener Voltage* is the key parameter for each device type. It is specified at a particular test current applied at either thermal equilibrium (T.E.) or pulse test condition. The voltage tolerance for the device types listed is, in general  $\pm 5\%$ ; however, for some series, the voltage tolerance varies from device type to device type over a range of  $\pm(5$  to  $8.5)\%$ . Consult the complete data sheet to determine the exact test conditions and minimum/maximum limits for the zener voltage.

*Power Ratings* represent the capability of the case size listed as supplied by Motorola. These ratings may be higher than the same device types supplied by other manufacturers.

### $V_Z$ TEST CONDITIONS AND TOLERANCES

2. *BZX84C2V4L-C24LT1*  $I_{ZT} = 5$  mA (pulse).

*BZX84C27L-C75LT1*

$I_{ZT} = 2$  mA (pulse).

Tolerance is  $\pm(5$  to  $8.5)\%$  depending on type number. Each device type also has other  $V_Z$  min/max limits at two other  $I_{ZT}$  pulse current values.

3. *MMBZ5221BL-42BLT1*  $I_{ZT} = 20$  mA (pulse).

*MMBZ5243BL-70BLT1*

$I_{ZT}$  @ approximately 125 mW point (pulse).

BL suffix =  $\pm 5\%$ .

4. *MMSZ2V4-24T1*

*MMSZ27-56T1*

$I_{ZT} = 5$  mA (pulse).

$I_{ZT} = 2$  mA (pulse).

Tolerance is  $\pm(5$  to  $8.5)\%$  depending on type number. Each device type also has other  $V_Z$  min/max limits at two other  $I_{ZT}$  pulse current values.

5. *MMSZ4678T1 Series*

$I_{ZT} = 50$   $\mu$ A (T.E.).

No suffix =  $\pm 5\%$ .

6. *MMSZ5221B-42BT1*

*MMSZ5243B-63BT1*

$I_{ZT} = 20$  mA (T.E.).

$I_{ZT}$  @ approximately 125 mW point (T.E.).

A suffix =  $\pm 10\%$ .

B suffix =  $\pm 5\%$ .

7. *1SMB5913BT3 Series*

$I_{ZT}$  @ approximately 375 mW point (T.E.).

BT3 suffix =  $\pm 5\%$ .

T3 suffix designates tape and reel of 2500 units.

5



# Zener Diodes

Table 16. 225 mW Rating on FR-5 Board – Case 318-07 – SOT-23

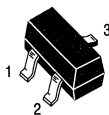
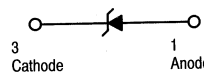
**CASE 318-07, STYLE 8**  
**SOT-23 (TO-236AB)**  
**PLASTIC**

**ELECTRICAL CHARACTERISTICS (Pinout: 1-Anode, 2-NC, 3-Cathode) ( $V_F = 0.9\text{ V Max @ } I_F = 10\text{ mA}$  for all types)**

Type Number	Marking	Zener Voltage $V_{Z1}$ (Volts) @ $I_{ZT1} = 5\text{ mA}$ (20)			Max Zener Impedance $Z_{ZT1}$ (Ohms) @ $I_{ZT1} = 5\text{ mA}$	Max Reverse Leakage Current		Zener Voltage $V_{Z2}$ (Volts) @ $I_{ZT2} = 1\text{ mA}$ (20)		Max Zener Impedance $Z_{ZT2}$ (Ohms) @ $I_{ZT2} = 1\text{ mA}$	Zener Voltage $V_{Z3}$ (Volts) @ $I_{ZT3} = 20\text{ mA}$ (20)		Max Zener Impedance $Z_{ZT3}$ (Ohms) @ $I_{ZT3} = 20\text{ mA}$	$dV_Z/dI$ (mV/k) @ $I_{ZT1} = 5\text{ mA}$		$C_{pF}$ Max @ $V_R = 0$ $f = 1\text{ MHz}$
		Min	Max	$I_R$ mA		$V_R$ Volts	Min	Max	Min		Max	Min		Max		
		Nom	Min	Max												
BZX84C2V4LT1	Z11	2.4	2.2	2.6	100	50	1	1.7	2.1	600	2.6	3.2	50	-3.5	0	450
BZX84C2V7LT1	Z12	2.7	2.5	2.9	100	20	1	1.9	2.4	600	3	3.6	50	-3.5	0	450
BZX84C3V0LT1	Z13	3	2.8	3.2	95	10	1	2.1	2.7	600	3.3	3.9	50	-3.5	0	450
BZX84C3V3LT1	Z14	3.3	3.1	3.5	95	5	1	2.3	2.9	600	3.6	4.2	40	-3.5	0	450
BZX84C3V6LT1	Z15	3.6	3.4	3.8	90	5	1	2.3	3.3	600	3.9	4.5	40	-3.5	0	450
BZX84C3V9LT1	Z16	3.9	3.7	4.1	90	3	1	2.9	3.5	600	4.1	4.7	30	-3.5	-2.5	450
BZX84C4V3LT1	W9	4.3	4	4.6	90	3	1	3.3	4	600	4.4	5.1	30	-3.5	0	450
<b>BZX84C4V7LT1</b>	Z1	4.7	4.4	5	80	3	2	3.7	4.7	500	4.5	5.4	15	-3.5	0.2	260
<b>BZX84C5V1LT1</b>	Z2	5.1	4.8	5.4	60	2	2	4.2	5.3	480	5	5.9	15	-2.7	1.2	225
<b>BZX84C5V6LT1</b>	Z3	5.6	5.2	6	40	1	2	4.8	6	400	5.2	6.3	10	-2.0	2.5	200
<b>BZX84C6V2LT1</b>	Z4	6.2	5.8	6.6	10	3	4	5.6	6.6	150	5.8	6.8	6	0.4	3.7	185
BZX84C6V8LT1	Z5	6.8	6.4	7.2	15	2	4	6.3	7.2	80	6.4	7.4	6	1.2	4.5	155
BZX84C7V5LT1	Z6	7.5	7	7.9	15	1	5	6.9	7.9	80	7	8	6	2.5	5.3	140
BZX84C8V2LT1	Z7	8.2	7.7	8.7	15	0.7	5	7.6	8.7	80	7.7	8.8	6	3.2	6.2	135
BZX84C9V1LT1	Z8	9.1	8.5	9.6	15	0.5	6	8.4	9.6	100	8.5	9.7	8	3.8	7.0	130
BZX84C10LT1	Z9	10	9.4	10.6	20	0.2	7	9.3	10.6	150	9.4	10.7	10	4.5	8.0	130
BZX84C11LT1	Y1	11	10.4	11.6	20	0.1	8	10.2	11.6	150	10.4	11.8	10	5.4	9.0	130
<b>BZX84C12LT1</b>	Y2	12	11.4	12.7	25	0.1	8	11.2	12.7	150	11.4	12.9	10	6.0	10.0	130
BZX84C13LT1	Y3	13	12.4	14.1	30	0.1	8	12.3	14	170	12.5	14.2	15	7.0	11.0	120
BZX84C15LT1	Y4	15	13.8	15.6	30	0.05	10.5	13.7	15.5	200	13.9	15.7	20	9.2	13.0	110
BZX84C16LT1	Y5	16	15.3	17.1	40	0.05	11.2	15.2	17	200	15.4	17.2	20	10.4	14.0	105
<b>BZX84C18LT1</b>	Y6	18	16.8	19.1	45	0.05	12.6	16.7	19	225	16.9	19.2	20	12.4	16.0	100
BZX84C20LT1	Y7	20	18.8	21.2	55	0.05	14	18.7	21.1	225	18.9	21.4	20	14.4	18.0	85
BZX84C22LT1	Y8	22	20.8	23.3	55	0.05	15.4	20.7	23.2	250	20.9	23.4	25	16.4	20.0	85
BZX84C24LT1	Y9	24	22.8	25.6	70	0.05	16.8	22.7	25.5	250	22.9	25.7	25	18.4	22.0	80
		$V_{Z1}$ Below @ $I_{ZT1} = 2\text{ mA}$			$Z_{ZT1}$ Below @ $I_{ZT1} = 2\text{ mA}$			$V_{Z2}$ Below @ $I_{ZT2} = 0.1\text{ mA}$		$Z_{ZT2}$ Below @ $I_{ZT2} = 0.5\text{ mA}$ (23)	$V_{Z3}$ Below @ $I_{ZT3} = 10\text{ mA}$		$Z_{ZT3}$ Below @ $I_{ZT3} = 10\text{ mA}$	$dV_Z/dI$ (mV/k) Below @ $I_{ZT1} = 2\text{ mA}$		
BZX84C27LT1	Y10	27	25.1	28.9	80	0.05	18.9	25	28.9	300	25.2	29.3	45	21.4	25.3	70
BZX84C30LT1	Y11	30	28	32	80	0.05	21	27.8	32	300	28.1	32.4	50	24.4	29.4	70
BZX84C33LT1	Y12	33	31	35	80	0.05	23.1	30.8	35	325	31.1	35.4	55	27.4	33.4	70
BZX84C36LT1	Y13	36	34	38	90	0.05	25.2	33.8	38	350	34.1	38.4	60	30.4	37.4	70
BZX84C39LT1	Y14	39	37	41	130	0.05	27.3	36.7	41	350	37.1	41.5	70	33.4	41.2	45
BZX84C43LT1	Y15	43	40	46	150	0.05	30.1	39.7	46	375	40.1	46.5	80	37.6	46.6	40
BZX84C47LT1	Y16	47	44	50	170	0.05	32.9	43.7	50	375	44.1	50.5	90	42.0	51.8	40
BZX84C51LT1	Y17	51	48	54	180	0.05	35.7	47.6	54	400	48.1	54.6	100	46.6	57.2	40
BZX84C56LT1	Y18	56	52	60	200	0.05	39.2	51.5	60	425	52.1	60.8	110	52.2	63.8	40
BZX84C62LT1	Y19	62	58	66	215	0.05	43.4	57.4	66	450	58.2	67	120	58.8	71.6	35
BZX84C68LT1	Y20	68	64	72	240	0.05	47.6	63.4	72	475	64.2	73.2	130	65.6	79.8	35
BZX84C75LT1	Y21	75	70	79	255	0.05	52.5	69.4	79	500	70.3	80.2	140	73.4	88.6	35

(20)  $V_Z$  is measured with a pulse test current ( $I_{ZT}$ ) applied at an ambient temperature of 25°C.  
 (23) The zener impedance,  $Z_{ZT2}$ , for the 27 through 75 volt types is tested at 0.5 mA rather than the test current of 0.1 mA used for  $V_{Z2}$ .

Devices listed in bold, italic are Motorola preferred devices.

# Zener Diodes

Table 17. 225 mW Rating on FR-5 Board – Case 318-07 – SOT-23

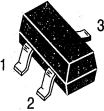
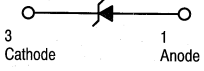
**CASE 318-07, STYLE 8  
SOT-23 (TO-236AB)  
PLASTIC**

**ELECTRICAL CHARACTERISTICS (Pinout: 1–Anode, 2–NC, 3–Cathode)** ( $V_F = 0.9\text{ V Max @ } I_F = 10\text{ mA}$  for all types.)

Device	Marking	Test Current $I_{ZT}$ mA	Zener Voltage $V_Z (\pm 5\%)$ Nominal (20)	$Z_{ZK}$ $I_Z = 0.25\text{ mA}$ $\Omega$ Max	$Z_{ZT}$ $I_Z = I_{ZT}$ @ 10% Mode $\Omega$ Max	Max $I_R$ $\mu\text{A}$	@	$V_R$ V
MMBZ5221BLT1	18A	20	2.4	1200	30	100		1
MMBZ5222BLT1	18B	20	2.5	1250	30	100		1
MMBZ5223BLT1	18C	20	2.7	1300	30	75		1
MMBZ5224BLT1	18D	20	2.8	1400	30	75		1
MMBZ5225BLT1	18E	20	3	1600	29	50		1
MMBZ5226BLT1	8A	20	3.3	1600	28	25		1
MMBZ5227BLT1	8B	20	3.6	1700	24	15		1
<b>MMBZ5228BLT1</b>	8C	20	3.9	1900	23	10		1
MMBZ5229BLT1	8D	20	4.3	2000	22	5		1
MMBZ5230BLT1	8E	20	4.7	1900	19	5		2
<b>MMBZ5231BLT1</b>	8F	20	5.1	1600	17	5		2
<b>MMBZ5232BLT1</b>	8G	20	5.6	1600	11	5		3
MMBZ5233BLT1	8H	20	6	1600	7	5		3.5
<b>MMBZ5234BLT1</b>	8J	20	6.2	1000	7	5		4
<b>MMBZ5235BLT1</b>	8K	20	6.8	750	5	3		5
MMBZ5236BLT1	8L	20	7.5	500	6	3		6
MMBZ5237BLT1	8M	20	8.2	500	8	3		6.5
MMBZ5238BLT1	8N	20	8.7	600	8	3		6.5
MMBZ5239BLT1	8P	20	9.1	600	10	3		7
<b>MMBZ5240BLT1</b>	8Q	20	10	600	17	3		8
MMBZ5241BLT1	8R	20	11	600	22	2		8.4
<b>MMBZ5242BLT1</b>	8S	20	12	600	30	1		9.1
MMBZ5243BLT1	8T	9.5	13	600	13	0.5		9.9
MMBZ5244BLT1	8U	9	14	600	15	0.1		10
<b>MMBZ5245BLT1</b>	8V	8.5	15	600	16	0.1		11
MMBZ5246BLT1	8W	7.8	16	600	17	0.1		12
MMBZ5247BLT1	8X	7.4	17	600	19	0.1		13
<b>MMBZ5248BLT1</b>	8Y	7	18	600	21	0.1		14
MMBZ5249BLT1	8Z	6.6	19	600	23	0.1		14
<b>MMBZ5250BLT1</b>	81A	6.2	20	600	25	0.1		15
MMBZ5251BLT1	81B	5.6	22	600	29	0.1		17
MMBZ5252BLT1	81C	5.2	24	600	33	0.1		18
MMBZ5253BLT1	81D	5	25	600	35	0.1		19
<b>MMBZ5254BLT1</b>	81E	4.6	27	600	41	0.1		21
MMBZ5255BLT1	81F	4.5	28	600	44	0.1		21
MMBZ5256BLT1	81G	4.2	30	600	49	0.1		23
<b>MMBZ5257BLT1</b>	81H	3.8	33	700	58	0.1		25
MMBZ5258BLT1	81J	3.4	36	700	70	0.1		27
MMBZ5259BLT1	81K	3.2	39	800	80	0.1		30
MMBZ5260BLT1	81L	3	43	900	93	0.1		33

(20)  $V_Z$  is measured at pulse test current ( $I_{ZT}$ ) at an ambient temperature of 25°C.

Devices listed in bold, italic are Motorola preferred devices.

# Zener Diodes

Table 17. 225 mW Rating on FR-5 Board – Case 318-07 – SOT-23 (continued)

ELECTRICAL CHARACTERISTICS (Pinout: 1–Anode, 2–NC, 3–Cathode) ( $V_F = 0.9\text{ V Max}$ @ $I_F = 10\text{ mA}$ for all types.)							
Device	Marking	Test Current $I_{ZT}$ mA	Zener Voltage $V_Z (\pm 5\%)$ Nominal(20)	$Z_{ZK}$ $I_Z = 0.25\text{ mA}$ $\Omega$ Max	$Z_{ZT}$ $I_Z = I_{ZT}$ @ 10% Mode $\Omega$ Max	Max $I_R$ $\mu\text{A}$	@ $V_R$ V
MMBZ5261BLT1	81M	2.7	47	1000	105	0.1	36
MMBZ5262BLT1	81N	2.5	51	1100	125	0.1	39
MMBZ5263BLT1	81P	2.2	56	1300	150	0.1	43
MMBZ5264BLT1	81Q	2.1	60	1400	170	0.1	46
MMBZ5265BLT1	81R	2	62	1400	185	0.1	47
MMBZ5266BLT1	81S	1.8	68	1600	230	0.1	52
MMBZ5267BLT1	81T	1.7	75	1700	270	0.1	56
MMBZ5268BLT1	81U	1.5	82	2000	330	0.1	62
MMBZ5269BLT1	81V	1.4	87	2200	370	0.1	68
MMBZ5270BLT1	81W	1.4	91	2300	400	0.1	69

Table 18. 500 mW Rating on FR-4 or FR-5 Board – Case 425 – SOD-123

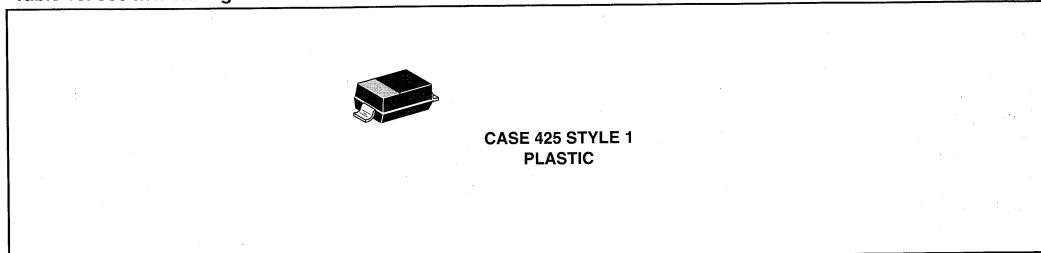

ELECTRICAL CHARACTERISTICS ( $T_A = 25^\circ\text{C}$  unless otherwise noted(24), ( $V_F = 0.9\text{ V Max}$ . @  $I_F = 10\text{ mA}$  for all types)

Type Number	Marking	Zener Voltage $V_Z @ I_{ZT}$ Volts(24)(25)			Test Voltage $V_R$ Volts	Max Zener Impedance(21)		Max Reverse Leakage Current $I_R @ V_R$ $\mu\text{A}$	Test Voltage $V_R$ Volts
		Nom	Min	Max		$Z_{ZT}$ @ $I_Z = I_{ZT}$ $\Omega$	$Z_{ZK}$ @ $I_{ZK} = 0.25\text{ mA}$ $\Omega$		
<b>MMSZ5221BT1</b>	C1	2.4	2.28	2.52	20	30	1200	100	1
<b>MMSZ5222BT1</b>	C2	2.5	2.38	2.63	20	30	1250	100	1
MMSZ5223BT1	C3	2.7	2.57	2.84	20	30	1300	75	1
MMSZ5224BT1	C4	2.8	2.66	2.94	20	30	1400	75	1
<b>MMSZ5225BT1</b>	C5	3.0	2.85	3.15	20	30	1600	50	1
MMSZ5226BT1	D1	3.3	3.14	3.47	20	28	1600	25	1
MMSZ5227BT1	D2	3.6	3.42	3.78	20	24	1700	15	1
MMSZ5228BT1	D3	3.9	3.71	4.10	20	23	1900	10	1
<b>MMSZ5229BT1</b>	D4	4.3	4.09	4.52	20	22	2000	5	1
<b>MMSZ5230BT1</b>	D5	4.7	4.47	4.94	20	19	1900	5	2

(20)  $V_Z$  is measured at pulse test current ( $I_{ZT}$ ) at an ambient temperature of  $25^\circ\text{C}$ .

(21)  $Z_{ZT}$  and  $Z_{ZK}$  are measured by dividing the AC voltage drop across the device by the AC current applied.

The specified limits are for  $I_Z(\text{AC}) = 0.1 I_Z(\text{DC})$ , with the AC frequency = 1 kHz.

(24) Nominal zener voltage is measured with the device junction in thermal equilibrium at  $T_L = 30^\circ\text{C} \pm 1^\circ\text{C}$ .

(25) All part numbers shown indicate a  $V_Z$  tolerance of  $\pm 5\%$ .

Devices listed in bold, italic are Motorola preferred devices.

# Zener Diodes

Table 18. 500 mW Rating on FR-4 or FR-5 Board – Case 425 – SOD-123 (continued)

ELECTRICAL CHARACTERISTICS (T <sub>A</sub> = 25°C unless otherwise noted <sup>(24)</sup> , (V <sub>F</sub> = 0.9 V Max. @ I <sub>F</sub> = 10 mA for all types)									
Type Number	Marking	Zener Voltage V <sub>Z</sub> @ I <sub>ZT</sub> Volts <sup>(24)</sup> <sup>(25)</sup>			Test Voltage V <sub>R</sub> Volts	Max Zener Impedance <sup>(21)</sup>		Max Reverse Leakage Current I <sub>R</sub> @ V <sub>R</sub> μA	Test Voltage V <sub>R</sub> Volts
		Nom	Min	Max		Z <sub>ZT</sub> @ I <sub>Z</sub> = I <sub>ZT</sub> Ω	Z <sub>ZK</sub> @ I <sub>ZK</sub> = 0.25 mA Ω		
<b>MMSZ5231BT1</b>	E1	5.1	4.85	5.36	20	17	1600	5	2
<b>MMSZ5232BT1</b>	E2	5.6	5.32	5.88	20	11	1600	5	3
<b>MMSZ5233BT1</b>	E3	6.0	5.70	6.30	20	7	1600	5	3.5
<b>MMSZ5234BT1</b>	E4	6.2	5.89	6.51	20	7	1000	5	4
<b>MMSZ5235BT1</b>	E5	6.8	6.46	7.14	20	5	750	3	5
MMSZ5236BT1	F1	7.5	7.13	7.88	20	6	500	3	6
MMSZ5237BT1	F2	8.2	7.79	8.61	20	8	500	3	6.5
MMSZ5238BT1	F3	8.7	8.27	9.14	20	8	600	3	6.5
MMSZ5239BT1	F4	9.1	8.65	9.56	20	10	600	3	7
<b>MMSZ5240BT1</b>	F5	10	9.50	10.50	20	17	600	3	8
MMSZ5241BT1	H1	11	10.45	11.55	20	22	600	2	8.4
<b>MMSZ5242BT1</b>	H2	12	11.40	12.60	20	30	600	1	9.1
MMSZ5243BT1	H3	13	12.35	13.65	9.5	13	600	0.5	9.9
MMSZ5244BT1	H4	14	13.30	14.70	9.0	15	600	0.1	10
<b>MMSZ5245BT1</b>	H5	15	14.25	15.75	8.5	16	600	0.1	11
<b>MMSZ5246BT1</b>	J1	16	15.20	16.80	7.8	17	600	0.1	12
MMSZ5247BT1	J2	17	16.15	17.85	7.4	19	600	0.1	13
<b>MMSZ5248BT1</b>	J3	18	17.10	18.90	7.0	21	600	0.1	14
MMSZ5249BT1	J4	19	18.05	19.95	6.6	23	600	0.1	14
<b>MMSZ5250BT1</b>	J5	20	19.00	21.00	6.2	25	600	0.1	15
MMSZ5251BT1	K1	22	20.90	23.10	5.6	29	600	0.1	17
<b>MMSZ5252BT1</b>	K2	24	22.80	25.20	5.2	33	600	0.1	18
MMSZ5253BT1	K3	25	23.75	26.25	5.0	35	600	0.1	19
<b>MMSZ5254BT1</b>	K4	27	25.65	28.35	4.6	41	600	0.1	21
MMSZ5255BT1	K5	28	26.60	29.40	4.5	44	600	0.1	21
<b>MMSZ5256BT1</b>	M1	30	28.50	31.50	4.2	49	600	0.1	23
MMSZ5257BT1	M2	33	31.35	34.65	3.8	58	700	0.1	25
MMSZ5258BT1	M3	36	34.20	37.80	3.4	70	700	0.1	27
MMSZ5259BT1	M4	39	37.05	40.95	3.2	80	800	0.1	30
MMSZ5260BT1	M5	43	40.85	45.15	3.0	93	900	0.1	33
<b>MMSZ5261BT1</b>	N1	47	44.65	49.35	2.7	105	1000	0.1	36
MMSZ5262BT1	N2	51	48.45	53.55	2.5	125	1100	0.1	39
MMSZ5263BT1	N3	56	53.20	58.80	2.2	150	1300	0.1	43
MMSZ5264BT1	N4	60	57.00	63.00	2.1	170	1400	0.1	46
MMSZ5265BT1	N5	62	58.90	65.10	2.0	185	1400	0.1	47
MMSZ5266BT1	P1	68	64.60	71.40	1.8	230	1600	0.1	52
MMSZ5267BT1	P2	75	71.25	78.75	1.7	270	1700	0.1	56
MMSZ5268BT1	P3	82	77.90	86.10	1.5	330	2000	0.1	62
MMSZ5269BT1	P4	87	82.65	91.35	1.4	370	2200	0.1	68
MMSZ5270BT1	P5	91	86.45	95.55	1.4	400	2300	0.1	69

(21) Z<sub>ZT</sub> and Z<sub>ZK</sub> are measured by dividing the AC voltage drop across the device by the AC current applied.

The specified limits are for I<sub>Z(AC)</sub> = 0.1 I<sub>Z(DC)</sub>, with the AC frequency = 1 kHz.

(24) Nominal zener voltage is measured with the device junction in thermal equilibrium at T<sub>L</sub> = 30°C ± 1°C.

(25) All part numbers shown indicate a V<sub>Z</sub> tolerance of ±5%.

5

Devices listed in bold, italic are Motorola preferred devices.

# Zener Diodes

Table 19. 500 mW Rating on FR-4 or FR-5 Board – Case 425 – SOD-123

ELECTRICAL CHARACTERISTICS ( $T_A = 25^\circ\text{C}$ unless otherwise noted <sup>(24)</sup> , ( $V_F = 0.9\text{ V Max. @ } I_F = 10\text{ mA}$ for all types)						
Type Number	Marking	Zener Voltage $V_Z @ I_{ZT} = 50\ \mu\text{A}$ Volts <sup>(24)(25)</sup>			Max Reverse Leakage Current $I_R @ V_R$ $\mu\text{A}$	Test Voltage $V_R$ Volts
		Nom	Min	Max		
MMSZ4678T1	CC	1.8	1.71	1.89	7.5	1
MMSZ4679T1	CD	2.0	1.90	2.10	5	1
<b>MMSZ4680T1</b>	CE	2.2	2.09	2.31	4	1
MMSZ4681T1	CF	2.4	2.28	2.52	2	1
MMSZ4682T1	CH	2.7	2.57	2.84	1	1
MMSZ4683T1	CJ	3.0	2.85	3.15	0.8	1
MMSZ4684T1	CK	3.3	3.14	3.47	7.5	1.5
<b>MMSZ4685T1</b>	CM	3.6	3.42	3.78	7.5	2
MMSZ4686T1	CN	3.9	3.71	4.10	5	2
MMSZ4687T1	CP	4.3	4.09	4.52	4	2
<b>MMSZ4688T1</b>	CT	4.7	4.47	4.94	10	3
<b>MMSZ4689T1</b>	CU	5.1	4.85	5.36	10	3
<b>MMSZ4690T1</b>	CV	5.6	5.32	5.88	10	4
MMSZ4691T1	CA	6.2	5.89	6.51	10	5
MMSZ4692T1	CX	6.8	6.46	7.14	10	5.1
MMSZ4693T1	CY	7.5	7.13	7.88	10	5.7
MMSZ4694T1	CZ	8.2	7.79	8.61	1	6.2
MMSZ4695T1	DC	8.7	8.27	9.14	1	6.6
MMSZ4696T1	DD	9.1	8.65	9.56	1	6.9
MMSZ4697T1	DE	10	9.50	10.50	1	7.6
MMSZ4698T1	DF	11	10.45	11.55	0.05	8.4
MMSZ4699T1	DH	12	11.40	12.60	0.05	9.1
MMSZ4700T1	DJ	13	12.35	13.65	0.05	9.8
MMSZ4701T1	DK	14	13.30	14.70	0.05	10.6
MMSZ4702T1	DM	15	14.25	15.75	0.05	11.4
MMSZ4703T1	DN	16	15.20	16.80	0.05	12.1
MMSZ4704T1	DP	17	16.15	17.85	0.05	12.9
MMSZ4705T1	DT	18	17.10	18.90	0.05	13.6
MMSZ4706T1	DU	19	18.05	19.95	0.05	14.4
MMSZ4707T1	DV	20	19.00	21.00	0.01	15.2
MMSZ4708T1	DA	22	20.90	23.10	0.01	16.7
MMSZ4709T1	DZ	24	22.80	25.20	0.01	18.2
MMSZ4710T1	DY	25	23.75	26.25	0.01	19.00
MMSZ4711T1	EA	27	25.65	28.35	0.01	20.4
MMSZ4712T1	EC	28	26.60	29.40	0.01	21.2
MMSZ4713T1	ED	30	28.50	31.50	0.01	22.8
MMSZ4714T1	EE	33	31.35	34.65	0.01	25.0
MMSZ4715T1	EF	36	34.20	37.80	0.01	27.3
MMSZ4716T1	EH	39	37.05	40.95	0.01	29.6
MMSZ4717T1	EJ	43	40.85	45.15	0.01	32.6

<sup>(24)</sup> Nominal zener voltage is measured with the device junction in thermal equilibrium at  $T_L = 30^\circ\text{C} \pm 1^\circ\text{C}$ .

<sup>(25)</sup> All part numbers shown indicate a  $V_Z$  tolerance of  $\pm 5\%$ .

Devices listed in bold, italic are Motorola preferred devices.

5

# Zener Diodes

Table 20. 500 mW Rating on FR-4 or FR-5 Board — Case 425 — SOD-123

ELECTRICAL CHARACTERISTICS ( $T_A = 25^\circ\text{C}$ unless otherwise noted <sup>(25)</sup> , ( $V_F = 0.9\text{ V Max.}$ @ $I_F = 10\text{ mA}$ for all types)										
Type Number	Marking	Zener Voltage $V_{Z1}$ (Volts) @ $I_{ZT1} = 5\text{ mA}$ (25)(27)			Max Zener Impedance $Z_{ZT1}$ @ $I_{ZT1} = 5\text{ mA}$ (21) $\Omega$	Max Reverse Leakage Current		Zener Voltage $V_{Z2}$ (Volts) @ $I_{ZT2} = 1\text{ mA}$ (27)		Max Zener Impedance $Z_{ZT2}$ @ $I_{ZT1} = 1\text{ mA}$ (21) $\Omega$
		Nom	Min	Max		$I_R$ $\mu\text{A}$	@ $V_R$ Volts	Min	Max	
MMSZ2V4T1	T1	2.4	2.28	2.52	100	50	1	1.7	2.1	600
MMSZ2V7T1	T2	2.7	2.57	2.84	100	20	1	1.9	2.4	600
MMSZ3V0T1	T3	3.0	2.85	3.15	95	10	1	2.1	2.7	600
MMSZ3V3T1	T4	3.3	3.14	3.47	95	5	1	2.3	2.9	600
MMSZ3V6T1	T5	3.6	3.42	3.78	90	5	1	2.7	3.3	600
MMSZ3V9T1	U1	3.9	3.71	4.10	90	3	1	2.9	3.5	600
MMSZ4V3T1	U2	4.3	4.09	4.52	90	3	1	3.3	4.0	600
MMSZ4V7T1	U3	4.7	4.47	4.94	80	3	2	3.7	4.7	500
<b>MMSZ5V1T1</b>	U4	5.1	4.85	5.36	60	2	2	4.2	5.3	480
<b>MMSZ5V6T1</b>	U5	5.6	5.32	5.88	40	1	2	4.8	6.0	400
<b>MMSZ6V2T1</b>	V1	6.2	5.89	6.51	10	3	4	5.6	6.6	150
MMSZ6V8T1	V2	6.8	6.46	7.14	15	2	4	6.3	7.2	80
MMSZ7V5T1	V3	7.5	7.13	7.88	15	1	5	6.9	7.9	80
MMSZ8V2T1	V4	8.2	7.79	8.61	15	0.7	5	7.6	8.7	80
MMSZ9V1T1	V5	9.1	8.65	9.56	15	0.5	6	8.4	9.6	100
MMSZ10T1	A1	10	9.50	10.50	20	0.2	7	9.3	10.6	150
MMSZ11T1	A2	11	10.45	11.55	20	0.1	8	10.2	11.6	150
MMSZ12T1	A3	12	11.40	12.60	25	0.1	8	11.2	12.7	150
MMSZ13T1	A4	13	12.35	13.65	30	0.1	8	12.3	14.0	170
MMSZ15T1	A5	15	14.25	15.75	30	0.05	10.5	13.7	15.5	200
MMSZ16T1	X1	16	15.20	16.80	40	0.05	11.2	15.2	17.0	200
<b>MMSZ18T1</b>	X2	18	17.10	18.90	45	0.05	12.6	16.7	19.0	225
MMSZ20T1	X3	20	19.00	21.00	55	0.05	14	18.7	21.1	225
MMSZ22T1	X4	22	20.80	23.10	55	0.05	15.4	20.7	23.2	250
MMSZ24T1	X5	24	22.80	25.20	70	0.05	16.8	22.7	25.5	250

(21)  $Z_{ZT}$  and  $Z_{ZK}$  are measured by dividing the AC voltage drop across the device by the AC current applied.

The specified limits are for  $I_{Z(AC)} = 0.1 I_{Z(DC)}$ , with the AC frequency = 1 kHz.

(24) Nominal zener voltage is measured with the device junction in thermal equilibrium at  $T_L = 30^\circ\text{C} \pm 1^\circ\text{C}$ .

(25) All part numbers shown indicate a  $V_Z$  tolerance of  $\pm 5\%$ .

(27) Zener voltage is measured with the zener current applied for  $PW = 1.0\text{ ms}$ .

5

Devices listed in bold, italic are Motorola preferred devices.

# Zener Diodes

Table 21. 500 mW Rating on FR-4 or FR-5 Board — Case 425 — SOD-123

Type Number	Marking	Zener Voltage V <sub>Z1</sub> (Volts) @ I <sub>ZT1</sub> = 2 mA (25)(27)			Max Zener Impedance Z <sub>ZT1</sub> @ I <sub>ZT1</sub> = 2 mA (21) Ω	Max Reverse Leakage Current		Zener Voltage V <sub>Z2</sub> (Volts) @ I <sub>ZT2</sub> = 0.1 mA (27)		Max Zener Impedance Z <sub>ZT2</sub> @ I <sub>ZT1</sub> = 0.5 mA (21)(23) Ω
		Nom	Min	Max		I <sub>R</sub> μA	@ V <sub>R</sub> Volts	Min	Max	
MMSZ27T1	Y1	27	25.65	28.35	80	0.05	18.9	25	28.9	300
MMSZ30T1	Y2	30	28.50	31.50	80	0.05	21	27.8	32	300
MMSZ33T1	Y3	33	31.35	34.65	80	0.05	23.1	30.8	35	325
MMSZ36T1	Y4	36	34.20	37.80	90	0.05	25.2	33.8	38	350
<b>MMSZ39T1</b>	Y5	39	37.05	40.95	130	0.05	27.3	36.7	41	350
MMSZ43T1	Z1	43	40.85	45.15	150	0.05	30.1	39.7	46	375
MMSZ47T1	Z2	47	44.65	49.35	170	0.05	32.9	43.7	50	375
MMSZ51T1	Z3	51	48.45	53.55	180	0.05	35.7	47.6	54	400
MMSZ56T1	Z4	56	53.20	58.80	200	0.05	39.2	51.5	60	425
MMSZ62T1	Z5	62	58.90	65.10	215	0.05	43.4	57.4	66	450
MMSZ68T1	Z6	68	64.60	71.40	240	0.05	47.6	63.4	72	475
MMSZ75T1	Z7	75	71.25	78.75	255	0.05	52.5	69.4	79	500

(21) Z<sub>ZT</sub> and Z<sub>ZK</sub> are measured by dividing the AC voltage drop across the device by the AC current applied. The specified (imits are for I<sub>Z(AC)</sub> = 0.1 I<sub>Z(DC)</sub>, with the AC frequency = 1 kHz

(23) The zener impedance, Z<sub>ZT2</sub>, for the 27 through 75 volt types is tested at 0.5 mA rather than the test current of 0.1 mA used for V<sub>Z2</sub>.

(25) All part numbers shown indicate a V<sub>Z</sub> tolerance of ±5%

(27) Zener voltage is measured with the zener current applied for PW = 1.0 ms.

5

Devices listed in bold, italic are Motorola preferred devices.

# Zener Diodes

## Voltage Reference Diodes

### Temperature Compensated Reference Devices

For applications where output voltage must remain within narrow limits during changes in input voltage, load resistance and temperature. Motorola guarantees all reference devices to fall within the specified maximum voltage variations,  $\Delta V_Z$ , at the specifically indicated test temperatures and test current (JEDEC Standard #5). Temperature coefficient is also specified but should be considered as a reference only — not a maximum rating.

Devices in this table are hermetically sealed structures.

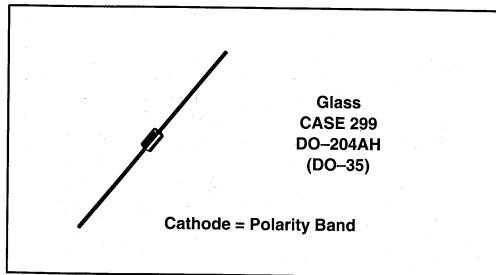

Table 22. Temperature Compensated Reference Devices

V <sub>Z</sub> Volts	Test Current mAdc	Test(2) Temp Points	AVERAGE TEMPERATURE COEFFICIENT OVER THE OPERATING RANGE									
			0.01 %/°C		0.005 %/°C		0.002 %/°C		0.001 %/°C		0.0005 %/°C	
			Device Type	$\Delta V_Z$ Max Volts	Device Type	$\Delta V_Z$ Max Volts	Device Type	$\Delta V_Z$ Max Volts	Device Type	$\Delta V_Z$ Max Volts	Device Type	$\Delta V_Z$ Max Volts
6.2(1)	7.5	A	<b>1N821</b>	0.096	<b>1N823</b>	0.048	<b>1N825</b>	0.019	1N827	0.009	1N829	0.005
6.2(1)	7.5	A	<b>1N821A</b>	0.096	<b>1N823A</b>	0.048	<b>1N825A</b>	0.019	1N827A	0.009	1N829A	0.005

(1) Non-suffix —  $Z_{ZT} = 15$  ohms, "A" Suffix —  $Z_{ZT} = 10$  ohms

(2) Test Temperature Points °C: A = -55, 0, +25, +75, +100

## Current Regulator Diodes

High impedance diodes whose "constant current source" characteristic complements the "constant voltage" of the zener line. Currents are available from 0.22 to 4.7 mA, with usable voltage range from a minimum limit of 1.0 to 2.5 Volts, up to a voltage compliance of 100 Volts, for the 1N5283 series.

5

Table 23. Current Regulator Diodes

ELECTRICAL CHARACTERISTICS (T <sub>A</sub> = 25°C unless otherwise noted)						
Type No.	Regulator Current I <sub>p</sub> (mA) @ V <sub>T</sub> = 25 V			Minimum Dynamic Impedance @ V <sub>T</sub> = 25 V Z <sub>T</sub> (MΩ)	Minimum Knee Impedance @ V <sub>K</sub> = 6.0 V Z <sub>K</sub> (MΩ)	Maximum Limiting Voltage @ I <sub>L</sub> = 0.8 I <sub>p</sub> (min) V <sub>L</sub> (Volts)
	Nom	Min	Max			
<b>1N5283</b>	0.22	0.198	0.242	25.0	2.75	1.00
1N5284	0.24	0.216	0.264	19.0	2.35	1.00
1N5285	0.27	0.243	0.297	14.0	1.95	1.00
1N5286	0.30	0.270	0.330	9.0	1.60	1.00
<b>1N5287</b>	0.33	0.297	0.363	6.6	1.35	1.00

Devices listed in bold, italic are Motorola preferred devices.



# Zener Diodes

Table 23. Current Regulator Diodes (continued)

ELECTRICAL CHARACTERISTICS ( $T_A = 25^\circ\text{C}$ unless otherwise noted)						
Type No.	Regulator Current $I_p$ (mA) @ $V_T = 25\text{ V}$			Minimum Dynamic Impedance @ $V_T = 25\text{ V}$ $Z_T$ (M $\Omega$ )	Minimum Knee Impedance @ $V_K = 6.0\text{ V}$ $Z_K$ (M $\Omega$ )	Maximum Limiting Voltage @ $I_L = 0.8 I_p$ (min) $V_L$ (Volts)
	Nom	Min	Max			
1N5288	0.39	0.351	0.429	4.10	1.00	1.05
1N5289	0.43	0.387	0.473	3.30	0.870	1.05
<b>1N5290</b>	0.47	0.423	0.517	2.70	0.750	1.05
<b>1N5291</b>	0.56	0.504	0.616	1.90	0.580	1.10
1N5292	0.62	0.558	0.682	1.55	0.470	1.13
1N5293	0.68	0.612	0.748	1.35	0.400	1.15
1N5294	0.75	0.675	0.825	1.15	0.335	1.20
1N5295	0.82	0.738	0.902	1.00	0.290	1.25
1N5296	0.91	0.819	1.001	0.880	0.240	1.29
<b>1N5297</b>	1.00	0.900	1.100	0.800	0.205	1.35
<b>1N5298</b>	1.10	0.990	1.210	0.700	0.180	1.40
<b>1N5299</b>	1.20	1.08	1.32	0.640	0.155	1.45
1N5300	1.30	1.17	1.43	0.580	0.135	1.50
1N5301	1.40	1.26	1.54	0.540	0.115	1.55
<b>1N5302</b>	1.50	1.35	1.65	0.510	0.105	1.60
1N5303	1.60	1.44	1.76	0.475	0.092	1.65
1N5304	1.80	1.62	1.98	0.420	0.074	1.75
<b>1N5305</b>	2.00	1.80	2.20	0.395	0.061	1.85
<b>1N5306</b>	2.20	1.98	2.42	0.370	0.052	1.95
<b>1N5307</b>	2.40	2.16	2.64	0.345	0.044	2.00
1N5308	2.70	2.43	2.97	0.320	0.035	2.15
<b>1N5309</b>	3.00	2.70	3.30	0.300	0.029	2.25
1N5310	3.30	2.97	3.63	0.280	0.024	2.35
1N5311	3.60	3.24	3.96	0.265	0.020	2.50
<b>1N5312</b>	3.90	3.51	4.29	0.255	0.017	2.60
<b>1N5313</b>	4.30	3.87	4.73	0.245	0.014	2.75
<b>1N5314</b>	4.70	4.23	5.17	0.235	0.012	2.90

5

Devices listed in bold, italic are Motorola preferred devices.

# Hybrid Power Module Operation

---

## In Brief . . .

The Motorola Semiconductor Products Sector is proud to announce the formation of a new group: Hybrid Power Modules. Our operation has been in existence since August of 1992, and we're chartering new ground to become the world's fastest supplier of intelligent, energy efficient power modules for motor drive and uninterruptable power supply applications.

It's an exciting market, with 50 million motors being manufactured per year, and fewer than 5% of those using electronically controlled drives. Motorola Hybrid Power Modules will play a major role in supplying those power modules.

With Motorola's technology breadth, we're well positioned to develop highly integrated, intelligent IGBT (insulated gate bipolar transistor) power modules. The IGBT technology combines high current handling capability with low input current requirements in a smaller form factor which enables the design of more compact inverters. We have the capabilities to support custom modules (based on annual volume requirements) and offer the fastest possible time to market. Present integrated IGBT modules range from 5 to 30 amps, 600 and 1200 volts are also in our product portfolio. Our plans for the future include a family of advanced modules for applications in higher current and higher voltage devices and control networks.

To summarize, we believe that we offer the leading edge technology combined with a state-of-the-art flexible manufacturing line and rapid cycle time that can give you the unique ability to differentiate your products in this highly competitive market.

	Page
Integrated Power Stage IGBT .....	5.3-2

**5**

**Table 1. Integrated Power Stage IGBT**

V <sub>CES</sub> (V)	Maximum Ratings				
	I <sub>C</sub> (A)				
	5	10	15	20	30
600			<i>MHPM7A15A60A</i> 6/94(1)	<i>MHPM7A20A60A</i> 10/94(1)	<i>MHPM7A30A60B</i> 11/94(1)
1200	<i>MHPM7A8A120A</i> 7/94(1)	<i>MHPM7A12A120A</i> 11/94(1)	<i>MHPM7A16A120B</i> 12/94(1)		

(1) Date when product will be available.

**CIRCUIT**

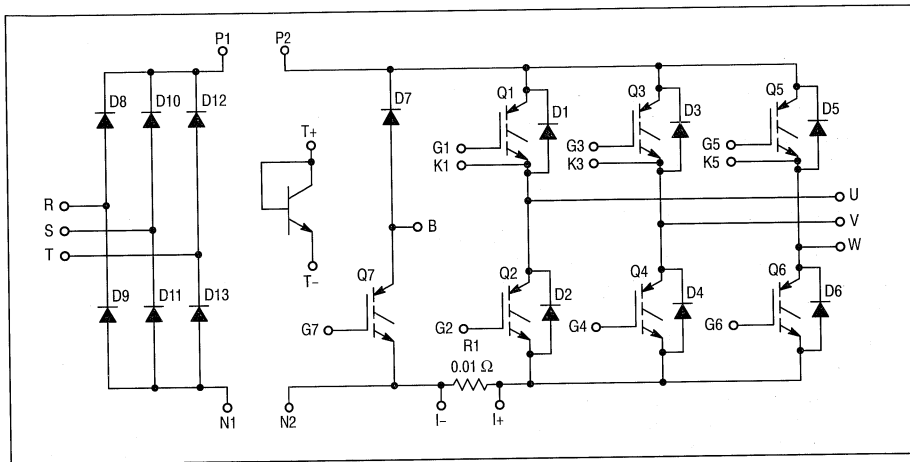

Includes optional sense resistor and temperature sensor.

**5**

**Benefits of Motorola Integrated Power Stage**

- combines a 3-phase input rectifier bridge, output inverter and brake transistor in one package
- utilizes Motorola's advanced 600 & 1200 V IGBTs with matched soft free-wheeling diodes
- positive and negative bus access to designer
- temperature and current sense integrated in module

Devices listed in bold, italic are Motorola preferred devices.

# TMOS Power MOSFETs Products

---

## In Brief . . .

Motorola continues to build a world class portfolio of TMOS Power MOSFETs with new advances in silicon and packaging technology. The following new advances have been made in the area of silicon technology.

- Additional high voltage devices with voltages up to 1200 volts.
- The new High Cell Density (HDTMOS) Family of standard and Logic Level devices in both N and P-channel are available in DPAK, D<sup>2</sup>PAK and SO-8 surface mount packages and in the industry standard TO-220 package.

The following new advances have been made in the area of packaging technology.

- Motorola has added SO-8 (MiniMOS) and SOT-223 packages to the surface mount portfolio.
- New High Power packages capable of housing very large die and higher power dissipation are now available in the TO-264 (formerly TO-3PBL) and SOT-227B (Isotop) packages.

	<b>Page</b>
TMOS Power MOSFETs	5.4-1
TMOS Power MOSFETs Numbering System	5.4-2
HDTMOS™ Power MOSFETs	5.4-3
N-Channel	5.4-4
SO-8 (MiniMOS) Packages	5.4-4
SOT-223 Medium Power MOSFETs	5.4-5
DPAK	5.4-6
D <sup>2</sup> PAK	5.4-7
TO-220AB	5.4-8
Isolated TO-220	5.4-10
TO-247 Isolated Mounting Hole	5.4-11
TO-264 High Power Products	5.4-12
TO-204AA (TO-3) Metal Packages	5.4-13
P-Channel	5.4-14
SO-8 (MiniMOS) Packages	5.4-14
SOT-223 Medium Power MOSFETs	5.4-14
DPAK	5.4-15
D <sup>2</sup> PAK	5.4-15
TO-220AB	5.4-16
Isolated TO-220	5.4-16
TO-247 Isolated Mounting Hole	5.4-17
TO-204AA (TO-3) Metal Packages	5.4-17
Logic Level	5.4-18
SOT-223 Medium Power MOSFETs	5.4-18
DPAK	5.4-18
D <sup>2</sup> PAK	5.4-19
TO-220AB	5.4-19
Logic Level Power MOSFETs	5.4-20
ICePAK Multiple Chip Packages	5.4-21
Isotop Isolated SOT-227B	5.4-22
SMARTDISCRETES Products	5.4-23
TMOS V	5.4-24



# TMOS Power MOSFETs

## TMOS Power MOSFETs Numbering System

Wherever possible, Motorola has used the following numbering systems for TMOS power MOSFET products.

**MTP75N06HD**

MOTOROLA \_\_\_\_\_  
 X FOR ENGINEERING SAMPLES  
 TMOS \_\_\_\_\_  
 T FOR TMOS  
 L FOR SMARTDISCRETES  
 G FOR IGBT  
 P FOR MULTIPLE CHIP PRODUCTS

PACKAGE TYPE \_\_\_\_\_  
 P FOR PLASTIC TO-220  
 M FOR METAL TO-204 (TO-3)/ICePAK  
 D FOR DPAK  
 A FOR TO-220 ISOLATED  
 W FOR TO-247  
 B FOR D<sup>2</sup>PAK  
 Y FOR TO-264  
 E FOR SOT-227B

CURRENT \_\_\_\_\_

OPTIONAL SUFFIX:  
 L FOR LOGIC LEVEL  
 E FOR ENERGY RATED  
 T4 FOR TAPE & REEL (DPAK/D<sup>2</sup>PAK)  
 RL FOR TAPE & REEL (DPAK)  
 HD FOR HIGH CELL DENSITY  
 V FOR TMOS V

VOLTAGE RATING DIVIDED BY 10

CHANNEL POLARITY, N OR P

Example of exceptions: MTD/MTP3055E  
 MTD/MTP2955E

5

## SO-8 (MiniMOS) and SOT-223 Power MOSFETs

**MMSF4P01HDR1**

MOTOROLA \_\_\_\_\_  
 TMOS \_\_\_\_\_  
 M FOR MINIATURE

PACKAGE TYPE \_\_\_\_\_  
 DF — DUAL FET  
 SF — SINGLE FET  
 FT — FET TRANSISTOR

CURRENT \_\_\_\_\_

R1 AND R2 FOR TAPE & REEL  
 MiniMOS

OPTIONAL SUFFIX:  
 E FOR ENERGY RATED  
 HD FOR HIGH CELL DENSITY  
 L FOR LOGIC LEVEL

VOLTAGE RATING DIVIDED BY 10

CHANNEL POLARITY, N OR P  
 C FOR COMPLEMENTARY



# HDTMOS Power MOSFETs

## N and P-Channel

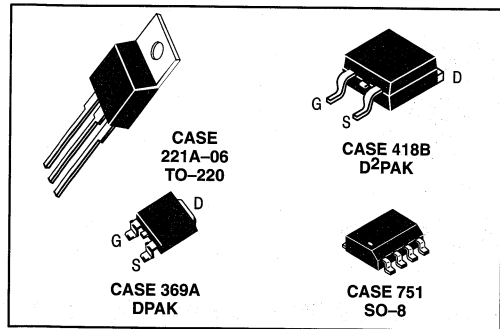

HDTMOS Technology is a design technique that reduces the on-resistance contribution in virtually every portion of the power FET. The aggressive six million cells per square inch design is easily manufactured using wafer fabrication techniques that Motorola has used for several years to manufacture highly successful 8-bit microcontrollers.

HDTMOS devices are designed for use in low voltage, high speed switching applications where power efficiency is important. Typical applications are dc-dc converters and power management in portable and battery powered products such as computers, printers, cellular and cordless phones. They can also be used for low voltage motor controls in mass storage products such as disk drives and tape drives.

### High Power

V(BR)DSS (V)	RDS(on) @ VGS			ID (A)	Motorola Part Number	Package Type
	10 V (mΩ)	5 V (mΩ)	2.7 V (mΩ)			
60	45	—	—	20	<i>MTD20N06HD</i> <sup>(4)</sup>	DPAK
	—	45	—	20	<i>MTD20N06HDL</i> <sup>(4)</sup>	DPAK
	—	150	—	15	<i>MTD20P06HDL</i> <sup>(4)</sup>	DPAK
	10	—	—	75	<i>MTB75N06HD</i> <sup>(4)</sup>	D <sup>2</sup> PAK
	14	—	—	60	<i>MTB60N06HD</i> <sup>(4)</sup>	D <sup>2</sup> PAK
	10	—	—	75	<i>MTP75N06HD</i>	TO-220
50	14	—	—	60	<i>MTP60N06HD</i>	TO-220
	9.50	—	—	75	<i>MTP75N05HD</i>	TO-220
30	9.50	—	—	75	<i>MTB75N05HD</i> <sup>(4)</sup>	D <sup>2</sup> PAK
	—	35	—	20	<i>MTD20N03HDL</i> <sup>(4)</sup>	DPAK
	—	99	—	19	<i>MTD20P03HDL</i> <sup>(4)</sup>	DPAK
	6.0	7.0	—	75	<i>MTB75N03HDL</i> <sup>(4)</sup>	D <sup>2</sup> PAK
	—	30	—	50	<i>MTB50P03HDL</i> <sup>(4)</sup>	D <sup>2</sup> PAK
	6.0	7.0	—	75	<i>MTP75N03HDL</i>	TO-220
—	30	—	50	<i>MTP50P03HDL</i>	TO-220	

### SOIC

V(BR)DSS (V)	RDS(on) @ VGS			ID (A)	Motorola Part Number <sup>(5)</sup>	Package Type
	10 V (mΩ)	4.5 V (mΩ)	2.7 V (mΩ)			
50	300	500	—	1.0	<i>MMDF1N05E</i>	SO-8
30	40	50	—	5.0	<i>MMSF5N03HD</i>	SO-8
	60	75	—	2.8	<i>MMDF3N03HD</i>	SO-8
	200	300	—	2.0	<i>MMDF2P03HD</i>	SO-8
	70/200 <sup>(11)</sup>	90/300 <sup>(11)</sup>	—	2.0	<i>MMDF2C03HD</i>	SO-8
20	45	50	—	5.0	<i>MMSF5N02HD</i>	SO-8
	75	95	—	3.0	<i>MMSF3P02HD</i>	SO-8
	90	100	—	3.0	<i>MMDF3N02HD</i>	SO-8
	250	400	—	2.0	<i>MMDF2P02E</i>	SO-8
	100	200	—	2.0	<i>MMDF2N02E</i>	SO-8
	100/200 <sup>(11)</sup>	200/350 <sup>(11)</sup>	—	2.0	<i>MMDF2C02E</i>	SO-8
12	—	—	45	6.0	<i>MMSF6N01HD</i>	SO-8
	—	80	90	4.0	<i>MMSF4P01HD</i>	SO-8
	—	—	100	4.0	<i>MMDF4N01HD</i>	SO-8
	—	180	220	2.0	<i>MMDF2P01HD</i>	SO-8
	—	—	100/200 <sup>(11)</sup>	2.0	<i>MMDF2C01HD</i>	SO-8

<sup>(4)</sup> Available in tape and reel — add T4 suffix to part number.

<sup>(5)</sup> Available in tape and reel only — R1 suffix = 500/reel, R2 suffix = 2500/reel.

<sup>(11)</sup> N-Channel/P-Channel RDS(on)

Devices listed in bold, italic are Motorola preferred devices.

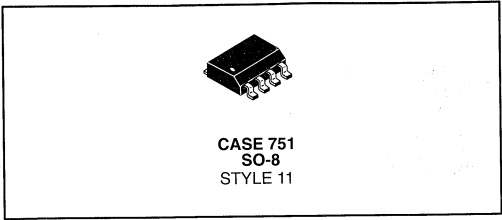

# N-Channel

## SO-8 (MiniMOS™) Surface Mount Products

MiniMOS devices are an advanced series of power MOSFETs which utilize Motorola's High Cell Density HDTMOS process. These miniature surface mount MOSFETs feature ultra low  $R_{DS(on)}$  and true logic level performance.

MiniMOS devices are designed for use in low voltage, high speed switching applications where power efficiency is important. Typical applications are dc-dc converters and power management in portable and battery powered products such as computers, printers, cellular and cordless phones. They can also be used for low voltage motor controls in mass storage products such as disk drives and tape drives.

- Ultra Low  $R_{DS(on)}$  Provides Higher Efficiency and Extends Battery Life
- Logic Level Gate Drive — Can Be Driven by Logic ICs
- Miniature SO-8 Surface Mount Package — Saves Board Space
- Diode Is Characterized for Use In Bridge Circuits
- Diode Exhibits High Speed, with Soft Recovery
- $I_{DSS}$  and  $V_{DS(on)}$  Specified at Elevated Temperature
- Avalanche Energy Specified

Table 1. SO-8 Products — N-Channel

V(BR)DSS (V)	$R_{DS(on)}$ @ $V_{GS}$			$I_D$ (A)	Motorola Part Number <sup>(5)</sup>	Package Type	$P_D$ <sup>(3)</sup> (Watts) Max
	10 V (m $\Omega$ )	4.5 V (m $\Omega$ )	2.7 V (m $\Omega$ )				
50	180	200	—	1	<b><i>MMDF1N05E</i></b>	SO-8	1.5
30	40	50	—	5	<b><i>MMSF5N03HD</i></b>	SO-8	1.5
	60	75	—	2.8	<b><i>MMDF3N03HD</i></b>	SO-8	1.5
	70/200(11)	90/300	—	2	<b><i>MMDF2C03HD</i></b>	SO-8	1.5
20	45	50	—	5	<b><i>MMSF5N02HD</i></b>	SO-8	1.5
	90	100	—	3	<b><i>MMDF3N02HD</i></b>	SO-8	1.5
	100	200	—	2	<b><i>MMDF2N02E</i></b>	SO-8	1.5
	100/200(11)	200/350(11)	—	2	<b><i>MMDF2C02E</i></b>	SO-8	1.5
12	—	—	45	6	<b><i>MMSF6N01HD</i></b>	SO-8	1.5
	—	—	100	4	<b><i>MMDF4N01HD</i></b>	SO-8	1.5
	—	—	100/200(11)	2	<b><i>MMDF2C01HD</i></b>	SO-8	1.5

<sup>(3)</sup> Power rating when mounted on an FR-4 glass epoxy printed circuit board with the minimum recommended footprint.

<sup>(5)</sup> Available in tape and reel only — R1 suffix = 500/reel, R2 suffix = 2500/reel.

<sup>(11)</sup> N-Channel/P-Channel  $R_{DS(on)}$

Devices listed in bold, italic are Motorola preferred devices.

5

**N-Channel** (continued)

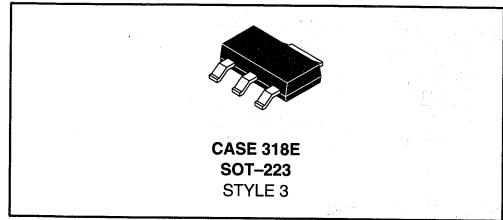

**N-Channel**

**SOT-223 Medium Power MOSFETs Surface Mount Products**

Table 2. SOT-223 Medium Power TMOS FETs — N-Channel

$V_{(BR)DSS}$ (Volts) Min	$R_{DS(on)}$ (Ohms) @ Max	$I_D$ (Amps)	Device (12)	$I_D$ (cont) Amps	$P_D^{(1)}$ (Watts) Max	Applications
100	0.30	0.5	<b><i>MMFT1N10E</i></b>	1	0.8(3)	dc-dc Converters Power Supplies Motor Controls, Disk Drives
60	0.18	0.75	<b><i>MMFT3055EL</i></b>	1.5		
	0.15	0.85	<b><i>MMFT3055E</i></b>	1.7		
20	0.15	1	<b><i>MMFT2N02EL</i></b>	2		

(1)  $T_C = 25^\circ C$

(3) Power rating when mounted on an FR-4 glass epoxy printed circuit board with the minimum recommended footprint.

(12) Available in tape and reel only — T1 suffix = 1000/reel, T3 suffix = 4000/reel.

Devices listed in bold, italic are Motorola preferred devices.



N-Channel (continued)

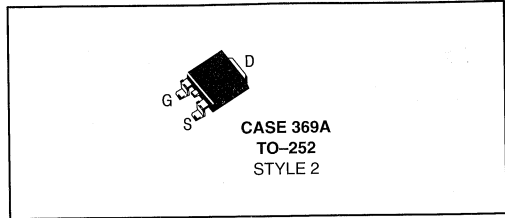

N-Channel

DPAK Surface Mount Products

Table 3. DPAK — N-Channel

$V_{(BR)DSS}$ (Volts) Min	$R_{DS(on)}$ (Ohms) Max	@	$I_D$ (Amps)	Device <sup>(4)</sup>	$I_D$ (cont) Amps	$P_D^{(1)}$ (Watts) Max
800	12		0.5	<i>MTD1N80E</i>	1	1.75 <sup>(3)</sup>
600	8		0.5	<i>MTD1N60E</i>	1	
500	5		0.5	<i>MTD1N50E</i>	1	
	3.60		1	<i>MTD2N50E</i>	2	
400	3.50		1	<i>MTD2N40E</i>	2	
250	1.40		1.5	<i>MTD3N25E</i>	3	
	1		2.5	<i>MTD5N25E</i>	5	
200	1.20		2	<i>MTD4N20E</i>	4	
	0.70		2	<i>MTD4N20</i>	4	
150	0.30		3	MTD6N15	6	
100	0.40		3	<i>MTD6N10E</i>	6	
	0.25		4.5	<i>MTD9N10E</i>	9	
60	0.18		6	<i>MTD3055EL</i> <sup>(2)</sup>	12	
	0.15		4	<i>MTD3055E</i>	8	
	0.12		4	<i>MTD8N06E</i>	8	
	0.045		10	<i>MTD20N06HD</i>	20	
	0.045		10	<i>MTD20N06HDL</i> <sup>(2)</sup>	20	
50	0.10		5	<i>MTD10N05E</i>	10	
30	0.035		10	<i>MTD20N03HDL</i> <sup>(2)</sup>	20	

(1)  $T_C = 25^\circ\text{C}$

(2) Indicates logic level

(3) Power rating when mounted on an FR-4 glass epoxy printed circuit board with the minimum recommended footprint.

(4) Available in tape and reel — add T4 suffix to part number.

Devices listed in bold, italic are Motorola preferred devices.

5

## N-Channel (continued)

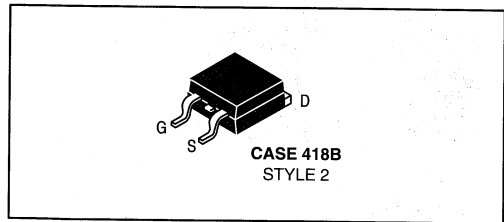

## N-Channel

### D2PAK Surface Mount Products

Table 4. D2PAK — N-Channel

V <sub>(BR)DSS</sub> (Volts) Min	R <sub>DS(on)</sub> (Ohms) Max	@	I <sub>D</sub> (Amps)	Device (4)	I <sub>D</sub> (cont) Amps	P <sub>D</sub> (1) (Watts) Max
1200	5		1.5	<i>MTB3N120E</i>	3	2.5 <sup>(3)</sup>
1000	9		0.5	<i>MTB1N100E</i>	1	
	4		1.5	<i>MTB3N100E</i>	3	
800	3		2	<i>MTB4N80E</i>	4	
600	1.20		3	<i>MTB6N60E</i>	6	
500	0.80		4	<i>MTB8N50E</i>	8	
400	0.55		5	<i>MTB10N40E</i>	10	
200	0.16		10	<i>MTB20N20E</i>	20	
100	0.060		16.5	<i>MTB33N10E</i>	33	
60	0.12		7.5	<i>MTB15N06E</i>	15	
	0.05		15	<i>MTB30N06EL</i> <sup>(2)</sup>	30	
	0.04		18	<i>MTB36N06E</i>	36	
	0.028		25	<i>MTB50N06EL</i> <sup>(2)</sup>	50	
	0.025		25	<i>MTB50N06E</i>	50	
	0.014		30	<i>MTB60N06HD</i>	60	
	0.01		37.5	<i>MTB75N06HD</i>	75	
50	0.0095		37.5	<i>MTB75N05HD</i>	75	
30	0.007		37.5	<i>MTB75N03HDL</i> <sup>(2)</sup>	75	

(1) T<sub>C</sub> = 25°C

(2) Indicates logic level

(3) Power rating when mounted on an FR-4 glass epoxy printed circuit board with the minimum recommended footprint.

(4) Available in tape and reel — add T4 suffix to part number.

5

Devices listed in bold, italic are Motorola preferred devices.

N-Channel (continued)

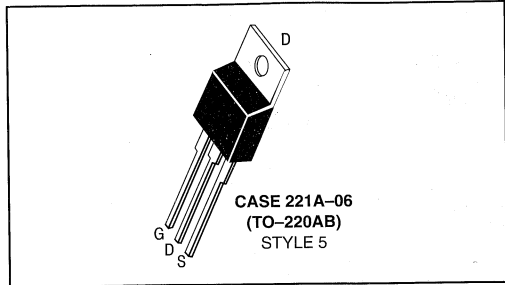

N-Channel

TO-220AB

Table 5. TO-220AB — N-Channel

V <sub>(BR)DSS</sub> (Volts) Min	R <sub>DS(on)</sub> (Ohms) Max	@	I <sub>D</sub> (Amps)	Device	I <sub>D</sub> (cont) (Amps)	P <sub>D</sub> (1) (Watts) Max
1200	5		1.5	<i>MTP3N120E</i>	1.5	75
1000	9		0.5	<i>MTP1N100E</i>	1	125
	4.0		1.5	<i>MTP3N100E</i>	3	
800	3		2	<i>MTP4N80E</i>	4	50
600	8		0.5	<i>MTP1N60E</i>	1	
	3.80		1	<i>MTP2N60E</i>	2	
	2.20		1.5	<i>MTP3N60E</i>	3	
	1.20		3	<i>MTP6N60E</i>	6	
500	5		0.5	<i>MTP1N50E</i>	1	50
	3.60		1	<i>MTP2N50E</i>	2	75
	3		1.5	IRF820	2.5	40
	3		1.5	<i>MTP3N50E</i>	3	50
	1.50		1.5	IRF830	4.5	75
	1.50		2	<i>MTP4N50E</i>	4	125
	0.85		4	IRF840	8	
	0.80		4	<i>MTP8N50E</i>	8	
400	3.50		1	<i>MTP2N40E</i>	2	50
	1.80		1.5	IRF720	3	40
	1.80		2	<i>MTP4N40E</i>	4	50
	1		3	IRF730	4.5	75
	1		2.5	<i>MTP5N40E</i>	5	125
	0.55		5	IRF740	10	
	0.55		5	<i>MTP10N40E</i>	10	
250	1.4		1	<i>MTP3N25E</i>	3	40
200	1.80		1	MTP2N20	2	50
	1.50		1.3	IRF610	2.5	20
	0.80		1.3	IRF620	5	40
	0.70		3.5	MTP7N20	7	75
	0.40		2	IRF630	9	

(1) T<sub>C</sub> = 25°C

Devices listed in bold, italic are Motorola preferred devices.

5

## N-Channel (continued)

Table 5. TO-220AB — N-Channel (continued)

V <sub>(BR)DSS</sub> (Volts) Min	R <sub>DS(on)</sub> (Ohms) Max	@	I <sub>D</sub> (Amps)	Device	I <sub>D</sub> (cont) Amps	P <sub>D</sub> <sup>(1)</sup> (Watts) Max
200	0.40		4	MTP8N20	8	
	0.35		6	MTP12N20	12	100
	0.18		10	IRF640	18	125
	0.16		10	<b>MTP20N20E</b>	20	
150	0.30		5	MTP10N15	10	75
	0.25		7.5	MTP15N15	15	100
100	0.80		3	MTP6N10	6	50
	0.60		2	IRF510	4	20
	0.27		5	IRF520	8	40
	0.25		5	<b>MTP10N10E</b>	10	75
	0.16		7	IRF530	14	
	0.16		6	<b>MTP12N10E</b>	12	
	0.077		14	IRF540	28	125
	0.060		16.5	<b>MTP33N10E</b>	33	150
60	0.15		6	<b>MTP3055E</b>	12	40
	0.12		7.5	<b>MTP15N06E</b>	15	75
	0.085		10	MTP20N06	20	
	0.05		15	IRFZ30	30	
	0.04		18	<b>MTP36N06E</b>	36	150
	0.028		25	IRFZ44	50	
	0.025		25	<b>MTP50N06E</b>	50	
	0.014		30	<b>MTP60N06HD</b>	60	
0.01		37.5	<b>MTP75N06HD</b>	75	150	
50	0.12		6	<b>BUZ71A</b>	12	40
	0.10		6	BUZ71	12	
	0.10		7.5	<b>MTP15N05E</b>	15	
	0.10		7.5	IRFZ20	15	
	0.06		15	BUZ11A	25	75
	0.04		15	BUZ11	30	
	0.028		25	<b>MTP50N05E</b>	50	150
	0.0095		37.5	<b>MTP75N05HD</b>	75	
30	0.007		37.5	<b>MTP75N03HDL</b> <sup>(2)</sup>	75	

(1) T<sub>C</sub> = 25°C

(2) Indicates logic level

5

Devices listed in bold, italic are Motorola preferred devices.

N-Channel (continued)

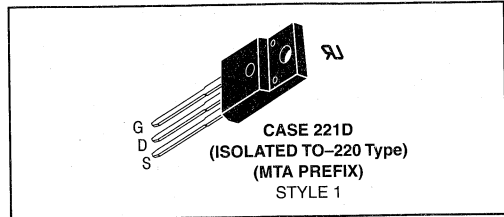

N-Channel

Isolated TO-220

Table 6. Fully Isolated TO-220 — N-Channel

$V_{(BR)DSS}$ (Volts) Min	$R_{DS(on)}$ (Ohms) Max	@	$I_D$ (Amps)	Device	$I_D$ (cont) Amps	$P_D^{(1)}$ (Watts) Max
600	3.80		1	<i>MTA1N60E</i>	1	40
	2.20		1.5	<i>MTA2N60E</i>	2	
	1.20		3	<i>MTA4N60E</i>	4	50
500	1.50		2	<i>MTA4N50E</i>	4	40
	0.80		4	<i>MTA5N50E</i>	5	50
400	1		2.5	<i>MTA4N40E</i>	4	40
	0.55		3	<i>MTA6N40E</i>	6	50
100	0.25		4	<i>MTA8N10E</i>	8	35
60	0.15		6	<i>MTA3055E</i>	9	30
	0.025		15	<i>MTA30N06E</i>	30	50

(1)  $T_C = 25^\circ\text{C}$

Indicates UL Recognition — File #E69369

5

Devices listed in bold, italic are Motorola preferred devices.

## N-Channel (continued)



## N-Channel

### TO-247 Isolated Mounting Hole

The Motorola portfolio of TO-247 devices has new on-resistance specifications on many industry standard devices with RDS(on) reductions up to 25%.

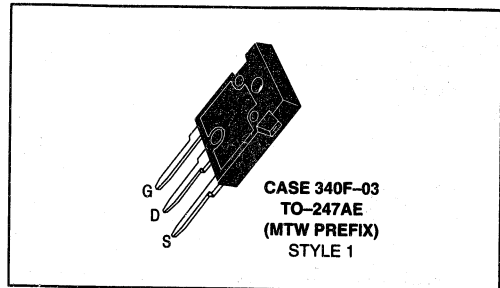

Table 7. TO-247 — N-Channel

V <sub>(BR)DSS</sub> (Volts) Min	R <sub>DS(on)</sub> (Ohms) Max	@	I <sub>D</sub> (Amps)	Device	I <sub>D</sub> (cont) Amps	P <sub>D</sub> (1) (Watts) Max
1000	1.50		3	<i>MTW6N100E</i>	6	180
	1.30		5	<i>MTW10N100E</i>	10	250
800	3		2	<i>MTW4N80E</i>	4	150
	1		3.5	<i>MTW7N80E</i>	7	180
600	1.20		3	<i>MTW6N60E</i>	6	250
	0.50		4	<i>MTW8N60E</i>	8	180
500	0.60		4	<i>MTW8N50E</i>		14
	0.32		7	<i>MTW14N50E</i>	180	
	0.24		10	<i>MTW20N50E</i>	20	
400	0.55		5	<i>MTW10N40E</i>	10	150
	0.30		8	<i>MTW16N40E</i>	16	180
	0.16		12	<i>MTW24N40E</i>	24	250
250	0.28		7.5	<i>MTW15N25E</i>	15	150
	0.14		11.5	<i>MTW23N25E</i>	23	180
	0.10		16	<i>MTW32N25E</i>	32	250
200	0.15		10	<i>MTW20N20E</i>	20	150
	0.075		16	<i>MTW32N20E</i>	32	180
150	0.095		13	<i>MTW26N15E</i>	26	150
	0.065		17.5	<i>MTW35N15E</i>	35	180
100	0.058		16.5	<i>MTW33N10E</i>	33	150
	0.035		22.5	<i>MTW45N10E</i>	45	180
50	0.014		27	<i>MTW54N05E</i>	54	210

(1) T<sub>C</sub> = 25°C

5

Devices listed in bold, italic are Motorola preferred devices.

## N-Channel (continued)

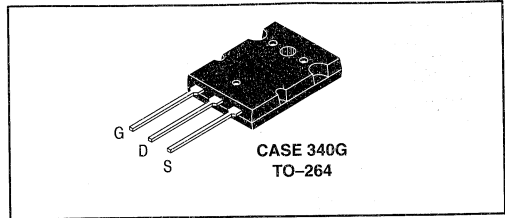

## N-Channel

### TO-264 High Power Products (formerly TO-3PBL)

The TO-264 package is the newest addition to the Motorola portfolio of high power packages. This package is capable of a power dissipation of 300 Watts and it achieves a low on-resistance with a single die. Lead spacing is compatible to the TO-247 package.

Table 8. TO-264 High Power Products — N-Channel

$V_{(BR)DSS}$ (Volts) Min	$R_{DS(on)}$ (Ohms) Max	@	$I_D$ (Amps)	Device	$I_D$ (cont) Amps	$P_D^{(1)}$ (Watts) Max
1000	1.30		5	<i>MTY10N100E</i>	10	300
600	0.50		12.5	<i>MTY25N60E</i>	25	
500	0.14		15	<i>MTY30N50E</i>	30	
200	0.028		27.5	<i>MTY55N20E</i>	55	
100	0.01		50	<i>MTY100N10E</i>	100	

(1)  $T_C = 25^\circ\text{C}$

5

Devices listed in bold, italic are Motorola preferred devices.

**N-Channel** (continued)

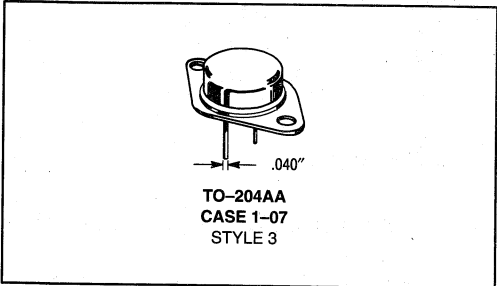

**N-Channel**

**TO-204AA (TO-3)  
Metal Packages**

**Table 9. TO-204AA — N-Channel**

V(BR)DSS (Volts) Min	RDS(on) (Ohms) Max	@	ID (Amps)	Device	ID (cont) Amps	PD(1) (Watts) Max
800	1.50		3	BUZ84A	6	125
500	0.40		3.5	IRF450	13	150
400	0.30		7.5	MTM15N40E	15	250
200	0.40		5	IRF230	9	75
	0.18		10	IRF240	18	125
	0.085		16	IRF250	30	
100	0.16		8	IRF130	14	75
	0.085		15	IRF140	27	100
	0.055		20	IRF150	40	

(1) TC = 25°C

**5**



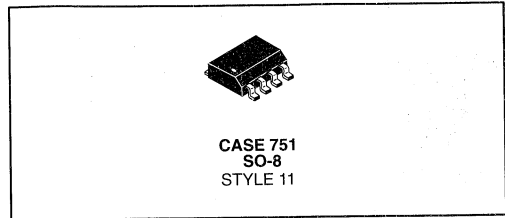

## P-Channel

### SO-8 (MiniMOS) Surface Mount Products

#### Multiple Chip TMOS Products in SOIC Surface Mount Packages

MiniMOS devices are an advanced series of power MOSFETs which utilize Motorola's High Cell Density HDTMOS process. These miniature surface mount MOSFETs feature ultra low  $R_{DS(on)}$  and true logic level performance.

MiniMOS devices are designed for use in low voltage, high speed switching applications where power efficiency is important. Typical applications are dc-dc converters and power management in portable and battery powered products such as computers, printers, cellular and cordless phones. They can also be used for low voltage motor controls in mass storage products such as disk drives and tape drives.

Table 1. SO-8 Products — P-Channel

$V_{(BR)DSS}$ (V)	$R_{DS(on)}$ @ $V_{GS}$			$I_D$ (A)	Motorola (5) Part Number	Package Type	$P_D^{(3)}$ (Watts) Max
	10 V (m $\Omega$ )	4.5 V (m $\Omega$ )	2.7 V (m $\Omega$ )				
30	200	300	—	2	<b><i>MMDF2P03HD</i></b>	SO-8	1.5
20	75	95	—	3	<b><i>MMSF3P02HD</i></b>	SO-8	1.5
	250	400	—	2	<b><i>MMDF2P02E</i></b>	SO-8	1.5
12	—	80	90	4	<b><i>MMSF4P01HD</i></b>	SO-8	1.5
	—	180	220	2	<b><i>MMDF2P01HD</i></b>	SO-8	1.5

(3) Power rating when mounted on an FR-4 glass epoxy printed circuit board with the minimum recommended footprint.

(5) Available in tape and reel only — R1 suffix = 500/reel, R2 suffix = 2500/reel.

5

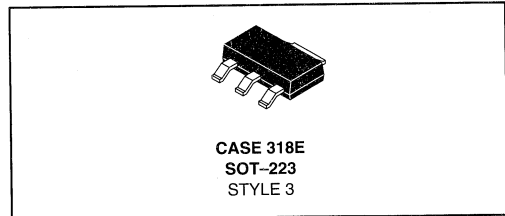

### SOT-223 Medium Power MOSFETs Surface Mount Products

Table 2. SOT-223 Medium Power TMOS FETs — P-Channel

$V_{(BR)DSS}$ (Volts) Min	$R_{DS(on)}$ (Ohms) @ Max	$I_D$ (Amps)	Device (12)	$I_D$ (cont) Amps	$P_D^{(1)}$ (Watts) Max	Application
60	0.30	0.6	<b><i>MMFT2955E</i></b>	1.2	0.8 <sup>(3)</sup>	dc-dc Converters Power Supplies Motor Controls, Disk Drives

(1)  $T_C = 25^\circ\text{C}$

(3) Power rating when mounted on an FR-4 glass epoxy printed circuit board with the minimum recommended footprint.

(12) Available in tape and reel only — T1 suffix = 1000/reel, T3 suffix = 4000/reel.

Devices listed in bold, italic are Motorola preferred devices.

P-Channel (continued)

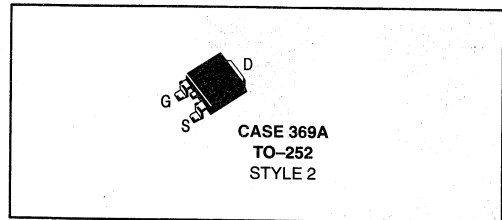

P-Channel

DPAK Surface Mount Products

Table 3. DPAK — P-Channel

V(BR)DSS (Volts) Min	RDS(on) (Ohms) Max	@	ID (Amps)	Device (4)	ID (cont) Amps	PD(1) (Watts) Max
100	0.66		3	<b>MTD6P10E</b>	6	1.75(3)
60	0.55		2.5	<b>MTD5P06E</b>	5	
	0.30		6	<b>MTD2955E</b>	12	
	0.15		10	<b>MTD20P06HDL(2)</b>	20	
30	0.099		10	<b>MTD20P03HDL(2)</b>	19	

(1)  $T_C = 25^\circ\text{C}$

(2) Indicates logic level

(3) Power rating when mounted on an FR-4 glass epoxy printed circuit board with the minimum recommended footprint.

(4) Available in tape and reel — add T4 suffix to part number.

5

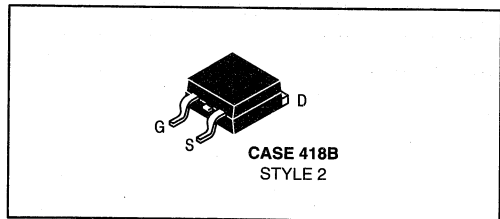

D2PAK Surface Mount Products

Table 4. D2PAK — P-Channel

V(BR)DSS (Volts) Min	RDS(on) (Ohms) Max	@	ID (Amps)	Device (4)	ID (cont) Amps	PD(1) (Watts) Max
500	6		1	<b>MTB2P50E</b>	2	2.5(3)
60	0.12		11.5	<b>MTB23P06E</b>	23	
30	0.03		25	<b>MTB50P03HDL(2)</b>	50	

(1)  $T_C = 25^\circ\text{C}$

(2) Indicates logic level

(3) Power rating when mounted on an FR-4 glass epoxy printed circuit board with the minimum recommended footprint.

(4) Available in tape and reel — add T4 suffix to part number.

Devices listed in bold, italic are Motorola preferred devices.

**P-Channel** (continued)

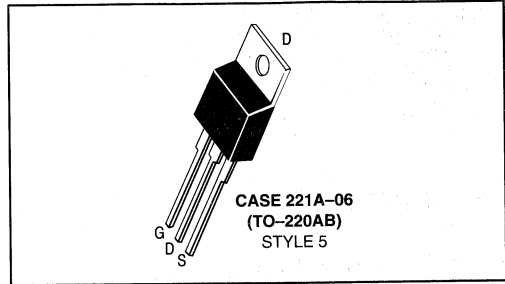

**P-Channel**

**TO-220AB**

Table 5. TO-220AB — P-Channel

V <sub>(BR)DSS</sub> (Volts) Min	R <sub>DS(on)</sub> (Ohms) Max	@	I <sub>D</sub> (Amps)	Device	I <sub>D</sub> (cont) Amps	P <sub>D</sub> <sup>(1)</sup> (Watts) Max
500	6		1	<i>MTP2P50E</i>	2	75
250	3		2.5	<i>MTP5P25</i>	5	
200	1		3	<i>MTP6P20E</i>	6	
			4	<i>MTP8P20</i>	8	
100	0.40		4	MTP8P10	8	60
	0.30		6	<i>MTP12P10</i>	12	88
60	0.60		3.5	MTP7P06	7	75
	0.30		6	<i>MTP2955E</i>	12	
	0.30		6	MTP12P06	12	
	0.12		11.5	<i>MTP23P06</i>	23	125
30	0.03		25	<i>MTP50P03HDL</i> <sup>(2)</sup>	50	150

<sup>(1)</sup> T<sub>C</sub> = 25°C

<sup>(2)</sup> Indicates logic level

**5**

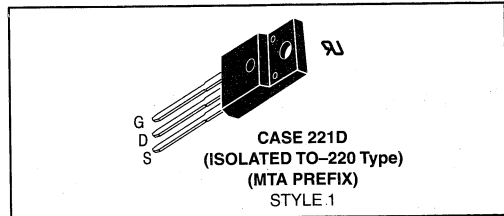

**Isolated TO-220**

Table 6. Fully Isolated TO-220 — P-Channel

V <sub>(BR)DSS</sub> (Volts) Min	R <sub>DS(on)</sub> (Ohms) Max	@	I <sub>D</sub> (Amps)	Device	I <sub>D</sub> (cont) Amps	P <sub>D</sub> <sup>(1)</sup> (Watts) Max
60	0.30		6	<i>MTA2955E</i>	8	40

<sup>(1)</sup> T<sub>C</sub> = 25°C

Indicates UL Recognition — File #E69369

Devices listed in bold, italic are Motorola preferred devices.

P-Channel (continued)



P-Channel

TO-247 Isolated Mounting Hole

The Motorola portfolio of TO-247 devices has new on-resistance specifications on many industry standard devices with  $R_{DS(on)}$  reductions up to 25%.

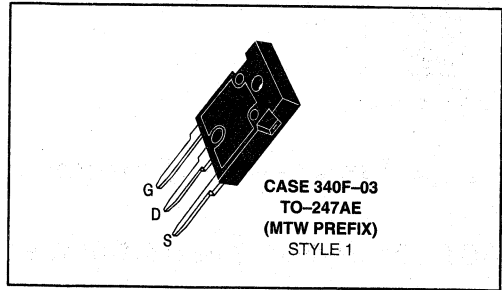
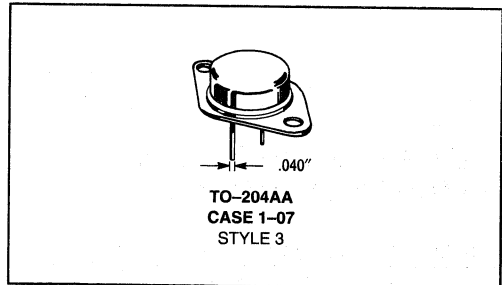

Table 7. TO-247 Isolated Mounting Hole — P-Channel

$V_{(BR)DSS}$ (Volts) Min	$R_{DS(on)}$ (Ohms) Max	@	$I_D$ (Amps)	Device	$I_D$ (cont) Amps	$P_D^{(1)}$ (Watts) Max
200	0.50		7	<i>MTW14P20</i>	14	208
100	0.15		10	<i>MTW20P10</i>	20	180

(1)  $T_C = 25^\circ C$

TO-204AA (TO-3)  
Metal Packages



5

Table 8. TO-204AA — P-Channel

$V_{(BR)DSS}$ (Volts) Min	$R_{DS(on)}$ (Ohms) Max	@	$I_D$ (Amps)	Device	$I_D$ (cont) Amps	$P_D^{(1)}$ (Watts) Max
100	0.30		6	MTM12P10	12	75

(1)  $T_C = 25^\circ C$

Devices listed in bold, italic are Motorola preferred devices.

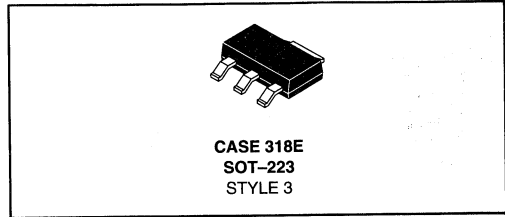

## Logic Level — N-Channel

### SOT-223 Medium Power MOSFETs Surface Mount Products

Table 1. SOT-223 Medium Power TMOS FETs — Logic Level

V(BR)DSS (Volts) Min	RDS(on) (Ohms) @ Max	I <sub>D</sub> (Amps)	Device (12)	I <sub>D</sub> (cont) Amps	P <sub>D</sub> (1) (Watts) Max	Application
60	0.18	0.75	<b>MMFT3055EL</b>	1.5	0.8(3)	dc-dc Converters Power Supplies Motor Controls, Disk Drives
20	0.15	1	<b>MMFT2N02EL</b>	2		

(1) T<sub>C</sub> = 25°C

(3) Power rating when mounted on an FR-4 glass epoxy printed circuit board with the minimum recommended footprint.

(12) Available in tape and reel only — T1 suffix = 1000/reel, T3 suffix = 4000/reel.

5

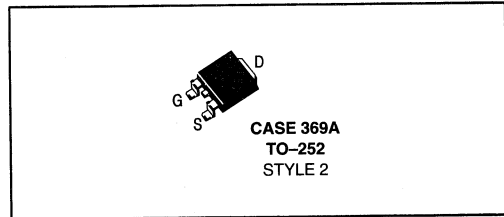

## DPAK — N and P-Channel Surface Mount Products

Table 2. DPAK — Logic Level

V(BR)DSS (Volts) Min	RDS(on) (Ohms) Max	@ I <sub>D</sub> (Amps)	Device (4)	I <sub>D</sub> (cont) Amps	P <sub>D</sub> (1) (Watts) Max
60	0.18	6	<b>MTD3055EL</b>	12	1.75(3)
	0.15	10	<b>MTD20P06HDL</b>	20	
	0.045	10	<b>MTD20N06HDL</b>	20	
30	0.035	10	<b>MTD20N03HDL</b>	20	

(1) T<sub>C</sub> = 25°C

(3) Power rating when mounted on an FR-4 glass epoxy printed circuit board with the minimum recommended footprint.

(4) Available in tape and reel — add T4 suffix to part number.

Devices listed in bold, italic are Motorola preferred devices.

## Logic Level (continued)

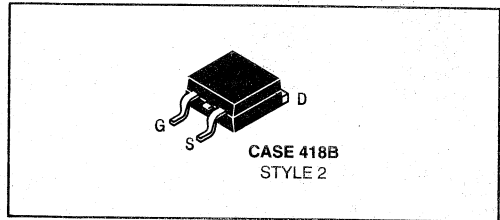

## Logic Level

### D2PAK — N and P-Channel Surface Mount Products

Table 3. D2PAK — Logic Level

$V_{(BR)DSS}$ (Volts) Min	$R_{DS(on)}$ (Ohms) Max	@	$I_D$ (Amps)	Device (4)	$I_D$ (cont) Amps	$P_D^{(1)}$ (Watts) Max
60	0.05		15	<b><i>MTB30N06EL</i></b>	30	2.5(3)
	0.028		25	<b><i>MTB50N06EL</i></b>	50	
30	0.025		25	<b><i>MTB50P03HDL</i></b>	50	
	0.007		37.5	<b><i>MTB75N03HDL</i></b>	75	

(1)  $T_C = 25^\circ\text{C}$

(3) Power rating when mounted on an FR-4 glass epoxy printed circuit board with the minimum recommended footprint.

(4) Available in tape and reel — add T4 suffix to part number.

5

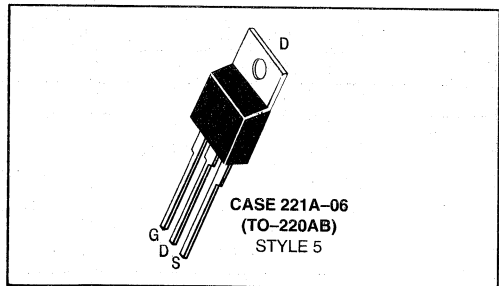

### TO-220AB — N and P-Channel

Table 4. TO-220AB — Logic Level

$V_{(BR)DSS}$ (Volts) Min	$R_{DS(on)}$ (Ohms) Max	@	$I_D$ (Amps)	Device	$I_D$ (cont) Amps	$P_D^{(1)}$ (Watts) Max
30	0.03		25	<b><i>MTP50P03HDL</i></b>	50	150
	0.007		37.5	<b><i>MTP75N03HDL</i></b>	75	

(1)  $T_C = 25^\circ\text{C}$

Devices listed in bold, italic are Motorola preferred devices.



# Logic Level Power MOSFETs

## N and P-Channel

Logic level MOSFETs are fully enhanced with 5 volts applied to the gate.

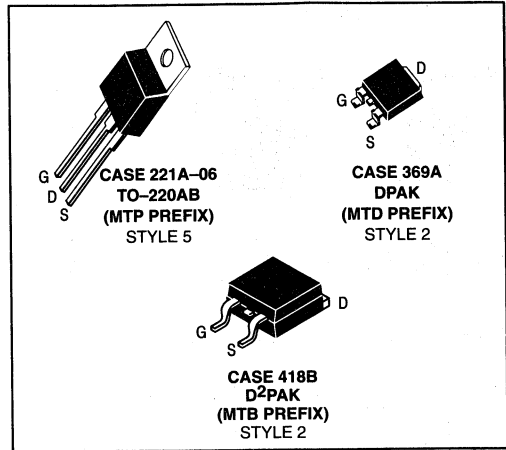

Table 1. Logic Level Power MOSFETs

$V_{(BR)DSS}$ (Volts) Min	$R_{DS(on)}$ (Ohms) Max	@	$I_D$ (Amps)	Device <sup>(4)</sup>	$I_D$ (cont) Amps	$P_D^{(1)}$ (Watts) Max	Package
60	0.18		6	<b><i>MTD3055EL</i></b>	10	1.75 <sup>(3)</sup>	DPAK
	0.18		6	<b><i>MTP3055EL</i></b>	12	40	TO-220AB
	0.15		10	<b><i>MTD20P06HDL</i></b>	20	1.75 <sup>(3)</sup>	DPAK
	0.05		15	<b><i>MTP30N06EL</i></b>	30	75	TO-220AB
	0.045		10	<b><i>MTD20N06HDL</i></b>	20	1.75 <sup>(3)</sup>	DPAK
	0.028		25	<b><i>MTP50N06EL</i></b>	50	150	TO-220AB
	0.028		25	<b><i>MTB50N06EL</i></b>	50	150 <sup>(3)</sup>	D <sup>2</sup> PAK
50	0.10		7.5	<b><i>MTP15N05EL</i></b>	15	75	TO-220AB
30	0.09		10	<b><i>MTD20P03HDL</i></b>	20	1.75 <sup>(3)</sup>	DPAK
	0.085		8	<b><i>MTD20P03HDL</i></b>	20	1.75 <sup>(3)</sup>	DPAK
	0.040		10	<b><i>MTD20N03HDL</i></b>	20	1.75 <sup>(3)</sup>	DPAK
	0.035		10	<b><i>MTD20N03HDL</i></b>	20	1.75 <sup>(3)</sup>	DPAK
	0.03		25	<b><i>MTB50P03HDL</i></b>	50	2.5 <sup>(3)</sup>	D <sup>2</sup> PAK
	0.03		25	<b><i>MTP50P03HDL</i></b>	50	150	TO-220AB
	0.025		25	<b><i>MTB50P03HDL</i></b>	50	2.5 <sup>(3)</sup>	D <sup>2</sup> PAK
	0.025		25	<b><i>MTP50P03HDL</i></b>	50	150	TO-220AB
	0.007		37.5	<b><i>MTB75N03HDL</i></b>	75	2.5 <sup>(3)</sup>	D <sup>2</sup> PAK
	0.007		37.5	<b><i>MTB75N03HDL</i></b>	75	2.5 <sup>(3)</sup>	D <sup>2</sup> PAK
	0.007		37.5	<b><i>MTP75N03HDL</i></b>	75	150	TO-220AB

(1)  $T_C = 25^\circ\text{C}$

(3) Power rating when mounted on an FR-4 glass epoxy printed circuit board with the minimum recommended footprint.

(4) DPAK and D<sup>2</sup>PAK packages available in tape and reel — add T4 suffix to part number.

Devices listed in bold, italic are Motorola preferred devices.



# ICePAK Multiple Chip Packages

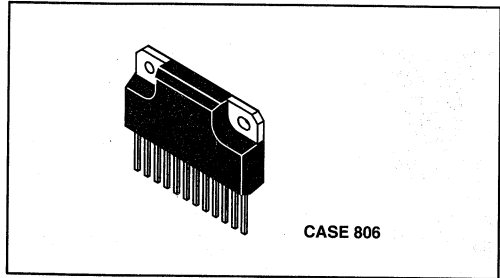
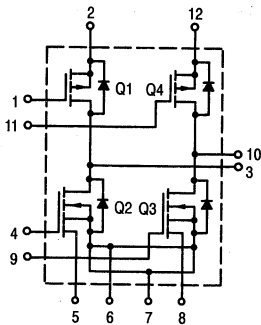

Table 1. ICePAK™ Insulated Products

V(BR)DSS (Volts) Min	P-Channel R <sub>DS(on)</sub> (Ohms) Max	N-Channel R <sub>DS(on)</sub> (Ohms) Max	Part Number	I <sub>D</sub> (cont) Amps	P <sub>D</sub> (1) (Watts) Max	Description
100	0.4	0.15	<b>MPM3002</b>	8	62.5	H-Bridge with Current Sensing
60	0.28		<b>MPM3003</b>	10		3-Phase Bridge with Complementary Outputs
			<b>MPM3004</b>			H-Bridge
60	0.15	0.04	<b>MPM3008</b>	16	50	H-Bridge with Schottky Rectifiers
		0.15	<b>MPM3010</b>	12		H-Bridge with Current Sensing
		0.04	<b>MPM3017</b>	25		62.5

(1) T<sub>C</sub> = 25°C

## Multiple Chip Power Module Device Circuits



**H-Bridge with Current Sensing**  
**MPM3002/MPM3010**

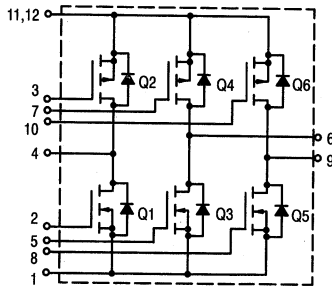

**Three-Phase Bridge with Complementary Outputs**  
**MPM3003**

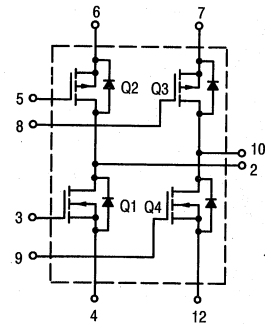

**H-Bridge**  
**MPM3004**

5

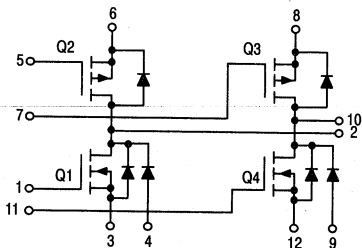

**Complementary H-Bridge with Schottky Clamps**  
**MPM3008**

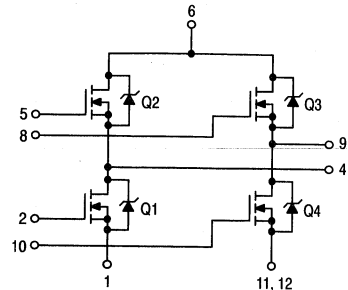

**H-Bridge**  
**MPM3017**

Devices listed in bold, italic are Motorola preferred devices.





# Isotop™ Isolated SOT-227B

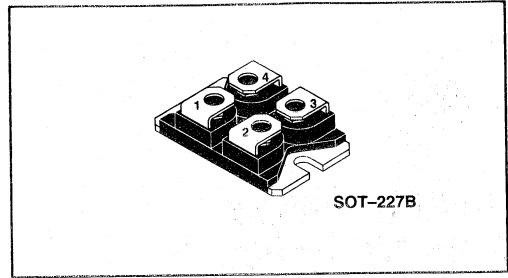

This new internally isolated high power package achieves low  $R_{DS(on)}$  by paralleling multiple die. Rated at 460 watts, the Isotop package exceeds the power dissipation ratings of all other power MOSFET packages. This package has a 2.5 kV isolation voltage.

Table 1. Isotop Isolated SOT-227B

$V_{(BR)DSS}$ (Volts) Min	$R_{DS(on)}$ (Ohms) Max	@	$I_D$ (Amps)	Device	$I_D$ (cont) Amps	$P_D^{(1)}$ (Watts) Max
500	0.08		26.5	<b><i>MTE53N50E</i></b>	53	460
200	0.015		62.5	<b><i>MTE125N20E</i></b>	125	460
100	0.0055		107	<b><i>MTE215N10E</i></b>	215	460

(1)  $T_C = 25^\circ\text{C}$

5

Devices listed in bold, italic are Motorola preferred devices.



## SMARTDISCRETES Products

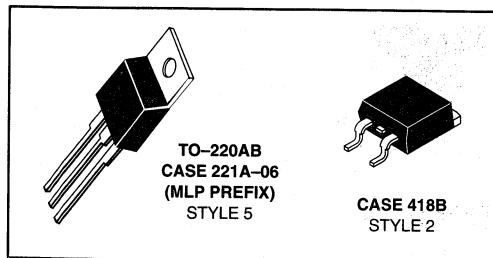

From a standard power MOSFET process, several active and passive elements can be obtained that provide on-chip protection to the basic power device. Such elements require only a small increase in silicon area and/or the addition of one masking layer to the process. The resulting device exhibits significant improvements in ruggedness and reliability and a system cost reduction. These SMARTDISCRETES™ functions can now provide an economical alternative to smart power ICs for power applications requiring low on-resistance, high voltage and high current.

These devices make up a series of "smart" power devices that automatically clamp spikes in automotive ignition systems and guard against ESD. The devices feature a logic level IGBT (Insulated Gate Bipolar Transistor) with integral active collector clamp and ESD gate protection and are designed primarily as ignition coil drivers to withstand high current in a pulsed mode without latching.

**Table 1. Ignition IGBTs**

BV <sub>CES</sub> (Volts) Clamped	V <sub>CE(on)</sub> @ 10 A	Device	P <sub>D</sub> (1) (Watts) Max	Package
350 V	1.8	<i>MGP20N35CL</i> <i>MGB20N35CL</i>	150 2.5(3)(4)	TO-220AB D <sup>2</sup> PAK
400 V	1.8	<i>MGP20N40CL</i> <i>MGB20N40CL</i>	150 2.5(3)(4)	TO-220AB D <sup>2</sup> PAK

(1) T<sub>C</sub> = 25°C

(3) Power rating when mounted on an FR-4 glass epoxy printed circuit board with the minimum recommended footprint.

(4) DPAK and D<sup>2</sup>PAK packages available in tape and reel — add T4 suffix to part number.

5

The MLP1N06CL is a SMARTDISCRETES device that has integrated on-chip current limit capability, drain-to-source voltage clamping and gate voltage protection. The logic level processing allows operation of this device at half of the gate-to-source (5 volts) voltage of the conventional MOSFETs and can now be driven directly from CMOS or TTL logic drivers. This integration of technologies results in an intelligent, monolithic power circuit that offers a reduced parts count and improved reliability by replacing resistors, diodes, a bipolar transistor and a MOSFET with one device all of which are packaged in a TO-220AB package.

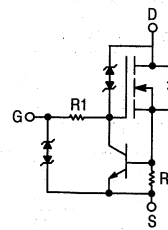

MLP1N06CL

**Table 2. TO-220AB — MLP1N06CL**

V <sub>(BR)DSS</sub> (Volts) Min	R <sub>DS(on)</sub> (Ohms) Max	I <sub>D</sub> (Amps)	Device	I <sub>D</sub> (cont) Amps	P <sub>D</sub> (1) (Watts) Max
60 Clamped Voltage	0.75	1	<i>MLP1N06CL</i>	Current Limited	40
62 Clamped Voltage	0.4	2	MLP2N06CL	Current Limited	40

(1) T<sub>C</sub> = 25°C

Devices listed in bold, italic are Motorola preferred devices.



## TMOS V

### Motorola Introduces Fifth Generation TMOS Technology

Planned as an introduction in mid 1994, the Power Products Division will introduce a new technology in the low voltage TMOS transistor family. This new generation technology is currently referred to as TMOS V. It is revolutionary rather than evolutionary.

The TMOS V technology will more than double the present cell density of our TMOS Power MOSFETs. This new technology will result in a tighter overall distribution of electrical parameters and optimizes the performance of our 50 and 60 volt portfolio.

This is a high cell density process of the future that will produce a new line of industry standard devices. Power transistors can now be built with the same high resolution/small geometry MOS fabrication technology that is standard in Motorola's ASIC, microprocessor and Memory Wafer Fabs.

The TMOS V technology will initially be offered in the DPAK and TO-220 packages and in the future will be available in our newer surface mount packages, such as the D<sup>2</sup>PAK and SOT-223. Samples will be available in 3Q94 and be in volume production in 4Q94.

Table 1. TMOS V — N-Channel

V(BR)DSS (Volts) Min	R <sub>DS(on)</sub> (Ohms) Max	@ I <sub>D</sub> (Amps)	Device	I <sub>D</sub> (cont) Amps	P <sub>D</sub> <sup>(1)</sup> (Watts) Max
60	0.15	6	<i>MTP3055V</i>	12	40
	0.12	7.50	<i>MTP15N06V</i>	15	53
	0.085	10	<i>MTP20N06V</i>	20	62
	0.06	12.50	<i>MTP25N06V</i>	25	72
	0.04	16	<i>MTP36N06V</i>	32	88
	0.028	22.50	<i>MTP50N06V</i>	45	107

5

Table 2. TMOS V — P-Channel

V(BR)DSS (Volts) Min	R <sub>DS(on)</sub> (Ohms) Max	@ I <sub>D</sub> (Amps)	Device	I <sub>D</sub> (cont) Amps	P <sub>D</sub> <sup>(1)</sup> (Watts) Max
60	0.500	3.50	<i>MTP7P06V</i>	7	48
	0.300	5	<i>MTP2955V</i>	10	60
	0.200	6.50	<i>MTP13P06V</i>	13	65
	0.160	8.50	<i>MTP16P06V</i>	17	90
	0.090	12.50	<i>MTP25P06V</i>	25	115
	0.060	17	<i>MTP30P06V</i>	34	140

(1) T<sub>C</sub> = 25°C

Devices listed in bold, italic are Motorola preferred devices.

# Bipolar Power Transistors

---





## In Brief . . .

Motorola's broad line of Bipolar Power Transistors includes discrete and Darlington transistors in a variety of packages from the popular surface mount DPAK at 1.75 watts to the 250 watt TO-3 and TO-264. New products include the MJE/MJF 18000 series for lamp ballast and power supplies, MJL16218 — a new 1500 V deflection transistor for video monitor applications, and high performance audio output devices in the TO-264 package. We have the broadest line of Bipolar Power Transistors in the industry and the Motorola commitment to quality and total customer satisfaction to go with them.

	<b>Page</b>
Bipolar Power Transistors . . . . .	5.5-2
Selection by Package . . . . .	5.5-2
Plastic (Isolated TO-220 Type) . . . . .	5.5-3
Plastic TO-220AB . . . . .	5.5-4
Plastic TO-218 Type . . . . .	5.5-7
Plastic TO-247 Type . . . . .	5.5-9
Large Plastic TO-264 . . . . .	5.5-10
Plastic TO-225AA Type (Formerly TO-126 Type) . . . . .	5.5-10
DPAK — Surface Mount Power Packages . . . . .	5.5-12
Metal TO-204AA (Formerly TO-3), TO-204AE . . . . .	5.5-13
Audio . . . . .	5.5-18
CRT Deflection . . . . .	5.5-19

# Bipolar Power Transistors

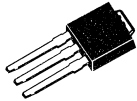
## Selection by Package

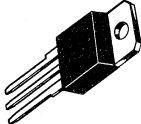
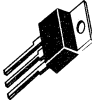
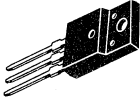
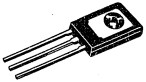
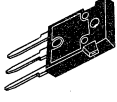
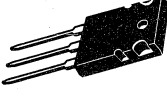
Package	I <sub>c</sub> Range (Amps)	V <sub>CE</sub> Range (Volts)	P <sub>D</sub> (Watts)	Page #
	4-30	40-1500	90-250	5.3-32
	50-80	60-1000	150-300	5.3-32
	0.5-10	40-400	12.5-20	5.3-31
	0.5-10	40-400	12.5-20	5.3-31
	5.0-25	60-1500	80-150	5.3-26
	0.5-15	30-1800	30-125	5.3-23
	1-12	80-450	20-45	5.3-22
	0.3-5.0	25-400	12.5-40	5.3-29
	10-30	400-1500	125-180	5.3-28
	15-16	200-250	250	5.3-29

5

**CASE 221D**  
Isolated TO-220 Type  
UL Recognized  
File #E69369

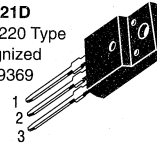

STYLE 1:  
PIN 1. BASE  
2. COLLECTOR  
3. EMITTER

**Table 1. Plastic (Isolated TO-220 Type)**

I <sub>C</sub> Cont Amps Max	V <sub>CEO(sus)</sub> Volts Min	V <sub>CES</sub> Volts Min	Device Type		h <sub>FE</sub> Min/Max	@ I <sub>C</sub> Amp	Resistive Switching			f <sub>T</sub> MHz Min	P <sub>D</sub> (Case) Watts @ 25°C	
			NPN	PNP			t <sub>s</sub> μs Max	t <sub>f</sub> μs Max	@ I <sub>C</sub> Amp			
1	250		<b>MJF47</b>		30/150	0.3	2 typ	0.17 typ	0.3	10	28	
2	400	700	<b>BUL44F</b>		14/34	0.2	2.75 <sup>(3)</sup>	0.2 <sup>(3)</sup>	1	13 typ	25	
		1000	<b>MJF18002</b>		14/34	0.2	2.75 <sup>(3)</sup>	0.175 <sup>(3)</sup>	1	13 typ	25	
3	100		<b>MJF31C</b>	<b>MJF32C</b>	10 min	1	0.6	0.3	1	3	28	
5	100		<b>MJF122<sup>(2)</sup></b>	<b>MJF127<sup>(2)</sup></b>	2000 min	3	1.5 typ	1.5 typ	3	4 <sup>(1)</sup>	28	
		400	700	<b>BUL45F</b>		14/34	0.3	1.7 <sup>(3)</sup>	0.15 <sup>(3)</sup>	1	12 typ	35
		450	1000	<b>BUT11AF</b>		10 min	.005	4	0.8	2.5		40
			1000	<b>MJF16002</b>		5 min	5	3	0.3	3		40
		1000	<b>MJF18004</b>		14/34	0.3	1.7 <sup>(3)</sup>	0.15 <sup>(3)</sup>	1	13 typ	35	
550	1200	<b>MJF18204</b>		18/35	0.5	2.75 <sup>(3)</sup>	0.2 <sup>(3)</sup>	2	12	35		
6	250	550	<b>MJF16204</b>		5 min	6	1.5 <sup>(3)</sup>	0.15 <sup>(3)</sup>	1	10	45	
		700	<b>BUL146F</b>		14/34	0.5	2.5 <sup>(3)</sup>	0.15 <sup>(3)</sup>	3	14 typ	40	
		1000	<b>MJF18006</b>		14/34	0.5	3.2 <sup>(3)</sup>	0.15 <sup>(3)</sup>	3	14 typ	40	
8	80			<b>MJF6107</b>	30/90	2	0.5 typ	0.13 typ	2	4	35	
			<b>MJF15030</b>	<b>MJF15031</b>	40 min	3	1 typ	0.15 typ	3	30	35	
		400	700	<b>MJF13007</b>		5/30	5	3	0.7	5	4	40
				<b>BUL147F</b>		14/34	1	2.5 <sup>(3)</sup>	0.18 <sup>(3)</sup>	2	14 typ	45
450	1000	<b>MJF18008</b>		16/34	1	2.75 <sup>(3)</sup>	0.18 <sup>(3)</sup>	2	13 typ	45		
10	60		<b>MJF3055</b>	<b>MJF2955</b>	20/100	4	—	—	—	2	40	
			<b>MJF44H11</b>	<b>MJF45H11</b>	40/100	4	0.5 typ	0.14 typ	5	40	35	
			<b>MJF6388<sup>(2)</sup></b>	<b>MJF6668<sup>(2)</sup></b>	3k/20k	3	1.5 typ	1.5 typ		20 <sup>(1)</sup>	40	
		1000	<b>MJF18009</b>		14/34	1.5	2.75 <sup>(3)</sup>	0.2 <sup>(3)</sup>	3	12	50	
12	400	700	<b>MJF13009</b>		6/30	8	3	0.7	8	8	40	

<sup>(1)</sup>h<sub>FEI</sub> @ 1 MHz

<sup>(2)</sup>Darlington

<sup>(3)</sup>Switching tests performed w/special application simulator circuit. See data sheet for details.

**5**

Devices listed in bold, italic are Motorola preferred devices.

STYLE 1:  
 PIN 1. BASE  
 2. COLLECTOR  
 3. EMITTER  
 4. COLLECTOR

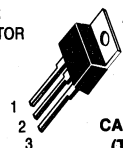

CASE 221A-06  
(TO-220AB)

Table 2. Plastic TO-220AB

I <sub>C</sub> Cont Amps Max	V <sub>CEO(sus)</sub> Volts Min <sup>(8)</sup>	Device Type		hFE Min/Max	@ I <sub>C</sub> Amp	Resistive Switching			f <sub>T</sub> MHz Min	P <sub>D</sub> (Case) Watts @ 25°C
		NPN	PNP			t <sub>s</sub> μs Max	t <sub>f</sub> μs Max	@ I <sub>C</sub> Amp		
0.5	350	<i>MJE2360T</i>		15 min	0.1				10 typ	30
		<i>MJE2361T</i>		40 min	0.1				10 typ	30
1	80	TIP29B	TIP30B	15/75	1	0.6 typ	0.3 typ	1	3	30
	100	TIP29C	TIP30C	15/75	1	0.6 typ	0.3 typ	1	3	30
	250	<i>TIP47</i>		30/150	0.3	2 typ	0.18 typ	0.3	10	40
	300	<i>TIP48</i>	<i>MJE5730</i>	30/150	0.3	2 typ	0.18 typ	0.3	10	40
	350	<i>TIP49</i>	<i>MJE5731</i>	30/150	0.3	2 typ	0.18 typ	0.3	10	40
	400	<i>TIP50</i>	<i>MJE5731A</i> <sup>(7)</sup>	30/150	0.3	2 typ	0.18 typ	0.3	10	40
2	60	TIP110 <sup>(2)</sup>	TIP115 <sup>(2)</sup>	500 min	2	1.7 typ	1.3 typ	2	25 <sup>(1)</sup>	50
	80	<i>TIP111</i> <sup>(2)</sup>	<i>TIP116</i> <sup>(2)</sup>	500 min	2	1.7 typ	1.3 typ	2	25 <sup>(1)</sup>	50
	100	<i>TIP112</i> <sup>(2)(6)</sup>	<i>TIP117</i> <sup>(2)(6)</sup>	500 min	2	1.7 typ	1.3 typ	2	25 <sup>(1)</sup>	50
	400/700	<i>BUL44</i>		14/36	0.4	2.75 <sup>(3)</sup>	0.175 <sup>(3)</sup>	1	13 typ	50
	450/1000	<i>BUX85</i>		30	0.1	3.5	1.4	1	4	50
	450/1000	<i>MJE18002</i>		14/34	0.2	3 <sup>(3)</sup>	0.17 <sup>(3)</sup>	1	12 typ	40
900/1800	<i>MJE1320</i>		3 min	1	4 typ	0.8 typ	1		80	
3	60	TIP31A	TIP32A	25 min	1	0.6 typ	0.3 typ	1	3	40
	80	<i>BD241B</i>	<i>BD242B</i>	25 min	1				3	40
		<i>TIP31B</i>	<i>TIP32B</i>	25 min	1	0.6 typ	0.3 typ	1	3	40
	100	<i>BD241C</i>	<i>BD242C</i>	25 min	1				3	40
		<i>TIP31C</i> <sup>(6)</sup>	<i>TIP32C</i> <sup>(6)</sup>	25 min	1	0.6 typ	0.3 typ	1	3	40
	150		<i>MJE9780</i>	50/200	0.5				5 typ	40

(1)h<sub>FEI</sub> @ 1 MHz

(2)Darlington

(3)Switching tests performed w/special application simulator circuit. See data sheet for details.

(6)Available as preferred chip.

(7)V<sub>CEO</sub> = 375 V

(8)When 2 voltages are given, the format is V<sub>CEO(sus)</sub>/V<sub>CEs</sub>.

Devices listed in bold, italic are Motorola preferred devices.

5

Table 2. Plastic TO-220AB (continued)

I <sub>C</sub> Cont Amps Max	V <sub>CEO(sus)</sub> Volts Min <sup>(8)</sup>	Device Type		h <sub>FE</sub> Min/Max	@ I <sub>C</sub> Amp	Resistive Switching			f <sub>T</sub> MHz Min	P <sub>D</sub> (Case) Watts @ 25°C
		NPN	PNP			t <sub>s</sub> μs Max	t <sub>f</sub> μs Max	@ I <sub>C</sub> Amp		
4	40		<b>MJE1123</b>	45/100	4				5	75
	60	<b>MJE800T</b> <sup>(2)</sup>	<b>MJE700T</b> <sup>(2)</sup>	750 min	1.5				1 <sup>(1)</sup>	40
	80	<b>D44C12</b>	<b>D45C12</b>	40/120	0.2			1	40 typ	30
	400/700	<b>MJE13005</b>		6/30	3	3	0.7	3	4	60
5	60	TIP120 <sup>(2)</sup>	TIP125 <sup>(2)</sup>	1k min	3	1.5 typ	1.5 typ	3	4 <sup>(1)</sup>	65
	80	<b>TIP121</b> <sup>(2)</sup>	<b>TIP126</b> <sup>(2)</sup>	1k min	3	1.5 typ	1.5 typ	3	4 <sup>(1)</sup>	65
	100	<b>TIP122</b> <sup>(2)(6)</sup>	<b>TIP127</b> <sup>(2)(6)</sup>	1k min	3	1.5 typ	1.5 typ	4	4 <sup>(1)</sup>	75
	250	<b>2N6497</b>		10/75	2.5	1.8	0.8	2.5	5	80
	300	<b>2N6498</b>		10/75	2.5	1.8	0.8	2.5	5	80
	400/700	<b>BUL45</b>		14/34	0.3	1.7 <sup>(3)</sup>	0.15 <sup>(3)</sup>	1	12 typ	75
	450/1000	<b>MJE16002</b>		5 min	5	3	0.3	3		80
	450/850	<b>MJE16004</b>		7 min	5	2.7	0.35	3		80
	450/1000	<b>MJE18004</b>		14/34	0.3	1.7	0.15	1.0	13	75
	550/1200	<b>MJE18204</b>		18/35	0.5	2.75 <sup>(3)</sup>	0.2 <sup>(3)</sup>	2	12	75
	700/1500	<b>MJE8503A</b>		7.5	1	4	2	2.5	7 typ	80
	6	60	TIP41A	TIP42A	15/75	3	0.4 typ	0.15 typ	3	3
80		<b>TIP41B</b>	<b>TIP42B</b>	15/75	3	0.4 typ	0.15 typ	3	3	65
		<b>BD243B</b>	<b>BD244B</b>	15 min	3	0.4 typ	0.15 typ	3	3	65
100		<b>BD243C</b>	<b>BD244C</b>	15 MIN	3	0.4 typ	0.15 typ	3	3	65
		<b>TIP41C</b>	<b>TIP42C</b>	15/75	3	0.4 typ	0.15 typ	3	3	65
250/550		<b>MJE16204</b>		5 min	6	1.5 <sup>(2)</sup>	0.15 <sup>(2)</sup>	1	10	80
400/700		<b>BUL146</b>		14/34	0.5	1.75 <sup>(3)</sup>	0.15 <sup>(3)</sup>	3	14 typ	100
450/1000		<b>MJE18006</b>		14/34	0.5	3.2 <sup>(3)</sup>	0.13 <sup>(3)</sup>	3	14 typ	100
7	30	2N6288	2N6111	30/150	3	0.4 typ	0.15 typ	3	4	40
	50		2N6109	30/150	2.5	0.4 typ	0.15 typ	3	4	40
	70	<b>2N6292</b>	<b>2N6107</b>	30/150	2	0.4 typ	0.15 typ	3	4	40
	100	<b>BD801</b>	<b>BD802</b>	15 min	3				3	65
	150	<b>BU407,D</b>		30 min	1.5		0.75	5	10	60
	200	<b>BU406,D</b>		30 min	1.5		0.75	5	10	60
	450	<b>BU522B</b> <sup>(2)</sup>		250 min	2.5				7.5	75

(1) h<sub>FE</sub> @ 1 MHz

(2) Darlington

(3) Switching tests performed w/special application simulator circuit. See data sheet for details.

(6) Available as preferred chip.

(7) V<sub>CEO</sub> = 375 V

(8) When 2 voltages are given, the format is V<sub>CEO(sus)</sub>/V<sub>CES</sub>.

5

Devices listed in bold, italic are Motorola preferred devices.



Table 2. Plastic TO-220AB (continued)

I <sub>C</sub> Cont Amps Max	V <sub>CEO(sus)</sub> Volts Min <sup>(8)</sup>	Device Type		h <sub>FE</sub> Min/Max	@ I <sub>C</sub> Amp	Resistive Switching			f <sub>T</sub> MHz Min	P <sub>D</sub> (Case) Watts @ 25°C
		NPN	PNP			t <sub>s</sub> μs Max	t <sub>f</sub> μs Max	@ I <sub>C</sub> Amp		
8	60	2N6043 <sup>(2)</sup>	2N6040 <sup>(2)</sup>	1k/10k	4	1.5 typ	1.5 typ	3	4 <sup>(1)</sup>	75
		TIP100 <sup>(2)</sup>	TIP105 <sup>(2)</sup>	1k/20k	3	1.5 typ	1.5 typ	3	4 <sup>(1)</sup>	80
	80	<b>2N6044<sup>(2)</sup></b>	<b>2N6041<sup>(2)</sup></b>	1k/10k	4	1.5 typ	1.5 typ	3	4 <sup>(1)</sup>	75
		<b>BDX53B<sup>(2)</sup></b>	<b>BDX54B<sup>(2)</sup></b>	750 min	3				4 <sup>(1)</sup>	60
		<b>TIP101<sup>(2)</sup></b>	<b>TIP106<sup>(2)</sup></b>	1k/20k	3	1.5 typ	1.5 typ	3	4 <sup>(1)</sup>	80
	100	<b>2N6045<sup>(2)</sup></b>	<b>2N6042<sup>(2)</sup></b>	1k/10k	3	1.5 typ	1.5 typ	3	4 <sup>(1)</sup>	75
		<b>BDX53C<sup>(2)</sup></b>	<b>BDX54C<sup>(2)</sup></b>	750 min	3					
		<b>TIP102<sup>(2)</sup></b>	<b>TIP107<sup>(2)</sup></b>	1k/20k	3	1.5 typ	1.5 typ	3	4 <sup>(1)</sup>	80
	120	<b>MJE15028</b>	<b>MJE15029</b>	20 min	4				30	50
	150	<b>MJE15030<sup>(6)</sup></b>	<b>MJE15031<sup>(6)</sup></b>	20 min	4				30	50
	200	<b>BU806<sup>(2)</sup></b>		100 min	5	0.55 typ	0.2 typ	5		60
	300/600	MJE5740 <sup>(2)</sup>		200 min	4	8 typ	2 typ	6	4	80
				MJE5850	15 min	2	2	0.5	4	
	350	<b>MJE5741<sup>(2)</sup></b>		200 min	4	8 typ	2 typ	6		80
				<b>MJE5851</b>	15 min	2	2	0.5	4	
		<b>MJE5742<sup>(2)</sup></b>		200 min	4	8 typ	2 typ	6		80
		<b>MJE13007<sup>(6)</sup></b>		5/30	5	3	0.7	5		80
		<b>MJE5852<sup>(6)</sup></b>	15 min	2	2	0.5	4		80	
400/650	<b>MJE16106</b>		6/22	8	2 typ	0.1 typ	5		100	
400/700	<b>BUL147</b>		14/34	1	2.5 <sup>(3)</sup>	0.18 <sup>(3)</sup>	2	14 typ	125	
450/1000	<b>MJE18008</b>		16/34	1	2.75 <sup>(3)</sup>	0.18 <sup>(3)</sup>	2	13 typ	125	
10	20	<b>MJE5420Z<sup>(2)(9)</sup></b>		6k min	6					100
			<b>BD808</b>	15 min	4				1.5	90
	60	<b>D44H8</b>	<b>D45H8</b>	40 min	4					50
		<b>MJE3055T</b>	<b>MJE2955T</b>	20/70	4					75
		<b>2N6387<sup>(2)</sup></b>	<b>2N6667<sup>(2)</sup></b>	1k/20k	5				20 <sup>(1)</sup>	65
	80	<b>BDX33B<sup>(2)</sup></b>	<b>BDX34B<sup>(2)</sup></b>	750 min	3				3	70
		<b>BD809</b>	<b>BD810</b>	15 min	4				1.5	90
		<b>D44E3<sup>(2)</sup></b>		1000 min	5	2 typ	0.5 typ	10		50
		<b>2N6388<sup>(2)(6)</sup></b>	<b>2N6668<sup>(2)(6)</sup></b>	1k/20k	5				20 <sup>(1)</sup>	65
		<b>D44H10</b>	<b>D45H10</b>	20 min	4	0.5 typ	0.14 typ	5	50 typ	50
<b>D44H11<sup>(6)</sup></b>		<b>D45H11<sup>(6)</sup></b>	40 min	4	0.5 typ	0.14 typ	5	50 typ	50	

(1) |h<sub>FE</sub>| @ 1 MHz

(2) Darlington

(3) Switching tests performed w/special application simulator circuit. See data sheet for details.

(6) Available as preferred chip.

(7) V<sub>CEO</sub> = 375 V

(8) When 2 voltages are given, the format is V<sub>CEO(sus)</sub>/V<sub>CE</sub>S.

(9) Self protected Darlington

Devices listed in bold, italic are Motorola preferred devices.

5

Table 2. Plastic TO-220AB (continued)

I <sub>C</sub> Cont Amps Max	V <sub>CEO(sus)</sub> Volts Min <sup>(8)</sup>	Device Type		hFE Min/Max	@ I <sub>C</sub> Amp	Resistive Switching			f <sub>T</sub> MHz Min	P <sub>D</sub> (Case) Watts @ 25°C
		NPN	PNP			t <sub>s</sub> μs Max	t <sub>f</sub> μs Max	@ I <sub>C</sub> Amp		
10	100	<b>BDX33C</b> <sup>(2)</sup>	<b>BDX34C</b> <sup>(2)</sup>	750 min	3				3	70
	450/1000	<b>MJE18009</b>		14/34	1.5	2.75 <sup>(3)</sup>	0.2 <sup>(3)</sup>	3	12	150
12	400/700	<b>MJE13009</b>		6/30	8	3	0.7	8	4	100
15	60	<b>2N6487</b>	<b>2N6490</b>	20/150	5	0.6 typ	0.3 typ	5	5	75
	80	<b>2N6488</b>	<b>2N6491</b>	20/150	5	0.6 typ	0.3 typ	5	5	75
		<b>D44VH10</b>	<b>D45VH10</b>	20 min	4	0.5	0.09	8	50 typ	83
	100	<b>BDW42</b> <sup>(2)</sup>	<b>BDW47</b> <sup>(2)</sup>	1k min	5	1 typ	1.5 typ	5	4	85

STYLE 1:

- PIN 1. BASE
2. COLLECTOR
3. EMITTER
4. COLLECTOR

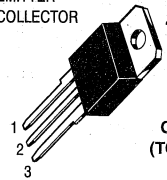

CASE 340D  
(TO-218 Type,  
SOT-93)

Table 3. Plastic TO-218 Type

I <sub>C</sub> Cont Amps Max	V <sub>CEO(sus)</sub> Volts Min <sup>(8)</sup>	Device Type		hFE Min/Max	@ I <sub>C</sub> Amp	Resistive Switching			f <sub>T</sub> MHz Min	P <sub>D</sub> (Case) Watts @ 25°C
		NPN	PNP			t <sub>s</sub> μs Max	t <sub>f</sub> μs Max	@ I <sub>C</sub> Amp		
5	450/850	<b>MJH16002</b>		5 min	5	3	0.3	3		100
	450/850	MJH16004		7 min	5	2.7	0.35	3		100
	500/1000	<b>MJH16002A</b>		5 min	5	3	0.3	3		100
8	450/850	<b>MJH16006</b>		5 min	8	2.5	0.25	5		125
		MJH16008		7 min	8	2.2	0.25	5		125
	500/1000	<b>MJH16006A</b>		5 min	8	2.5	0.25	5		125
	700/1500	BU508A		2.25 min	4.5	8 typ	0.5 typ	4.5	7	125
10	60	TIP140 <sup>(2)</sup>	TIP145 <sup>(2)</sup>	500 min	10	2.5 typ	2.5 typ	5	4 <sup>(1)</sup>	125
	80	<b>TIP33B</b>	<b>TIP34B</b>	20/100	3				3	80
		<b>TIP141</b> <sup>(2)</sup>	<b>TIP146</b> <sup>(2)</sup>	500 min	10	2.5 typ	2.5 typ	5	4 <sup>(1)</sup>	125
		<b>BDV65B</b> <sup>(2)</sup>	<b>BDV64B</b> <sup>(2)</sup>	1k min	5					125
	100	TIP33C	TIP34C	20/100	3				3	80
		TIP142 <sup>(2)</sup>	TIP147 <sup>(2)</sup>	500 min	10	2.5 typ	2.5 typ	5	4 <sup>(1)</sup>	125
		400	<b>BU323AP</b> <sup>(2)</sup>		150/100	6	15	15	6	
	<b>MJH10012</b> <sup>(2)</sup>		100/2k	6	15	15	6		118	

<sup>(1)</sup>h<sub>FEI</sub> @ 1 MHz

<sup>(2)</sup>Darlington

<sup>(8)</sup>When 2 voltages are given, the format is V<sub>CEO(sus)</sub>/V<sub>CES</sub>.

Devices listed in bold, italic are Motorola preferred devices.

Table 3. Plastic TO-218 Type (continued)

I <sub>C</sub> Cont Amps Max	V <sub>CEO(sus)</sub> Volts Min <sup>(8)</sup>	Device Type		h <sub>FE</sub> Min/Max	@ I <sub>C</sub> Amp	Resistive Switching			f <sub>T</sub> MHz Min	PD (Case) Watts @ 25°C
		NPN	PNP			t <sub>s</sub> μs Max	t <sub>f</sub> μs Max	@ I <sub>C</sub> Amp		
15	60	<i>TIP3055</i>	<i>TIP2955</i>	5 min	10				2.5	80
	150	<i>MJH11018</i> <sup>(2)</sup>	<i>MJH11017</i> <sup>(2)</sup>	400/15k	10				3	150
	200	<i>MJH11020</i> <sup>(2)</sup>	<i>MJH11019</i> <sup>(2)</sup>	400/15k	10				3	150
	250	<i>MJH11022</i> <sup>(2)</sup>	<i>MJH11021</i> <sup>(2)</sup>	400/15k	10				3	150
	400	<i>BUV48</i>		8 min	10	2	0.4	10		150
	450	<i>BUV48A</i>		8 min	8	2	0.4	10		150
16	500	<i>BUT51P</i> <sup>(2)</sup>		40 min	5	1.1	0.16	10		125
	140	<i>MJE4342</i>	<i>MJE4352</i>	15 min	8	1.2 typ	1.2 typ	8	1	125
20	160	<i>MJE4343</i>	<i>MJE4353</i>	15 min	8	1.2 typ	1.2 typ	8	1	125
	60	<i>MJH6282</i> <sup>(2)</sup>	<i>MJH6285</i> <sup>(2)</sup>	750/18k	10				4	125
	80	<i>MJH6283</i> <sup>(2)</sup>	<i>MJH6286</i> <sup>(2)</sup>	750/18k	10				4	125
25	80	<i>TIP35A</i>	<i>TIP36A</i>	15/75	15	0.6 typ	0.3 typ	10	3	125
		<i>TIP35B</i>	<i>TIP36B</i>	15/75	15	0.6 typ	0.3 typ	10	3	125
	100	<i>BD249C</i>	<i>BD250C</i>	10 min	15				3	125
		<i>TIP35C</i>	<i>TIP36C</i>	15/75	15	0.6 typ	0.3 typ	10	3	125

<sup>(2)</sup>Darlington

<sup>(8)</sup>When 2 voltages are given, the format is V<sub>CEO(sus)</sub>/V<sub>CE(s)</sub>.

5

Devices listed in bold, italic are Motorola preferred devices.

STYLE 2:

- PIN 1. BASE
- 2. COLLECTOR
- 3. EMITTER

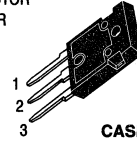

CASE 340F  
(TO-247 Type)

Table 4. Isolated Mounting Hole — Plastic TO-247 Type

I <sub>C</sub> Cont Amps Max	V <sub>CEO(sus)</sub> Volts Min	V <sub>CES</sub> Volts Min	Device Type		hFE Min/Max	@ I <sub>C</sub> Amp	Resistive Switching			f <sub>T</sub> MHz Min	P <sub>D</sub> (Case) Watts @ 25°C
			NPN	PNP			t <sub>s</sub> μs Max	t <sub>f</sub> μs Max	@ I <sub>C</sub> Amp		
10	650	1500	<b><i>MJW16212</i></b>		4/10	10	4(3)	0.5(3)	5.5		150
	800	1500	<b><i>MJW16018</i></b>		4 min	5	4.5 typ	0.2 typ	5	3 typ	150
12	500	1200	<b><i>MJW16206</i></b>		5/13	10	2.25	0.25	6.5	3 typ	150
15	400	650	<b><i>MJW6678</i></b>		8 min	15	2.5	0.5	15		125
	400	650	<b><i>MJW16110</i></b>		6/20	10	0.8 typ	0.1 typ	10		135
	450	850	<b><i>MJW16010</i></b>		5 min	15	1.2 typ	0.2 typ	10		150
		850	<b><i>MJW16012</i></b>		7 min	15	0.9 typ	0.15 typ	10		150
	500	1000	<b><i>MJW16010A</i></b>		5 min	15	3	0.4	10		150
		1000	<b><i>MJW16210</i></b>		5/13	15		0.24(10)	8.5(10)	2.5 typ	150

(3) Switching tests performed w/special application simulator circuit. See data sheet for details.

(10) Tested in Applications simulator: see Data Sheet.

Devices listed in bold, italic are Motorola preferred devices.

# New Product New Product New Product New Product

STYLE 2:  
 PIN 1. BASE  
 2. COLLECTOR  
 3. EMITTER

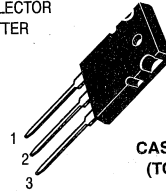

CASE 340G  
(TO-264)

Table 5. Large Plastic TO-264

I <sub>C</sub> Cont Amps Max	V <sub>CEO(sus)</sub> Volts Min	Device Type		hFE Min/Max	@ I <sub>C</sub> Amp	Resistive Switching			f <sub>T</sub> MHz Min	P <sub>D</sub> (Case) Watts @ 25°C
		NPN	PNP			t <sub>s</sub> μs Max	t <sub>f</sub> μs Max	@ I <sub>C</sub> Amp		
15	200	<b>MJL3281A</b>	<b>MJL1302A</b>	60/175	0.1				30 typ	200
	650/1500	<b>MJL1621B</b>		4/11	12				2.5 typ	170
16	250	<b>MJL21194</b>	<b>MJL21193</b>	25/75	8				4	200

STYLE 1:  
 PIN 1. EMITTER  
 2. COLLECTOR  
 3. BASE

STYLE 3:  
 PIN 1. BASE  
 2. COLLECTOR  
 3. EMITTER

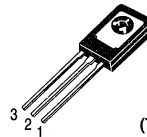

CASE 77  
(TO-225AA)

Table 6. Plastic TO-225AA Type (Formerly TO-126 Type)

I <sub>C</sub> Cont Amps Max	V <sub>CEO(sus)</sub> Volts Min	Device Type		hFE Min/Max	@ I <sub>C</sub> Amp	Resistive Switching			f <sub>T</sub> MHz Min	P <sub>D</sub> (Case) Watts @ 25°C
		NPN	PNP			t <sub>s</sub> μs Max	t <sub>f</sub> μs Max	@ I <sub>C</sub> Amp		
0.3	350	<b>MJE3439</b>		40/160	0.02				15	15
0.5	150	<b>MJE341</b>		25/200	0.05				15	20.8
	200	<b>MJE344</b>		30/300	0.05				15	20.8
	250	2N5655		30/250	0.1	3.5 typ	0.24 typ	0.1	10	20
		<b>BD157</b>		30/240	0.05					20
300	BD158		30/240	0.05					20	
	<b>MJE340</b> <sup>(6)</sup>	<b>MJE350</b> <sup>(6)</sup>	30/240	0.05					20.8	
	2N5656		30/250	0.1	3.5 typ	0.24 typ	0.1	10	20	

<sup>(6)</sup>Available as preferred chip.

Devices listed in bold, italic are Motorola preferred devices.

Table 6. Plastic TO-225AA Type (Formerly TO-126 Type) (continued)

I <sub>C</sub> Cont Amps Max	V <sub>CEO</sub> (sus) Volts Min	Device Type		h <sub>FE</sub> Min/Max	@ I <sub>C</sub> Amp	Resistive Switching			f <sub>T</sub> MHz Min	P <sub>D</sub> (Case) Watts @ 25°C
		NPN	PNP			t <sub>s</sub> μs Max	t <sub>f</sub> μs Max	@ I <sub>C</sub> Amp		
0.5	350	<b>2N5657</b>		30/250	0.1	3.5 typ	0.24 typ	0.1	10	20
		<b>BD159</b>		30/240	0.05					20
1	40	<b>2N4921</b>	<b>2N4918</b>	20/100	0.5	0.6 typ	0.3 typ	0.5	3	30
	60	<b>2N4922</b>	<b>2N4919</b>	20/100	0.5	0.6 typ	0.3 typ	0.5	3	30
	80	<b>2N4923</b>	<b>2N4920</b>	20/100	0.5	0.6 typ	0.3 typ	0.5	3	30
1.5	45	<b>BD165</b>	<b>BD166</b>	15 min	0.5				6	20
		<b>BD135</b>	<b>BD136</b>	40/250	0.15					12.5
	60	<b>BD137</b>	<b>BD138</b>	40/250	0.15					12.5
	80	<b>BD169</b>		15 min	0.5				6	20
		<b>BD139</b>	<b>BD140</b>	40/250	0.15					12.5
			<b>BD140.10</b>	63/160	0.15					12.5
	300	<b>MJE13002</b> (11)		5/25	1	4	0.7	1	5	40
400	<b>MJE13003</b> (6)(11)		5/25	1	4	0.7	1	5	40	
2	80	<b>BD237</b>	<b>BD238</b>	25 min	1				3	25
	100	<b>MJE270</b> (2)(11)	<b>MJE271</b> (2)(11)	1.5k min	0.12				6	15
3	60	<b>MJE181</b>	<b>MJE171</b>	50/250	0.1	0.6 typ	0.12 typ	0.1	50	12.5
	80	<b>BD179</b>	<b>BD180</b>	40/250	0.15				3	30
		<b>MJE182</b> (6)	<b>MJE172</b> (6)	50/250	0.1	0.6 typ	0.12 typ	0.1	50	12.5
200		<b>BUY49P</b>		30 min	0.5				25	20
	40	<b>MJE521</b>	<b>MJE371</b>	40 min	1					40
		45	<b>BD437</b>	<b>BD438</b>	40 min	2				3
60			<b>BD776</b> (2)	750 min	2				20	15
			<b>BD440</b>	25 min	2				3	36
		<b>BD677</b> (2)	<b>BD678</b> (2)	750 min	1.5					40
		<b>BD677A</b> (2)	<b>BD678A</b> (2)	750 min	2					40
		<b>BD787</b>	<b>BD788</b>	20 min	2				50	15
		<b>BD777</b> (2)	<b>BD778</b> (2)	750 min	2				20	15
		<b>2N5191</b>	<b>2N5194</b>	25/100	1.5	0.4 typ	0.4 typ	1.5	2	40
		<b>MJE800</b> (2)	<b>MJE700</b> (2)	750 min	1.5				1(1)	40
		<b>2N6038</b> (2)	<b>2N6035</b> (2)	750/18k	2	1.7 typ	1.2 typ	2	25	40
	80	<b>2N5192</b>	<b>2N5195</b>	25/100	1.5	0.4 typ	0.4 typ	1.5	2	40
		<b>BD441</b>	<b>BD442</b>	15 min	2				3	36
		<b>BD679</b> (2)	<b>BD680</b> (2)	750 min	1.5					40
		<b>BD679A</b> (2)	<b>BD680A</b> (2)	750 min	2					40
<b>BD789</b>		<b>BD790</b>	10 min	2				40	15	

(1) I<sub>hFE1</sub> @ 1 MHz  
 (2) Darlington  
 (6) Available as preferred chip.  
 (11) Case 77, Style 3

Devices listed in bold, italic are Motorola preferred devices.

5

Table 6. Plastic TO-225AA Type (Formerly TO-126 Type) (continued)

I <sub>C</sub> Cont Amps Max	V <sub>CEO(sus)</sub> Volts Min	Device Type		h <sub>FE</sub> Min/Max	@ I <sub>C</sub> Amp	Resistive Switching			f <sub>T</sub> MHz Min	P <sub>D</sub> (Case) Watts @ 25°C
		NPN	PNP			t <sub>s</sub> μs Max	t <sub>f</sub> μs Max	@ I <sub>C</sub> Amp		
4	80	<i>BD779</i> (2)	<i>BD780</i> (2)	750 min	2				20	15
		<i>MJE240</i>	<i>MJE250</i>	40/200	0.2	0.15 typ	0.07 typ	2	40	15
		<i>MJE241</i>	<i>MJE251</i>	40/120	0.2	0.15 typ	0.07 typ	2	40	15
		<i>MJE802</i> (2)	<i>MJE702</i> (2)	750 min	1.5				1(1)	40
		<i>MJE803</i> (2)	<i>MJE703</i> (2)	750 min	2				1(1)	40
		<i>2N6039</i> (2)	<i>2N6036</i> (2)	750/18k	2	1.7 typ	1.2 typ	2	25	40
	100	<i>BD681</i> (2)	<i>BD682</i> (2)	750 min	1.5					40
		<i>BD791</i>	<i>BD792</i>	10 min	2				40	15
<i>MJE243</i>		<i>MJE253</i>	40/120	0.2	0.15 typ	0.07 typ	2	40	15	
5	25	<i>MJE200</i> (6)	<i>MJE210</i> (6)	45/180	2	0.13 typ	0.035 typ	2	65	15

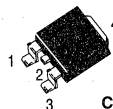

CASE 369A(13)

5

STYLE 1:  
PIN 1. BASE  
2. COLLECTOR  
3. EMITTER  
4. COLLECTOR

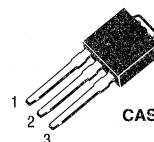

CASE 369(12)

Table 7. DPAK – Surface Mount Power Packages

I <sub>C</sub> Cont Amps Max	V <sub>CEO(sus)</sub> Volts Min	Device Type		h <sub>FE</sub> Min/Max	@ I <sub>C</sub> Amp	Resistive Switching			f <sub>T</sub> MHz Min	P <sub>D</sub> (Case) Watts @ 25°C
		NPN	PNP			t <sub>s</sub> μs Max	t <sub>f</sub> μs Max	@ I <sub>C</sub> Amp		
0.5	300	<i>MJD340</i>	<i>MJD350</i>	30/240	0.05					15
1	250	<i>MJD47</i>		30/150	0.3	2	0.2	0.3	10	15
	350		<i>MJD5731</i>	30/175	0.3	1.5	0.2	0.3	10	15
	400	<i>MJD50</i>		30/150	0.3	2	0.2	0.3	10	15
1.5	400	<i>MJD13003</i>		5/25	1	4	0.7	1	4	15

(1) h<sub>FE</sub> @ 1 MHz

(2) Darlington

(6) Available as preferred chip.

(12) Case 369-07 may be ordered by adding -1 suffix to part number.

(13) Case 369A-13 may be ordered as tape and reel by adding a "T4" suffix; 2500 units/reel.

Devices listed in bold, italic are Motorola preferred devices.

Table 7. DPAK – Surface Mount Power Packages (continued)

I <sub>C</sub> Cont Amps Max	V <sub>CEO(sus)</sub> Volts Min	Device Type		h <sub>FE</sub> Min/Max	@ I <sub>C</sub> Amp	Resistive Switching			f <sub>T</sub> MHz Min	P <sub>D</sub> (Case) Watts @ 25°C
		NPN	PNP			t <sub>s</sub> μs Max	t <sub>f</sub> μs Max	@ I <sub>C</sub> Amp		
2	100	<i>MJD112</i> (2)	<i>MJD117</i> (2)	1000 min	2	1.7	1.3	2	25(1)	20
3	40	<i>MJD31</i>	<i>MJD32</i>	10 min	1	0.6	0.3	1	3	15
	100	<i>MJD31C</i>	<i>MJD32C</i>	10 min	1	0.6	0.3	1	3	15
4	45	<i>MJD148</i>		30 min	4				3	20
	80	<i>MJD6039</i> (2)	<i>MJD6036</i> (2)	1k/12k	2	1.7	1.2	2	25	20
	100	<i>MJD243</i>	<i>MJD253</i>	40/180	0.2	0.16	0.04	1	40	12.5
5	25	<i>MJD200</i>	<i>MJD210</i>	45/180	2	0.15	0.04	2	65	12.5
6	100	<i>MJD41C</i>	<i>MJD42C</i>	15/75	3	0.4	0.15	3	3	20
8	80	<i>MJD44H11</i>	<i>MJD45H11</i>	40 min	4	0.5	0.14	5	50 typ	20
	100	<i>MJD122</i> (2)	<i>MJD127</i> (2)	1k/12k	4	1.5	2	4	4(1)	20
10	60	<i>MJD3055</i>	<i>MJD2955</i>	20/100	4	1.5	1.5	3	2	20
	80	<i>MJD44E3</i> (2)		1k min	5	2	0.5	10		20

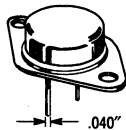

CASE 1-07  
TO-204AA

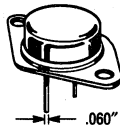

CASE 197A TO-204AE  
(Used for high current types at end of  
table. See types w/footnote(16).)

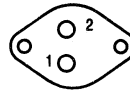

STYLE 1:  
PIN 1. BASE  
2. EMITTER  
3. COLLECTOR

5

Table 8. Metal TO-204AA (Formerly TO-3), TO-204AE

I <sub>C</sub> Cont Amps Max	V <sub>CEO(sus)</sub> Volts Min(8)	Device Type		h <sub>FE</sub> Min/Max	@ I <sub>C</sub> Amp	Resistive Switching			f <sub>T</sub> MHz Min	P <sub>D</sub> (Case) Watts @ 25°C
		NPN	PNP			t <sub>s</sub> μs Max	t <sub>f</sub> μs Max	@ I <sub>C</sub> Amp		
4	200	MJ15018	MJ15019	30 min	1				20	150
	250	<i>MJ15020</i>	<i>MJ15021</i>	30 min	1				20	150
5	500/1000	<i>MJ16002A</i>		5 min	5	3	0.3	3		125
	700/1500	<i>BU208A</i>		2.5 min	4.5	8 typ	0.4 typ	4.5	4 typ	90
6	100	<i>2N5758</i>		25/100	3	0.7 typ	0.5 typ	3	1	150
8	60	MJ1000(2)	MJ900(2)	1k min	3					90
		2N6055(2)	2N6053(2)	750/18k	4	1.5 typ	1.5 typ	4	4(1)	100
	80	<i>MJ1001</i> (2)	<i>MJ901</i> (2)	1k min	3					90
	80	<i>2N6056</i> (2)	<i>2N6054</i> (2)	750/18k	4	1.5 typ	1.5 typ	4	4(1)	100
	380	<i>MJ6308</i>		5/20	8	2.3(14)	0.12(14)	5		125

(1)h<sub>FEI</sub> @ 1 MHz

(2)Darlington

(8)When 2 voltages are given, the format is V<sub>CEO(sus)</sub>/V<sub>CES</sub>.

(12)Case 369 may be ordered by adding -1 suffix to part number.

(13)Case 369A may be ordered as tape and reel by adding a "T4" suffix; 2500 units/reel.

(14)Inductive switching

Devices listed in bold, italic are Motorola preferred devices.



Table 8. Metal TO-204AA (Formerly TO-3), TO-204AE (continued)

I <sub>C</sub> Cont Amps Max	V <sub>CEO(sus)</sub> Volts Min <sup>(8)</sup>	Device Type		h <sub>FE</sub> Min/Max	@ I <sub>C</sub> Amp	Resistive Switching			f <sub>T</sub> MHz Min	P <sub>D</sub> (Case) Watts @ 25°C	
		NPN	PNP			t <sub>s</sub> μs Max	t <sub>f</sub> μs Max	@ I <sub>C</sub> Amp			
8	400		<i>MJ6503</i>	15 min	2	2	0.5	4		125	
	450/850	<i>MJ16006</i>		5 min	8	2.5	0.25	5		150	
	450/1000	<i>MJ16008</i>		7 min	8	2.2	0.25	5		150	
	500/1000	MJ16006A		5 min	8	3	0.4	5		150	
10	60	2N3715	2N3791	30 min	3	0.3 typ	0.4 typ	5	4	150	
		2N5877	2N5875	20/100	4	1	0.8	4	4	150	
		MJ3000 <sup>(2)</sup>	MJ2500 <sup>(2)</sup>	1k min	5					150	
	80	<i>2N3716</i> <sup>(6)</sup>	<i>2N3792</i> <sup>(6)</sup>	30 min	3	0.3 typ	0.4 typ	5	4	150	
		<i>2N5878</i>	<i>2N5876</i>	20/100	4	1	0.8	4	4	150	
		MJ3001 <sup>(2)</sup>	MJ2501 <sup>(2)</sup>	1k min	5					150	
	140	<i>2N3442</i>		20/70	4					117	
	250	<i>MJ15011</i>	<i>MJ15012</i>	20/100	2					200	
	300	MJ3041 <sup>(2)</sup>		250 min	2.5					175	
	325	<i>MJ413</i>		20/80	0.5					2.5	125
		<i>MJ423</i>		30/90	1					2.5	125
	350	MJ13014		8/20	5	2	0.5	5		150	
	400	<i>BU323A</i> <sup>(2)</sup>		150 min	6	7.5 typ	5.2 typ	6			175
		<i>MJ10007</i> <sup>(2)</sup>		30/300	5	1.5	0.5	5	10 <sup>(1)</sup>		150
		<i>MJ10012</i> <sup>(2)</sup>		100/2k	6	15	15	6			175
		<i>MJ13015</i>		8/20	5	2	0.5	5			150
600	<i>MJ10014</i> <sup>(2)</sup>		10/250	10	2.5	0.8	10		175		
800/1500	<i>MJ16018</i>		4 min	5	4.5 typ	0.2 typ	5		150		
12	60	2N6057 <sup>(2)</sup>	2N6050 <sup>(2)</sup>	750/18k	6	1.6 typ	1.5 typ	6	4 <sup>(1)</sup>	150	
	80	2N6058 <sup>(2)</sup>	2N6051 <sup>(2)</sup>	750/18k	6	1.6 typ	1.5 typ	6	4 <sup>(1)</sup>	150	
	100	<i>2N6059</i> <sup>(2)(6)</sup>	<i>2N6052</i> <sup>(2)(6)</sup>	750/18k	6	1.6 typ	1.5 typ	6	4 <sup>(1)</sup>	150	
15	60	<i>2N3055</i> <sup>(6)</sup>	<i>MJ2955</i> <sup>(6)</sup>	20/70	4	0.7 typ	0.3 typ	4	2.5	115	
		<i>2N3055A</i>	<i>MJ2955A</i>	20/70	4				0.8	115	
		<i>2N6576</i> <sup>(2)</sup>		2k/20k	4	2	7	10	10-200 <sup>(1)</sup>	120	
		2N5881	2N5879	20/100	6	1	0.8	6	4	160	
	80	<i>2N5882</i> <sup>(6)</sup>	<i>2N5880</i> <sup>(6)</sup>	20/100	6	1	0.8	6	4	160	
	90	<i>2N6577</i> <sup>(2)</sup>		2k/20k	4	2	7	10	10-200 <sup>(1)</sup>	120	
	120	<i>MJ15015</i> <sup>(6)</sup>	<i>MJ15016</i>	20/70	4	0.7 typ	0.3 typ	4	1	180	
		<i>2N6578</i> <sup>(2)</sup>		2k/20k	4	2	7	10	10-200 <sup>(1)</sup>	120	
	140	<i>MJ15001</i>	<i>MJ15002</i>	25/150	4				2	200	
	150	MJ11018 <sup>(2)</sup>	MJ11017 <sup>(2)</sup>	100 min	15				3 <sup>(1)</sup>	175	
200	<i>BUX41</i>		8 min	8	1.5	0.4	8	8	120		
	<i>MJ11020</i> <sup>(2)</sup>		100 min	15				3 <sup>(1)</sup>	175		

(1) h<sub>FE</sub> @ 1 MHz

(2) Darlington

(6) Available as preferred chip.

(8) When 2 voltages are given, the format is V<sub>CEO(sus)</sub>/V<sub>CES</sub>.

Devices listed in bold, italic are Motorola preferred devices.

Table 8. Metal TO-204AA (Formerly TO-3), TO-204AE (continued)

I <sub>C</sub> Cont Amps Max	V <sub>CEO(sus)</sub> Volts Min <sup>(8)</sup>	Device Type		h <sub>FE</sub> Min/Max	@ I <sub>C</sub> Amp	Resistive Switching			f <sub>T</sub> MHz Min	P <sub>D</sub> (Case) Watts @ 25°C
		NPN	PNP			t <sub>s</sub> μs Max	t <sub>f</sub> μs Max	@ I <sub>C</sub> Amp		
15	200	<b>MJ3281A</b>	<b>MJ1302A</b>	60/175	0.1				30 typ	250
	250	<b>MJ11022</b> (2)(6)	<b>MJ11019</b> (2)(6)	100 min	15				3(1)	175
				<b>MJ11021</b> (2)	6/30	10	4	0.7	10	6 to 24
	350	<b>2N6251</b>		6/50	10	3.5	1	10	2.5	175
	400/850	<b>BUX48</b>		8 min	10	2	0.4	10		175
		<b>2N6547</b>		6/30	10	4	0.7	10	6 to 24	175
	400/650	<b>MJ16110</b>		6/20	15	0.8 typ	0.1 typ	10		175
	450/1000	<b>BUX48A</b>		8 min	8	2	0.4	10		175
	450/850	<b>MJ16010</b>		5 min	15	1.2 typ	0.2 typ	10		175
		<b>MJ16012</b> (6)		7 min	15	0.9 typ	0.15 typ	10		175
		<b>2N6836</b>		10/30	10	3	0.35	10	10	175
	500/1000	<b>MJ16010A</b>		5 min	15	3	0.4	10		175
16	120	<b>2N5630</b>	<b>2N6030</b>	20/80	8	1.2 typ	1.2 typ	8	1	200
	140	<b>2N3773</b> (6)	<b>2N6609</b>	15/60	8	1.1 typ	1.5 typ	8	4	150
			<b>2N5631</b>	<b>2N6031</b> (6)	15/60	8	1.2 typ	1.2 typ	8	1
	200	<b>MJ15022</b>	<b>MJ15023</b>	15/60	8				5	250
	250	<b>MJ15024</b>	<b>MJ15025</b>	15/60	8				5	250
		<b>MJ21194</b>	<b>MJ21193</b>	25/75	8				4	250
20	60	<b>2N3772</b>		15/60	10				2	150
		<b>2N6282</b> (2)	<b>2N6285</b> (2)	750/18k	10	2.5 typ	2.5 typ	10	4(1)	160
	75	<b>2N5039</b>		20/100	10	1.5	0.5	10	60	140
		<b>2N5303</b>	<b>2N5745</b>	15/60	10	2	1	10	2	200
	80	<b>2N6283</b> (2)	<b>2N6286</b> (2)	750/18k	10	2.5 typ	2.5 typ	10	4(1)	160
		<b>2N5038</b> (6)		20/100	12	1.5	0.5	12	60	140
	100	<b>2N6284</b> (2)(6)	<b>2N6287</b> (2)(6)	750/18k	10	2.5 typ	2.5 typ	10	4(1)	160
	140	<b>MJ15003</b> (6)	<b>MJ15004</b> (6)	25/150	5				2	250
	200	<b>BUV11</b>		10 min	12	1.8	0.4	12	8	150
	350	<b>MJ10000</b> (2)		40/400	10	3	1.8	10	10(1)	175
		<b>MJ10004</b> (2)		40/400	10	1.5	0.5	10	10(1)	175
	400	<b>MJ10001</b> (2)		40/400	10	3	1.8	10	10(1)	175
		<b>MJ10005</b> (2)		40/400	10	1.5	0.5	10	10(1)	175
		<b>MJ13333</b>		10/60	5	4	0.7	10		175
	450	<b>MJ10008</b> (2)		30/300	10	2	0.6	10	8(1)	175
	450/850	<b>MJ16014</b>		5 min	20	2.7	0.35	20		250
		<b>MJ16016</b>		7 min	20	2.2	0.25	20		250
	500	<b>MJ10009</b> (2)		30/300	10	2	0.6	10	8(1)	175
		<b>MJ13335</b>		10/60	5	4	0.7	10		175

(1)h<sub>FE</sub>l @ 1 MHz

(2)Darlington

(6)Available as preferred chip.

(8)When 2 voltages are given, the format is V<sub>CEO(sus)</sub>/V<sub>CEs</sub>.

Devices listed in bold, italic are Motorola preferred devices.

5

Table 8. Metal TO-204AA (Formerly TO-3), TO-204AE (continued)

I <sub>C</sub> Cont Amps Max	V <sub>CEO(sus)</sub> Volts Min <sup>(8)</sup>	Device Type		h <sub>FE</sub> Min/Max	@ I <sub>C</sub> Amp	Resistive Switching			f <sub>T</sub> MHz Min	P <sub>D</sub> (Case) Watts @ 25°C
		NPN	PNP			t <sub>s</sub> μs Max	t <sub>f</sub> μs Max	@ I <sub>C</sub> Amp		
25	60	2N5885	2N5883	20/100	10	1	0.8	10	4	200
	80	<b>2N5886</b> <sup>(6)</sup>	<b>2N5884</b> <sup>(6)</sup>	20/100	10	1	0.8	10	4	200
				2N6436	30/120	10	1	0.25	10	40
	100	<b>2N6338</b>	<b>2N6437</b>	30/120	10	1	0.25	10	40	200
	120	<b>2N6339</b> <sup>(6)</sup>	<b>2N6438</b> <sup>(6)</sup>	30/120	10	1	0.25	10	40	200
	140	2N6340		30/120	10	1	0.25	10	40	200
	150	<b>2N6341</b>		30/120	10	1	0.25	10	40	200
30	40	<b>2N3771</b>		15/60	15				2	150
		2N5301	2N4398	15/60	15	2	1	10	2	200
	60	<b>2N5302</b>	<b>2N4399</b>	15/60	15	2	1	10	2	200
		MJ11012 <sup>(2)</sup>	MJ11011 <sup>(2)</sup>	1k min	20				4 <sup>(1)</sup>	200
	90	<b>BUX39</b>		8 min	20	1	0.25	20	8	120
		<b>MJ11014</b> <sup>(2)</sup>	<b>MJ11013</b> <sup>(2)</sup>	1k min	20				4 <sup>(1)</sup>	200
	100	<b>2N6328</b>		6/30	30				3	200
		<b>MJ802</b>	<b>MJ4502</b>	25/100	7.5				2	200
	120	<b>MJ11016</b> <sup>(2)</sup> <sup>(6)</sup>	<b>MJ11015</b> <sup>(2)</sup> <sup>(6)</sup>	1k min	20				4 <sup>(1)</sup>	200
	325	<b>BUV23</b>		8 min	16	1.8	0.4	16	8	250
	400/1000	<b>BUS98</b>		8 min	20	2.3	0.4	20		250
		<b>BUX98</b>		8 min	20	3	0.8	20		250
	450/850	<b>MJ1602A</b> <sup>(16)</sup>		5 min	30	1.8	0.2	20		250
		<b>MJ1602A</b> <sup>(16)</sup>		7 min	30	1.5	0.15	20		250
	450/1000	<b>BUS98A</b>		8 min	16	2.3	0.4	16		250
<b>BUX98A</b>			8 min	16	3	0.8	16		250	
40	200	<b>BUV21</b> <sup>(16)</sup>		10 min	25	1.8	0.4	25	8	150
	250	<b>BUV22</b> <sup>(16)</sup>		10 min	20	1.1	0.35	20	8	250
	350	<b>MJ10022</b> <sup>(2)</sup> <sup>(16)</sup>		50/600	10	2.5	0.9	20		250
	400	<b>MJ10023</b> <sup>(2)</sup> <sup>(16)</sup>		50/600	10	2.5	0.9	20		250
50	60	<b>2N5685</b> <sup>(16)</sup>	<b>2N5683</b> <sup>(16)</sup>	15/60	25	0.5 typ	0.3 typ	25	2	300
		MJ11028 <sup>(2)</sup> <sup>(16)</sup>	MJ11029 <sup>(2)</sup> <sup>(16)</sup>	400 min	50					300
	80	<b>2N5686</b> <sup>(16)</sup>	<b>2N5684</b> <sup>(16)</sup>	15/60	25	0.5 typ	0.3 typ	25	2	300
	90	<b>MJ11030</b> <sup>(2)</sup> <sup>(16)</sup>	<b>MJ11031</b> <sup>(2)</sup> <sup>(16)</sup>	400 min	50					300
	100	<b>2N6274</b> <sup>(16)</sup>	<b>2N6378</b> <sup>(16)</sup>	30/120	20	0.8	0.25	20	30	250
	120	<b>2N6275</b> <sup>(16)</sup>	<b>2N6379</b> <sup>(16)</sup>	30/120	20	0.8	0.25	20	30	250
		<b>MJ11032</b> <sup>(2)</sup> <sup>(16)</sup>	<b>MJ11033</b> <sup>(2)</sup> <sup>(16)</sup>	400 min	50					300
	125	<b>BUV20</b> <sup>(16)</sup>		10 min	50	1.2	0.25	50	8	250
		<b>BUV60</b> <sup>(16)</sup>		10 min	80	1.1	0.25	80		250

(1)h<sub>FE</sub> @ 1 MHz

(2)Darlington

(6)Available as preferred chip.

(8)When 2 voltages are given, the format is V<sub>CEO(sus)</sub>/V<sub>CES</sub>.

(16)Case 197A-03 (TO-204AE)

Devices listed in bold, italic are Motorola preferred devices.

5

Table 8. Metal TO-204AA (Formerly TO-3), TO-204AE (continued) (continued)

I <sub>C</sub> Cont Amps Max	V <sub>CEO(sus)</sub> Volts Min <sup>(8)</sup>	Device Type		h <sub>FE</sub> Min/Max	@ I <sub>C</sub> Amp	Resistive Switching			f <sub>T</sub> MHz Min	P <sub>D</sub> (Case) Watts @ 25°C
		NPN	PNP			t <sub>s</sub> μs Max	t <sub>f</sub> μs Max	@ I <sub>C</sub> Amp		
50	150	<b>2N6277</b> <sup>(16)</sup>		30/120	20	0.8	0.25	20	30	250
	400	<b>MJ10015</b> <sup>(2)(16)</sup>		10 min	40	2.5	1	20		250
	500	<b>BUT34</b> <sup>(2)(16)</sup>		15 min	32	3	1.5	32		250
		<b>MJ10016</b> <sup>(2)(16)</sup>		10 min	40	2.5	1	20		250
56	400	<b>BUT33</b> <sup>(2)(16)</sup>		20 min	36	3.3	1.6	36		250
60	60	MJ14000 <sup>(16)</sup>	MJ14001 <sup>(16)</sup>	15/100	50					300
	80	<b>MJ14002</b> <sup>(16)</sup>	<b>MJ14003</b> <sup>(16)</sup>	15/100	50					300
	200	<b>MJ10020</b> <sup>(2)(16)</sup>		75 min	15	3.5	0.5	30		250
	250	<b>MJ10021</b> <sup>(2)(16)</sup>		75 min	15	3.5	0.5	30		250
70	125	<b>BUS50</b> <sup>(16)</sup>		15 min	50	1.5	0.3	70		350
80	100	<b>BUV18A</b> <sup>(16)</sup>		10 min	80	1.1	0.25	80		250

<sup>(2)</sup>Darlington

<sup>(8)</sup>When 2 voltages are given, the format is V<sub>CEO(sus)</sub>/V<sub>CES</sub>

<sup>(16)</sup>Case 197A-03 (TO-204AE)

Devices listed in bold, italic are Motorola preferred devices.

# Audio

## GENERAL DESIGN CURVES FOR POWER AUDIO OUTPUT STAGES

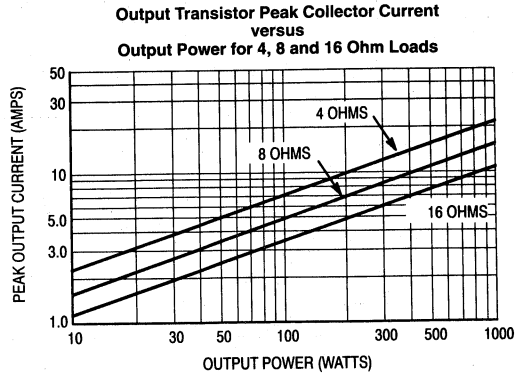
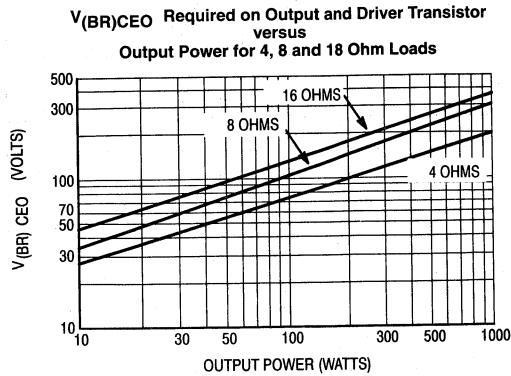

Another important parameter that must be considered before selecting the output transistors is the safe-operating area these devices must withstand. For a complete discussion on these see Application Notes AN484A and AN485.

**Table 9. Recommended Power Transistors for Audio/Servo Loads**

RMS Power Output	NPN	PNP	Case	$P_D$ Watts @ 25°C	$V_{CEO}$	$h_{FE}$ @ Min/Max	$I_C$ Amps	$f_T$ MHz Typ	ISB Volts/Amps
To 25W	MJE15030	MJE15031	TO-220	50	150	20 min	4	70	14/3.6
25 to 50W	2N3055A	MJ2955A	TO-204	120	120	20/70	4	3	60/2
	MJ15001	MJ15002	TO-204	200	140	25/150	4	3	40/5
50 to 100W	MJ15015	MJ15016	TO-204	180	120	20/70	4	3	60/3
	MJ15003	MJ15004	TO-204	250	140	25/150	5	3	100/1
	MJ15020	MJ15021	TO-204	150	250	30 min	1	20	50/3
Over 100W	MJ15024	MJ15025	TO-204	250	250	15/60	8	8	80/2.2
	MJ3281A	MJ1302A	TO-204	250	200	60/175	0.1	30	50/4
	MJL3281A	MJL1302A	340G-01	150	200	60/175	0.1	30	40/4
	MJ21193	MJ21194	TO-204	250	250	25/75	8	7	100/2
	MJL21193	MJL21194	340G-01	200	200	25/75	8	7	100/2

The Power Transistors shown are provided for reference only and show device capability. The final choice of the Power Transistors used is left to the circuit designer and depends upon the particular safe-operating area required and the mounting and heat sinking configuration used.

5

## CRT Deflection

A new family of SCANSWITCH™ bipolar power transistors, containing state-of-the-art application specific die, and a series of damper diodes have been designed for high and very high resolution horizontal deflection circuits. The horizontal output transistors minimize fall time, storage time and dynamic desaturation; turn-off energy is specified for optimum design considerations. The power rectifiers, designed for use as damper diodes in horizontal deflection circuits, are enhanced for turn-on overshoot voltage and forward recovery time. Overall circuit performance is optimized when these damper diodes are paired with their specific horizontal output transistors.

### Dynamic Desaturation

A large amount of power dissipation in horizontal deflection output circuitry occurs during the transistor's turn-off. Most of this dissipation happens as the collector-emitter voltage rises during storage time. Since there is a tendency for the voltage waveform to be soft and rounded as opposed to abrupt and square. The parameter used to describe this behavior is dynamic desaturation and is shown in Figure A as the area below the dashed line. The SCANSWITCH series of transistors has been designed to minimize dynamic desaturation and simultaneously avoid collector current tailing.

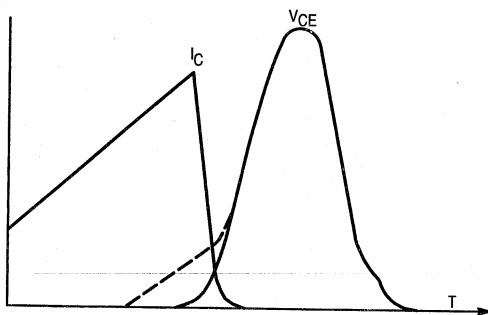

Figure A. Dynamic Desaturation

### Optimized Base Drive

The base drive can be optimized to take full advantage of the advanced device design of the SCANSWITCH series of transistors. The five conditions necessary for optimization are:

- 1) Provide adequate drive just prior to turn-off to minimize dynamic desaturation.
- 2) Avoid overdrive during any portion of the turn-on time to avoid collector current tailing.
- 3) Provide reverse base current that is independent of forward base current so full transistor performance can be realized.
- 4) Provide for a controlled rate of transition from forward to reverse drive to avoid tailing.
- 5) Avalanche the base-emitter junction during fall time.

Typical techniques for driving horizontal outputs use a base drive waveform which results in overdrive at turn-on and underdrive just prior to turn-off. An optimized base drive is one with the same forced gain throughout the turn-on period. A comparison of the two drives is shown in Figure B.

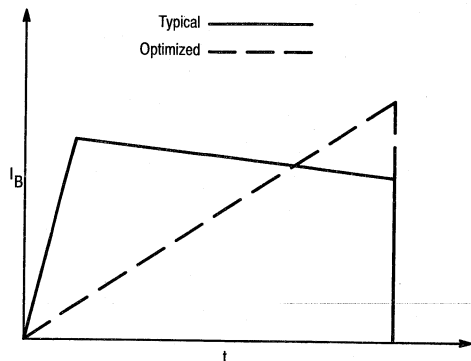

Figure B. Base Drive Comparison

## CRT Deflection (continued)

**Table 10. Horizontal CRT Deflection Transistor Selector Guide**

Monitor Description	Horizontal Scan Freq.	CRT Size	Pixel Size	Transistor	Diode
<b>Monochrome</b>					
Low Resolution to Mid Resolution	15–50 kHz	12–15 in.	>1024 x 768	MJE/MJF16204	MUR860E
High Resolution	50–100 kHz	15–19 in.	>2000 x 1600	MJW16206 MJW16210 MJW16212	MR/MUR10120E MR/MUR10120E MR/MUR10150E
Ultra-High Resolution	>100 kHz	19–24 in.	>2000 x 2000	MJL16218	MR/MUR10150E
<b>Color</b>					
Low Resolution	15–22 kHz	12–15 in.	>320 x 200	BU508A	MUR5150E
Mid Resolution	22–50 kHz	12–15 in.	>1024 x 768	BU508A	MUR5150E
High Resolution	50–90 kHz	17–27 in.	>1280 x 1024	MJW16206 MJW16210 MJW16212	MR/MUR10120E MR/MUR10120E MR/MUR10150E
Ultra-High Resolution	>90 kHz	17–27 in.	>1600 x 1280	MJW16210 <sup>(17)</sup> MJL16218	MUR8100E <sup>(17)</sup> MR/MUR10150E

(15) To be introduced.  
(17) Use two in parallel.

5

# Rectifiers

## In Brief . . .

Continuing investment in research and development for discrete products has created a rectifier manufacturing facility that matches the precision and versatility of the most advanced integrated circuits. As a result, Motorola's silicon rectifiers span all high tech applications with quality levels capable of passing the most stringent environmental tests . . . including those for automotive under-hood applications.

### Product Highlights:

- Surface Mount Devices — A major thrust has been the development and introduction of a broad range of power rectifiers, Schottky and Ultrafast, 1/2 amp to 25 amp, 15 to 600 volts.
- Application Specific Rectifiers —
  - MEGAHERTZ™ series for high frequency power supplies and power factor correction.
  - Schottky rectifiers having lower forward voltage drop (0.3 to 0.6 volts) for use in low voltage SMPS outputs and as "OR"ing diodes.
  - Automotive transient suppressors.
- Ultrafast rectifiers having reverse recovery times as low as 25 ns to complement the Schottky devices for higher voltage requirements in high frequency applications.
- A wide variety of package options to match virtually any potential requirement.

The rectifier selector section that follows has generally been arranged by package and technology. The individual tables have been sorted by voltage and current with the package types for the devices listed shown above each table. The Application Specific Rectifiers are also included in their respective tables.

Motorola's commitment to Six-Sigma is showing its worth. Refined processes no longer produce fallout as such and therefore only **Motorola Preferred Devices** are listed in the tables. The non-preferred devices will continue to be offered, but customers are encouraged to begin designing using the preferred types.

	<b>Page</b>
Rectifier Numbering System . . . . .	5.6-2
Application Specific Rectifiers . . . . .	5.6-3
Low V <sub>F</sub> Schottky . . . . .	5.6-3
MEGAHERTZ . . . . .	5.6-3
SCANSWITCH . . . . .	5.6-3
Automotive Transient Suppressors . . . . .	5.6-3
SWITCHMODE™ Rectifiers . . . . .	5.6-4
Surface Mount Schottky . . . . .	5.6-4
Axial Lead Schottky . . . . .	5.6-6
TO-220 Type Schottky . . . . .	5.6-7
TO-218 Types and TO-247 Schottky . . . . .	5.6-8
TO-204AA, DO-203AA and DO-203AB Schottky Metal Packages . . . . .	5.6-9
POWERTAP II and SOT-227B Schottky . . . . .	5.6-10
Ultrafast Rectifiers . . . . .	5.6-11
Surface Mount Ultrafast . . . . .	5.6-11
Axial Lead Ultrafast . . . . .	5.6-11
TO-220 Type Ultrafast . . . . .	5.6-12
TO-218 Types and TO-247 Ultrafast . . . . .	5.6-13
POWERTAP II and SOT-227B Ultrafast . . . . .	5.6-13
Fast Recovery Rectifiers/General Purpose Rectifiers . . . . .	5.6-14

5



# RECTIFIER NUMBERING SYSTEM

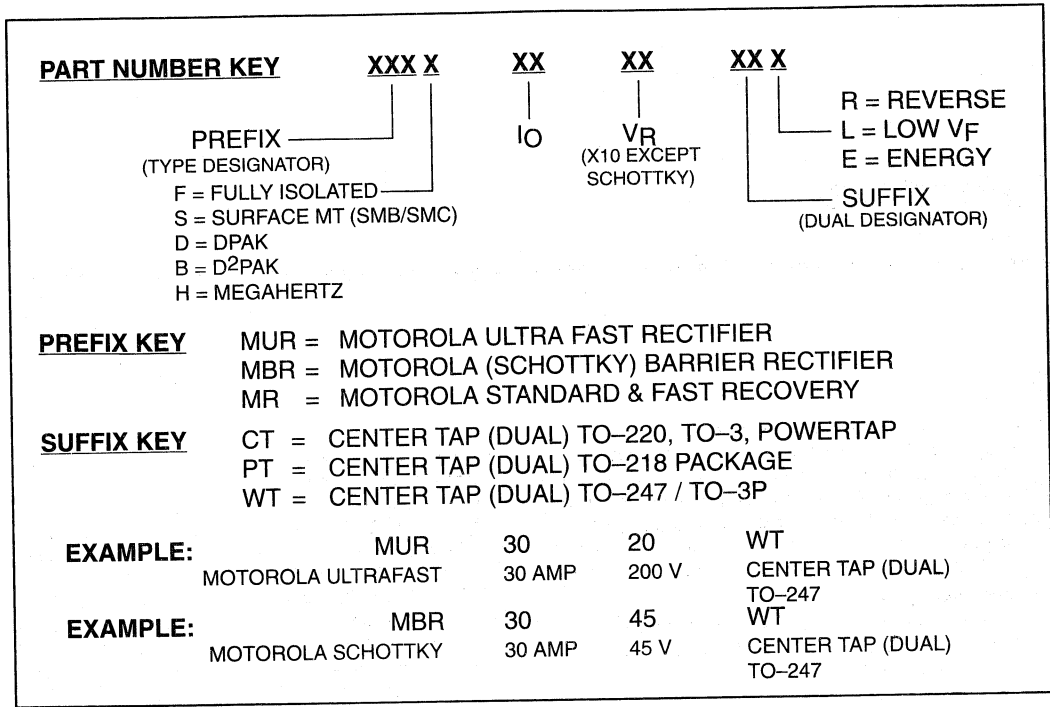

5

# Application Specific Rectifiers

The focus for Rectifier Products continues to be on Schottky and Ultrafast technologies, with process and packaging improvements to achieve greater efficiency in high frequency switching power supplies, and high current

mainframe supplies. Our new product thrust is intended to be more "application specific" than in the past, while continuing to strive for broad market acceptance.

**Table 1. Low  $V_F$  Schottky Rectifiers**

State of the art geometry is used in low  $V_F$  Schottky devices for improved efficiency in low voltage, high frequency switching power supplies, free-wheeling diodes, polarity protection diodes and "OR"ing diodes.

Device	$I_O$ Amps	$V_{RRM}$ (Volts)	$V_F$ @ Rated $I_O$ and Temperature Volts (Max)	$I_R$ @ Rated $V_{RRM}$ mAmps (Max)	Package
<b>MBR0520L</b>	0.5	20	0.33	0.25	SOD-123
<b>MBRS130LT3</b>	1	30	0.395	1	SMB
<b>MBRB3030CTL</b>	30	30	0.58	5	D <sup>2</sup> PAK
<b>MBRB2535CTL</b>	25	35	0.41	10	D <sup>2</sup> PAK
<b>MBR2535CTL</b>	25	35	0.41	5	TO-220
<b>MBR/MBRB2515L</b>	25	15	0.42	15	TO-220/D <sup>2</sup> PAK
<b>MBR6030L</b>	60	30	0.38	50	DO-203AB
<b>MBRP20030CTL</b>	200	30	0.39	5	POWERTAP
<b>MBRP60035CTL</b>	600	35	0.50	10	POWERTAP

**Table 2. MEGAHERTZ Rectifiers**

MEGAHERTZ Series — This group of ultrafast rectifiers is designed to provide improved efficiency in very high frequency switching power supplies and for use in power factor correction circuits.

Device	$I_O$ Amps	$V_{RRM}$ (Volts)	Maximum		$t_{rr}$ (Nanosecond)
			$V_F$ @ Rated $I_O$ and Temp. (Volts)	$I_R$ @ Rated $V_{RRM}$ (mAmps)	
<b>MURH840CT</b>	8	400	1.7	0.01	28
<b>MURH860CT</b>	8	600	2.0	0.01	28

5

**Table 3. SCANSWITCH Rectifiers**

These ultrafast rectifiers are designed for improved performance in very high resolution monitors and work stations where forward recovery time ( $t_{fr}$ ) and high voltage (1200–1500 volts) are primary considerations.

Device	$I_O$ Amps	$V_{RRM}$ (Volts)	Maximum		$V_{RFM}^{(6)}$ (Volts)
			$t_{fr}$ (Nanoseconds)	$t_{rr}$ (Nanoseconds)	
<b>MUR5150E</b>	5	1500	225	175	20
<b>MUR880E</b>	8	800	—	75	—
<b>MUR10120E</b>	10	1200	175	175	14
<b>MUR10150E</b>	10	1500	175	175	16
<b>MR10120E</b>	10	1200	175	1000	14
<b>MR10150E</b>	10	1500	175	1000	16

**Table 4. Automotive Transient Suppressors**

Automotive transient suppressors are designed for protection against over-voltage conditions in the auto electrical system including the "LOAD DUMP" phenomenon that occurs when the battery open circuits while the car is running.

Device	$I_O$ Amps	$V_{RRM}$ (Volts)	$V_{(BR)}$ (Volts)	$I_{RSM}^{(7)}$ (Amps)	T (°C)
<b>MR2535L</b>	35	20	24–32	110	175

(5) Schottky barrier device.

(6)  $V_{RFM}$  = Maximum Transient Overshoot Voltage.

(7) Time constant = 10 ms, Duty Cycle ≤ 1%,  $T_C = 25^\circ\text{C}$ .

Devices listed in bold, italic are Motorola preferred devices.

# SWITCHMODE™ Rectifiers

Schottky power rectifiers with the high speed and low forward voltage drop characteristic of Schottky's metal/silicon junctions are produced with ruggedness and temperature performance comparable to silicon-junction rectifiers. Ideal for use in low-voltage, high-frequency power supplies, and as very fast clamping diodes, these devices feature switching times less than 10 ns, and are offered in current ranges from 0.5 to 600 amperes, and reverse voltages to 200 volts.

In some current ranges, devices are available with junction temperature specifications of 125°C, 150°C and 175°C. Devices with higher T<sub>J</sub> ratings can have significantly lower leakage currents, but higher forward-voltage specifications. These parameter tradeoffs should be considered when selecting devices for applications that can be satisfied by more than one device type number.

All devices are connected cathode-to-case or cathode-to-heatsink, where applicable. Contact your Motorola representative for more information.

There are many other standard features in Motorola Schottky rectifiers that give added performance and reliability.

1. GUARDRINGS were pioneered by Motorola and are included in all Schottky die for reverse voltage stress protection from high rates of dv/dt to virtually eliminate the need for snubber networks. The guarding also operates like a zener and avalanches when subjected to voltage transients.
2. MOLYBDENUM DISCS on both sides of the die minimize fatigue from power cycling in all metal products. Plastic encapsulated devices have a special solder formulation for the same purpose.
3. QUALITY CONTROL monitors all critical fabrication operations and performs selected stress tests to assure constant processes. Motorola's commitment to six sigma has provided significant quality improvement.

Case 425  
SOD-12  
3



Cathode = Notch

Case 403A  
SMB



Cathode = Notch

Case 403  
SMC



Cathode = Notch

5

Table 5. Surface Mount Schottky Rectifiers

V <sub>RRM</sub> (Volts)	I <sub>O</sub> <sup>(1)</sup> (Amperes)	I <sub>O</sub> Rating Condition	Device	Max V <sub>F</sub> @ i <sub>F</sub> T <sub>C</sub> = 25°C (Volts)	I <sub>FSM</sub> (Amperes)	T <sub>J</sub> Max (°C)	Package
20	0.5	T <sub>L</sub> = 105°C	<b>MBR0520L</b> *	0.310 @ 0.1 A 0.385 @ 0.5 A	5	125	SOD-123
30	0.5	T <sub>L</sub> = 105°C	<b>MBR0530</b> *	0.375 @ 0.1 A 0.430 @ 0.5 A	5	125	SOD-123
40	0.5	T <sub>L</sub> = 110°C	<b>MBR0540</b> *	0.53 @ 0.5 A	20	150	SOD-123
30	1	T <sub>L</sub> = 120°C	<b>MBRS130LT3</b>	0.395 @ 1.0 A	40	125	SMB
40	1	T <sub>L</sub> = 115°C	<b>MBRS140T3</b>	0.6 @ 1.0 A	40	125	SMB
100	1	T <sub>L</sub> = 120°C	<b>MBRS1100T3</b>	0.75 @ 1.0 A	40	150	SMB
40	3	T <sub>L</sub> = 100°C	<b>MBRS340T3</b>	0.525 @ 3.0 A	80	125	SMC
60	3	T <sub>L</sub> = 100°C	<b>MBRS360T3</b> *	0.74 @ 3.0 A	80	125	SMC

(1) I<sub>O</sub> is total device current capability.

\* New Product

Devices listed in bold, italic are Motorola preferred devices.

Case 369A  
DPAK  
Style 3



Case 418B  
D<sup>2</sup>PAK  
Style 3



"CT" Suffix:



Non-"CT" Suffix:



Table 5. Surface Mount Schottky Rectifiers (continued)

V <sub>RRM</sub> (Volts)	I <sub>O</sub> (1) (Amperes)	I <sub>O</sub> Rating Condition	Device	Max V <sub>F</sub> @ I <sub>F</sub> T <sub>C</sub> = 25°C (Volts)	I <sub>FSM</sub> (Amperes)	T <sub>J</sub> Max (°C)	Package
40	3	T <sub>C</sub> = 125°C	<b>MBRD340</b>	0.60 @ 3.0 A	75	150	DPAK
60	3	T <sub>C</sub> = 125°C	<b>MBRD360</b>	0.60 @ 3.0 A	75	150	DPAK
40	6	T <sub>C</sub> = 130°C	<b>MBRD640CT</b>	0.70 @ 3.0 A	75	150	DPAK
60	6	T <sub>C</sub> = 130°C	<b>MBRD660CT</b>	0.70 @ 3.0 A	75	150	DPAK
35	8	T <sub>C</sub> = 100°C	<b>MBRD835L</b> *	0.40 @ 3.0 A 0.51 @ 8.0 A	100	125	DPAK
35	10	T <sub>C</sub> = 90°C	<b>MBRD1035CTL</b> *	0.49 @ 10 A	100	125	DPAK
45	15	T <sub>C</sub> = 105°C	<b>MBRB1545CT</b>	0.84 @ 15 A	150	150	D <sup>2</sup> PAK
60	20	T <sub>C</sub> = 110°C	<b>MBRB2060CT</b>	0.95 @ 20 A	150	150	D <sup>2</sup> PAK
100	20	T <sub>C</sub> = 110°C	<b>MBRB20100CT</b>	0.85 @ 10 A 0.95 @ 20 A	150	150	D <sup>2</sup> PAK
200	20	T <sub>C</sub> = 125°C	<b>MBRB20200CT</b> *	1.0 @ 20 A	150	150	D <sup>2</sup> PAK
15	25	T <sub>C</sub> = 90°C	<b>MBRB2515L</b> *	0.45 @ 25 A	150	100	D <sup>2</sup> PAK
35	25	T <sub>C</sub> = 110°C	<b>MBRB2535CTL</b>	0.47 @ 12.5 A 0.55 @ 25 A	150	125	D <sup>2</sup> PAK
45	25	T <sub>C</sub> = 130°C	<b>MBRB2545CT</b>	0.82 @ 30 A	150	150	D <sup>2</sup> PAK
30	30	T <sub>C</sub> = 115°C	<b>MBRB3030CT</b> *	0.51 @ 15 A 0.62 @ 30 A	300	150	D <sup>2</sup> PAK
30	30	T <sub>C</sub> = 95°C	<b>MBRB3030CTL</b> *	0.58 @ 30 A	150	125	D <sup>2</sup> PAK
30	40	T <sub>C</sub> = 110°C	<b>MBRB4030</b> *	0.53 @ 40 A	300	150	D <sup>2</sup> PAK

(1) I<sub>O</sub> is total device current capability.

\* New Product

5

Devices listed in bold, italic are Motorola preferred devices.



Cathode = Polarity Band



Cathode = Polarity Band



Table 6. Axial Lead Schottky Rectifiers

V <sub>RRM</sub> (Volts)	I <sub>O</sub> (Amperes)	I <sub>O</sub> Rating Condition	Device	Max V <sub>F</sub> @ I <sub>F</sub> T <sub>C</sub> = 25°C (Volts)	I <sub>FSM</sub> (Amperes)	T <sub>J</sub> Max (°C)	Case
20	1	T <sub>A</sub> = 55°C R <sub>θJA</sub> = 80°C/W	<b>1N5817</b>	0.45 @ 1.0 A	25	125	59-04
30	1	T <sub>A</sub> = 55°C R <sub>θJA</sub> = 80°C/W	<b>1N5818</b>	0.55 @ 1.0 A	25	125	59-04
40	1	T <sub>A</sub> = 55°C R <sub>θJA</sub> = 80°C/W	<b>1N5819</b>	0.60 @ 1.0 A	25	125	59-04
60	1	T <sub>A</sub> = 55°C R <sub>θJA</sub> = 80°C/W	<b>MBR160</b>	0.75 @ 1.0 A	25	150	59-04
100	1	T <sub>A</sub> = 120°C R <sub>θJA</sub> = 50°C/W	<b>MBR1100</b>	0.79 @ 1.0 A	50	150	59-04
20	3	T <sub>A</sub> = 76°C R <sub>θJA</sub> = 28°C/W	<b>1N5820</b>	0.457 @ 3.0 A	80	125	267-03
30	3	T <sub>A</sub> = 71°C R <sub>θJA</sub> = 28°C/W	<b>1N5821</b>	0.500 @ 3.0 A	80	125	267-03
40	3	T <sub>A</sub> = 61°C R <sub>θJA</sub> = 28°C/W	<b>1N5822</b>	0.525 @ 3.0 A	80	125	267-03
40	3	T <sub>A</sub> = 65°C R <sub>θJA</sub> = 28°C/W	<b>MBR340</b>	0.600 @ 3.0 A	80	150	267-03
60	3	T <sub>A</sub> = 65°C R <sub>θJA</sub> = 28°C/W	<b>MBR360</b>	0.740 @ 3.0 A	80	150	267-03
100	3	T <sub>A</sub> = 100°C R <sub>θJA</sub> = 28°C/W	<b>MBR3100</b>	0.79 @ 3.0 A	150	150	267-03
20	5	T <sub>A</sub> = 30°C R <sub>θJA</sub> = 25°C/W	<b>1N5823</b>	0.360 @ 5.0 A	500	125	60-01
30	5	T <sub>A</sub> = 40°C R <sub>θJA</sub> = 25°C/W	<b>1N5824</b>	0.370 @ 5.0 A	500	125	60-01
40	5	T <sub>A</sub> = 45°C R <sub>θJA</sub> = 25°C/W	<b>1N5825</b>	0.380 @ 5.0 A	500	125	60-01

5

Devices listed in bold, italic are Motorola preferred devices.

Case 221B  
(TO-220AC)

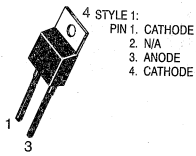

Case  
221A-06  
(TO-220AB)

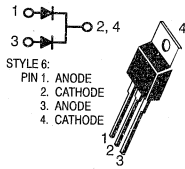

Case 221E

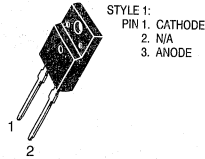

Case 221D

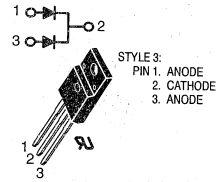

Table 7. TO-220 Type Schottky Rectifiers

V <sub>RRM</sub> (Volts)	I <sub>O</sub> (Amperes)	I <sub>O</sub> Rating Condition	Device	Max V <sub>F</sub> @ I <sub>F</sub> T <sub>C</sub> = 25°C (Volts)	I <sub>FSM</sub> (Amperes)	T <sub>J</sub> Max (°C)	Case
45	15	T <sub>C</sub> = 105°C	<i>MBR1545CT</i>	0.84 @ 15 A	150	150	221A-06
30	20	T <sub>C</sub> = 137°C	<i>MBR2030CTL</i> ★	0.52 @ 10 A 0.58 @ 20 A	150	150	221A-06
45	20	T <sub>C</sub> = 135°C	<i>MBR2045CT</i>	0.84 @ 20 A	150	150	221A-06
60	20	T <sub>C</sub> = 133°C	<i>MBR2060CT</i>	0.85 @ 10 A 0.95 @ 20 A	150	150	221A-06
100	20	T <sub>C</sub> = 133°C	<i>MBR20100CT</i>	0.85 @ 10 A 0.95 @ 20 A	150	150	221A-06
200	20	T <sub>C</sub> = 125°C	<i>MBR20200CT</i>	1.0 @ 20 A	150	150	221A-06
15	25	T <sub>C</sub> = 90°C	<i>MBR2515L</i> ★	0.45 @ 25 A	150	100	221A-06
35	25	T <sub>C</sub> = 95°C	<i>MBR2535CTL</i> ★	0.55 @ 25 A	150	125	221A-06
45	25	T <sub>C</sub> = 130°C	<i>MBR2545CT</i>	0.82 @ 30 A	150	150	221A-06
45	30	T <sub>C</sub> = 130°C	<i>MBR3045ST</i> ★	0.76 @ 30 A	150	150	221A-06
45	7.5	T <sub>C</sub> = 105°C	<i>MBR745</i>	0.84 @ 15 A	150	150	221B
45	10	T <sub>C</sub> = 135°C	<i>MBR1045</i>	0.84 @ 20 A	150	150	221B
60	10	T <sub>C</sub> = 133°C	<i>MBR1060</i>	0.80 @ 10 A	150	150	221B
100	10	T <sub>C</sub> = 133°C	<i>MBR10100</i>	0.80 @ 10 A	150	150	221B
45	16	T <sub>C</sub> = 125°C	<i>MBR1645</i>	0.63 @ 16 A	150	150	221B
45	15	T <sub>C</sub> = 105°C	⚡ <i>MBRF1545CT</i> ★	0.84 @ 15 A	150	150	ISOLATED 221D
45	20	T <sub>C</sub> = 135°C	⚡ <i>MBRF2045CT</i> ★	0.84 @ 20 A	150	150	ISOLATED 221D
60	20	T <sub>C</sub> = 133°C	⚡ <i>MBRF2060CT</i> ★	0.95 @ 20 A	150	150	ISOLATED 221D
100	20	T <sub>C</sub> = 133°C	⚡ <i>MBRF20100CT</i> ★	0.95 @ 20 A	150	150	ISOLATED 221D
200	20	T <sub>C</sub> = 125°C	⚡ <i>MBRF20200CT</i> ★	1.0 @ 20 A	150	150	ISOLATED 221D
45	25	T <sub>C</sub> = 125°C	⚡ <i>MBRF2545CT</i> ★	0.82 @ 25 A	150	150	ISOLATED 221D
45	7.5	T <sub>C</sub> = 105°C	<i>MBRF745</i> ★	0.84 @ 15 A	150	150	ISOLATED 221E
45	10	T <sub>C</sub> = 135°C	<i>MBRF1045</i> ★	0.84 @ 20 A	150	150	ISOLATED 221E

⚡ Indicates UL Recognized — File #E69369

★ New Product

Devices listed in bold, italic are Motorola preferred devices.

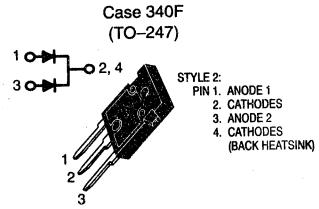
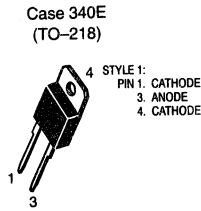
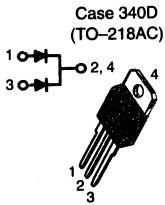

Table 8. TO-218 Types and TO-247 Schottky Rectifiers

V <sub>RRM</sub> (Volts)	I <sub>O</sub> (Amperes)	I <sub>O</sub> Rating Condition	Device	Max V <sub>F</sub> @ I <sub>F</sub> T <sub>C</sub> = 25°C (Volts)	I <sub>FSM</sub> (Amperes)	T <sub>J</sub> Max (°C)	Case
45	30	T <sub>C</sub> = 105°C	<b>MBR3045PT</b>	0.76 @ 30 A	200	150	340D
45	40	T <sub>C</sub> = 125°C	<b>MBR4045PT</b>	0.70 @ 20 A 0.80 @ 40 A	400	150	340D
45	60	T <sub>C</sub> = 125°C	<b>MBR6045PT</b> *	0.62 @ 30 A 0.75 @ 60 A	500	150	340D
100	30	T <sub>C</sub> = 130°C	<b>MBR30100</b> *	0.95 @ 30 A	300	150	340E
25	50	T <sub>C</sub> = 125°C	<b>MBR5025L</b> *	0.54 @ 30 A 0.62 @ 50 A	300	150	340E
45	30	T <sub>C</sub> = 105°C	<b>MBR3045WT</b>	0.76 @ 30 A	200	150	340F
15	40	T <sub>C</sub> = 125°C	<b>MBR4015LWT</b> *	0.42 @ 20 A 0.50 @ 40 A	400	150	340F
45	40	T <sub>C</sub> = 125°C	<b>MBR4045WT</b>	0.70 @ 20 A 0.80 @ 40 A	400	150	340F
45	60	T <sub>C</sub> = 125°C	<b>MBR6045WT</b> *	0.62 @ 30 A 0.75 @ 60 A	500	150	340F

\* New Product

5

Devices listed in bold, italic are Motorola preferred devices.

Case 56  
(DO-203AA)



STYLE 2:  
PIN 1: ANODE  
2: CATHODE (CASE)

Case 257  
(DO-203AB)



STYLE 2:  
PIN 1: ANODE  
2: CATHODE (CASE)

Case 11-03  
(TO-204AA)

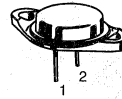

STYLE 4:  
PIN 1: ANODE #1  
2: ANODE #2  
CASE: COMMON CATHODE



Table 9. TO-204AA (formerly TO-3), DO-203AA and DO-203AB (formerly DO-4 and DO-5)  
Schottky Rectifier Metal Packages

V <sub>RRM</sub> (Volts)	I <sub>O</sub> (Amperes)	I <sub>O</sub> Rating Condition	Device	Max V <sub>F</sub> @ i <sub>F</sub> T <sub>C</sub> = 25°C (Volts)	I <sub>FSM</sub> (Amperes)	T <sub>J</sub> Max (°C)	Case
20	15	T <sub>C</sub> = 85°C (V <sub>R</sub> = 4 V)	<b>1N5826</b>	0.44 @ 15 A	500	125	56
30	15	T <sub>C</sub> = 85°C (V <sub>R</sub> = 6 V)	<b>1N5827</b>	0.47 @ 15 A	500	125	56
40	15	T <sub>C</sub> = 85°C (V <sub>R</sub> = 8 V)	<b>1N5828</b>	0.50 @ 15 A	500	125	56
20	25	T <sub>C</sub> = 85°C (V <sub>R</sub> = 4 V)	<b>1N5829</b>	0.44 @ 25 A	800	125	56
30	25	T <sub>C</sub> = 85°C (V <sub>R</sub> = 6 V)	<b>1N5830</b>	0.46 @ 25 A	800	125	56
40	25	T <sub>C</sub> = 85°C (V <sub>R</sub> = 8 V)	<b>1N5831</b>	0.48 @ 25 A	800	125	56
30	25	T <sub>C</sub> = 70°C	<b>1N6095</b>	0.86 @ 78.5 A T <sub>C</sub> = 70°C	400	125	56
40	25	T <sub>C</sub> = 70°C	<b>1N6096</b>	0.86 @ 78.5 A T <sub>C</sub> = 70°C	400	125	56
45	30	T <sub>C</sub> = 105°C	<b>SD41</b>	0.55 @ 78.5 A T <sub>C</sub> = 125°C	600	150	56
45	35	T <sub>C</sub> = 110°C	<b>MBR3545</b>	0.63 @ 35 A	600	150	56
20	40	T <sub>C</sub> = 75°C (V <sub>R</sub> = 4 V)	<b>1N5832</b>	0.052 @ 40 A	800	125	257
30	40	T <sub>C</sub> = 75°C (V <sub>R</sub> = 6 V)	<b>1N5833</b>	0.55 @ 40 A	800	125	257
40	40	T <sub>C</sub> = 75°C (V <sub>R</sub> = 8 V)	<b>1N5834</b>	0.59 @ 40 A	800	125	257
30	50	T <sub>C</sub> = 70°C	<b>1N6097</b>	0.86 @ 157 A T <sub>C</sub> = 70°C	800	125	257
40	50	T <sub>C</sub> = 70°C	<b>1N6098</b>	0.86 @ 157 A T <sub>C</sub> = 70°C	800	125	257
30	60	T <sub>C</sub> = 120°C	<b>MBR6030L</b>	0.42 @ 30 A 0.48 @ 60 A	1000	150	257
45	60	T <sub>C</sub> = 90°C	<b>SD51</b>	0.70 @ 60 A	800	150	257
45	60	T <sub>C</sub> = 100°C	<b>MBR6045</b>	0.70 @ 60 A	800	150	257
45	65	T <sub>C</sub> = 120°C	<b>MBR6545</b>	0.78 @ 65 A	800	175	257
45	75	T <sub>C</sub> = 90°C	<b>MBR7545</b>	0.60 @ 60 A T <sub>C</sub> = 125°C	1000	150	257
45	80	T <sub>C</sub> = 120°C	<b>MBR8045</b>	0.72 @ 80 A	1000	175	257
45	30	T <sub>C</sub> = 105°C	<b>MBR3045CT</b>	0.76 @ 30 A	400	150	11-03
45	30	T <sub>C</sub> = 105°C	<b>SD241</b>	0.60 @ 20 A T <sub>C</sub> = 125°C	400	150	11-03

5

Devices listed in bold, italic are Motorola preferred devices.



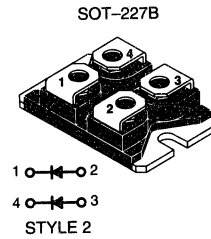
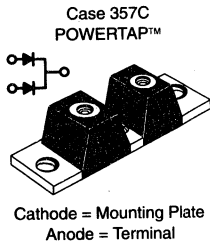

**Table 10. POWER TAP II and SOT-227B Schottky Rectifiers**

V <sub>RRM</sub> (Volts)	I <sub>O</sub> (1) (Amperes)	I <sub>O</sub> Rating Condition	Device	Max V <sub>F</sub> @ I <sub>F</sub> T <sub>C</sub> = 25°C (Volts)	I <sub>FSM</sub> (Amperes)	T <sub>J</sub> Max (°C)	Case
30	200	T <sub>C</sub> = 140°C	<b><i>MBRP20030CTL</i></b> *	0.46 @ 100 A 0.55 @ 200 A	1500	150	357C
45	200	T <sub>C</sub> = 140°C	<b><i>MBRP20045CT</i></b> *	0.800 @ 100 A	1500	175	357C
60	200	T <sub>C</sub> = 140°C	<b><i>MBRP20060CT</i></b> *	0.800 @ 100 A	1500	175	357C
45	300	T <sub>C</sub> = 140°C	<b><i>MBRP30045CT</i></b> *	0.74 @ 150 A 0.82 @ 300 A	2500	175	357C
60	300	T <sub>C</sub> = 140°C	<b><i>MBRP30060CT</i></b> *	0.74 @ 150 A 0.82 @ 300 A	2500	175	357C
35	600	T <sub>C</sub> = 100°C	<b><i>MBRP60035CTL</i></b> *	0.57 @ 300 A	4000	150	357C
100	80	T <sub>C</sub> = 125°C	<b><i>MBR240100V</i></b> *	0.95 @ 40 A	600	150	SOT-227B Style 2
60	100	T <sub>C</sub> = 125°C	<b><i>MBR25060V</i></b> *	0.65 @ 50 A	800	150	SOT-227B Style 2
45	160	T <sub>C</sub> = 125°C	<b><i>MBR28045V</i></b> *	0.80 @ 80 A 1.0 @ 160 A	900	150	SOT-227B Style 2

(1) I<sub>O</sub> is total device current capability.

All POWER TAP devices are being converted to the new, more rugged, POWER TAP II configuration beginning January 1994. Contact your Motorola representative for more details.

All SOT-227B devices have 2500 volts isolation between the heatsink and active elements.

\* New Product

5

Devices listed in bold, italic are Motorola preferred devices.

# Ultrafast Rectifiers



**Table 11. Surface Mount Ultrafast Rectifiers**

V <sub>RRM</sub> (Volts)	I <sub>O</sub> (1) (Amperes)	I <sub>O</sub> Rating Condition	Device	Max t <sub>rr</sub> (ns)	Max V <sub>F</sub> @ I <sub>F</sub> T <sub>C</sub> = 25°C (Volts)	I <sub>FSM</sub> (Amperes)	T <sub>J</sub> Max (°C)	Package
200	1	T <sub>L</sub> = 155°C	<i>MURS120T3</i>	35	0.875 @ 1.0 A	40	175	SMB
600	1	T <sub>L</sub> = 150°C	<i>MURS160T3</i>	75	1.25 @ 1.0 A	35	175	SMB
200	3	T <sub>L</sub> = 140°C	<i>MURS320T3</i>	35	0.875 @ 3.0 A	75	175	SMC
600	3	T <sub>L</sub> = 130°C	<i>MURS360T3</i>	75	1.25 @ 3.0 A	75	175	SMC
200	3	T <sub>L</sub> = 158°C	<i>MURD320</i>	35	0.95 @ 3.0 A	75	175	DPAK
200	6	T <sub>L</sub> = 145°C	<i>MURD620CT</i>	35	1.0 @ 3.0 A	63	175	DPAK
400	8	T <sub>L</sub> = 120°C	<i>MURHB840CT</i> *	28	2.2 @ 4.0 A	100	175	D2PAK
200	16	T <sub>L</sub> = 150°C	<i>MURB1620CT</i>	35	0.975 @ 8.0 A	100	175	D2PAK
600	16	T <sub>L</sub> = 150°C	<i>MURB1660CT</i>	60	1.5 @ 8.0 A	100	175	D2PAK

(1) I<sub>O</sub> is total device current capability.  
\* New Product

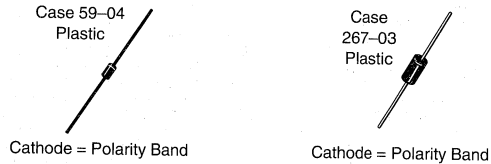

**Table 12. Axial Lead Ultrafast Rectifiers**

V <sub>RRM</sub> (Volts)	I <sub>O</sub> (Amperes)	I <sub>O</sub> Rating Condition	Device	Max t <sub>rr</sub> (ns)	Max V <sub>F</sub> @ I <sub>F</sub> T <sub>C</sub> = 25°C (Volts)	I <sub>FSM</sub> (Amperes)	T <sub>J</sub> Max (°C)	Case
200	1	T <sub>A</sub> = 130°C R <sub>θJA</sub> = 50°C/W	<i>MUR120</i>	25	0.875 @ 1.0 A	35	175	59-04
400	1	T <sub>A</sub> = 120°C R <sub>θJA</sub> = 50°C/W	<i>MUR140</i>	50	1.25 @ 1.0 A	35	175	59-04
600	1	T <sub>A</sub> = 120°C R <sub>θJA</sub> = 50°C/W	<i>MUR160</i>	50	1.25 @ 1.0 A	35	175	59-04
1000	1	T <sub>A</sub> = 95°C R <sub>θJA</sub> = 50°C/W	<i>MUR1100E</i>	75	1.75 @ 1.0 A	35	175	59-04
200	4	T <sub>A</sub> = 80°C R <sub>θJA</sub> = 28°C/W	<i>MUR420</i>	25	0.875 @ 3.0 A	125	175	267-03
400	4	T <sub>A</sub> = 40°C R <sub>θJA</sub> = 28°C/W	<i>MUR440</i>	50	1.25 @ 3.0 A	70	175	267-03
600	4	T <sub>A</sub> = 40°C R <sub>θJA</sub> = 28°C/W	<i>MUR460</i>	50	1.25 @ 3.0 A	70	175	267-03
1000	4	T <sub>A</sub> = 35°C R <sub>θJA</sub> = 28°C/W	<i>MUR4100E</i>	75	1.75 @ 3.0 A	70	175	267-03

Devices listed in bold, italic are Motorola preferred devices.

Case 221B  
(TO-220AC)



STYLE 1:  
PIN 1. CATHODE  
2. N/A  
3. ANODE  
4. CATHODE

Case 221A-06  
(TO-220AB)

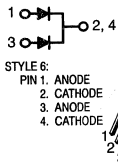

STYLE 6:  
PIN 1. ANODE  
2. CATHODE  
3. ANODE  
4. CATHODE



STYLE 7:  
PIN 1. CATHODE  
2. ANODE  
3. CATHODE  
4. ANODE

Case 221E



STYLE 1:  
PIN 1. CATHODE  
2. N/A  
3. ANODE

Case 221D

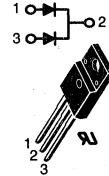

STYLE 3:  
PIN 1. ANODE  
2. CATHODE  
3. ANODE

Table 13. TO-220 Type Ultrafast Rectifiers

V <sub>RRM</sub> (Volts)	I <sub>O</sub> (Amperes)	I <sub>O</sub> Rating Condition	Device	Max t <sub>rr</sub> (ns)	Max V <sub>F</sub> @ I <sub>F</sub> T <sub>C</sub> = 25°C (Volts)	I <sub>FSM</sub> (Amperes)	T <sub>J</sub> Max (°C)	Case
200	6	T <sub>C</sub> = 130°C	<i>MUR620CT</i>	35	0.975 @ 3.0 A	75	175	221A-06
400	8	T <sub>C</sub> = 120°C	<i>MURH840CT</i>	28	2.0 @ 4.0 A	100	175	221A-06
600	8	T <sub>C</sub> = 120°C	<i>MURH860CT</i>	35	2.8 @ 4.0 A	100	175	221A-06
200	16	T <sub>C</sub> = 150°C	<i>MUR1620CT</i>	35	0.975 @ 8.0 A	100	175	221A-06
200	16	T <sub>C</sub> = 160°C	<i>MUR1620CTR</i>	85	1.2 @ 8.0 A	100	175	221A-06
400	16	T <sub>C</sub> = 150°C	<i>MUR1640CT</i>	60	1.30 @ 8.0 A	100	175	221A-06
600	16	T <sub>C</sub> = 150°C	<i>MUR1660CT</i>	60	1.5 @ 8.0 A	100	175	221A-06
1500	5	T <sub>C</sub> = 125°C	<i>MUR5150E</i>	175	2.4 @ 5.0 A	100	125	221B
200	8	T <sub>C</sub> = 150°C	<i>MUR820</i>	35	0.975 @ 8.0 A	100	175	221B
400	8	T <sub>C</sub> = 150°C	<i>MUR840</i> *	50	1.30 @ 8.0 A	100	175	221B
600	8	T <sub>C</sub> = 150°C	<i>MUR860</i> *	50	1.50 @ 8.0 A	100	175	221B
800	8	T <sub>C</sub> = 175°C	<i>MUR880E</i>	75	1.80 @ 8.0 A	100	175	221B
1000	8	T <sub>C</sub> = 150°C	<i>MUR8100E</i>	75	1.80 @ 8.0 A	100	175	221B
1200	10	T <sub>C</sub> = 125°C	<i>MUR10120E</i>	175	2.2 @ 6.5 A	100	125	221B
1200	10	T <sub>C</sub> = 125°C	<i>MR10120E</i>	1000	1.5 @ 6.5 A	100	125	221B
1500	10	T <sub>C</sub> = 125°C	<i>MUR10150E</i>	175	2.4 @ 6.5 A	100	125	221B
1500	10	T <sub>C</sub> = 125°C	<i>MR10150E</i>	1000	1.8 @ 6.5 A	100	125	221B
200	15	T <sub>C</sub> = 150°C	<i>MUR1520</i>	35	1.05 @ 15 A	200	175	221B
400	15	T <sub>C</sub> = 150°C	<i>MUR1540</i>	60	1.25 @ 15 A	150	175	221B
600	15	T <sub>C</sub> = 145°C	<i>MUR1560</i>	60	1.50 @ 15 A	150	175	221B
200	8	T <sub>C</sub> = 150°C	<i>MURF820</i> *	25	0.975 @ 8.0 A	100	150	ISOLATED 221E
1200	10	T <sub>C</sub> = 125°C	<i>MURF10120E</i> *	175	2.2 @ 6.5 A	100	125	ISOLATED 221E
1500	10	T <sub>C</sub> = 125°C	<i>MURF10150E</i> *	175	2.4 @ 6.5 A	100	125	ISOLATED 221E
200	16	T <sub>C</sub> = 150°C	<i>MURF1620CT</i> *	25	0.975 @ 8.0 A	100	150	ISOLATED 221D
600	16	T <sub>C</sub> = 150°C	<i>MURF1660CT</i> *	50	1.50 @ 8.0 A	100	150	ISOLATED 221D

UL Indicates UL Recognized — File #E69369

\* New Product

Devices listed in bold, italic are Motorola preferred devices.

5

Case 340D  
(TO-218AC)

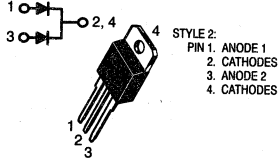

Case 340E  
(TO-218)

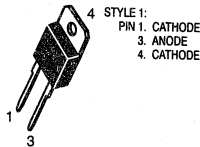

Case 340F  
(TO-247)

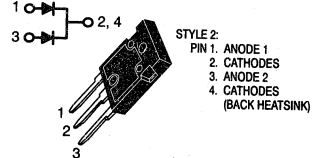
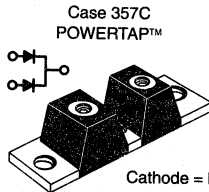

Table 14. TO-218 Types and TO-247 Ultrafast Rectifiers

V <sub>RRM</sub> (Volts)	I <sub>O</sub> (Amperes)	I <sub>O</sub> Rating Condition	Device	Max t <sub>rr</sub> (ns)	Max V <sub>F</sub> @ i <sub>F</sub> T <sub>C</sub> = 25°C (Volts)	I <sub>FSM</sub> (Amperes)	T <sub>J</sub> Max (°C)	Case
200	30	T <sub>C</sub> = 145°C	<b>MUR3020WT</b>	35	1.05 @ 15 A	150	175	340F
400	30	T <sub>C</sub> = 145°C	<b>MUR3040WT</b>	60	1.25 @ 15 A	150	175	340F
600	30	T <sub>C</sub> = 145°C	<b>MUR3060WT</b>	60	1.70 @ 15 A	150	175	340F
200	30	T <sub>C</sub> = 150°C	<b>MUR3020PT</b>	35	1.12 @ 15 A	200	175	340D
400	30	T <sub>C</sub> = 150°C	<b>MUR3040PT</b>	60	1.12 @ 15 A	150	175	340D
600	30	T <sub>C</sub> = 145°C	<b>MUR3060PT</b>	60	1.20 @ 15 A	150	175	340D
400	30	T <sub>C</sub> = 70°C	<b>MUR3040*</b>	100	1.5 @ 30 A	300	175	340E
600	30	T <sub>C</sub> = 70°C	<b>MUR3060*</b>	110	1.90 @ 30 A	300	175	340E
800	30	T <sub>C</sub> = 70°C	<b>MUR3080*</b>	110	1.90 @ 30 A	300	175	340E
400	60	T <sub>C</sub> = 70°C	<b>MUR6040</b>	100	1.50 @ 60 A	600	175	340E

\* New Product



SOT-227B

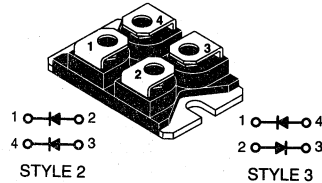

Table 15. POWER TAP II and SOT-227B Ultrafast Rectifiers

V <sub>RRM</sub> (Volts)	I <sub>O</sub> (1) (Amperes)	I <sub>O</sub> Rating Condition	Device	Max t <sub>rr</sub> (ns)	Max V <sub>F</sub> @ i <sub>F</sub> T <sub>C</sub> = 25°C (Volts)	I <sub>FSM</sub> (Amperes)	T <sub>J</sub> Max (°C)	Case
400	60	T <sub>C</sub> = 60°C	<b>BYT230PIV-400M*</b>	100	1.5 @ 30 A	200	150	SOT-227B Style 3
1000	60	T <sub>C</sub> = 50°C	<b>BYT230PIV-1000M*</b>	165	1.9 @ 30 A	200	150	SOT-227B Style 3
400	120	T <sub>C</sub> = 80°C	<b>BYT261PIV-400M*</b>	100	1.5 @ 60 A	600	150	SOT-227B Style 2
1000	120	T <sub>C</sub> = 60°C	<b>BYT261PIV-1000M*</b>	170	1.9 @ 60 A	400	150	SOT-227B Style 2
200	200	T <sub>C</sub> = 95°C	<b>MURP20020CT*</b>	50	1.25 @ 100 A	800	175	357C
400	200	T <sub>C</sub> = 95°C	<b>MURP20040CT*</b>	50	1.25 @ 100 A	800	175	357C

(1) I<sub>O</sub> is total device current capability.

All POWER TAP devices are being converted to the new, more rugged, POWER TAP II configuration beginning January 1994. Contact your Motorola representative for more details.

All SOT-227B devices have 2500 volts isolation between the heatsink and active elements.

\* New Product

Devices listed in bold, italic are Motorola preferred devices.

# Fast Recovery Rectifiers/General-Purpose Rectifiers

Axial lead Fast Recovery Rectifiers having maximum switching times of 200 ns and low cost general purpose rectifiers are listed in the table below.

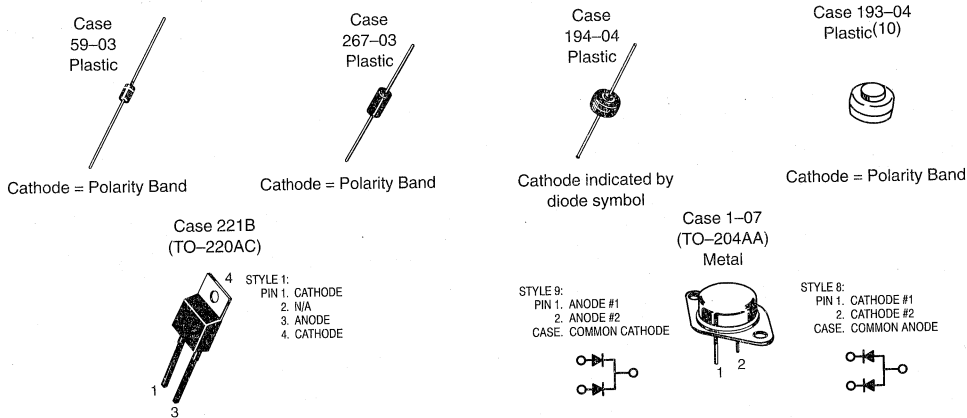

Table 16. Fast Recovery Rectifiers/General Purpose Rectifiers

V <sub>RRM</sub> (Volts)	I <sub>O</sub> (Amperes)	I <sub>O</sub> Rating Condition	Device	Max V <sub>F</sub> @ I <sub>F</sub> T <sub>J</sub> = 25°C (Volts)	Max t <sub>rr</sub> (ns)	I <sub>FSM</sub> (Amperes)	T <sub>J</sub> Max (°C)	Case
400	1	T <sub>A</sub> = 75°C	<b>1N4004</b>	1.1 @ 1.0 A	—	30	150	59-03 <sup>(3)</sup>
1000	1	T <sub>A</sub> = 75°C	<b>1N4007</b>	1.1 @ 1.0 A	—	30	150	59-03 <sup>(3)</sup>
200	1	T <sub>A</sub> = 75°C	<b>1N4935</b>	1.2 @ 3.14 A T <sub>J</sub> = 125°C	200	30	150	59-03 <sup>(3)</sup>
600	1	T <sub>A</sub> = 75°C	<b>1N4937</b>	1.2 @ 3.14 A T <sub>J</sub> = 125°C	200	30	150	59-03 <sup>(3)</sup>
400	3	T <sub>L</sub> = 105°C	<b>1N5404</b>	1.2 @ 9.4 A	—	200	150	267-03
600	3	T <sub>L</sub> = 105°C	<b>1N5406</b>	1.2 @ 9.4 A	—	200	150	267-03
200	3	T <sub>A</sub> = 80°C <sup>(8)</sup>	<b>MR852</b>	1.25 @ 3.0 A	200	100	150	267-03
600	3	T <sub>A</sub> = 80°C <sup>(8)</sup>	<b>MR856</b>	1.25 @ 3.0 A	200	100	150	267-03
400	6	T <sub>A</sub> = 60°C R <sub>θJA</sub> = 25°C/W	<b>MR754</b>	1.25 @ 100 A	—	400	175	194-04
1000	6	T <sub>A</sub> = 60°C R <sub>θJA</sub> = 25°C/W	<b>MR760</b>	1.25 @ 100 A	—	400	175	194-04
1500	10	T <sub>C</sub> = 125°C	<b>MR10150E</b>	1.8 @ 6.5 A	1000	100	125	221B
1200	10	T <sub>C</sub> = 125°C	<b>MR10120E</b>	1.5 @ 6.5 A	1000	100	125	221B
400	25	T <sub>C</sub> = 150°C	<b>MR2504</b>	1.18 @ 78.5 A	—	400	175	193-04
1000	25	T <sub>C</sub> = 150°C	<b>MR2510</b>	1.18 @ 78.5 A	—	400	175	193-04
100	30	T <sub>C</sub> = 125°C	<b>MR4422CTR</b>	1.2 @ 15 A	—	400	150	1-07 Style 8
100	30	T <sub>C</sub> = 125°C	<b>MR4422CT</b>	1.2 @ 15 A	—	400	150	1-07 Style 9
20	35	T <sub>C</sub> = 150°C	<b>MR2535L(11)</b>	1.1 @ 100 A	—	400	175	194-04

(3) Package Size: 0.120" max diameter by 0.260" length.  
 (8) Must be derated for reverse power dissipation. See data sheet.  
 (10) Request data sheet for mounting information.  
 (11) Overvoltage Transient Suppressor: 24–32 volts avalanche voltage.

Devices listed in bold, italic are Motorola preferred devices.

5

# Thyristors and Triggers

---

## In Brief . . .

Motorola's broad line of Thyristors includes. . . .

- A full line of TRIACs and SCRs covering a forward current range from 0.5 to 55 amperes and blocking voltages from 15 to 800 volts. The TRIAC line also includes optically-coupled TRIAC drivers from Motorola's Optoelectronic product line.
- A full line of TRIACs and SCRs covering a forward current range from 0.5 to 55 amperes and blocking voltages from 15 to 800 volts. The TRIAC line also includes optically-coupled TRIAC drivers from Motorola's Optoelectronic product line.
- Two basic package categories — plastic for lowest cost which includes the fully insulated plastic Case 221C (TO-220 Isolated) and metal for hermetically-sealed requirements in high-reliability projects.
- An extensive line of trigger devices that includes SIDACs, PUTs and SBS.

Then there are the special applications devices for Ignition circuits and Crowbar applications. Also included are isolated packaged devices for appliances and surface mount packages for surface mounting in space-saving requirements.

Finally, there is the continued Motorola investment in discrete-product R & D producing new capabilities such as transient SIDACs for use in circuits sensitive to high voltage transients.

	<b>Page</b>
Silicon Controlled Rectifiers . . . . .	5.7-2
TRIACs . . . . .	5.7-7
General Purpose . . . . .	5.7-7
Optically Isolated TRIACs . . . . .	5.7-16
Triac Driver/Triac Combinations . . . . .	5.7-16
Thyristor Triggers . . . . .	5.7-17
SIDACs . . . . .	5.7-17
Programmable Unijunction Transistors — PUT . . . . .	5.7-17
Silicon Bidirectional Switch (SBS) . . . . .	5.7-17

# SCRs

## Silicon Controlled Rectifiers

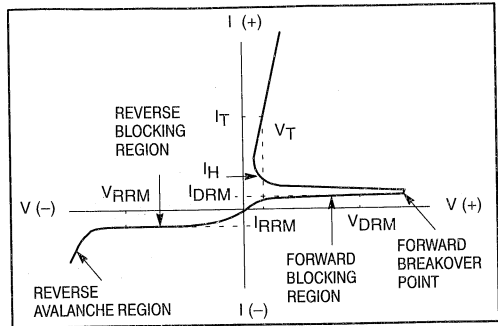
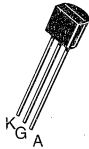



Table 1. SCRs — General Purpose Metal/Plastic Packages  
0.8 to 55 Amperes RMS, 25 to 800 Volts

On-State (RMS) Current				V <sub>DRM</sub> V <sub>RRM</sub> (Volts)
0.8 AMP		1.5 AMPS		
T <sub>C</sub> = 58°C		T <sub>C</sub> = 80°C		
				
Sensitive Gate				V <sub>DRM</sub> V <sub>RRM</sub> (Volts)
Case 29-04 TO-226AA (TO-92) Style 10		Case 318E SOT-223 STYLE 10		
MCR102 2N5060	BRX44/BRY55-30 <sup>(4)</sup>			
MCR103 2N5061	BRX45/BRY55-60 <sup>(4)</sup>		<b>MCR22-2</b>	
<b>MCR100-3</b> <b>2N5062</b>	BRX46/BRY55-100 <sup>(4)</sup>		<b>MCR22-3</b>	
<b>MCR100-4</b> <b>2N5064</b>	BRX47/BRY55-200 <sup>(4)</sup>	<b>MCR08BT1</b>	<b>MCR22-4</b>	
<b>MCR100-6</b>	BRX49/BRY55-400 <sup>(4)</sup>	<b>MCR08DT1</b>	<b>MCR22-6</b>	
	BRY55-500 <sup>(4)</sup>			
<b>MCR100-8</b>	BRY55-600 <sup>(4)</sup>	<b>MCR08MT1</b>	<b>MCR22-8</b>	
Maximum Electrical Characteristics				
10	15 150 <sup>(3)</sup>	10	15 150 <sup>(3)</sup>	I <sub>TSM</sub> (Amps) 60 Hz
0.2				I <sub>GT</sub> (mA)
0.8				V <sub>GT</sub> (V)
-65 to +110	-40 to +125	-40 to +110	-40 to +125	T <sub>J</sub> Operating Range (°C)

(3) Exponential decay 2 μs wide at 5 time constants, f = 12 Hz.



(4) European Part Numbers. Package is Case 29 with Leadform 18. Case style is 3.

Devices listed in bold, italic are Motorola preferred devices.

5

SCRs (continued)

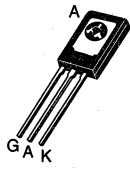
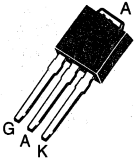
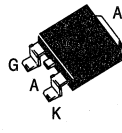
Table 1. SCRs — General Purpose Metal/Plastic Packages (continued)

V <sub>DRM</sub> V <sub>RRM</sub> (Volts)	On-State (RMS) Current				
	4 AMPS			6 AMPS	
	T <sub>C</sub> = 93°C		T <sub>C</sub> = 30°C		
					
	Sensitive Gate		Surface Mount	Sensitive Gate	
Case 77 TO-225AA (TO-126) Style 2		Case 369 Style 5	Case 369A Style 5	Case 77 TO-225AA (TO-126) Style 2	
50	<i>MCR106-2</i> <i>2N6237</i>	<i>C106F</i>			MCR506-2
100	MCR106-3 2N6238	<i>C106A</i>	<i>MCR703A1</i>	<i>MCR703A</i> <sup>(5)</sup>	MCR506-3
200	<i>MCR106-4</i> <i>2N6239</i>	<i>C106B</i>	<i>MCR704A1</i>	<i>MCR704A</i> <sup>(5)</sup>	MCR506-4
400	<i>MCR106-6</i> <i>2N6240</i>	<i>C106D</i>	<i>MCR706A1</i>	<i>MCR706A</i> <sup>(5)</sup>	MCR506-6
600	<i>MCR106-8</i> <i>2N6241</i>	<i>C106M</i>	<i>MCR708A1</i>	<i>MCR708A</i> <sup>(5)</sup>	MCR506-8
800					
Maximum Electrical Characteristics					
I <sub>TSM</sub> (Amps) 60 Hz	25	20	25		40
I <sub>GT</sub> (mA)	0.2		0.075	0.075	0.2
V <sub>GT</sub> (V)	1	0.8	1		
T <sub>J</sub> Operating Range (°C)	-40 to +110				

<sup>(5)</sup>Available in tape and reel — add RL suffix to part number.



5

Devices listed in bold, italic are Motorola preferred devices.

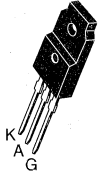
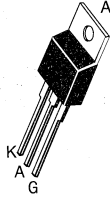

SCRs (continued)

Table 1. SCRs — General Purpose Metal/Plastic Packages (continued)

On-State (RMS) Current					V <sub>DRM</sub> V <sub>RRM</sub> (Volts)
8 AMPS			10 AMPS		
T <sub>C</sub> = 70°C	T <sub>C</sub> = 75°C	T <sub>C</sub> = 83°C	T <sub>C</sub> = 75°C		
			Sensitive Gate		
Isolated 	Case 221A-04 TO-220AB Style 3				
Case 221C Style 2	Case 221A-04 TO-220AB Style 3				
<i>MCR218-2FP</i>	<i>MCR218-2</i>	<i>C122F1</i>	<i>MCR72-2</i>	MCR310-2	50
	<i>MCR218-3</i>	<i>C122A1</i>	<i>MCR72-3</i>	<i>MCR310-3</i>	100
<i>MCR218-4FP</i>	<i>MCR218-4</i>	<i>C122B1</i>	<i>MCR72-4</i>	<i>MCR310-4</i>	200
<i>MCR218-6FP</i>	<i>MCR218-6</i>	<i>C122D1</i>	<i>MCR72-6</i>	<i>MCR310-6</i>	400
MCR218-8FP	<i>MCR218-8</i>	<i>C122M1</i>	<i>MCR72-8</i>	MCR310-8	600
MCR218-10FP	MCR218-10	<i>C122N1</i>	MCR72-10	MCR310-10	800
Maximum Electrical Characteristics					
80		90	100		I <sub>TSM</sub> (Amps) 60 Hz
25			0.2		I <sub>GT</sub> (mA)
1.5					V <sub>GT</sub> (V)
-40 to +125		-40 to +100	-40 to +110		T <sub>J</sub> Operating Range (°C)

 Indicates UL Recognized — File #E69369

Devices listed in bold, italic are Motorola preferred devices.

5

SCRs (continued)

Table 1. SCRs — General Purpose Metal/Plastic Packages (continued)

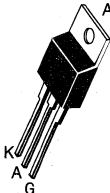
V <sub>DRM</sub> V <sub>RRM</sub> (Volts)	On-State (RMS) Current				
	10 AMPS	12 AMPS		16 AMPS	25 AMPS
	T <sub>C</sub> = 75°C	T <sub>C</sub> = 85°C	T <sub>C</sub> = 90°C		T <sub>C</sub> = 85°C
					
Case 221A-04 TO-220AB Style 3					
50	S2800F	MCR68-2	<b>2N6394</b>	<b>2N6400</b>	<b>2N6504</b>
100	S2800A	MCR68-3	<b>2N6395</b>	<b>2N6401</b>	<b>2N6505</b>
200	S2800B		<b>2N6396</b>	2N6402	<b>2N6506</b>
400	S2800D	MCR68-6	<b>2N6397</b>	<b>2N6403</b>	<b>2N6507</b>
600	S2800M		<b>2N6398</b>	<b>2N6404</b>	<b>2N6508</b>
800	S2800N		<b>2N6399</b>	<b>2N6405</b>	<b>2N6509</b>
Maximum Electrical Characteristics					
I <sub>TSM</sub> (Amps) 60 Hz	100	300(2)	100	160	300
I <sub>GT</sub> (mA)	15	30			40
V <sub>GT</sub> (V)	1.5				
T <sub>J</sub> Operating Range (°C)	-40 to +100	-40 to +125			



5

(2) Peak capacitor discharge current for  $t_w = 1$  ms.  $t_w$  is defined as five time constants of an exponentially decaying current pulse (crowbar applications).

Devices listed in bold, italic are Motorola preferred devices.

# SCRs (continued)

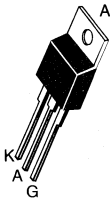
Table 1. SCRs — General Purpose Metal/Plastic Packages (continued)

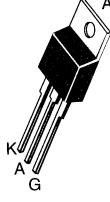
On-State (RMS) Current				V <sub>DRM</sub> V <sub>RRM</sub> (Volts)
25 AMPS		40 AMPS	55 AMPS	
T <sub>C</sub> = 85°C		T <sub>C</sub> = 80°C	T <sub>C</sub> = 70°C	
	 Isolated 			
Case 221A-04 TO-220AB Style 3	Case 221C Style 2	Case 221A-04 TO-220AB Style 3		
MCR69-2	<b>MCR225-2FP</b>		<b>MCR265-2</b>	50
MCR69-3				100
	<b>MCR225-4FP</b>	<b>MCR264-4</b>	<b>MCR265-4</b>	200
MCR69-6	<b>MCR225-6FP</b>	<b>MCR264-6</b>	<b>MCR265-6</b>	400
	<b>MCR225-8FP</b>	<b>MCR264-8</b>	<b>MCR265-8</b>	600
	<b>MCR225-10FP</b>	<b>MCR264-10</b>	<b>MCR265-10</b>	800
Maximum Electrical Characteristics				
750 <sup>(2)</sup>	300	400	550	I <sub>TSM</sub> (Amps) 60 Hz
30	40	50		I <sub>GT</sub> (mA)
1.5				V <sub>GT</sub> (V)
-40 to +125				T <sub>J</sub> Operating Range (°C)

(2) Peak capacitor discharge current for  $t_w = 1$  ms.  $t_w$  is defined as five time constants of an exponentially decaying current pulse (crowbar applications).

 Indicates UL Recognized — File #E69369

Devices listed in bold, italic are Motorola preferred devices.

5

# TRIACs

**Table 2. TRIACs — General Purpose Metal/Plastic Packages**  
0.6 to 40 Amperes, 200 to 800 Volts

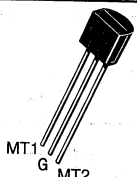
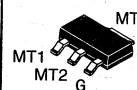
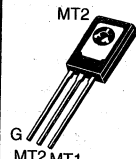
V <sub>DRM</sub> (Volts)	On-State (RMS) Current				
	0.6 AMP			0.8 AMPS	2.5 AMPS
	T <sub>C</sub> = 50°C			T <sub>C</sub> = 80°C	T <sub>C</sub> = 70°C
					
	Sensitive Gate				
Case 29-04 TO-226AA (TO-92) Style 12			Case 318E Style 11 SOT-223	Case 77 TO-225AA (TO-126) Style 5	
200	<i>MAC97-4</i>	<i>MAC97A4</i>	MAC97B4	<i>MAC08BT1</i>	<i>T2322B</i>
400	<i>MAC97-6</i>	<i>MAC97A6</i>	MAC97B6	<i>MAC08DT1</i>	<i>T2322D</i>
600	<i>MAC97-8</i>	<i>MAC97A8</i>	MAC97B8	<i>MAC08MT1</i>	<i>T2322M</i>
Maximum Electrical Characteristics					
I <sub>TSM</sub> (Amps)	8			10	25
I <sub>GT</sub> @ 25°C (mA)					
MT2(+)/G(+)	10	5	3	10	10
MT2(+)/G(-)	10	5	3	10	10
MT2(-)/G(-)	10	5	3	10	10
MT2(-)/G(+)	10	7	5	10	10
V <sub>GT</sub> @ 25°C (V)					
MT2(+)/G(+)	2			0.8	2.2
MT2(+)/G(-)	2			2	2.2
MT2(-)/G(-)	2			2	2.2
MT2(-)/G(+)	2.5			2	2.2
T <sub>J</sub> Operating Range (°C)	-40 to +110				

5

Devices listed in bold, italic are Motorola preferred devices.

# TRIACs (continued)

Table 2. TRIACs (continued)

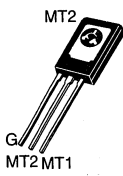
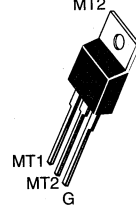
On-State (RMS) Current						
2.5 AMPS		4 AMPS		6 AMPS		
$T_C = 70^\circ\text{C}$		$T_C = 85^\circ\text{C}$		$T_C = 80^\circ\text{C}$		
						
Sensitive Gate					$V_{DRM}$ (Volts)	
Case 77 TO-225AA (TO-126) Style 5				Case 221A-04 TO-220AB Style 4		
<b><i>T2323B</i></b>	<b><i>2N6071</i></b>	<b><i>2N6071A</i></b>	<b><i>2N6071B</i></b>	T2500B		200
<b><i>T2323D</i></b>	<b><i>2N6073</i></b>	<b><i>2N6073A</i></b>	<b><i>2N6073B</i></b>	T2500D		400
<b><i>T2323M</i></b>	<b><i>2N6075</i></b>	<b><i>2N6075A</i></b>	<b><i>2N6075B</i></b>	T2500M		600
				T2500N	800	
Maximum Electrical Characteristics						
25	30			60	$I_{TSM}$ (Amps)	
25	30	5	3	25	$I_{GT}$ @ 25°C (mA) MT2(+) $G(+)$ MT2(+) $G(-)$ MT2(-) $G(-)$ MT2(-) $G(+)$	
40	—	5	3	60		
25	30	5	3	25		
40	—	10	5	60		
2.2	@ -40°C	@ -40°C		2.5	$V_{GT}$ @ 25°C (V) MT2(+) $G(+)$ MT2(+) $G(-)$ MT2(-) $G(-)$ MT2(-) $G(+)$	
2.2	2.5	2.5		2.5		
2.2	—	2.5		2.5		
2.2	2.5	2.5		2.5		
2.2	—	2.5		2.5		
-40 to +110		-40 to +100			$T_J$ Operating Range (°C)	

5

Devices listed in bold, italic are Motorola preferred devices.

# TRIACs (continued)

Table 2. TRIACs (continued)

V <sub>DRM</sub> (Volts)	On-State (RMS) Current				
	6 AMPS			8 AMPS	
	T <sub>C</sub> = 80°C				
	Isolated				
	Case 221A-04 TO-220AB Style 4	Case 221C Style 3	Case 221A-06 TO-220AB Style 4		
200	T2801B	T2500BFP	SC141B	SC143B	<b>MAC218-4</b> <b>MAC218A4</b>
400	T2801D	<b>T2500DFP</b>	SC141D	SC143D	<b>MAC218-6</b> <b>MAC218A6</b>
600	T2801M	T2500MFP	SC141M	SC143M	<b>MAC218-8</b> <b>MAC218A8</b>
800		T2500NFP	SC141N		MAC218-10 <b>MAC218A10</b>
Maximum Electrical Characteristics					
I <sub>TSM</sub> (Amps)	80	100	80	100	
I <sub>GT</sub> @ 25°C (mA)					
MT2(+) G(+)	80	25	50	50	50
MT2(+) G(-)	—	60	50	50	50
MT2(-) G(-)	80	25	50	50	50
MT2(-) G(+)	—	60	—	—	75(1)
V <sub>GT</sub> @ 25°C (V)					
MT2(+) G(+)	2.5	—	2.5	2	2
MT2(+) G(-)	2.5	—	2.5	2	2
MT2(-) G(-)	2.5	—	2.5	2	2
MT2(-) G(+)	2.5	—	—	—	2.5(1)
T <sub>J</sub> Operating Range (°C)	-40 to +100	—	-40 to +110	-40 to +125	—

(1) Applied to A-version only. Non A-version is unspecified.



Indicates UL Recognized — File #E69369

5

Devices listed in bold, italic are Motorola preferred devices.

# TRIACs (continued)

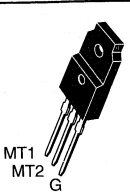
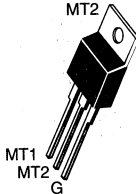
Table 2. TRIACs (continued)

On-State (RMS) Current							V <sub>DRM</sub> (Volts)	
8 AMPS								
T <sub>C</sub> = 80°C								
 								
Isolated 		High Noise Immunity					Case 221C Style 3	Case 221A-04 TO-220AB Style 4
<b>MAC218-4FP</b> <b>MAC218A4FP</b>	MAC219-4				2N6342 <b>2N6346</b>	T2800B		
<b>MAC218-6FP</b> <b>MAC218A6FP</b>	MAC219-6			<b>MAC8D</b>	<b>2N6343</b> <b>2N6347</b>	T2800D	400	
		<b>MAC137-500</b>	<b>MAC137G-500</b>				500	
<b>MAC218-8FP</b> <b>MAC218A8FP</b>	MAC219-8	<b>MAC137-600</b>	<b>MAC137G-600</b>	<b>MAC8M</b>	<b>2N6344</b> <b>2N6348</b>	T2800M	600	
<b>MAC218-10FP</b> <b>MAC218A10FP</b>	MAC219-10	<b>MAC137-800</b>	<b>MAC137G-800</b>	<b>MAC8N</b>	2N6345 <b>2N6349</b>		800	
Maximum Electrical Characteristics								
100		60		80	100		I <sub>TSM</sub> (Amps)	
50	100	35	50	35	50	25	I <sub>GT</sub> @ 25°C (mA)	
50	100	35	50	35	75(6)	60	MT2(+) <i>G</i> (+)	
50	100	35	50	35	50	25	MT2(+) <i>G</i> (-)	
75(1)	—	70	100	—	75(6)	60	MT2(-) <i>G</i> (-)	
							MT2(-) <i>G</i> (+)	
2	2	1.5		1.5	2	2.5	V <sub>GT</sub> @ 25°C (V)	
2	2	1.5		1.5	2.5(6)	2.5	MT2(+) <i>G</i> (+)	
2	2	1.5		1.5	2.5	2.5	MT2(+) <i>G</i> (-)	
2.5(1)	—	1.5		—	2.5(6)	2.5	MT2(-) <i>G</i> (-)	
							MT2(-) <i>G</i> (+)	
-40 to +125						-40 to +100	T <sub>J</sub> Operating Range (°C)	

(1) Applied to A-version only. Non A-version is unspecified.

(6) Denotes 2N6346-49 Series only.



 Indicates UL Recognized — File #E69369

Devices listed in bold, italic are Motorola preferred devices.

5

# TRIACs (continued)

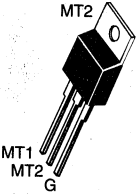
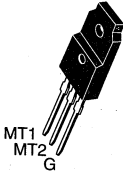
Table 2. TRIACs (continued)

V <sub>DRM</sub> (Volts)	On-State (RMS) Current				
	8 AMPS				
	T <sub>C</sub> = 80°C				
					
				Isolated 	
Sensitive Gate					
Case 221A-04 TO-220AB Style 4			Case 221C Style 3		
200	T2802B	<b>MAC228-4</b> <b>MAC228A4</b>	<b>MAC229-4</b> <b>MAC229A4</b>	<b>MAC228-4FP</b> <b>MAC228A4FP</b>	<b>MAC229-4FP</b> <b>MAC229A4FP</b>
400	T2802D	<b>MAC228-6</b> <b>MAC228A6</b>	<b>MAC229-6</b> <b>MAC229A6</b>	<b>MAC228-6FP</b> <b>MAC228A6FP</b>	<b>MAC229-6FP</b> <b>MAC229A6FP</b>
600		<b>MAC228-8</b> <b>MAC228A8</b>	<b>MAC229-8</b> <b>MAC229A8</b>	<b>MAC228-8FP</b> <b>MAC228A8FP</b>	<b>MAC229-8FP</b> <b>MAC229A8FP</b>
800	T2802M	<b>MAC228-10</b> <b>MAC228A10</b>	<b>MAC229-10</b> <b>MAC229A10</b>	<b>MAC228-10FP</b> <b>MAC228A10FP</b>	<b>MAC229-10FP</b> <b>MAC229A10FP</b>
Maximum Electrical Characteristics					
I <sub>TSM</sub> (Amps)	100	80			
I <sub>GT</sub> @ 25°C (mA)					
MT2(+) <b>G(+)</b>	50	5	10	5	10
MT2(+) <b>G(-)</b>	—	5	10	5	10
MT2(-) <b>G(-)</b>	50	5	10	5	10
MT2(-) <b>G(+)</b>	—	10 <sup>(1)</sup>	20 <sup>(1)</sup>	10 <sup>(1)</sup>	20 <sup>(1)</sup>
V <sub>GT</sub> @ 25°C (V)					
MT2(+) <b>G(+)</b>	2.5	2			
MT2(+) <b>G(-)</b>	—	2			
MT2(-) <b>G(-)</b>	2.5	2			
MT2(-) <b>G(+)</b>	—	2.5 <sup>(1)</sup>			
T <sub>J</sub> Operating Range (°C)	-40 to +100	-40 to +110			

(1) Applied to A-version only. Non A-version is unspecified.

 Indicates UL Recognized — File #E69369



5

Devices listed in bold, italic are Motorola preferred devices.

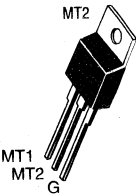
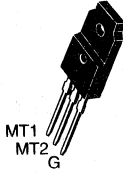
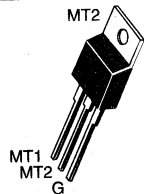

# TRIACs (continued)

Table 2. TRIACs (continued)

On-State (RMS) Current						
8 AMPS		10 AMPS				
$T_C = 80^\circ\text{C}$	$T_C = 70^\circ\text{C}$	$T_C = 80^\circ\text{C}$	$T_C = 70^\circ\text{C}$	$T_C = 75^\circ\text{C}$		
						
High Noise Immunity			Isolated 	Sensitive Gate		
Case 221A-04 TO-220AB Style 4		Case 221C Style 3		Case 221A-04 TO-220AB Style 4	$V_{DRM}$ (Volts)	
<b>MAC9D</b>	<b>MAC210-4</b> <b>MAC210A4</b>	SC146B	<b>MAC210-4FP</b> <b>MAC210A4FP</b>	<b>MAC310-4</b> <b>MAC310A4</b>	200	
	<b>MAC210-6</b> <b>MAC210A6</b>	SC146D	<b>MAC210-6FP</b> <b>MAC210A6FP</b>	<b>MAC310-6</b> <b>MAC310A6</b>	400	
<b>MAC9M</b>	<b>MAC210-8</b> <b>MAC210A8</b>	SC146M	<b>MAC210-8FP</b> <b>MAC210A8FP</b>	<b>MAC310-8</b> <b>MAC310A8</b>	600	
<b>MAC9N</b>	<b>MAC210-10</b> <b>MAC210A10</b>	SC146N	<b>MAC210-10FP</b> <b>MAC210A10FP</b>	<b>MAC310-10</b> <b>MAC310A10</b>	800	
Maximum Electrical Characteristics						
80	100	120	100		$I_{TSM}$ (Amps)	
					$I_{GT}$ @ 25°C (mA)	
50	50	50	50	5	MT2(+) <b>G(+)</b>	
50	50	50	50	5	MT2(+) <b>G(-)</b>	
50	50	50	50	5	MT2(-) <b>G(-)</b>	
—	75(1)	—	75(1)	10(1)	MT2(-) <b>G(+)</b>	
					$V_{GT}$ @ 25°C (V)	
1.5	2	2.5	2	2	MT2(+) <b>G(+)</b>	
1.5	2	2.5	2	2	MT2(+) <b>G(-)</b>	
1.5	2	2.5	2	2	MT2(-) <b>G(-)</b>	
—	2.5(1)	—	2.5(1)	2.5(1)	MT2(-) <b>G(+)</b>	
					$T_J$ Operating Range (°C)	
					-40 to +125	

(1) Applied to A-version only. Non A-version is unspecified.



 Indicates UL Recognized — File #E69369

Devices listed in bold, italic are Motorola preferred devices.

5

# TRIACs (continued)

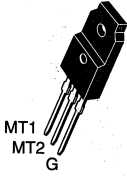
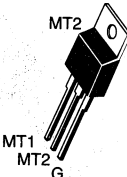
Table 2. TRIACs (continued)

V <sub>DRM</sub> (Volts)	On-State (RMS) Current						
	12 AMPS						
	T <sub>C</sub> = 85°C			T <sub>C</sub> = 80°C			
							
	Isolated 	High Noise Immunity					
	Case 221C Style 3				Case 221A-04 TO-220AB Style 4		
200	<i>MAC212-4FP</i> <i>MAC212A4FP</i>	<i>MAC212-4</i> <i>MAC212A4</i>	<i>MAC213-4</i>	SC149B	2N6342A	2N6346A	
400	<i>MAC212-6FP</i> <i>MAC212A6FP</i>	<i>MAC212-6</i> <i>MAC212A6</i>	<i>MAC213-6</i>	SC149D	<b>2N6343A</b>	2N6347A	
600	<i>MAC212-8FP</i> <i>MAC212A8FP</i>	<i>MAC212-8</i> <i>MAC212A8</i>	<i>MAC213-8</i>	SC149M	<b>2N6344A</b>	2N6348A	
800	<i>MAC212-10FP</i> <i>MAC212A10FP</i>	<i>MAC212-10</i> <i>MAC212A10</i>	<i>MAC213-10</i>		2N6345A	2N6349A	
Maximum Electrical Characteristics							
I <sub>TSM</sub> (Amps)	100			120			
I <sub>GT</sub> @ 25°C (mA)							
MT2(+) <i>G</i> (+)	50	50	100	50	50	50	
MT2(+) <i>G</i> (-)	50	50	100	50	—	75	
MT2(-) <i>G</i> (-)	50	50	100	50	50	50	
MT2(-) <i>G</i> (+)	75(1)	75(1)	—	—	—	75	
V <sub>GT</sub> @ 25°C (V)							
MT2(+) <i>G</i> (+)	2	2	2	2.5	2	2	
MT2(+) <i>G</i> (-)	2	2	2	2.5	—	2.5	
MT2(-) <i>G</i> (-)	2	2	2	2.5	2	2	
MT2(-) <i>G</i> (+)	2.5(1)	2.5(1)	—	—	—	2.5	
T <sub>J</sub> Operating Range (°C)	-40 to +125						



(1) Applied to A-version only. Non A-version is unspecified.

5

Devices listed in bold, italic are Motorola preferred devices.

# TRIACs (continued)

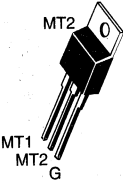
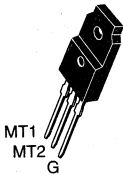
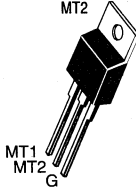
Table 2. TRIACs (continued)

V <sub>DRM</sub> (Volts)	On-State (RMS) Current						
	15 AMPS		16 AMPS	15 AMPS	20 AMPS		
	T <sub>C</sub> = 80°C	T <sub>C</sub> = 90°C	T <sub>C</sub> = 80°C	T <sub>C</sub> = 90°C	T <sub>C</sub> = 75°C		
							
High Noise Immunity			Isolated 				
Case 221A-04 TO-220AB Style 4			Case 221C Style 3		Case 221A-04 TO-220AB Style 4		
200		<i>MAC15-4</i> <i>MAC15A4</i>	<i>MAC16-4</i>		<i>MAC15-4FP</i> <i>MAC15A4FP</i>	<i>MAC320-4FP</i> <i>MAC320A4FP</i>	<i>MAC320-4</i> <i>MAC320A4</i>
400	<i>MAC15D</i>	<i>MAC15-6</i> <i>MAC15A6</i>	<i>MAC16-6</i>	<i>MAC16D</i>	<i>MAC15-6FP</i> <i>MAC15A6FP</i>	<i>MAC320-6FP</i> <i>MAC320A6FP</i>	<i>MAC320-6</i> <i>MAC320A6</i>
600	<i>MAC15M</i>	<i>MAC15-8</i> <i>MAC15A8</i>	<i>MAC16-8</i>	<i>MAC16M</i>	<i>MAC15-8FP</i> <i>MAC15A8FP</i>	<i>MAC320-8FP</i> <i>MAC320A8FP</i>	<i>MAC320-8</i> <i>MAC320A8</i>
800	<i>MAC15N</i>	<i>MAC15-10</i> <i>MAC15A10</i>	<i>MAC16-10</i>	<i>MAC16N</i>	<i>MAC15-10FP</i> <i>MAC15A10FP</i>	<i>MAC320-10FP</i> <i>MAC320A10FP</i>	<i>MAC320-10</i> <i>MAC320A10</i>
Maximum Electrical Characteristics							
I <sub>TSM</sub> (Amps)	150						
I <sub>GT</sub> @ 25°C (mA)							
MT2(+) <i>G</i> (+)	35	50	100	50		50	
MT2(+) <i>G</i> (-)	35	50	100	50		50	
MT2(-) <i>G</i> (-)	35	50	100	50		50	
MT2(-) <i>G</i> (+)	—	75 <sup>(1)</sup>	—	—		75 <sup>(1)</sup>	
V <sub>GT</sub> @ 25°C (V)							
MT2(+) <i>G</i> (+)	2	2	2	1.5		2	
MT2(+) <i>G</i> (-)	2	2	2	1.5		2	
MT2(-) <i>G</i> (-)	2	2	2	1.5		2	
MT2(-) <i>G</i> (+)	—	2.5 <sup>(1)</sup>	—	—		2.5 <sup>(1)</sup>	
T <sub>J</sub> Operating Range (°C)	-40 to +125						

(1) Applied to A-version only. Non A-version is unspecified.



 Indicates UL Recognized — File #E69369

Devices listed in bold, italic are Motorola preferred devices.

5

# TRIACs (continued)

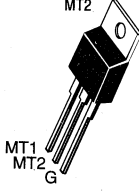
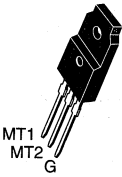
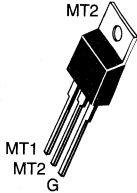
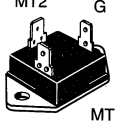
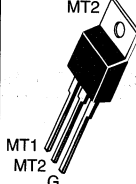
Table 2. TRIACs (continued)

V <sub>DRM</sub> (Volts)	On-State (RMS) Current					
	25 AMPS			35 AMPS	40 AMPS	
	T <sub>C</sub> = 75°C	T <sub>C</sub> = 80°C		T <sub>C</sub> = 85°C	T <sub>C</sub> = 58°C	T <sub>C</sub> = 75°C
						
High Noise Immunity	Isolated 		Isolated 			
Case 221A-04 TO-220AB Style 4	Case 221C Style 3	Case 221A-04 TO-220AB Style 4	Case 383 Style 1	Case 221A-04 TO-220AB Style 4		
200	<b>MAC321-4</b>	<b>MAC223-4FP</b> <b>MAC223A4FP</b>	<b>MAC223-4</b> <b>MAC223A4</b>	MAC625-4	MAC635-4	<b>MAC224-4</b> <b>MAC224A4</b>
400	<b>MAC321-6</b>	<b>MAC223-6FP</b> <b>MAC223A6FP</b>	<b>MAC223-6</b> <b>MAC223A6</b>	MAC625-6	MAC635-6	<b>MAC224-6</b> <b>MAC224A6</b>
600	<b>MAC321-8</b>	<b>MAC223-8FP</b> <b>MAC223A8FP</b>	<b>MAC223-8</b> <b>MAC223A8</b>	MAC625-8	MAC635-8	<b>MAC224-8</b> <b>MAC224A8</b>
800	MAC321-10	<b>MAC223-10FP</b> <b>MAC223A10FP</b>	<b>MAC223-10</b> <b>MAC223A10</b>			MAC224-10 <b>MAC224A10</b>
Maximum Electrical Characteristics						
I <sub>TSM</sub> (Amps)	150	250	250		330	350
I <sub>GT</sub> @ 25°C (mA)						
MT2(+) <b>G(+)</b>	100	50	50	50	50	50
MT2(+) <b>G(-)</b>	100	50	50	50	50	50
MT2(-) <b>G(-)</b>	100	50	50	50	50	50
MT2(-) <b>G(+)</b>	—	75(1)	75(1)	—	—	75(1)
V <sub>GT</sub> @ 25°C (V)						
MT2(+) <b>G(+)</b>	2	2	2	3	3	2
MT2(+) <b>G(-)</b>	2	2	2	3	3	2
MT2(-) <b>G(-)</b>	2	2	2	3	3	2
MT2(-) <b>G(+)</b>	—	2.5(1)	2.5(1)	—	—	2.5(1)
T <sub>J</sub> Operating Range (°C)	-40 to +125					

(1) Applied to A-version only. Non A-version is unspecified.

 Indicates UL Recognized — File #E69369

5

Devices listed in bold, italic are Motorola preferred devices.

# TRIACs (continued)

## Optically Isolated TRIACs

### Triac Driver/Triac Combinations



This series of Triac Drivers consists of infrared LEDs optically coupled to photodetectors with Triac output. 7500 volt isolation between input and output allows safe, economical triggering of higher power triacs from logic

sources with output as low as 3 volts, 10 mA. Associated voltage-compatible triacs provide matched pairs for a variety of voltage/current requirements.

**Table 3. Triac Drivers**

CASE 730A 		
Peak Blocking Voltage Volts	LED Trigger Current $I_{FT}$ mA, Max	Device
250	30	MOC3009
	15	MOC3010
	10	MOC3011
400	30	MOC3020
	15	MOC3021

**For Zero Crossover Firing**

250	30	MOC3030 
	15	MOC3031 
400	30	MOC3040
	15	MOC3031
600	30	MOC3060
	15	MOC3061

 Indicates UL Recognized — File #E54915

**Table 4. Triacs**

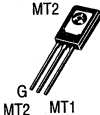
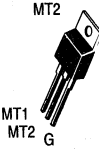
CASE 77 TO-225AA (TO-126) 		CASE 221A-04 TO-220AB 		
Output Current IRMS A, Max	Peak Blocking Voltage Volts			Case
	250	400	600	
4	MAC3010-4	MAC3020-4	—	77
8	-8	-8	—	221A
15	-15	-15	—	221A
25	-25	-25	—	221A
For Zero Crossover Firing				
4	MAC3030-4	MAC3040-4	MAC3060-4	77
8	-8	-8	-8	221A
15	-15	-15	-15	221A
25	-25	-25	-25	221A

**5**

# Thyristor Triggers

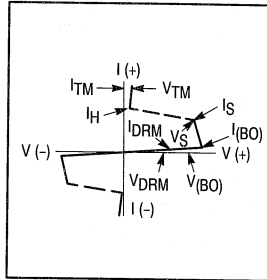

**Table 5. SIDACs**

High voltage trigger devices similar in operation to a Triac. Upon reaching the breakover voltage in either direction, the device switches to a low-voltage on-state.

Device Type	ITSM Amps	VBO Volts	
		Min	Max

**Case 267-03/1**

<i>MKP3V110</i>	20	100	120
<i>MKP3V120</i>	20	110	130
<i>MKP3V130</i>	20	120	140
<i>MKP3V240</i>	20	220	250
<i>MKP3V260</i>	20	240	270
<i>MKP3V270</i>	20	250	280

**Case 59-04/1**

<i>MKP1V120</i>	4	110	130
<i>MKP1V130</i>	4	120	140
<i>MKP1V140</i>	4	130	150
<i>MKP1V240</i>	4	220	250
<i>MKP1V260</i>	4	240	270
<i>MKP1V270</i>	4	250	280

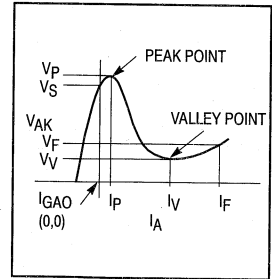

**Table 6. Programmable Unijunction Transistor — PUT**

Similar to UJTs, except that  $I_V$ ,  $I_P$  and intrinsic standoff voltage are programmable (adjustable) by means of external voltage divider. This stabilizes circuit performance for variations in device parameters. General operating frequency range is from 0.01 Hz to 10 kHz, making them suitable for long-duration timer circuits.

Device Type	$I_P$		$I_{GAO}$ @ 40 V nA Max	$I_V$	
	$R_G = 10\text{ k}\Omega$	$R_G = 1\text{ M}\Omega$		$R_G = 10\text{ k}\Omega$	$R_G = 1\text{ M}\Omega$
	$\mu\text{A Max}$			$\mu\text{A Min}$	$\mu\text{A Max}$

**Plastic TO-92 (Case 29-04/16)**

<i>2N6027</i>	5	2	10	70	50
<i>2N6028</i>	1	0.15	10	25	25

5

**Table 7. Silicon Bidirectional Switch (SBS)**

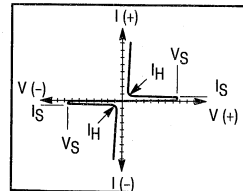

This versatile trigger device exhibits highly symmetrical bidirectional switching characteristics which can be modified by means of a gate lead. Requires a gate trigger current of only 250  $\mu\text{A}$ dc for triggering.

Device Type	Vs Volts		$I_S$ $\mu\text{A Max}$	$I_H$ mA Max
	Min	Max		

**Plastic TO-92/TO-226AA (Case 29-04/12)**

MBS4991	6	10	500	1.5
MBS4992	7.5	9	120	0.5
MBS4993	7.5	9	250	0.75

Devices listed in bold, italic are Motorola preferred devices.

**5**

# Optoelectronic Devices

## In Brief . . .

Motorola's families of optoelectronic components encompass red and infrared GaAs emitters and silicon detectors that are well matched for a variety of applications.

### Optoisolators

Motorola's "Global" 6-Pin Dual In-line Package (DIP) devices use infrared emitting diodes that are optically coupled to a wide selection of output (Transistor, Darlington, Triac, and Schmitt trigger) silicon detectors. These devices are guaranteed to provide at least 7500 volts of isolation between the input and output and are 100% VISO tested. The entire line of Motorola 6-pin DIP packages are recognized by all major safety regulatory agencies including UL and VDE. This extensive line of regulatory approvals attest to their suitability for use under the most stringent conditions. Motorola also offers a line of SOIC-8 small outline, surface mount devices that are UL approved and ideally suited for high density applications.

### POWER OPTO™ Isolators

The MOC2A40 and MOC2A60 series are the first members of the POWER OPTO™ Isolator family from Motorola. The MOC2A40/60 are 2 Amp @ 40°C/400 or 600 Vac(pk)/Zero-Crossing/Optically Coupled Triacs. These isolated AC output devices are ruggedized to survive the harsh operating environments inherent in Industrial Controller applications. Additionally, their thermally optimized SIP package profile allows for high density stacking on .200" centers and can handle 2 Amps @ 40°C (Free-Air Rating) without the need for heatsinks, thermal grease, etc.

### Emitters and Detectors

Motorola emitters (LEDs) are manufactured to operate at wavelengths of 660, 850 or 940 nanometers (nm).

The 940 nm emitters are least expensive. They are well suited for applications where close proximity to the detector tolerates a moderate mismatch in spectral response in exchange for lower cost.

The 850 nm emitters have peak emission which almost exactly matches that of silicon detectors. These emitters are widely used where efficiency and high speeds are of primary importance.

The 660 nm are visible and well matched to the characteristics of low-cost plastic fiber and find wide use in fiber optics communications.

	Page
Optoisolators .....	5.8-2
Safety Standard Approvals for 6-Pin	
Optoisolators .....	5.8-2
Regulatory Approval Certification Index .....	5.8-2
VDE Approved Optoisolators .....	5.8-3
6-Pin Dual In-line Package .....	5.8-5
6-Pin Surface Mount .....	5.8-9
Small Outline — Surface Mount .....	5.8-12
POWER OPTO Isolators .....	5.8-13
Emitters/Detectors .....	5.8-14
Optointerrupters .....	5.8-15
Fiber Optic Components .....	5.8-15

5

Coupled with a line of silicon photodetectors with outputs tailored for specific applications (diodes, transistors, Darlington's, triacs and Schmitt triggers), Motorola's product line offers the engineer a choice of components that can result in optimum system design.

### Fiber Optics

Low cost components offer 10 MHz bandwidth for short distance communications.

### Optointerrupters









Infrared LEDs facing photodetectors in a wide range of slotted packages permit custom design of systems to virtually any physical requirement. A wide selection of outputs (transistor, Darlington, logic, etc.) offers an excellent match for a variety of applications.



# Safety Regulatory Approvals for Motorola's "Global" Optoisolators

Motorola's entire line of 6-pin optoisolators are approved by all major safety regulatory agencies.

## Safety Standard Approvals for 6-Pin Optoisolators

								
	VDE	UL	CSA	SETI	SEMKO	DEMKO	NEMKO	BABT
MOCXXXX	* (1)	*	*	*	*	*	*	*
SOCXXXX	* (1)	*	*	*	*	*	*	*
4NXXXXXX	* (1)	*	*	*	*	*	*	*
H1XXXXXX	* (1)	*	*	*	*	*	*	*
MCXXXXXX	* (1)	*	*	*	*	*	*	*
TIXXXXXX	* (1)	*	*	*	*	*	*	*
CNXXXXXX	* (1)	*	*	*	*	*	*	*

\* = Approved

## Regulatory Approval Certification Index

Regulatory Agency	Certificate File Number
VDE0883	41853 (expired 12/31/91)
VDE0884(1)	62054 (replaces VDE0883)
UL (isolation)	E54915
UL (flammability)	E-8436
CSA	LR93592
SETI	41990
SEMKO	9313138
DEMKO	Approved per SEMKO
NEMKO	A99177
BABT	CR/0117

Note: Motorola's 8-pin surface mount optocouplers are approved by UL only and have a guaranteed isolation voltage of 2500 Vac(rms).

All Motorola 6-pin optocouplers are 100% tested for isolation voltage and are guaranteed to 7500 Vac(peak).

UL Flammability Rating = 94VO (File number E-8436) for all optocouplers.

(1) VDE 0884 testing is an option; the suffix letter "V" must be added to the standard part number.

5

## VDE Approved Optoisolators

VDE has approved Motorola's entire portfolio of 6-pin DIP optoisolators against their new components standard VDE 0884 which replaces VDE 0883. The VDE 0884 components standard requires additional electrical testing to a stringent isolation partial discharge test.

The VDE 0883 specification expired 12/31/91. Motorola optoisolators can now be ordered to comply with the VDE 0884 specification.

VDE approval is based on mechanical and electrical performance of the Motorola package, shown in Figure 3. This 6-Pin DIP package incorporates specially developed materials and assembly processes optimizing thermal and moisture stability while maintaining the high level of LED life and isolation voltage. All Motorola 6-pin DIP optoisolators are made in this package, and have these approvals.

### VDE 0884 Component Standard (replaces VDE 0883)

Electrical ratings in this standard are:

Input-to-Output Voltage, 1 second

$V_{Pr1} = 1.6 V_{IDRM}$ , Partial Discharge < 5 picocoulombs,

$V_{Pr1} = 1280 \text{ V(pk)}$

Maximum operating peak voltage,  $V_{IDRM} = 800 \text{ V(pk)}$

Isolation resistance:  $V_{I-O} = 500 \text{ Vdc}$ ,  $10^{11} \Omega$ ,  $T_A = 100^\circ\text{C}$ .

Note: The isolation partial discharge test  $V_{Pr1}$ , is performed after the completion of the high voltage withstand (hipot) tests.

### VDE 0883 Component Standard (expired 12/31/91)

Electrical ratings in this standard were:

Isolation withstand voltages:

$3750 V_{RMS}$ , 1 min,  $T_A = 100^\circ\text{C}$

$5300 \text{ Vdc}$ , 1 min,  $T_A = 100^\circ\text{C}$

Isolation surge withstand voltage:

10 kV per IEC 65, 50 discharges

Isolation resistance:

$10^{11} \Omega$ , 500 Vdc,  $T_A = 100^\circ\text{C}$

NOTE: VDE 0884/8.87 testing is an option; the suffix letter "V" must be added to the standard part number. (See below.)

Standard thru hole — MOC3063V

.4" wide spaced leadform — MOC3063TV (to satisfy 8 mm spacing requirement)

Standard-profile surface mount — MOC3063SV

Low-profile surface mount — MOC3063FV

Tape and Reel for surface mount — MOC3063S/FR2V

Optoisolators, a block diagram of which is shown in Figure 1, are devices which contain at least one emitter, which is optically coupled to a photo-detector through some sort of an insulating medium. This arrangement permits the passage of information from one circuit, which contains the emitter, to the other circuit containing the detector.

Because this information is passed optically across an insulating gap, the transfer is one-way; that is, the detector cannot affect the input circuit. This is important because the emitter may be driven by a low voltage circuit utilizing an MPU or logic gates, while the output photo-detector may be part of a high voltage DC or even an ac load circuit. The optical isolation prevents interaction or even damage to the input circuit to be caused by the relatively hostile output circuit.

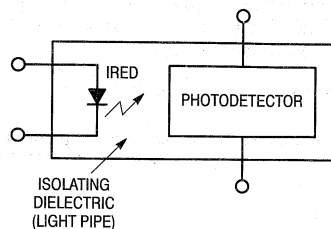

Figure 1. Block Diagram of Optoisolator

Various geometric designs have been used over the years for the internal light cavity between the emitter and detector. Motorola is the industry leader in isolation technology. All 6-pin optoisolators are guaranteed to meet or exceed 7500 Vac (pk) input-to-output isolation. See Figure 2.

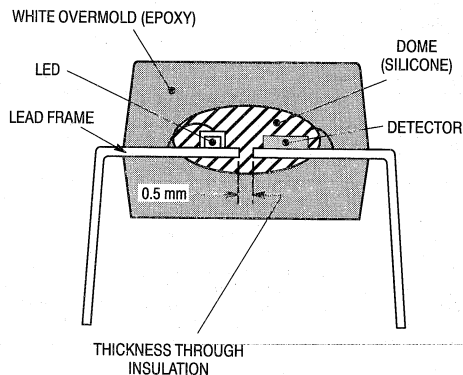

Figure 2. Geometric Design for Optoisolators

## VDE Approved Optoisolators (continued)

### Equipment Standards Compliance

With the approval of the Motorola package to these component standards, combined with its VDE approval ratings, a wide range of Equipment Standards are covered. The table below summarizes these Equipment Standard coverages.

Two levels of electrical interface, or insulation, are used: 1. Reinforced, or safe, insulation; 2. Basic insulation.

**Reinforced Insulation** (sometimes referred to as "safe electrical isolation") is required in an optoisolator interfacing between a hazardous voltage circuit, like an ac line, and a **touchable safe extra low voltage (SELV)** circuit.

**Basic Insulation** is required in an optoisolator which interfaces between a hazardous voltage circuit and a **non-touchable, extra low voltage (ELV)** circuit.

The 6-pin DIP optoisolators are suitable for both levels of electrical interface. The smaller SOIC-8 optoisolators comply with basic Insulation standards only.

Mechanical ratings are shown in the table below.

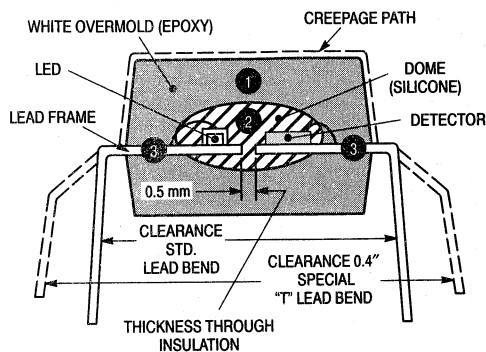

Figure 3. "DOME" Package

### Examples for Safety Applications for Motorola VDE Approved Optoisolators

Standard (2)		Equipment	Requirements for reinforced (double) or safe insulation for equipment with an operating voltage up to 250 Vrms (line voltage to ELV or SELV interfaces)				
VDE (5)	DIN IEC		Creepage	Clearance (1)	Isolation Barrier	Dielectric Strength	Isolation Resistance
			[mm]	[mm]	[mm]	[kV RMS]	[Ω]
0806	950	Office Machines	8.0	8.0	0.5	3.75	7 x 10 <sup>6</sup>
0805	950	Data Processing	8.0	8.0	—	3.75	7 x 10 <sup>6</sup>
0804	—	Telecommunication	8.0	8.0	—	2.5	2 x 10 <sup>6</sup>
0860	65	Electrical Household	6.0	6.0	0.4	3.0 (10)*	4 x 10 <sup>6</sup>
0113	204	Industrial Controls	8.0	8.0	—	2.5	1 x 10 <sup>6</sup>
0160	—	Power Installations with Electronic Equipment	8.0	8.0	—	2.7	1 x 10 <sup>6</sup>
0832	—	Traffic Light Controls	8.0	8.0	—	2.5	4 x 10 <sup>6</sup>
0883	—	Alarm Systems	8.0	8.0	—	2.5	2 x 10 <sup>6</sup>
0831	—	Electrical Signal System for Railroads	8.0	8.0	—	2.0	2 x 10 <sup>6</sup>
0110	—	General Std. for Electrical Equipment	8.0	8.0	—	2.0	—
0883	—	Optoisolator Component Standard (obsolete 12/31/91)	8.5	8.3 (10) (1)	0.5	3.75 (10)*	10 x 10 <sup>11</sup>
0884(4)	—	Optoisolator Component Standard (replaces VDE0883)	> 7.5	> 7.5	0.5	—	10 x 10 <sup>12</sup>
VDE Rating for Motorola 6-pin DIP Optoisolators							

All Motorola 6-pin DIP Optoisolators meet or exceed the requirements of above listed VDE and DIN IEC Standards.

\* Impulse discharge withstand voltage.

(1) To satisfy 8.0 mm creepage path on a PC board Motorola offers a special lead bend of 0.4 inch on all 6-pin dual in-line optoisolators. Order by attaching "T" to the end of the Motorola part number.

(2) VDE standards (translated into English language) and IEC standards can be ordered from the American National Standard Institute ANSI, 1430 Broadway, N.Y., N. Y. 10018, Sales Department, 212-642-4900.

(3) Creepage path distances are measured from lead to lead across the top, bottom and ends of the package body.

(4) VDE 0884 testing is an option; the suffix letter "V" must be added to the standard number.

(5) For more information regarding the use of VDE approved devices, refer to "VDE Circuit Board Layout Design Rules" in the Applications Information section.

5

## 6-Pin Dual In-line Package

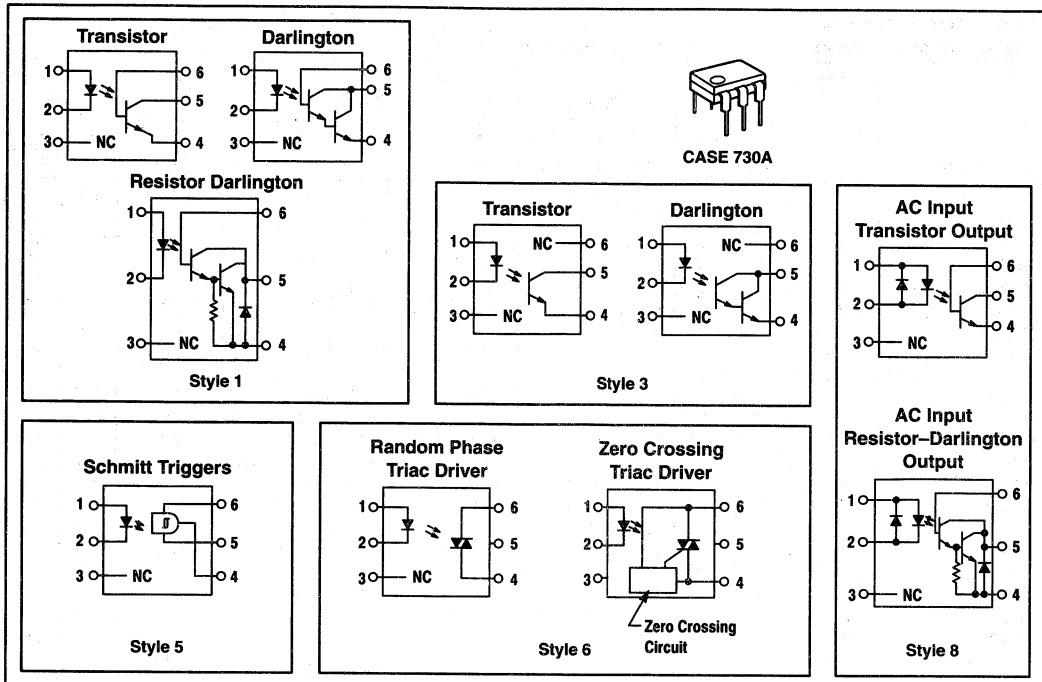

An optoisolator consists of a gallium arsenide infrared emitting diode, IRED, optically coupled to a monolithic silicon photodetector in a wide array of standard devices and encourages the use of special designs and selections for special applications. All Motorola optoisolators have  $V_{ISO}$  rating of 7500 Vac(pk), exceeding all other industry standard ratings.

Motorola offers global regulatory approvals, including UL, Ausetel, NEMKO, BAPT, SETI, SEMKO, DEMKO and CSA. VDE(1) approved per standard 0884/8.87, with additional approvals to DIN IEC950 and IEC380/VDE 0806, IEC435/VDE 0805, IEC65/VDE 0860, VDE 110b, also covering all other standards with equal or less stringent requirements, including IEC204/VDE 0113, VDE 0160, VDE 0832, VDE 0833.

(1) VDE 0884/8.87 testing is an option; the suffix "V" must be added to the standard part number (see page 5.8-3).



**CASE 730A**



**F or S**  
**(F) CASE 730F**  
Surface-mountable  
gull-wing low-profile option  
**(S) CASE 730C**  
Surface-mountable  
gull-wing option



**T**  
**(T) CASE 730D**  
Wide-spaced (0.400")  
lead form option

**Optoisolator Lead Form Options**

All Motorola 6-pin, dual in-line optoisolators are available in either a surface-mountable, gull-wing lead form or a wide-spaced 0.400" lead form, which is used to satisfy 8 mm PC board spacing requirements.

- Attach "F" to any Motorola 6-pin, dual in-line part number for low-profile, surface-mountable, gull-wing lead form.
- Attach "S" to any Motorola 6-pin, dual in-line part number for surface-mountable, gull-wing lead form.
- Attach "T" to any Motorola 6-pin, dual in-line part number for wide-spaced 0.400" lead form.

6-Pin Dual In-Line Package (continued)



CASE 730A

Table 1. Transistor Output  
Pinout: 1-Anode, 2-Cathode, 3-N.C., 4-Emitter, 5-Collector, 6-Base (Style 1)

Device	Current Transfer Ratio (CTR)			V <sub>CE(sat)</sub>			t <sub>r</sub> /t <sub>f</sub> or ton*/toff* Typ					V <sub>(BR)CEO</sub> Volts Min	V <sub>F</sub>			
	%	@	I <sub>F</sub> mA	V <sub>CE</sub> Volts	Volts Max	I <sub>F</sub> mA	I <sub>C</sub> mA	@	I <sub>C</sub> mA	V <sub>CC</sub> Volts	R <sub>L</sub> Ω		I <sub>F</sub> mA	Volts Max	@	I <sub>F</sub> mA
	Min							μs								
TIL112	2	10	5	0.5	50	2	2/2	2	10	100	100		20	1.5	10	
TIL111	8	16	0.4	0.4	16	2	5/5	2	10	100	100		30	1.4	16	
4N27	10	10	10	0.5	50	2	1.2/1.3	10	10	100	100		30	1.5	10	
4N28	10	10	10	0.5	50	2	1.2/1.3	10	10	100	100		30	1.5	10	
4N38,A	10	10	10	1	20	4	1.6/2.2	10	10	100	100		80	1.5	10	
H11A4	10	10	10	0.4	10	0.5	1.2/1.3	2	10	100	100		30	1.5	10	
<b>4N25,A</b>	20	10	10	0.5	50	2	1.2/1.3	10	10	100	100		30	1.5	10	
<b>4N26</b>	20	10	10	0.5	50	2	1.2/1.3	10	10	100	100		30	1.5	10	
H11A2	20	10	10	0.4	10	0.5	1.2/1.3	2	10	100	100		30	1.5	10	
H11A3	20	10	10	0.4	10	0.5	1.2/1.3	2	10	100	100		30	1.5	10	
H11A520	20	10	10	0.4	20	2	5*/5*	2	10	100	100		30	1.5	10	
H11AV3	20	10	10	0.4	20	2	5*/4*	2	10	100	100		70	1.5	10	
MCT2	20	10	10	0.4	16	2	1.2/1.3		5	2k	15	30	1.5	20		
MCT2E	20	10	10	0.4	16	2	1.2/1.3	2	10	100	100		30	1.5	20	
TIL116	20	10	10	0.4	15	2.2	5/5	2	10	100	100		30	1.5	60	
H11A5	30	10	10	0.4	10	0.5	1.2/1.3	2	10	100	100		30	1.7	10	
CNX35	40-160	10	0.4	0.4	10	2	3/3*	2	5	100	100		30	1.5	10	
CNX36	80-200	10	0.4	0.4	10	4	8/6*	2	5	100	100		30	1.5	10	
CNX83	40	10	0.4	0.4	10	4	3/3*	2	5	100	100		50	1.5	10	
CNY17-1	40-80	10	5	0.4	10	2.5	1.6/2.3*		5	75	10	70	1.65	60		
MCT271	45-90	10	10	0.4	16	2	4.9*/4.5*	2	5	100	100		30	1.5	20	
MOC8100	50	1	5	0.5	1	0.1	3.8/5.6	2	10	100	100		30	1.4	1	
H11A1	50	10	10	0.4	10	0.5	1.2/1.3	2	10	100	100		30	1.5	10	
H11A550	50	10	10	0.4	20	2	5*/5*	2	10	100	100		30	1.5	10	
H11AV2	50	10	10	0.4	20	2	5*/4*	2	10	100	100		70	1.5	10	
TIL117	50	10	10	0.4	10	0.5	5/5	2	10	100	100		30	1.4	16	
TIL126	50	10	10	0.4	10	1	2/2	2	10	100	100		30	1.4	10	
SL5501	45-250	10	0.4	0.4	20	2	20*/50*		5	1k	16	30	1.3	20		
<b>CNY17-2</b>	63-125	10	5	0.4	10	2.5	1.6/2.3		5	75	10	70	1.65	60		
MCT275	70-210	10	10	0.4	16	2	4.5*/3.5*	2	5	100	100		80	1.5	20	
MCT272	75-150	10	10	0.4	16	2	6*/5.5*	2	5	100	100		30	1.5	20	
<b>4N35</b>	100	10	10	0.3	10	0.5	3.2/4.7	2	10	100	100		30	1.5	10	
4N36	100	10	10	0.3	10	0.5	3.2/4.7	2	10	100	100		30	1.5	10	
4N37	100	10	10	0.3	10	0.5	3.2/4.7	2	10	100	100		30	1.5	10	
H11A5100	100	10	10	0.4	20	2	5*/5*	2	10	100	100		30	1.5	10	
<b>CNY17-3</b>	100-200	10	5	0.4	10	2.5	1.6/2.3		5	75	10	70	1.65	60		
SL5500	50-300	10	0.4	0.4	50	10	20*/50*		5	1k	16	30	1.3	20		
<b>H11AV1</b>	100-300	10	10	0.4	20	2	5*/4*	2	10	100	100		70	1.5	10	
MCT273	125-250	10	10	0.4	16	2	7.6*/6.6*	2	5	100	100		30	1.5	20	
MCT274	225-400	10	10	0.4	16	2	9.1*/7.9*	2	5	100	100		30	1.5	20	

Table 2. Transistor Output with No Base Connection  
Pinout: 1-Anode, 2-Cathode, 3-N.C., 4-Emitter, 5-Collector, 6-Base (Style 3)

<b>MOC8102</b>	73-117	10	10	0.4	5	0.5	3.2/4.7	2	10	100		30	1.5	10
<b>MOC8103</b>	108-173	10	10	0.4	5	0.5	3.2/4.7	2	10	100		30	1.5	10
<b>MOC8104</b>	160-256	10	10	0.4	5	0.5	3.2/4.7	2	10	100		30	1.5	10
<b>MOC8111</b>	20	10	10	0.4	10	0.5	3.2/4.7	2	10	100		30	1.5	10
CNX82	40	10	0.4	0.4	10	4	3/3*	2	5	100		50	1.5	10
<b>MOC8112</b>	50	10	10	0.4	10	0.5	3.2/4.7	2	10	100		30	1.5	10
MOC8113	100	10	10	0.4	10	0.5	3.2/4.7	2	10	100		30	1.5	10

Devices listed in bold, italic are Motorola preferred devices.

## 6-Pin Dual In-Line Package (continued)



CASE 730A

**Table 3. AC Input – Transistor Output**

Pinout: 1-LED 1 Anode/LED 2 Cathode, 2-LED 1 Cathode/LED 2 Anode, 3-N.C., 4-Emitter, 5-Collector, 6-Base (Style 8)

Device	Current Transfer Ratio (CTR)			V <sub>CE(sat)</sub>			t <sub>r</sub> /t <sub>f</sub> or t <sub>on</sub> /t <sub>off</sub> * Typ					V <sub>(BR)CEO</sub> Volts Min	V <sub>F</sub>	
	%	I <sub>F</sub>	V <sub>CE</sub>	Volts	I <sub>F</sub>	I <sub>C</sub>	t <sub>r</sub>	t <sub>f</sub>	t <sub>on</sub>	t <sub>off</sub>	I <sub>F</sub>		I <sub>F</sub>	
	Min	@ mA	Volts	Max	@ mA	mA	μs	@ mA	V <sub>CC</sub> Volts	R <sub>L</sub> Ω	mA		Max	@ mA
<b>H11AA1</b>	20	±10	10	0.4	±10	0.5						30	1.5	±10
H11AA2	10	±10	10	0.4	±10	0.5						30	1.8	±10
H11AA3	50	±10	10	0.4	±10	0.5						30	1.5	±10
<b>H11AA4</b>	100	±10	10	0.4	±10	0.5						30	1.5	±10

**Table 4. Darlington Output**

Pinout: 1-Anode, 2-Cathode, 3-N.C., 4-Emitter, 5-Collector, 6-Base (Style 1)

4N31	50	10	10	1.2	8	2	0.6*/17*	50	10		200	30	1.5	10
4N29,A	100	10	10	1	8	2	0.6*/17*	50	10		200	30	1.5	10
<b>4N30</b>	100	10	10	1	8	2	0.6*/17*	50	10		200	30	1.5	10
H11B255	100	10	5	1	50	50	125*/100*	10	10	100		55	1.5	20
MCA230	100	10	5	1	50	50	10/35		10	100	50	30	1.5	20
MCA255	100	10	5	1	50	50	10/35		10	100	50	55	1.5	20
<b>H11B2</b>	200	1	5	1	1	1	1/2	10	10	100		25	1.5	10
MCA231	200	1	1	1.2	10	50	80	10	10	100		30	1.5	20
TIL113	300	10	1.25	1	50	125	300	125	15	100		30	1.5	10
<b>4N32,A</b>	500	10	10	1	8	2	0.6*/45*	50	10		200	30	1.5	10
4N33	500	10	10	1	8	2	0.6*/45*	50	10		200	30	1.5	10
<b>H11B1</b>	500	1	5	1	1	1	1/2	10	10	100		25	1.5	10
MOC8080	500	10	5	1	1	1	1/2	10	100	100	5	55	1.5	10

**Table 5. Darlington Output with No Base Connection**

Pinout: 1-Anode, 2-Cathode, 3-N.C., 4-Emitter, 5-Collector, 6-N.C. (Style 3)

MOC119	300	10	2	1	10	10	1/2	2.5	10	100		30	1.5	10
TIL119	300	10	2	1	10	10	300	2.5	10	100		30	1.5	10
<b>MOC8030</b>	300	10	1.5				1/2		50	100	10	80	2	10
MOC8020	500	10	5				1/2		50	100	10	50	2	10
<b>MOC8050</b>	500	10	1.5				1/2		50	100	10	80	2	10
MOC8021	1000	10	5				1/2		50	100	10	50	2	10

**Table 6. Resistor Darlington Output**

Pinout: 1-Anode, 2-Cathode, 3-N.C., 4-Emitter, 5-Collector, 6-Base (Style 1)

<b>H11G1</b>	1000	10	1	1	1	1	5*/100*		5	100	10	100	1.5	10
<b>H11G2</b>	1000	10	1	1	1	1	5*/100*		5	100	10	80	1.5	10
H11G3	200	1	5	1.2	50	20	5*/100*		5	100	10	55	1.5	10

Devices listed in bold, italic are Motorola preferred devices.

5

## 6-Pin Dual In-Line Package (continued)



**Table 7. High Voltage Transistor Output**  
Pinout: 1–Anode, 2–Cathode, 3–N.C., 4–Emitter, 5–Collector, 6–Base (Style 1)

CASE 730A

Device	Current Transfer Ratio (CTR)			$V_{CE(sat)}$			$t_r/t_f$ or $t_{on^*}/t_{off^*}$ Typ					$V_F$		
	% Min	@ $I_F$ mA	$V_{CE}$ Volts	Volts Max	@ $I_F$ mA	$I_C$ mA	@ $I_C$ $\mu s$	$I_C$ mA	$V_{CC}$ Volts	$R_L$ $\Omega$	$I_F$ mA	$V_{(BR)CEO}$ Volts Min	Volts Max	@ $I_F$ mA
<b>MOC8204</b>	20	10	10	0.4	10	0.5	5*/5*	2	10	100		400	1.5	10
<b>H11D1</b>	20	10	10	0.4	10	0.5	5*/5*	2	10	100		300	1.5	10
H11D2	20	10	10	0.4	10	0.5	5*/5*	2	10	100		300	1.5	10

**Table 8. Triac Driver Output**  
Pinout: 1–Anode, 2–Cathode, 3–N.C., 4–Main Terminal, 5–Substrate, 6–Main Terminal (Style 6)

Device	Peak Blocking Voltage Min	LED Trigger Current– $I_{FT}$ ( $V_{TM} = 3 V$ ) mA Max	Zero Crossing Inhibit Voltage (at rated $I_{FT}$ ) Volts Max	Operating Voltage Vac	$dv/dt$ $V/\mu s$ Typ
MOC3009	250	30	—	125	10
<b>MOC3010</b>	250	15	—	125	10
MOC3011	250	10	—	125	10
<b>MOC3012</b>	250	5	—	125	10
MOC3020	400	30	—	125/280	10
<b>MOC3021</b>	400	15	—	125/280	10
MOC3022	400	10	—	125/280	10
MOC3023	400	5	—	125/280	10
<b>MOC3031</b>	250	15	20	125	2000
MOC3032	250	10	20	125	2000
MOC3033	250	5	20	125	2000
<b>MOC3041</b>	400	15	20	125/280	2000
MOC3042	400	10	20	125/280	2000
<b>MOC3043</b>	400	5	20	125/280	2000
<b>MOC3051</b>	600	15	—	125/280	2000
<b>MOC3052</b>	600	10	—	125/280	2000
MOC3061	600	15	20	125/280	1500
MOC3062	600	10	20	125/280	1500
<b>MOC3063</b>	600	5	20	125/280	1500
MOC3081	800	15	20	125/280/320	1500
MOC3082	800	10	20	125/280/320	1500
MOC3162	600	10	15	125/280	1000
MOC3163	600	5	15	125/280	1000

**Table 9. Schmitt Trigger Output**  
Pinout: 1–Anode, 2–Cathode, 3–N.C., 4–Output, 5–Ground, 6– $V_{CC}$  (Style 5)

Device	Threshold Current On mA Max	Threshold Current Off mA Min	$I_{F(off)}/I_{F(on)}$		$V_{CC}$		$t_r, t_f$ $\mu s$ Typ
			Min	Max	Min	Max	
<b>H11L1</b>	1.6	0.3	0.5	0.9	3	16	0.1
H11L2	10	0.3	0.5	0.9	3	16	0.1
<b>MOC5007</b>	1.6	0.3	0.5	0.9	3	16	0.1
MOC5008	4	0.3	0.5	0.9	3	16	0.1
MOC5009	10	0.3	0.5	0.9	3	16	0.1

Devices listed in bold, italic are Motorola preferred devices.

# 6-Pin Surface Mount



(S) CASE 730C  
(F) CASE 730F

Table 10. Transistor Output

Pinout: 1-Anode, 2-Cathode, 3-N.C., 4-Emitter, 5-Collector, 6-Base (Style 1)

Device	Current Transfer Ratio (CTR)			V <sub>CE(sat)</sub>			t <sub>r</sub> /t <sub>f</sub> or t <sub>on</sub> */t <sub>off</sub> * Typ				V(BR)CEO Volts Min	V <sub>F</sub>		
	% Min	I <sub>F</sub> mA	V <sub>CE</sub> Volts	Volts Max	I <sub>F</sub> mA	I <sub>C</sub> mA	μs @	I <sub>C</sub> mA	V <sub>CC</sub> Volts	R <sub>L</sub> Ω		I <sub>F</sub> mA	Volts Max	I <sub>F</sub> mA
TIL112S,F	2	10	5	0.5	50	2	2/2	2	10	100		20	1.5	10
TIL111S,F	8	16	0.4	0.4	16	2	5/5	2	10	100		30	1.4	16
4N27S,F	10	10	10	0.5	50	2	1.2/1.3	10	10	100		30	1.5	10
4N28S,F	10	10	10	0.5	50	2	1.2/1.3	10	10	100		30	1.5	10
4N38S,F	10	10	10	1	20	4	1.6/2.2	10	10	100		80	1.5	10
H11A4S,F	10	10	10	0.4	10	0.5	1.2/1.3	2	10	100		30	1.5	10
4N25S,F	20	10	10	0.5	50	2	1.2/1.3	10	10	100		30	1.5	10
<b>4N25AS,F</b>	20	10	10	0.5	50	2	1.2/1.3	10	10	100		30	1.5	10
<b>4N26S,F</b>	20	10	10	0.5	50	2	1.2/1.3	10	10	100		30	1.5	10
H11A2S,F	20	10	10	0.4	10	0.5	1.2/1.3	2	10	100		30	1.5	10
H11A3S,F	20	10	10	0.4	10	0.5	1.2/1.3	2	10	100		30	1.5	10
H11A520S,F	20	10	10	0.4	20	2	5*/5*	2	10	100		30	1.5	10
H11AV3S,F	20	10	10	0.4	20	2	5*/4*	2	10	100		70	1.5	10
MCT2S,F	20	10	10	0.4	16	2	1.2/1.3	5	2k	15	30	1.5	20	
MCT2ES,F	20	10	10	0.4	16	2	1.2/1.3	2	10	100		30	1.5	20
TIL116S,F	20	10	10	0.4	15	2.2	5/5	2	10	100		30	1.5	60
H11A5S,F	30	10	10	0.4	10	0.5	1.2/1.3	2	10	100		30	1.7	10
CNX35S,F	40-160	10	0.4	0.4	10	2	3/3*	2	5	100		30	1.5	10
CNX36S,F	80-200	10	0.4	0.4	10	4	8/6*	2	5	100		30	1.5	10
CNX83S,F	40	10	0.4	0.4	10	4	3/3*	2	5	100		50	1.5	10
CNY17-1S,F	40-80	10	5	0.4	10	2.5	1.6/2.3	5	75	10	70	1.65	60	
MCT271S,F	45-90	10	10	0.4	16	2	4.9*/4.5*	2	5	100		30	1.5	20
MOC8100S,F	50	1	5	0.5	1	0.1	3.8/5.6	2	10	100		30	1.4	1
H11A1S,F	50	10	10	0.4	10	0.5	1.2/1.3	2	10	100		30	1.5	10
H11A550S,F	50	10	10	0.4	20	2	5*/5*	2	10	100		30	1.5	10
H11AV2S,F	50	10	10	0.4	20	2	5*/4*	2	10	100		70	1.5	10
TIL117S,F	50	10	10	0.4	10	0.5	5/5	2	10	100		30	1.4	16
TIL126S,F	50	10	10	0.4	10	1	2/2	2	10	100		30	1.4	10
SL5501S,F	45-250	10	0.4	0.4	20	2	20*/50*	5	1k	16	30	1.3	20	
<b>CNY17-2S,F</b>	63-125	10	5	0.4	10	2.5	1.6/2.3	5	75	10	70	1.65	60	
MCT275S,F	70-210	10	10	0.4	16	2	4.5*/3.5*	2	5	100		80	1.5	20
MCT272S,F	75-150	10	10	0.4	16	2	6*/5.5*	2	5	100		30	1.5	20
<b>4N35S,F</b>	100	10	10	0.3	10	0.5	3.2/4.7	2	10	100		30	1.5	10
4N36S,F	100	10	10	0.3	10	0.5	3.2/4.7	2	10	100		30	1.5	10
4N37S,F	100	10	10	0.3	10	0.5	3.2/4.7	2	10	100		30	1.5	10
H11A5100S,F	100	10	10	0.4	20	2	5*/5*	2	10	100		30	1.5	10
<b>CNY17-3S,F</b>	100-200	10	5	0.4	10	2.5	1.6/2.3	5	75	10	70	1.65	60	
SL5500S,F	50-300	10	0.4	0.4	50	10	20*/50*	5	1k	16	30	1.3	20	
<b>H11AV1S,F</b>	100-300	10	10	0.4	20	2	5*/4*	2	10	100		70	1.5	10
MCT273S,F	125-250	10	10	0.4	16	2	7.6*/6.6*	2	5	100		30	1.5	20
MCT274S,F	225-400	10	10	0.4	16	2	9.1*/7.9*	2	5	100		30	1.5	20

5

Devices listed in bold, italic are Motorola preferred devices.



6-Pin Surface Mount (continued)



Table 11. Transistor Output with No Base Connection

(S) CASE 730C  
(F) CASE 730F

Pinout: 1–Anode, 2–Cathode, 3–N.C., 4–Emitter, 5–Collector, 6–N.C. (Style 3)

Device	Current Transfer Ratio (CTR)			V <sub>CE(sat)</sub>			t <sub>r</sub> /t <sub>f</sub> or t <sub>on</sub> */t <sub>off</sub> * Typ					V <sub>(BR)CEO</sub>	V <sub>F</sub>	
	% Min	@ mA	V <sub>CE</sub> Volts	Volts Max	I <sub>F</sub> mA	I <sub>C</sub> mA	μs @	I <sub>C</sub> mA	V <sub>CC</sub> Volts	R <sub>L</sub> Ω	I <sub>F</sub> mA	Volts Min	Volts Max	I <sub>F</sub> mA
MOC8101S,F	50–80	10	10	0.4	5	0.5	3.2/4.7	2	10	100		30	1.5	10
<i>MOC8102S,F</i>	73–117	10	10	0.4	5	0.5	3.2/4.7	2	10	100		30	1.5	10
<i>MOC8103S,F</i>	108–173	10	10	0.4	5	0.5	3.2/4.7	2	10	100		30	1.5	10
<i>MOC8104S,F</i>	160–256	10	10	0.4	5	0.5	3.2/4.7	2	10	100		30	1.5	10
<i>MOC8111S,F</i>	20	10	10	0.4	10	0.5	3.2/4.7	2	10	100		30	1.5	10
CNX82S,F	40	10	0.4	0.4	10	4	3/3*	2	5	100		50	1.5	10
<i>MOC8112S,F</i>	50	10	10	0.4	10	0.5	3.2/4.7	2	10	100		30	1.5	10
MOC8113S,F	100	10	10	0.4	10	0.5	3.2/4.7	2	10	100		30	1.5	10

Table 12. AC Input – Transistor Output

Pinout: 1–LED 1 Anode/LED 2 Cathode, 2–LED 1 Cathode/LED 2 Anode, 3–N.C., 4–Emitter, 5–Collector, 6–Base (Style 8)

<i>H11AA1S,F</i>	20	±10	10	0.4	±10	0.5						30	1.5	±10
H11AA2S,F	10	±10	10	0.4	±10	0.5						30	1.8	±10
H11AA3S,F	50	±10	10	0.4	±10	0.5						30	1.5	±10
<i>H11AA4S,F</i>	100	±10	10	0.4	±10	0.5						30	1.5	±10

Table 13. Darlington Output

Pinout: 1–Anode, 2–Cathode, 3–N.C., 4–Emitter, 5–Collector, 6–Base (Style 1)

4N31S,F	50	10	10	1.2	8	2	0.6*/17*	50	10		200	30	1.5	10
4N29S,F	100	10	10	1	8	2	0.6*/17*	50	10		200	30	1.5	10
<i>4N30S,F</i>	100	10	10	1	8	2	0.6*/17*	50	10		200	30	1.5	10
H11B255S,F	100	10	5	1	50	50	125*/100*	10	10	100		55	1.5	20
MCA230S,F	100	10	5	1	50	50	10/35	10	100	100	50	30	1.5	20
MCA255S,F	100	10	5	1	50	50	10/35	10	100	100	50	55	1.5	20
<i>H11B2S,F</i>	200	1	5	1	1	1	1/2	10	10	100		25	1.5	10
MCA231S,F	200	1	1	1.2	10	50	80	10	10	100		30	1.5	20
TIL113S,F	300	10	1.25	1	50	125	300	125	15	100		30	1.5	10
<i>4N32S,F</i>	500	10	10	1	8	2	0.6*/45*	50	10		200	30	1.5	10
4N33S,F	500	10	10	1	8	2	0.6*/45*	50	10		200	30	1.5	10
<i>H11B1S,F</i>	500	1	5	1	1	1	1/2	10	10	100		25	1.5	10
MOC8080S,F	500	10	5	1	1	1	1/2	10	100	100	5	55	1.5	10

Table 14. Darlington Output with No Base Connection

Pinout: 1–Anode, 2–Cathode, 3–N.C., 4–Emitter, 5–Collector, 6–N.C. (Style 3)

MOC119S,F	300	10	2	1	10	10	1/2	2.5	10	100		30	1.5	10
TIL119S,F	300	10	2	1	10	10	300	2.5	10	100		30	1.5	10
<i>MOC8030S,F</i>	300	10	1.5				1/2		50	100	10	80	2	10
MOC8020S,F	500	10	5				1/2		50	100	10	50	2	10
<i>MOC8050S,F</i>	500	10	1.5				1/2		50	100	10	80	2	10
MOC8021S,F	1000	10	5				1/2		50	100	10	50	2	10

For Surface Mountable standard leadform, Order "S" suffix devices; e.g., MOC3043S.

For low profile Surface Mountable leadform, Order "F" suffix devices; e.g., MOC5007F.

For 24 mm Tape and Reel, add R2 suffix to the 6-pin optoisolator part number; e.g., H11A1SR2. (See Tape and Reel Specifications Section for more information)

Devices listed in bold, italic are Motorola preferred devices.

## 6-Pin Surface Mount (continued)



**Table 15. Resistor Darlington Output**

Pinout: 1–Anode, 2–Cathode, 3–N.C., 4–Emitter, 5–Collector, 6–Base (Style 1)

(S) CASE 730C  
(F) CASE 730F

Device	Current Transfer Ratio (CTR)			$V_{CE(sat)}$			$t_r/t_f$ or $t_{on}^*/t_{off}^*$ Typ				$V_{(BR)CEO}$ Volts Min	$V_F$		
	% Min	@ mA	$I_F$ mA	Volts Max	@ mA	$I_C$ mA	$\mu s$	@ mA	$V_{CC}$ Volts	$R_L$ $\Omega$		$I_F$ mA	Volts Max	@ mA
<b>H11G1S,F</b>	1000	10	1	1	1	1	5*/100*		5	100	10	100	1.5	10
<b>H11G2S,F</b>	1000	10	1	1	1	1	5*/100*		5	100	10	80	1.5	10
H11G3S,F	200	1	5	1.2	50	20	5*/100*		5	100	10	55	1.5	10

**Table 16. High Voltage Transistor Output**

Pinout: 1–Anode, 2–Cathode, 3–N.C., 4–Emitter, 5–Collector, 6–Base (Style 1)

<b>MOC8204S,F</b>	20	10	10	0.4	10	0.5	5*/5*	2	10	100		400	1.5	10
<b>H11D1S,F</b>	20	10	10	0.4	10	0.5	5*/5*	2	10	100		300	1.5	10
H11D2S,F	20	10	10	0.4	10	0.5	5*/5*	2	10	100		300	1.5	10

**Table 17. Triac Driver Output**

Pinout: 1–Anode, 2–Cathode, 3–N.C., 4–Main Terminal, 5–Substrate, 6–Main Terminal (Style 6)

Device	Peak Blocking Voltage Min	LED Trigger Current– $I_{FT}$ ( $V_{TM} = 3 V$ ) mA Max	Zero Crossing Inhibit Voltage (at rated $I_{FT}$ ) Volts Max	Operating Voltage $V_{ac}$	$dv/dt$ $V/\mu s$ Typ
MOC3009S,F	250	30	—	125	10
<b>MOC3010S,F</b>	250	15	—	125	10
MOC3011S,F	250	10	—	125	10
<b>MOC3012S,F</b>	250	5	—	125	10
MOC3020S,F	400	30	—	125/280	10
<b>MOC3021S,F</b>	400	15	—	125/280	10
MOC3022S,F	400	10	—	125/280	10
<b>MOC3023S,F</b>	400	5	—	125/280	10
<b>MOC3031S,F</b>	250	15	20	125	2000
MOC3032S,F	250	10	20	125	2000
<b>MOC3033S,F</b>	250	5	20	125	2000
<b>MOC3041S,F</b>	400	15	20	125/280	2000
MOC3042S,F	400	10	20	125/280	2000
<b>MOC3043S,F</b>	400	5	20	125/280	2000
<b>MOC3051S,F</b>	600	15	—	125/280	2000
<b>MOC3052S,F</b>	600	10	—	125/280	2000
MOC3061S,F	600	15	20	125/280	1500
MOC3062S,F	600	10	20	125/280	1500
<b>MOC3063S,F</b>	600	5	20	125/280	1500
MOC3081S,F	800	15	20	320/280/125	1500
MOC3082S,F	800	10	20	320/280/125	1500
MOC3083S,F	800	5	20	320/280/125	1500
MOC3162S,F	600	10	15	—	1000
MOC3163S,F	600	5	15	—	1000

For Surface Mountable standard leadform, Order "S" suffix devices; e.g., MOC3043S.

For low profile Surface Mountable leadform, Order "F" suffix devices; e.g., MOC5007F.

For 24 mm Tape and Reel, add R2 suffix to the 6-pin optoisolator part number; e.g., H11A1SR2. (See Tape and Reel Specifications Section for more information)

5

Devices listed in bold, italic are Motorola preferred devices.

## 6-Pin Surface Mount (continued)

**Table 18. Schmitt Trigger Output**

Pinout: 1–Anode, 2–Cathode, 3–N.C., 4–Output, 5–Ground, 6–V<sub>CC</sub> (Style 5)

Device	Threshold Current On mA Max	Threshold Current Off mA Min	I <sub>F(off)</sub> /I <sub>F(on)</sub>		V <sub>CC</sub>		t <sub>p</sub> , t <sub>f</sub> μs Typ
			Min	Max	Min	Max	
<i>H11L1S,F</i>	1.6	0.3	0.5	0.9	3	16	0.1
H11L2S,F	10	0.3	0.5	0.9	3	16	0.1
<i>MOC5007S,F</i>	1.6	0.3	0.5	0.9	3	16	0.1
MOC5008S,F	4	0.3	0.5	0.9	3	16	0.1
MOC5009S,F	10	0.3	0.5	0.9	3	16	0.1

For Surface Mountable standard leadform, Order "S" suffix devices; e.g., MOC3043S.

For low profile Surface Mountable leadform, Order "F" suffix devices; e.g., MOC5007F.

For 24 mm Tape and Reel, add R2 suffix to the 6-pin optoisolator part number; e.g., H11A1SR2. (See Tape and Reel Specifications Section for more information.)

## Small Outline — Surface Mount

**Table 19. Transistor Output**

Pinout: 1–Anode, 2–Cathode, 3–N.C., 4–N.C., 5–Emitter, 6–Collector, 7–Base, 8–N.C. (Style 1)

Device	Marking	% Min	I <sub>F</sub> mA	V <sub>CE</sub> Volts	V <sub>CE(sat)</sub>			t <sub>r</sub> /t <sub>f</sub> Typ				V <sub>(BR)CEO</sub> Volts Min	V <sub>F</sub>	
					Volts Max	I <sub>F</sub> mA	I <sub>C</sub> mA	@ μs	I <sub>C</sub> mA	V <sub>CC</sub> Volts	R <sub>L</sub> Ω		Volts Max	I <sub>F</sub> mA
MOC205R1/R2	205	40–80	10	10	0.4	10	2	1.6	2	10	100	70	1.5	10
<i>MOC206R1/R2</i>	206	63–125	10	10	0.4	10	2	1.6	2	10	100	70	1.5	10
MOC207R1/R2	207	100–200	10	10	0.4	10	2	1.6	2	10	100	70	1.5	10
<i>MOC211R1/R2</i>	211	20	10	10	0.4	10	2	3.2	2	10	100	30	1.5	10
<i>MOC212R1/R2</i>	212	50	10	10	0.4	10	2	3.2	2	10	100	30	1.5	10
<i>MOC213R1/R2</i>	213	100	10	10	0.4	10	2	3.2	2	10	100	30	1.5	10
<i>MOC215R1/R2</i>	215	20	10	5	0.4	1	0.1	3.2	2	10	100	30	1.3	1
<i>MOC216R1/R2</i>	216	50	10	5	0.4	1	0.1	3.2	2	10	100	30	1.3	1
<i>MOC217R1/R2</i>	217	100	10	5	0.4	1	0.1	3.2	2	10	100	30	1.3	1

**Table 20. Darlington Output**

Pinout: 1–Anode, 2–Cathode, 3–N.C., 4–N.C., 5–Emitter, 6–Collector, 7–Base, 8–N.C. (Style 1)

<i>MOC221R1/R2</i>	221	100	1	5	1	1	0.5	2	5	10	100	30	1.3	1
<i>MOC222R1/R2</i>	222	200	1	5	1	1	0.5	2	5	10	100	30	1.3	1
<i>MOC223R1/R2</i>	223	500	1	5	1	1	0.5	2	5	10	100	30	1.3	1

All devices are shipped in tape and reel format. (See Tape and Reel Specifications Section for more information.)

Devices listed in bold, italic are Motorola preferred devices.

# POWER OPTO™ Isolators

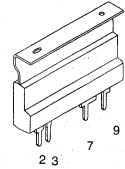

**CASE 417**  
PLASTIC PACKAGE

**Table 1. POWER OPTO Isolator 2 Amp Zero-Cross Triac Output**

**Pinout: (1,4,5,6,8 No Pin), 2 – LED Cathode, 3– LED Anode, 7–Main Terminal, 9–Main Terminal**

Device	Peak Blocking Voltage (Volts) Min	Led Trigger Current $I_T$ ( $V_{TM} = 2 V$ ) mA Max	On State Voltage $V_{TM}$ (Rated $I_{FT}$ $I_{TM} = 2 A$ ) (Volts) Max	Zero Crossing Inhibit Voltage ( $I_F = \text{Rated } I_{FT}$ ) (Volts) Max	Operating Voltage Vac rms (Volts)	dv/dt (static) ( $V_{IN} = 200 V$ ) ( $V/\mu s$ ) Min
<b><i>MOC2A40-5</i></b>	400	5	1.3	10	125	400
<b><i>MOC2A40-10</i></b>	400	10	1.3	10	125	400
<b><i>MOC2A60-5</i></b>	600	5	1.3	10	125/280	400
<b><i>MOC2A60-10</i></b>	600	10	1.3	10	125/280	400

No suffix = Style 2 (Standard Heat Tab), "F" suffix = Style 1 (Flush Mount Heat Tab).

**5**

Devices listed in bold, italic are Motorola preferred devices.

# Emitters/Detectors

## Infrared Emitting Diodes

Motorola's infrared emitting diodes are made by the liquid phase epitaxial process for long life and stability. They provide high power output and quick response at 660 nm, 850 nm or 940 nm with low input drive current.

**Table 1. Infrared Emitting Diodes**

Device	Power Output		Emission Angle Typ	Peak Emission Wavelength nm Typ	Forward Voltage		Case/ Style
	$\mu$ W Typ @	$I_F$ mA			@ $I_F$ Max	$I_F$ mA	
<b>MLED91</b>	2500	50	60°	940	1.8	50	422A/1
<b>MLED96</b>	4000	100	60°	660	2.2	60	422A/4
<b>MLED97</b>	2500	100	60°	850	2	100	422A/4
<b>MLED81</b>	16000	100	60°	940	1.7	100	279B/1
<b>MLED930</b>	650	100	30°	940	1.5	50	209-01/1

## Silicon Photodetectors

A variety of silicon photodetectors are available, varying from simple PIN diodes to a complex, Schmitt trigger. They offer choices of viewing angle and size in either economical plastic cases or rugged, hermetic metal cans. They are spectrally matched for use with Motorola infrared emitting diodes.

**Table 2. PIN Photodiodes – Response Time = 1 ns Typ**

Device	Light Current @ $V_R = 20$ V, $H = 5$ mW/cm <sup>2</sup> $\mu$ A	Dark Current @ $V_R = 20$ V nA (Max)	Case/ Style
MRD500	9	2	209-02/1
MRD510	2	2	210/1
<b>MRD921</b>	4	10	422A/1
<b>MRD821</b>	250	60	381/1

**Table 3. Phototransistors**

Device	Light Current @ $V_{CC} = 20$ , $H = 5$ mW/cm <sup>2</sup> mA (Typ)	$V_{(BR)CEO}$ Volts (Min)	$t_r/t_f$ @ $V_{CC} = 20$ , $I_L = 1000$ $\mu$ A $\mu$ s (Typ)	Case/ Style
MRD310	3.5	50	2/2.5	82-05/1
MRD300	8	50	2/2.5	
MRD3050	0.1 Min	30	2/2.5	
MRD3056	2 Min	30	2/2.5	
<b><math>t_{on}/t_{off}</math> @ <math>V_{CC} = 5</math> V</b>				
<b>MRD901</b>	0.5	30	10/60	422A/2

All case 422 and 422A devices are available in Tape and Reel format. Add RLRE suffix to the part number; e.g. MRD901RLRE. (See Tape and Reel Specifications Section for more information)

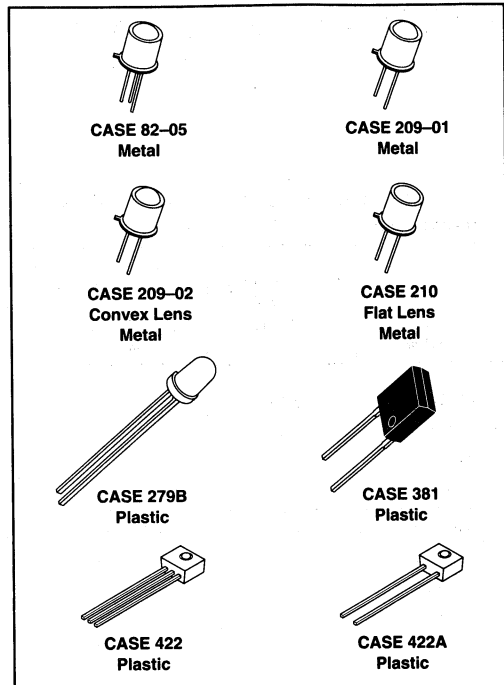

**Table 4. Photodarlington**

Device	Light Current @ $V_{CC} = 5$ , $H = 0.5$ mW/cm <sup>2</sup> mA (Typ)	$V_{(BR)CEO}$ Volts (Min)	$t_r/t_f$ @ $V_{CC} = 5$ V $\mu$ s (Typ)	Case/ Style
MRD370	10	40	15/40	82-05/1
MRD360	20	40	15/65	
<b>MRD911</b>	25	60	125/150	422A/2

**Table 5. Photo Schmitt Triggers**

Device	Threshold Current mA		$I_{F(off)}$ / $I_{F(on)}$ Typ	$V_{CC}$ Volts	$t_r/t_f$ $\mu$ s Typ	Case/ Style
	ON Max	OFF Min				
<b>MRD950</b>	20	1	0.75	3-15	0.1	422/3
MRD5009	20	1	0.75	3-15	0.1	82-05/1

Devices listed in bold, italic are Motorola preferred devices.

# Optointerrupters

An Optointerrupter consists of an infrared emitting diode facing a photodetector in a molded plastic housing. A slot in the housing between the emitter and detector provides a means for interrupting the signal transmission.

Motorola Optointerrupters are available in a wide selection of detector functions and housings to meet the designer's system requirements.

Motorola also offers custom designed packaging in a broad range of output functions, including those shown below, and more. Contact your nearest Motorola Sales Office or call us at 602-BIG-OPTO.

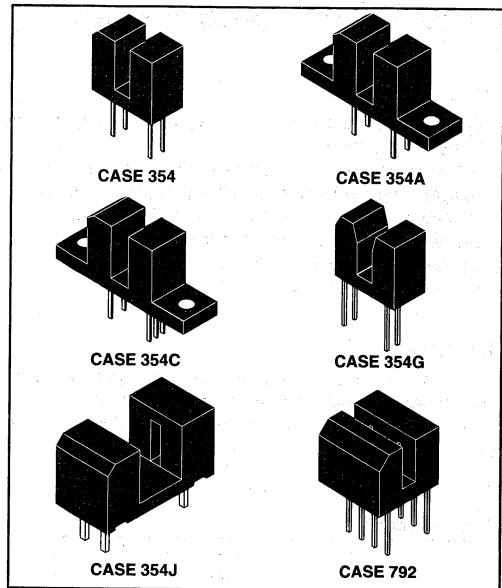

Table 1. Transistor

Device	Current Transfer Ratio			VCE(sat)			VF		Output Voltage Range Volts Max	Package Case/Style
	% Min	@ IF mA	VCE Volts	Volts Max	@ IF mA	IC mA	Volts Max	@ IF mA		
H21A1	5	20	5	0.4	30	1.8	1.7	60	30	354A/1
H21A2	10	20	5	0.4	20	1.8	1.7	60	30	354A/1
H21A3	20	20	5	0.4	20	1.8	1.7	60	30	354A/1
H22A1	5	20	5	0.4	30	1.8	1.7	60	30	354/1
H22A2	10	20	5	0.4	20	1.8	1.7	60	30	354/1
H22A3	20	20	5	0.4	20	1.8	1.7	60	30	354/1
<b>MOC70T1</b>	5	20	10	0.4	30	1.8	1.8	50	30	354A/1
<b>MOC70T2</b>	10	20	10	0.4	20	1.8	1.8	50	30	354A/1
MOC70P1	5	20	10	0.4	30	1.8	1.8	50	30	354J/1
MOC70P2	10	20	10	0.4	20	1.8	1.8	50	30	354J/1
<b>MOC70U1</b>	5	20	10	0.4	30	1.8	1.8	50	30	354G/1
<b>MOC70U2</b>	5	20	10	0.4	30	1.8	1.8	50	30	354G/1
MOC70V1	5	20	10	0.4	30	1.8	1.8	50	30	354G/1

Table 2. Dual Channel — Transistor

MOC70W1	0.5	20	10	0.4	20	0.1	1.8	50	30	792/2
---------	-----	----	----	-----	----	-----	-----	----	----	-------

Table 3. Darlington

H21B1	75	10	1.5	1	10	1.8	1.7	60	30	354A/1
H22B1	75	10	1.5	1	10	1.8	1.7	60	30	354/1
<b>MOC71U1</b>	75	20	1.5	1	10	1.8	1.7	60	30	354G/1

Table 4. Dual Channel — Darlington

<b>MOC71W1</b>	75	20	1.5	1	10	1.8	1.7	60	30	792/2
----------------	----	----	-----	---	----	-----	-----	----	----	-------

Table 5. Logic

Device	LED Trigger Current mA	Hysteresis Ratio IF(off)/IF(on)	t(on)/t(off) μs	VF		Output Voltage Range Volts	Package Case/Style
				Volts Max	@ IF mA		
<b>MOC75T1</b>	30	0.75	1.2	1.6	20	3-15	354C/1
<b>MOC75U1</b>	30	0.75	1.2	1.6	20	3-15	354C/1

Devices listed in bold, italic are Motorola preferred devices.

# Fiber Optic Components

## Emitters

Motorola offers emitters for fiber optics systems in both 660 nm and 850 nm.

- "POF" family in unique Plastic Optic Fiber package is designed for applications requiring low cost, speeds up to 10 MHz and distances under 200 meters. (The POF package serves as its own connector.) It is used with inexpensive 1000 micron plastic core fiber (Eskal SH4001).

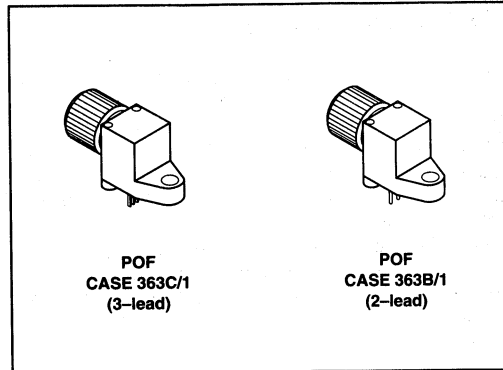

## Detectors

Detectors are available with a variety of output configurations that greatly affect Bandwidth and Responsivity.

All Motorola fiber optic components are designed for use with 1000 micron plastic core fiber.

Table 1. Emitters

Device	Total Power Output		Response Time		$\lambda$ nm Typ	Case/Style
	mW Typ	@ I <sub>F</sub> mA	t <sub>r</sub> ns Typ	t <sub>f</sub> ns Typ		
<b>MFOE71</b>	3.5	100	25	25	820	363B/1
<b>MFOE76</b>	3.5	100	200	150	660	

5

Table 2. Detectors

Device	BWE MHz	Responsivity $\mu\text{A}/\mu\text{W}$ Typ	Response Time $\mu\text{s}$ Typ		V(BR) Volts Min	Case/Style
			t <sub>on</sub> t <sub>r</sub>	t <sub>off</sub> t <sub>f</sub>		
<b>Photo PIN Diodes</b> MFOD71	70	0.2	1* ns	1* ns	100	363B/3
Phototransistors MFOD72	6 kHz	125	10*	60*	30	363B/2
Photodarlington MFOD73	2 kHz	1500	125*	150*	60	363B/2

Table 3. Logic Detector

Device	LED Trigger Current	Hysteresis Ratio	t <sub>on</sub> /t <sub>off</sub>	Light to Trigger	Case/Style
<b>Photologic Detector</b> MFOD75	30 mA	0.75	1.2	6 $\mu\text{W}$	363C/1

Devices listed in bold, italic are Motorola preferred devices.

# Sensors

---

## In Brief . . .

### Pressure Sensors

The marriage of integrated circuit technology with the most advanced pressure sensor architecture now offers an unrivaled combination of performance, reliability and design adaptability in a single monolithic pressure sensing element — the Motorola MPX series of pressure transducers. Available in three versions:

- Fully signal conditioned for high-level output (single chip device designed to compete with modules);
- Temperature compensated and calibrated, for simplified circuit design;
- Uncompensated for unlimited adaptability

This series of sensors provides both electrical and mechanical design-in options that uniquely fit the varying requirements of the system designer.

### Temperature Sensors

The sensitivity of a semiconductor junction to variation in temperature is utilized in a series of temperature-calibrated transistors that provide high temperature accuracy ( $\pm 2\%$  over a temperature range from  $-40^\circ$  to  $+150^\circ\text{C}$  at low cost).

	<b>Page</b>
Pressure Sensors . . . . .	5.9-2
Introduction . . . . .	5.9-2
The Basic Structure . . . . .	5.9-2
Motorola's Patented X-ducer . . . . .	5.9-2
Linearity . . . . .	5.9-3
Operation . . . . .	5.9-3
Electrical Characteristics . . . . .	5.9-4
Typical Electrical Characteristic Curves . . . . .	5.9-5
Unibody Cross-sectional Drawings . . . . .	5.9-5
Packaging Options . . . . .	5.9-6
Pressure Side Identification . . . . .	5.9-7
Ordering Information . . . . .	5.9-8
Silicon Temperature Sensors . . . . .	5.9-12



# Pressure Sensors

## Introduction

Motorola pressure sensors combine advanced piezoresistive sensor architecture with integrated circuit technology to offer a wide range of pressure sensing devices for automotive, biomedical, consumer and industrial applications. Selection versatility includes choice of:

### Pressure Ranges in PSI

0 to 1.5, 0 to 7.3, 0 to 14.5, 0 to 29, 0 to 100

### Sensing Options

Uncompensated, Temperature Compensated/Calibrated, High Impedance, and Signal Conditioned (with on-chip amplifiers)

### Application Measurements

Absolute, Differential, Gauge

### Package Options

Basic Element, Ported Elements for specific measurements

## The Basic Structure

The Motorola pressure sensor is designed utilizing a monolithic silicon piezoresistor, which generates a changing output voltage with variations in applied pressure. The resistive element, which constitutes a strain gauge, is ion implanted on a thin silicon diaphragm.

Applying pressure to the diaphragm results in a resistance change in the strain gauge, which in turn causes a change in the output voltage in direct proportion to the applied pressure. The strain gauge is an integral part of the silicon diaphragm, hence there are no temperature effects due to differences in thermal expansion of the strain gauge and the diaphragm. The output parameters of the strain gauge itself are temperature dependent, however, requiring that the device be compensated if used over an extensive temperature range. Simple resistor networks can be used for narrow temperature ranges, i.e., 0°C to 85°C. For temperature ranges from -40°C to +125°C, more extensive compensation networks are necessary.

## Motorola's Patented X-ducer™

Excitation current is passed longitudinally through the resistor (taps 1 and 3), and the pressure that stresses the diaphragm is applied at a right angle to the current flow. The stress establishes a transverse electric field in the resistor that is sensed as voltage at taps 2 and 4, which are located at the midpoint of the resistor. The single-element transverse voltage strain gauge can be viewed as the mechanical analog of a Hall effect device.

Using a single element eliminates the need to closely match the four stress and temperature sensitive resistors that form a Wheatstone bridge design. At the same time, it greatly simplifies the additional circuitry necessary to accomplish calibration and temperature compensation. The offset does not depend on matched resistors but instead on how well the transverse voltage taps are aligned. This alignment is accomplished in a single photolithographic step, making it easy to control, and is only a positive voltage, simplifying schemes to zero the offset.

5

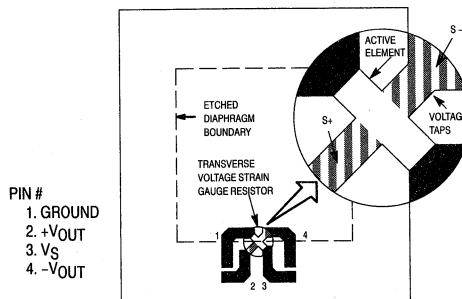

Figure 1. Basic Uncompensated Sensor Element — Top View

# Linearity

Linearity refers to how well a transducer's output follows the equation:  $V_{out} = V_{off} + \text{sensitivity} \times P$  over the operating pressure range. There are two basic methods for calculating nonlinearity: (1) end point straight line fit (see Figure 2) or (2) a least squares best line fit. While a least squares fit gives the "best case" linearity error (lower numerical value), the calculations required are burdensome.

Conversely, an end point fit will give the "worst case" error (often more desirable in error budget calculations) and the calculations are more straightforward for the user. Motorola's specified pressure sensor linearities are based on the end point straight line method measured at the midrange pressure.

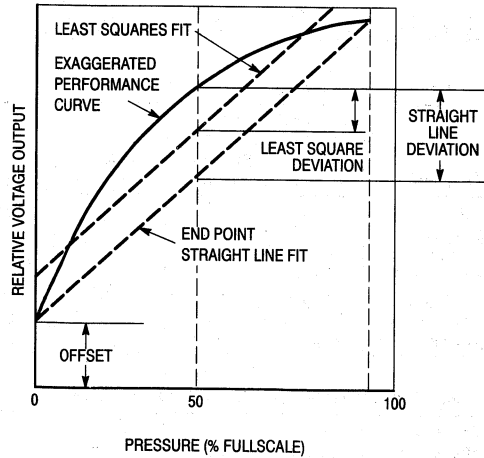

Figure 2. Linearity Specification Comparison

# Operation

Motorola pressure sensors support three types of pressure measurements: Absolute Pressure, Differential Pressure and Gauge Pressure.

**Absolute Pressure Sensors** measure an external pressure relative to a zero-pressure reference (vacuum) sealed inside the reference chamber of the die during manufacture. This corresponds to a deflection of the diaphragm equal to approximately 14.5 psi (one atmosphere), generating a quiescent full-scale output for the MPX100A (14.5 psi) sensor, and a half-scale output for the MPX200A (29 psi) device. Measurement of external pressure is accomplished by applying a relative negative pressure to the "Pressure" side of the sensor.

**Differential Pressure Sensors** measure the difference between pressures applied simultaneously to opposite sides of the diaphragm. A positive pressure applied to the "Pressure" side generates the same (positive) output as an equal negative pressure applied to the "Vacuum" side.

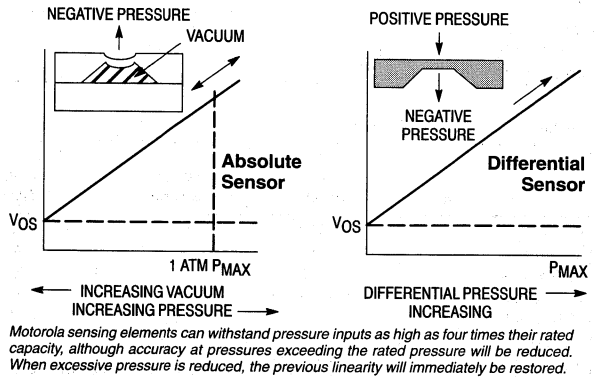

Motorola sensing elements can withstand pressure inputs as high as four times their rated capacity, although accuracy at pressures exceeding the rated pressure will be reduced. When excessive pressure is reduced, the previous linearity will immediately be restored.

Figure 3. Pressure Measurements

**Gauge Pressure** readings are a special case of differential measurements in which the pressure applied to the Pressure side is measured against the ambient atmospheric pressure applied to the Vacuum side through the vent hole in the chip of the differential pressure sensor elements.

5

# Electrical Characteristics

**Table 1. Uncompensated**

Device Series	Pressure Range kPa/psi (Max)	Over Pressure (kPa)	Offset mV (Typ)	Full Scale Span mV (Typ)	Sensitivity (mV/kPa) (Typ)	Linearity % of FSS <sup>(1)</sup>		Temperature Coefficient of Span %/°C (Typ)	Input Impedance Ohms (Typ)
						(Min)	(Max)		
MPX10D	10/1.5	100	20	35	3.5	-1	1	-0.19	475
MPX12D	10/1.5	100	20	55	5.5	0	5	-0.19	475
MPX50D	50/7.3	200	20	60	1.2	-0.1	0.1	-0.19	475
MPX100D,A	100/14.5	200	20	60	0.6	-0.1	0.1	-0.19	475
MPX200D,A	200/29	400	20	60	0.3	-0.25	0.25	-0.19	475
MPX201D,A	200/29	400	20	60	0.3	-0.35	0.35	-0.19	475
MPX700D	700/100	2100	20	60	0.086	-0.50	0.50	-0.18	475

**Table 2. Compensated and Calibrated (On-Chip)**

						% FSS			
<b><i>MPX2010D</i></b>	10/1.5	75	±0.05	25	2.5	-1.0	1.0	±0.5	1800
<b><i>MPX2050D</i></b>	50/7.3	200	±0.05	40	0.8	-0.25	0.25	±0.5	1800
<b><i>MPX2052D</i></b>	50/7.3	200	±0.1	40	0.8	-0.55	0.25	±0.5	1800
<b><i>MPX2100D,A</i></b>	100/14.5	400	±0.05	40	0.4	-0.25	0.25	±0.5	1800
<b><i>MPX2200D,A</i></b>	200/29	400	±0.05	40	0.2	-0.25	0.25	±0.5	1800
<b><i>MPX2700D</i></b>	700/100	2100	±0.05	40	0.057	-0.5	0.5	±0.5	1800

**Table 3. High Impedance**

<b><i>MPX7050D</i></b>	50/7.3	400	±0.1	40	0.8	-0.25	0.25	±0.5	10K
<b><i>MPX7100D,A</i></b>	100/14.5	400	±0.1	40	0.2	-0.25	0.25	±0.5	10K
<b><i>MPX7200D,A</i></b>	200/29	400	±0.1	40	0.2	-0.25	0.25	±0.5	10K

**Table 4. Signal Conditioned**

Device Series	Pressure kPa/psi (Max)	Voltage Source	Full Scale Span V (Typ)	Sensitivity (mV/kPa) (Typ)	Accuracy (0–85°C)
MPX4100A	105/15.5	5.1	4.59	54	1.5%
MPX4101A	102/15.2	5.1	4.70	54	1.5%
MPX4115A	115/17	5.1	4.59	54	1.5%
MPX4250A	250/35	5.1	4.69	58	1.5%
MPX5050D	50/7.3	5.0	4.70	90	2.5%
MPX5100A	115/17	5.0	4.50	45	2.5%
MPX5100D	100/14.5	5.0	4.50	45	2.5%

**Table 5. Temperature Sensors**

Device Series	V(BR)EBO Min Vdc	VBE mV (Typ)	ΔVBE mV	ΔT °C	T <sub>C</sub> mV/°C (Typ)
MTS102	4	595	3	2	-2.265
MTS105	4	595	7	5	-2.265

<sup>(1)</sup>Based on end point straight line fit method. Best fit straight line linearity error is approximately 1/2 of listed value.

Devices listed in bold, italic are Motorola preferred devices.

# Typical Electrical Characteristic Curves

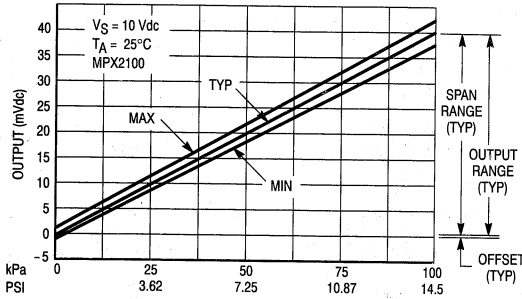

Figure 4. Output versus Pressure Differential

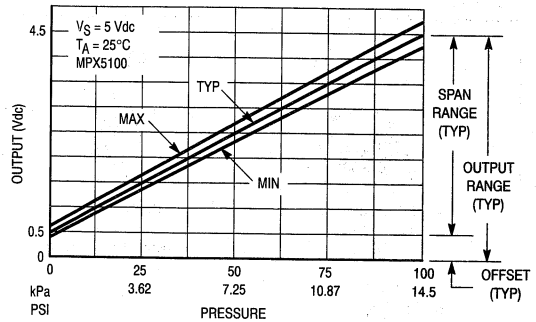

Figure 5. Signal Conditioned MPX5100

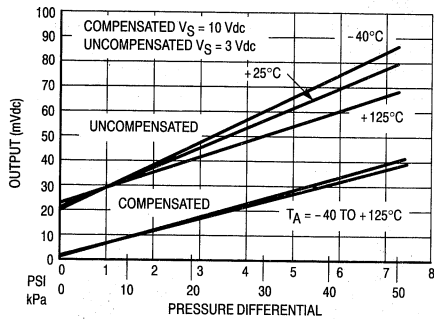

Figure 6. Typical-Output Voltage versus Pressure and Temperature for Compensated and Uncompensated Devices

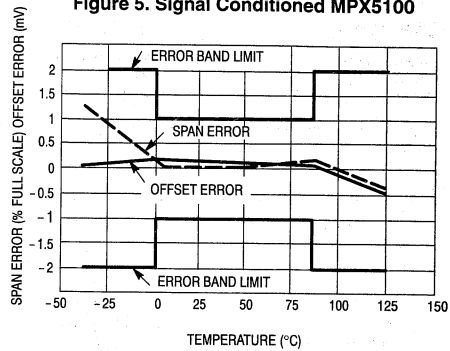

Figure 7. Temperature Error Band Limit and Typical Span and Offset Errors — Compensated Devices

5

## Unibody Cross-sectional Drawings

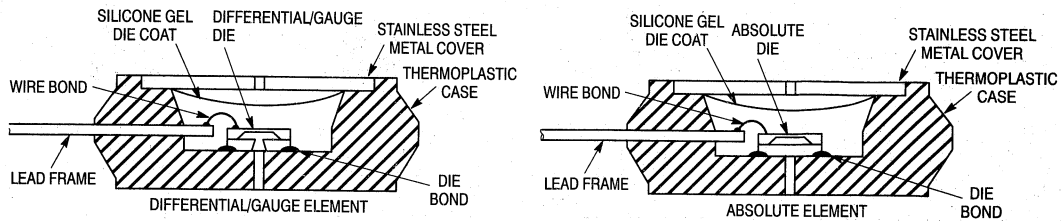

Figure 8. Cross-Sectional Diagrams (not to scale)

Figure 8 illustrates the absolute sensing configuration (right) and the differential or gauge configuration in the basic chip carrier (Case 344). A silicone gel isolates the die surface and wire bonds from harsh environments, while allowing the pressure signal to be transmitted to the silicon diaphragm.

The MPX series pressure sensor operating characteristics and internal reliability and qualification tests are based on use of dry air as the pressure media. Media other than dry air may have adverse effects on sensor performance and long term stability. Contact the factory for information regarding media compatibility in your application.

# Packaging Options

## 4-PIN



**BASIC ELEMENT**  
CASE 344  
SUFFIX A/D

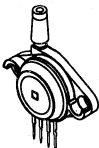

**GAUGE PORT**  
CASE 350-03  
SUFFIX AP/GP

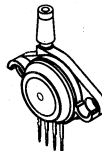

**GAUGE VACUUM PORT**  
CASE 350-04  
SUFFIX GVP



**DUAL PORT**  
CASE 352  
SUFFIX DP

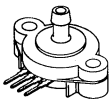

**AXIAL PORT**  
CASE 371C  
SUFFIX ASX/GSX

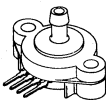

**AXIAL VACUUM PORT**  
CASE 371D  
SUFFIX GVSX



**STOVEPIPE PORT**  
CASE 371-05  
SUFFIX AS/GS



**STOVEPIPE VACUUM PORT**  
CASE 371-06  
SUFFIX GVS

## 6-PIN



**BASIC ELEMENT**  
CASE 867  
SUFFIX A/D

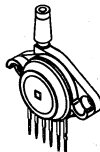

**GAUGE PORT**  
CASE 867B  
SUFFIX AP/GP

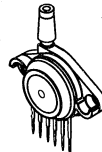

**GAUGE VACUUM PORT**  
CASE 867D  
SUFFIX GVP



**DUAL PORT**  
CASE 867C  
SUFFIX DP

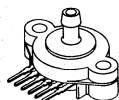

**AXIAL PORT**  
CASE 867F  
SUFFIX ASX/GSX

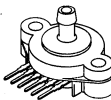

**AXIAL VACUUM PORT**  
CASE 867G  
SUFFIX GVSX



**STOVEPIPE PORT**  
CASE 867E  
SUFFIX AS/GS



**STOVEPIPE VACUUM PORT**  
CASE 867A  
SUFFIX GVS

5

# Pressure Side Identification

Motorola designates the two sides of the pressure sensor as the Pressure (top) side and the Vacuum Pressure (back) side. The Pressure side is the side containing silicone gel which protects the die from harsh media. The Motorola MPX

pressure sensor is designed to operate with positive differential pressure applied (i.e., top side pressure is greater than or equal to back side pressure). The Pressure side may be identified by using the example tables below.

**NOTE:** Stainless steel cap is not installed on devices with a port attached to the pressure (gel) side.

**Table 6. Pressure/Vacuum Side Identification**

Part Number	Case Type 4 PIN	Positive Pressure Side Identifier
MPXxxxxA MPXxxxxD	344	Stainless Steel Cap
MPXxxxxDP	352	Side with Part Marking
MPXxxxxAP MPXxxxxGP	350-03	Side with Port Attached
MPXxxxxGVP	350-04	Stainless Steel Cap
MPXxxxxAS MPXxxxxGS	371-06	Side with Port Attached
MPXxxxxGVS	371-05	Stainless Steel Cap
MPXxxxxASX MPXxxxxGSX	371C	Side with Port Attached
MPXxxxxGVSX	371D	Stainless Steel Cap
Part Number	Case Type 6 PIN	Positive Pressure Side Identifier
MPXxxxxA MPXxxxxD	867	Stainless Steel Cap
MPXxxxxDP	867C	Side with Part Marking
MPXxxxxAP MPXxxxxGP	867B	Side with Port Attached
MPXxxxxGVP	867D	Stainless Steel Cap
MPXxxxxAS MPXxxxxGS	867E	Side with Port Attached
MPXxxxxGVS	867A	Stainless Steel Cap
MPXxxxxASX MPXxxxxGSX	867F	Side with Port Attached
MPXxxxxGVSX	867G	Stainless Steel Cap

5

# Ordering Information

MPX series pressure sensors are available in absolute, differential and gauge configurations. Devices are available in the Basic Element package or with pressure port fittings which provide printed circuit board mounting ease and barbed hose pressure connections.

**Table 7. MPX10/50/100/200/700 Series (Uncompensated)**

Device Type	Measurement Options	Package Options	Pressure Range		
			0 – 1.5 PSI	0 – 7.3 PSI	0 – 14.5 PSI
4-Pin Basic Elements	Absolute	Case 344	—	—	MPX100A
	Differential	Case 344	MPX10D	MPX50D	MPX100D
Ported Elements	Absolute Port	Case 350-03	—	—	MPX100AP
	Absolute Stovepipe	Case 371-05	—	—	MPX100AS
	Absolute Axial	Case 371C	—	—	MPX100ASX
	Differential Port	Case 352	MPX10DP	MPX50DP	MPX100DP
	Gauge	Case 350-03	MPX10GP	MPX50GP	MPX100GP
	Gauge Vacuum	Case 350-04	MPX10GVP	MPX50GVP	MPX100GVP
	Gauge Stovepipe	Case 371-05	MPX10GS	MPX50GS	MPX100GS
	Gauge Vacuum Stovepipe	Case 371-06	MPX10GVS	MPX50GVS	MPX100GVS
	Gauge Axial	Case 371C	MPX10GSX	MPX50GSX	MPX100GSX
	Gauge Vacuum Axial	Case 371D	MPX10GVSX	MPX50GVSX	MPX100GVSX

**Table 7. MPX10/50/100/200/700 Series (Uncompensated) (continued)**

Device Type	Measurement Options	Package Options	Pressure Range	
			0 – 29 PSI	0 – 100 PSI
4-Pin Basic Elements	Absolute	Case 344	MPX200A	MPX700A
	Differential	Case 344	MPX200D	MPX700D
Ported Elements	Absolute Port	Case 350-03	MPX200AP	MPX700AP
	Absolute Stovepipe	Case 371-05	MPX200AS	MPX700AS
	Absolute Axial	Case 371C	MPX200ASX	MPX700ASX
	Differential Port	Case 352	MPX200DP	MPX700DP
	Gauge	Case 350-03	MPX200GP	MPX700GP
	Gauge Vacuum	Case 350-04	MPX200GVP	MPX700GVP
	Gauge Stovepipe	Case 371-05	MPX200GS	MPX700GS
	Gauge Vacuum Stovepipe	Case 371-06	MPX200GVS	MPX700GVS
	Gauge Axial	Case 371C	MPX200GSX	MPX700GSX
	Gauge Vacuum Axial	Case 371D	MPX200GVSX	MPX700GVSX

**5**

## Ordering Information (continued)

**Table 8. MPX2000 Series (Temperature Compensated and Calibrated On-Chip)**

Device Type	Measurement Options	Package Options	Pressure Range		
			0 – 1.5 PSI	0 – 7.3 PSI	0 – 7.3 PSI
4-Pin Basic Elements	Absolute	Case 344	—	—	—
	Differential	Case 344	<i>MPX2010D</i>	MPX2050D	MPX2052D
Ported Elements	Absolute Port	Case 350-03	—	—	—
	Absolute Stovepipe	Case 371-05	—	—	—
	Absolute Axial	Case 371C	—	—	—
	Differential Port	Case 352	<i>MPX2010DP</i>	MPX2050DP	MPX2052DP
	Gauge	Case 350-03	<i>MPX2010GP</i>	MPX2050GP	MPX2052GP
	Gauge Vacuum	Case 350-04	<i>MPX2010GVP</i>	MPX2050GVP	MPX2052GVP
	Gauge Stovepipe	Case 371-05	<i>MPX2010GS</i>	MPX2050GS	MPX2052GS
	Gauge Vacuum Stovepipe	Case 371-06	<i>MPX2010GVS</i>	MPX2050GVS	MPX2052GVS
	Gauge Axial	Case 371C	<i>MPX2010GSX</i>	MPX2050GSX	MPX2052GSX
	Gauge Vacuum Axial	Case 371D	<i>MPX2010GVSX</i>	MPX2050GVSX	MPX2052GVSX

**Table 9. MPX2100 Series (Temperature Compensated and Calibrated On-Chip)**

Device Type	Measurement Options	Package Options	Pressure Range	
			0 – 1.5 PSI	0 – 7.3 PSI
4-Pin Basic Elements	Absolute	Case 344	MPX2100A	MPX2200A
	Differential	Case 344	MPX2100D	MPX2200D
	Absolute Stovepipe	Case 371-05	MPX2100AS	MPX2200AS
	Absolute Axial	Case 371C	MPX2100ASX	MPX2200ASX
	Differential Port	Case 352-02	MPX2100DP	MPX2200DP
	Gauge	Case 350-03	MPX2100GP	MPX2200GP
	Gauge Vacuum	Case 350-04	MPX2100GVP	MPX2200GVP
	Gauge Stovepipe	Case 371-05	MPX2100GS	MPX2200GS
	Gauge Vacuum Stovepipe	Case 371-06	MPX2100GVS	MPX2200GVS
	Gauge Axial	Case 371C	MPX2100GSX	MPX2200GSX
	Gauge Vacuum Axial	Case 371D	MPX2100GVSX	MPX2200GVSX

5

Devices listed in bold, italic are Motorola preferred devices.



## Ordering Information (continued)

**Table 10. MPX4000 Series (Signal Conditioned On-Chip)**

Device Type	Measurement Options	Package Options	Pressure Range			
			20–105 kPa	15–102 kPa	20–115 kPa	20–250 kPa
<b>6-Pin</b> Basic Element	Absolute	Case 867	MPX4100A	MPX4101A	MPX4115A	MPX4250A
Ported Element	Absolute Stovepipe	Case 867B	MPX4100AP	MPX4101AP	MPX4115AP	MPX4250AP
	Absolute Axial	Case 867E	MPX4100AS	MPX4101AS	MPX4115AS	MPX4250AS
	Absolute Port	Case 867F	MPX4100ASX	MPX4101ASX	MPX4115ASX	MPX4250ASX

**Table 11. MPX5000 Series (Signal Conditioned On-Chip)**

Device Type	Measurement Options	Package Options	Pressure Range		
			0–7.3 PSI	0–14.5 PSI	2.5–17 PSI
<b>6-Pin</b> Basic Element	Absolute	Case 867	—	—	<b>MPX5100A</b>
	Differential	Case 867	<b>MPX5050D</b>	<b>MPX5100D</b>	—
Ported Element	Absolute Port	Case 867B	—	—	<b>MPX5100AP</b>
	Absolute Stovepipe	Case 867E	—	—	<b>MPX5100AS</b>
	Absolute Axial	Case 867F	—	—	<b>MPX5100ASX</b>
	Differential Port	Case 867C	<b>MPX5050DP</b>	<b>MPX5100DP</b>	—
	Gauge	Case 867B	<b>MPX5050GP</b>	<b>MPX5100GP</b>	—
	Gauge Vacuum	Case 867D	<b>MPX5050GVP</b>	<b>MPX5100GVP</b>	—
	Gauge Stovepipe	Case 867E	<b>MPX5050GS</b>	<b>MPX5100GS</b>	—
	Gauge Vacuum Stovepipe	Case 867A	<b>MPX5050GVS</b>	<b>MPX5100GVS</b>	—
	Gauge Axial	Case 867F	<b>MPX5050GSX</b>	<b>MPX5100GSX</b>	—
	Gauge Vacuum Axial	Case 867G	<b>MPX5050GVSX</b>	<b>MPX5100GVSX</b>	—

5

**Table 12. MPX7000 Series (High Impedance On-Chip)**

Device Type	Measurement Options	Package Options	Pressure Range	Pressure Range	Pressure Range
			0–7.3 PSI	0–14.5 PSI	0–29 PSI
<b>4-Pin</b> Basic Elements	Absolute	Case 344	—	MPX7100A	MPX7200A
	Differential	Case 344	MPX7050D	MPX7100D	MPX7200D
Ported Elements	Absolute Port	Case 350–03	—	MPX7100AP	MPX7200AP
	Absolute Stovepipe	Case 371–05	—	MPX7100AS	MPX7200AS
	Absolute Axial	Case 371C	—	MPX7100ASX	MPX7200ASX
	Differential Port	Case 352	MPX7050DP	MPX7100DP	MPX7200DP
	Gauge	Case 350–03	MPX7050GP	MPX7100GP	MPX7200GP
	Gauge Vacuum	Case 350–04	MPX7050GVP	MPX7100GVP	MPX7200GVP
	Gauge Stovepipe	Case 371–05	MPX7050GS	MPX7100GS	MPX7200GS
	Gauge Vacuum Stovepipe	Case 371–06	MPX7050GVS	MPX7100GVS	MPX7200GVS
	Gauge Axial	Case 371C	MPX7050GSX	MPX7100GSX	MPX7200GSX
	Gauge Vacuum Axial	Case 371D	MPX7050GVSX	MPX7100GVSX	MPX7200GVSX

Devices listed in bold, italic are Motorola preferred devices.

## Ordering Information (continued)

**Table 13. Sample Kits**

Device	Pressure Range kPa/psi	Available	Description	Order Information	Cost
MPX2010DP	10/1.5	NOW	Device w/Literature	KITNOK29/D	—
MPX700DP	700/100	NOW	Device w/Literature	KITNOK32/D	—
MPX5100DP	100/14.5	NOW	Device w/Literature	KITMPX5100D/D	—
MPX5100AP		NOW	Device w/Literature	KITMPX5100A/D	—
MPX7100DP	100/14.5	NOW	Device w/Literature	KITMPX7100D/D	—
MPX7200DP	200/30	NOW	Device w/Literature	KITMPX7200D/D	—

**Table 14. Evaluation Kits\***

DEVB-114	100/15	NOW	Pressure Sensor w/Microprocessor	KITDEVB114/D	95.00
DEVB-147	100/15	NOW	Temperature Compensated Sensor	KITDEVB147/D	75.00
DEVB-160	100/15	NOW	Evaluation Board that Demonstrates a User-Friendly Circuit Frequency Output Sensor	KITDEVB160/D	95.00

Sample/Evaluation kits are available through Literature Distribution. \*Note that Evaluation Boards are available in limited quantities. Call 602-994-6561 to order.

**5**

# Silicon Temperature Sensors

Available in a standard (TO-92) plastic package, these temperature sensing transistor elements are suitable for applications in automotive, consumer and industrial products requiring low cost and high accuracy.

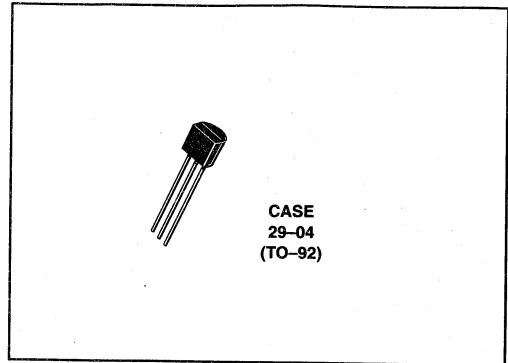

**Table 15. Silicon Temperature Sensors**

Device	$V_{BE}$ @ $I_C = 0.1 \text{ mA}$ , $T_A = 25^\circ\text{C}$ (Typ)	Temperature Over $-40^\circ\text{C}$ to $150^\circ\text{C}$	Thermal Time Constant		Case
			Liquid-to-Liquid (Typ)	Flowing Air (Typ)	
MTS102	595 mV	$\pm 2^\circ\text{C}$	3 s	8 s	29-04
MTS105	595 mV	$\pm 5^\circ\text{C}$	3 s	8 s	29-04

5

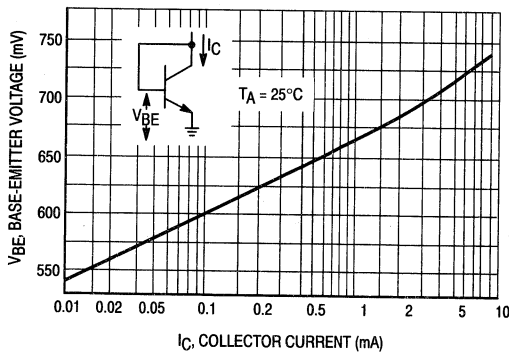

**Figure 1. Base-Emitter Voltage versus Collector-Emitter Current**

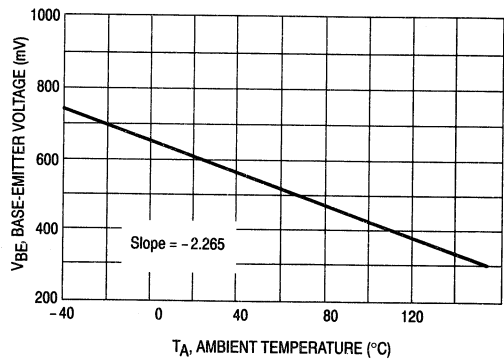

**Figure 2. Base-Emitter Voltage versus Ambient Temperature**

# RF Products

---

## In Brief . . .

While Motorola is considered to be the supermarket for semiconductor products, there is not a category in which the selection is more diverse, or more complete, than in products designed for RF system applications. From MOS and bipolar power and signal transistors, Motorola's RF components cover the entire spectrum from HF to microwave. Yet, product expansion continues — not only to keep pace with the progressive needs of the industry, but to better serve the needs of designers for a reliable and comprehensive source of supply.

Motorola has taken three major steps to continue leading the industry in supplying RF products. The first step taken was the acquisition of the RF Devices Division of TRW which occurred in 1988; the second step was the creation of an RF Integrated Circuits group within the RF Products Division which occurred in late 1990; and the third step was the recent investment of a major GaAs fabrication facility which was announced in 1991.

Acquiring the RF products of TRW has expanded Motorola's portfolio particularly in the area of high power linear transistors and microwave devices. These products can be found in the current listing of Motorola RF devices. The acquisition, which included a major design and manufacturing facility in France, has positioned Motorola for increased participation in the European market and particularly for significant participation in the greater European common market.

The creation of an integrated circuits group dedicated exclusively to RFICs emphasizes the importance that Motorola places on these devices for future needs in RF, particularly the trends to higher frequency, lower power RF commercial applications. And GaAs products — both discrete and IC — will play an increasing role in this market place of the future. The current list of RF products does not reflect the GaAs products that are in various stages of development. An initial listing of RFIC products has been added. The RFICs portfolio will be expanding to include several new products currently in development. For a detailed description of these products, consult your Motorola sales representative or distributor.

	<b>Page</b>
RF Discrete Transistors . . . . .	5.10-2
RF Power MOSFETs . . . . .	5.10-4
RF Power Bipolar Transistors . . . . .	5.10-6
HF Transistors . . . . .	5.10-6
VHF Transistors . . . . .	5.10-6
UHF Transistors . . . . .	5.10-7
900 MHz Transistors . . . . .	5.10-8
1.5 GHz Transistors . . . . .	5.10-10
Microwave Transistors . . . . .	5.10-10
Linear Transistors . . . . .	5.10-12
RF Small Signal Bipolar Transistors . . . . .	5.10-14
Selection by Package . . . . .	5.10-15
Plastic SOE Case . . . . .	5.10-15
Ceramic SOE Case . . . . .	5.10-17
Selection by Application . . . . .	5.10-18
RF Integrated Circuits . . . . .	5.10-20
To 1.0 GHz . . . . .	5.10-21
To 1.8 GHz . . . . .	5.10-22
RF Amplifiers . . . . .	5.10-23
High Power . . . . .	5.10-25
Land Mobile/Portable . . . . .	5.10-25
TV Transmitters . . . . .	5.10-26
Low Power . . . . .	5.10-27
CATV Distribution . . . . .	5.10-27
CRT Drivers . . . . .	5.10-30



# RF Discrete Transistors

In the following pages, the reader will find the most extensive group of RF Discrete Transistors offered by any semiconductor manufacturer anywhere in the world today.

From Bipolar to FET, from Low Power to High Power, the user can choose from a variety of packages. They include plastic, metal can and ceramic that are microstrip circuit compatible or surface mountable. Many are designed for automated assembly equipment.

Major sub-headings are MOSFETs, Power Bipolar and Small Signal Bipolar.

**5**

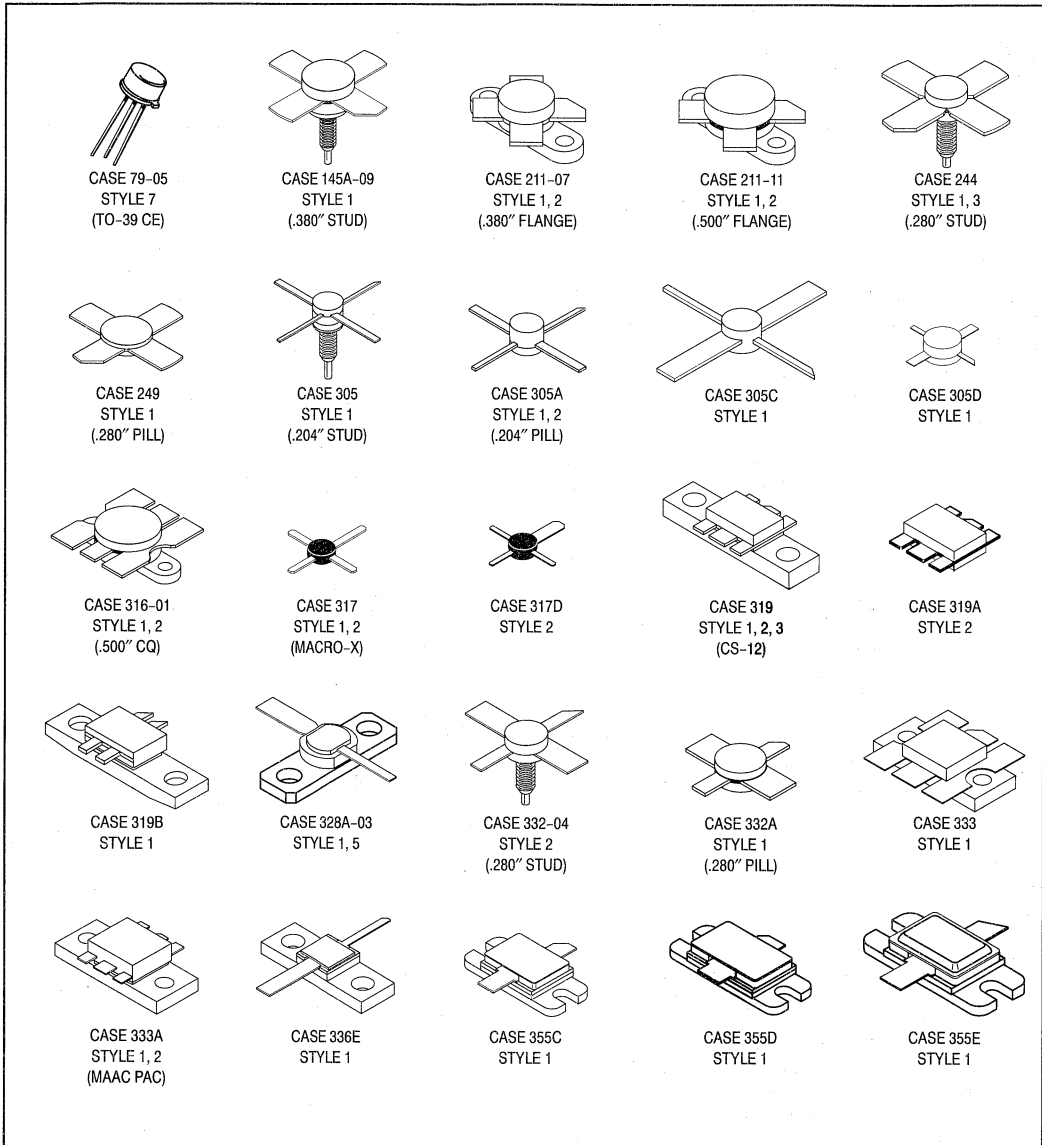

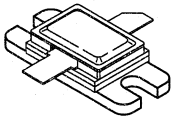

CASE 355G  
STYLE 1

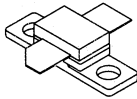

CASE 360A  
STYLE 1

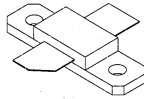

CASE 360B  
STYLE 1

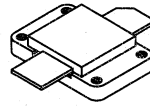

CASE 368  
STYLE 2  
(HOG PAC)

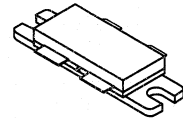

CASE 375  
STYLE 1, 2

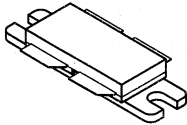

CASE 375A  
STYLE 1

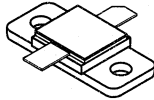

CASE 376B  
STYLE 1

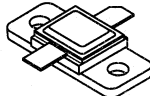

CASE 376C  
STYLE 1

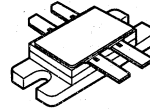

CASE 382  
STYLE 1

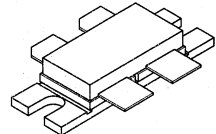

CASE 390B  
STYLE 1

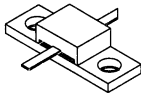

CASE 394  
STYLE 1

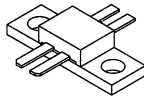

CASE 395  
STYLE 1

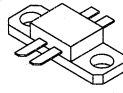

CASE 395B  
STYLE 1

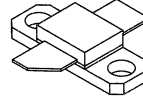

CASE 395C  
STYLE 1

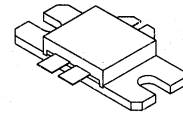

CASE 398  
STYLE 1

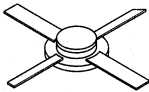

CASE 400  
STYLE 1

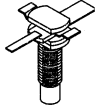

CASE 401  
STYLE 1

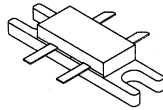

CASE 412  
STYLE 1



CASE 430  
STYLE 2

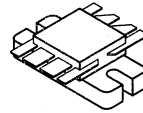

CASE 744A  
STYLE 1, 2



CASE 751  
STYLE 1  
(SO-8)

5

# RF Power MOSFETs

Motorola RF Power MOSFETs are constructed using a planar process to enhance manufacturing repeatability. They are *N-channel field effect transistors* with an oxide insulated gate which controls vertical current flow.

Compared with bipolar transistors, RF Power FETs exhibit higher gain, higher input impedance, enhanced thermal stability and lower noise. The FETs listed in this section are specified for operation in RF Power Amplifiers and are grouped by frequency range of operation and type of application. Arrangement within each group is first by order of voltage then by increasing output power.

**Table 1. To 150 MHz HF/SSB**

For military and commercial HF/SSB fixed, mobile, and marine transmitters.

Device	P <sub>out</sub> Output Power Watts	P <sub>in</sub> Input Power Typical Watts	G <sub>ps</sub> Typical Gain dB @ 30 MHz	Typical IMD		θ <sub>JC</sub> °C/W	Package/Style
				d <sub>3</sub> dB	d <sub>11</sub> dB		

**V<sub>DD</sub> = 28 Volts**

MRF138	30	0.6	17	-30	-60	1.5	211-07/2
MRF140	150	4.7	15	-30	-60	0.6	211-11/2

**V<sub>DD</sub> = 50 Volts**

MRF148	30	0.5	18	-35	-60	1.5	211-07/2
MRF150	150	2.9	17	-32	-60	0.6	211-11/2
MRF154	600	12	17	-25	—	0.13	368/2
<b>MRF157</b>	600	6	20	-25	—	0.13	368/2

**Table 2. To 225 MHz VHF AM/FM**

For VHF military and commercial aircraft radio transmitters.

Device	P <sub>out</sub> Output Power Watts	P <sub>in</sub> Input Power Typical Watts	G <sub>ps</sub> (Typ)/Freq. dB/MHz	η Efficiency Typical %	θ <sub>JC</sub> °C/W	Package/Style
--------	---	--	---------------------------------------	---------------------------------	-------------------------	---------------

**V<sub>DD</sub> = 28 Volts**

MRF134	5	0.2	14/150	55	10	211-07/2
MRF136	15	0.38	16/150	60	3.2	211-07/2
MRF166	20	0.5	16/150	60	3.2	211-07/2
MRF136Y	30	1.2	14/150	54	1.8	319B/1
MRF137	30	0.75	16/150	60	1.8	211-07/2
MRF171	45	1.4	15/150	60	1.5	211-07/2
<b>MRF173</b>	80	4	13/150	65	0.8	211-11/2
<b>MRF173CQ</b>	80	4	13/150	65	0.8	316-01/2
<b>MRF175LV</b>	100	4	14/225	65	0.65	333/1
MRF174	125	8.3	11.8/150	60	0.65	211-11/2
<b>MRF141</b>	150	10	10/175	55	0.6	211-11/2
<b>MRF175GV</b>	200	8	14/225	65	0.44	375/2
<b>MRF141G</b>	300	13	10/175	55	0.35	375/2

**V<sub>DD</sub> = 50 Volts**

MRF151	150	7.5	13/175	45	0.6	211-11/2
<b>MRF176GV</b>	200	4	17/225	55	0.44	375/2
<b>MRF151G</b>	300	7.5	16/175	55	0.35	375/2

Devices listed in bold, italic are Motorola preferred devices.

5

**Table 3. To 500 MHz UHF AM/FM**

For VHF/UHF military and commercial aircraft radio transmitters.

Device	P <sub>out</sub> Output Power Watts	P <sub>in</sub> Input Power Typical Watts	G <sub>ps</sub> (Typ)/Freq. dB/MHz	η Eff., Typ %	θ <sub>JC</sub> °C/W	Package/Style
<b>VDD = 28 Volts</b>						
<i>MRF158</i>	2	0.02	20/400	55	13.2	305A/2
MRF158R	2	0.02	20/400	55	22	79-05/7
MRF161	5	0.4	13.5/400	45	10	244/3
MRF162	15	0.65	13.6/400	50	3.5	244/3
<i>MRF166C</i>	20	0.4	17/400	55	2.5	319/3
<i>MRF164W</i>	20	0.4	17/400	50	1.5	412/1
MRF163	25	1.6	12/400	50	2	244/3
MRF175LU	100	10	10/400	55	0.65	333/1
MRF175GU	150	9.5	12/400	55	0.44	375/2
MRF177	100	6.4	12/400	60	0.65	744A/2
<i>MRF177M</i>	100	6.4	12/400	60	0.65	390B/1

**VDD = 50 Volts**

<i>MRF176GU</i>	150	6	14/400	50	0.44	375/2
-----------------	-----	---	--------	----	------	-------

**Table 4. To 520 MHz**

Designed for broadband VHF & UHF commercial and industrial applications. The high gain and broadband performance of these devices make them ideal for large-signal, common-source amplifier applications in 12.5 volt mobile and base station operation.

Device	P <sub>out</sub> Output Power Watts	P <sub>in</sub> (Max) Input Power Watts	G <sub>pE</sub> (Min)/Freq. Power Gain dB/MHz	θ <sub>JC</sub> °C/W	Package/Style
<b>VCC = 7.5 Volts</b>					
<i>MRF5003*</i>	3	0.336	10.5/512	14	430/2

**VCC = 12.5 Volts**

<i>MRF5015*</i>	15	1.3	11.5/512	3.5	319/3
<i>MRF5035*</i>	35	4.7	7.5/512	1.8	316-01/3

**Table 5. To 1.0 GHz**

For HF/VHF/UHF military and commercial radio transmitters.

Device	P <sub>out</sub> Output Power Watts	P <sub>in</sub> Input Power Typical Watts	G <sub>ps</sub> (Typ)/Freq. dB/MHz	η Eff., Typ %	θ <sub>JC</sub> °C/W	Package/Style
<b>VDD = 28 Volts</b>						
MRF182*	30	1.5	13/1000	55	2.1	360B/1
MRF183*	45	2.8	12/1000	55	1.5	360B/1

\*New Product

Devices listed in bold, italic are Motorola preferred devices.



# RF Power Bipolar Transistors

Motorola's broad line of bipolar RF power transistors are characterized for operation in RF power amplifiers. Typical applications are in military and commercial landmobile, avionics and marine radio transmitters. Groupings are by frequency band and type of application. Within each group, the arrangement of devices is by major supply voltage rating, then in the order of increasing output power. All devices are NPN polarity except where otherwise noted.

## HF Transistors

**Table 6. 1.5 – 30 MHz, HF/SSB**

Designed for broadband operation, these devices feature specified Intermodulation Distortion at rated power output. Applications include mobile, marine, fixed station, and amateur HF/SSB equipment, operating from 12.5, 13.6, 28, or 50 volt supplies.

Device	P <sub>out</sub> Output Power Watts	P <sub>in</sub> (Max) Input Power Watts	G <sub>PE</sub> (Min) Gain @ 30 MHz dB	θ <sub>JC</sub> °C/W	Package/Style
<b>VCC = 12.5 or 13.6 Volts</b>					
<b>MRF421</b>	100 PEP/CW	10	10	0.6	211–11/1
<b>VCC = 28 Volts</b>					
MRF426	25 PEP/CW	0.16	22	2.5	211–07/1
MRF464	80 PEP/CW	2.53	15	0.7	211–11/1
MRF422	150 PEP/CW	15	10	0.6	211–11/1
<b>VCC = 50 Volts</b>					
MRF429	150 PEP/CW	7.5	13	0.8	211–11/1
MRF448	250 PEP/CW	15.7	12	0.6	211–11/1

**Table 7. 14 – 30 MHz, CB/Amateur Band**

These HF transistors are designed for economical, high-volume use in CW, AM and SSB applications.

**VCC = 12.5 or 13.6 Volts**

<b>MRF455</b>	60	3	13	1	211–07/1
<b>MRF454</b>	80	5	12	0.7	211–11/1

**Table 8. 27 – 50 MHz, Low-Band FM Band**

For use in the FM "Low-Band," for Mobile communications.

Device	P <sub>out</sub> Output Power Watts	P <sub>in</sub> (Max) Input Power Watts	G <sub>PE</sub> (Min) Gain @ 50 MHz dB	θ <sub>JC</sub> °C/W	Package/Style
<b>VCC = 12.5 or 13.6 Volts</b>					
<b>MRF492</b>	70	5.6	11	0.7	211–11/1

## VHF Transistors

**Table 9. 30 – 200 MHz Band**

Designed for Military Radio and Commercial Aircraft VHF bands, these 28-volt devices include the all-gold metallized MRF314/15/16/17 high-reliability series.

Device	P <sub>out</sub> Output Power Watts	P <sub>in</sub> (Max) Input Power Watts	G <sub>PE</sub> (Min)/Freq. Power Gain dB/MHz	θ <sub>JC</sub> °C/W	Package/Style
<b>VCC = 28 Volts</b>					
MRF314	30	3	10/150	2.2	211–07/1
MRF315	45	5.7	9/150	1.6	211–07/1
MRF316(2)	80	8	10/150	0.8	316–01/1
MRF317(2)	100	12.5	9/150	0.65	316–01/1

(2) Internal Impedance Matched

Devices listed in bold, italic are Motorola preferred devices.

5

## VHF Transistors (continued)

**Table 10. 136 – 174 MHz High Band**

The "workhorse" VHF FM High-Band is served by Motorola with the broadest range of devices and package combinations in the industry.

Device	P <sub>out</sub> Output Power Watts	P <sub>in</sub> (Max) Input Power Watts	G <sub>pE</sub> (Min) Gain @ 175 MHz dB	θ <sub>JC</sub> °C/W	Package/Style
<b>VCC = 12.5 Volts</b>					
MRF4427	1	0.016	18(19)	125(1)	751/1
MRF553	1.5	0.11	11.5	25	317D/2
<b>MRF2628</b>	15	0.95	12	4	244/1
<b>MRF1946</b>	30	3	10	1.6	211-07/1
<b>MRF1946A</b>	30	3	10	1.8	145A-09/1
MRF224	40	14.3	4.5	2.2	211-07/1
MRF240	40	5	9	2.2	145A-09/1
<b>MRF247(2)</b>	75	15	7	0.7	316-01/1

## UHF Transistors

**Table 11. 100 – 400 MHz Band**

Stringent requirements of the UHF Military band are met by MRF325, 326, 327, 329 and 2N6439 types, with all-gold metal systems, specified ruggedness and programmed wirebond construction, to assure consistent input impedances for internally matched parts.

Device	P <sub>out</sub> Output Power Watts	P <sub>in</sub> (Max) Input Power Watts	G <sub>pE</sub> (Min) Gain @ 400 MHz dB	θ <sub>JC</sub> °C/W	Package/Style
<b>VCC = 28 Volts</b>					
MRF325(2)	30	4.3	8.5	2.2	316-01/1
MRF326(2)	40	8	9	1.6	316-01/1
2N6439(2)	60	10	7.8	1.2	316-01/1
MRF327(2)	80	14.9	7.3	0.7	316-01/1
MRF329(2)	100	20	7	0.7	333/1
<b>MRF392(3)</b>	125	19.8	8	0.7	744A/1
<b>2N6985(3)</b>	125	19.8	8	0.7	382/1

**Table 12. 100 – 500 MHz Band**

Similar to the 100–400 MHz transistors, these devices have bandwidth capabilities allowing their use to 500 MHz. All have nitride passivated die, gold metal systems, specified ruggedness and controlled wirebond construction to meet the stringent requirements of military space applications.

Device	P <sub>out</sub> Output Power Watts	P <sub>in</sub> (Max) Input Power Watts	G <sub>pE</sub> (Min)/Freq. Power Gain dB/MHz	θ <sub>JC</sub> °C/W	Package/Style
<b>VCC = 28 Volts</b>					
MRF313	1	0.03	15/400	28.5	305A/1
MRF321	10	0.62	12/400	6.4	244/1
MRF323	20	2	10/400	3.2	244/1
<b>MRF393(3)</b>	100	18	7.5/500	0.7	744A/1
<b>2N6986(3)</b>	100	18	7.5/500	0.7	382/1

(1) R<sub>θJA</sub>, Thermal Resistance Junction to Ambient

(2) Internal Impedance Matched

(3) Internal Impedance Matched Push-Pull Transistors

(19) Typical

Devices listed in bold, italic are Motorola preferred devices.

## UHF Transistors (continued)

**Table 13. 400 – 512 MHz Band**

Higher power output devices in this UHF power transistor series feature internally input-matched construction, are designed for broadband operation, and have guaranteed ruggedness under output mismatch and RF overdrive conditions. Devices are specified for handheld, mobile and base station operation.

Device	P <sub>out</sub> Output Power Watts	P <sub>in</sub> (Max) Input Power Watts	G <sub>PE</sub> (Min)/Freq. Power Gain dB/MHz	θ <sub>JC</sub> °C/W	Package/Style
--------	---	---	---	-------------------------	---------------

**VCC = 12.5 Volts**

<b>MRF581 (4)</b>	0.6	0.03	13/500	40	317/2
MRF555	1.5	0.15	10/470	25	317D/2
<b>MRF652</b>	5	0.5	10/512	7	244/1
MRF652S	5	0.5	10/512	7	249/1
<b>MRF653</b>	10	2	7/512	4	244/1
MRF653S	10	2	7/512	4	249/1
MRF641(2)	15	2.5	7.8/470	4	316-01/1
<b>MRF654 (2)</b>	15	2.5	7.8/512	4	244/1
MRF644(2)	25	5.9	6.2/470	1.7	316-01/1
<b>MRF650 (2)</b>	50	15.8	5.0/512	1.3	316-01/1
<b>MRF658 (2)</b>	65	25	4.15/512	1	316-01/1

**VCC = 24 Volts**

TP5002S	1.5	0.075	13/470	21	249-05/1
<b>TP5051</b>	50	6	9/470	1.2	333A/2

**5**

## 900 MHz Transistors

**Table 14. 870 – 960 MHz Band**

Designed specifically for the 900 MHz mobile radio band, types MRF840 through MRF847 offer superior gain and ruggedness, using the unique CS-12 package, which minimizes common-element impedance, and thus maximizes gain and stability. Devices are listed for mobile and base station applications.

Device	P <sub>out</sub> Output Power Watts	P <sub>in</sub> (Max) Input Power Watts	G <sub>PE</sub> (Min)/Freq. Power Gain dB/MHz	θ <sub>JC</sub> °C/W	Package/Style
--------	---	---	---	-------------------------	---------------

**VCC = 12.5 Volts — Class C — Si Bipolar**

MRF559(5)	0.5	0.08	8/870	50	317/2
<b>MRF581 (5)</b>	0.6	0.06	10(19)/870	40	317/2
MRF837(5)	0.75	0.11	8/870	40	317/1
<b>MRF8372 (5)</b>	0.75	0.11	8/870	45	751/1
<b>MRF557 (5)</b>	1.5	0.23	8/870	25	317D/2
MRF839F(5)	3	0.46	8/870	9	319/2
MRF840(2)(6)	10	2.5	6/870	3.1	319/1
MRF842(2)(6)	20	5	6/870	1.5	319/1
MRF844(2)(6)	30	9	5.2/870	1.5	319/1
<b>MRF847 (2)(6)</b>	45	16	4.5/870	1	319/1

(2)Internal Impedance Matched

(4)Small signal gain. P<sub>o</sub> is Typ.

(5)Common Emitter Configuration

(6)Common Base Configuration

(19)Typical

Devices listed in bold, italic are Motorola preferred devices.

## 900 MHz Transistors (continued)

Table 14. 800 – 960 MHz Band (continued)

Device	P <sub>out</sub> Output Power Watts	Class	P <sub>in</sub> (Max) Input Power Watts	G <sub>p</sub> (Min)/Freq. Power Gain dB/MHz	θ <sub>JC</sub> °C/W	Package/Style
--------	---	-------	---	--	-------------------------	---------------

### V<sub>CC</sub> = 24 Volts — Si Bipolar

MRF890	2	C	0.25	9/900	25	305/1
MRF890S	2	C	0.25	9/900	25	305A/1
TP3019S	2	AB or A	0.25	9/960	14	305A/1
TP3007S★	2	AB	0.25	9/960	21	305C/1
<b>MRF857★</b>	2.1 (CW)	A	0.4	12.5/900	8.4	305/1
<b>MRF857S★</b>	2.1 (CW)	A	0.4	12.5/900	8.4	305D/1
<b>MRF896</b>	3	AB or A	0.3	10/900	7	305/1
<b>MRF896S</b>	3	AB or A	0.3	10/900	7	305D/1
<b>MRF858★</b>	3.6 (CW)	A	0.85	11/900	6.9	319/2
TP3008★	4	AB	0.28	11.5/960	5	319/2
<b>MRF891</b>	5	AB	0.63	9/900	7	319/2
MRF891S	5	C	0.63	9/900	7	319A/2
<b>MRF860★</b>	13.7 (CW)	A	3.25	11/900	1.9	395B/1
MRF892(2)	14	C	2	8.5/900	3.5	319/1
<b>MRF861★</b>	27 (CW)	A	8	9.5/900	0.92	375A/1
MRF894(2)	30	C	6	7/900	1.5	319/1
<b>MRF897(3)</b>	30	AB	3	10/900	1.7	395B/1
TP3034★	35	AB	7	7/960	2.3	319/2
<b>MRF862★</b>	36 (CW)	A	13.6	9/900	0.75	375A/1
<b>MRF898(2)</b>	60	C	12	7/900	1	333A/1

### V<sub>CC</sub> = 26 Volts — Si Bipolar

TP3020A	2.2	A	0.28	9/960	20	244/1
TP3005	4	AB or A	0.57	8.5/960	7	319/2
TP3006	5	AB	0.63	9/960	7	319/2
TP3022B	15	AB	2.12	8.5/960	6	319/2
TP3032	21	AB	4	7.5/960	3.3	319/2
TP3024B(3)	35.5	AB	6.35	7.5/960	3	395/1
<b>TP3061(2)</b>	45	AB	7.13	8/960	1.2	333A/2
TP3064	50	AB	8.9	7.5/960	1.2	333A/2
TP3062(3)	60	AB	12	7/960	1.2	398/1
<b>MRF880(3)</b>	90	AB	12.7	8.5/900	1.3	375A/1
TP3069★	100	AB	18	7.5/960	0.7	375A/1
<b>MRF899(3)</b>	150	AB	24	8/900	0.8	375A/1

(2)Internal Impedance Matched

(3)Internal Impedance Matched Push-Pull Transistors

★New Product

5

Devices listed in bold, italic are Motorola preferred devices.

## 1.5 GHz Transistors

Table 15. 1400 – 1600 MHz Band

Device	P <sub>out</sub> Output Power Watts	Class	P <sub>in</sub> (Max) Input Power Watts	G <sub>p</sub> (Min)/Freq. Power Gain dB/MHz	θ <sub>JC</sub> °C/W	Package/Style
<b>MRF15030</b> ★	30	A, AB	3.1	9/1490	1.4	395C/1
<b>MRF15090</b> ★	90	A, AB	10.8	7.5/1490	0.7	375A/1

## Microwave Transistors

Table 16. L-Band Pulse Power

These products are designed to operate in short pulse width, 10 μs, low duty cycle, 1%, power amplifiers operating in the 960–1215 MHz band. All devices have internal impedance matching. The prime application is avionics equipment for distance measuring (DME), area navigation (TACAN) and interrogation (IFF).

Device	P <sub>out</sub> Output Power Watts	P <sub>in</sub> (Max) Input Power Watts	G <sub>p</sub> (Min) Gain @ 1090 MHz dB	θ <sub>JC</sub> °C/W	Package/Style
--------	---	---	---	-------------------------	---------------

V<sub>CC</sub> = 18 Volts — Class A & AB Common Emitter

MRF1000MA	0.2	0.02	10	25	332–04/2
<b>MRF1000MB</b>	0.2	0.02	10	25	332A/2

V<sub>CC</sub> = 35 Volts — Class B & C Common Base

MRF1002MA	2	0.2	10	25	332–04/1
<b>MRF1002MB</b>	2	0.2	10	25	332A/1
<b>MRF1004MA</b>	4	0.4	10	25	332–04/1
MRF1004MB	4	0.4	10	25	332A/1

V<sub>CC</sub> = 50 Volts — Class C Common Base

MRF1015MA	15	1.5	10	10	332–04/1
<b>MRF1015MB</b>	15	1.5	10	10	332A/1
MRF1035MA	35	3.5	10	5	332–04/1
<b>MRF1035MB</b>	35	3.5	10	5	332A/1
<b>MRF1090MA</b>	90	9	10	0.6	332–04/1
MRF1090MB	90	9	10	0.6	332A/1
<b>MRF1150MA</b>	150	25	7.8	0.3	332–04/1
MRF1150MB	150	25	7.8	0.3	332A/1

5

Table 17. L-Band Long Pulse Power

These products are designed for pulse power amplifier applications in the 960–1215 MHz frequency range. They are capable of handling up to 10 μs pulses in long pulse trains resulting in up to a 50% duty cycle over a 3.5 millisecond interval. Overall duty cycle is limited to 25% maximum. The primary applications for devices of this type are military systems, specifically JTIDS and commercial systems, specifically Mode S. Package types are hermetic.

Device	P <sub>out</sub> Output Power Watts	P <sub>in</sub> (Max) Input Power Watts	G <sub>p</sub> (Min) Gain @ 1215 MHz dB	θ <sub>JC</sub> °C/W	Package/Style
--------	---	---	---	-------------------------	---------------

V<sub>CC</sub> = 28 Volts — Class C Common Base

MRF10005	5	0.71	8.5	8	336E/1
----------	---	------	-----	---	--------

V<sub>CC</sub> = 36 Volts — Class C Common Base

<b>MRF10031</b>	30	3	10	3	376B/1
<b>MRF10120</b>	120	19	8	0.6	355C/1

★New Product

Devices listed in bold, italic are Motorola preferred devices.

## Microwave Transistors (continued)

**Table 17. L-Band Long Pulse Power (continued)**

Device	P <sub>out</sub> Output Power Watts	P <sub>in</sub> (Max) Input Power Watts	G <sub>PB</sub> (Min) Gain @ 1215 MHz dB	θ <sub>JC</sub> °C/W	Package/Style
<b>VCC = 50 Volts</b>					
<i>MRF10070</i>	70	7	10 <sup>(7)</sup>	0.4	376C/1
<i>MRF10150</i>	150	15	10 <sup>(7)</sup>	0.25	376B/1
<i>MRF10350</i>	350	45	9 <sup>(7)</sup>	0.11	355E/1
<i>MRF10500</i>	500	56	9 <sup>(7)</sup>	0.12	355D/1
<i>MRF1375</i>	375	80	6.7	0.12	355G/1
<i>MRF1500</i>	500	151	5.2	0.1	355G/1

**Table 18. 2 GHz Narrowband CW**

The MRW2000 Series of NPN Silicon microwave power transistors are designed for common base service in amplifier or oscillator applications in the 1–2.3 GHz frequency range.

Device	P <sub>out</sub> Output Power Watts	P <sub>in</sub> (Max) Input Power Watts	G <sub>PB</sub> (Min) Gain @ 2 GHz dB	θ <sub>JC</sub> °C/W	Package/Style
<b>VCC = 28 Volts — Class B &amp; C Common Base</b>					
MRW2001	1	0.13	9	35	328A–03/1
MRW2003	3	0.48	8	15	328A–03/1
MRW2005	5	0.8	8	8.5	328A–03/1
MRW2010	10	2	7	6	328A–03/1

**Table 19. 3 GHz Narrowband CW**

The MRW3000 Series are the industry's first 100% VSWR tolerant 3 GHz devices. They are common-base configured in hermetic packages and rated for 28 volt operation.

Device	P <sub>out</sub> Output Power Watts	P <sub>in</sub> (Max) Input Power Watts	G <sub>PB</sub> (Min) Gain @ 3.0 GHz dB	θ <sub>JC</sub> °C/W	Package/Style
<b>VCC = 28 Volts</b>					
MRW3001	1	0.2	7	35	328A–03/1
MRW3003	3	0.75	6	17	328A–03/1
MRW3005	5	1.6	5	8.5	328A–03/1

**Table 20. 0.6 – 2.7 GHz Broadband Common Base**

The MicRoAmp transistor employs MOS capacitors and other matching elements to transform the input, and in some devices, the output impedance, to a more manageable level prior to the point where package parasitics can reduce the bandwidth capability (U.S. Patent 3,713,006). These devices are assembled in common-base configuration and include an all-gold metal system and diffused ballast resistors for long life.

Device	Instantaneous Frequency Range F <sub>L</sub> –F <sub>H</sub> (MHz)	Output Power Min Watts	Gain Min dB	θ <sub>JF</sub> °C/W	Package/Style
<b>VCC = 22 Volts</b>					
MRAL1720–20	1700–2000	20	6	2.5	394/1
MRAL2023–3	2000–2300	3	8	16	394/1
MRAL2023–6	2000–2300	6	6.8	8	394/1
MRAL2023–18	2000–2300	18	6.5	2.5	394/1
MRAL2327–3	2300–2700	3	6.6	16	394/1
MRAL2327–12	2300–2700	12	7	4.5	394/1

**VCC = 28 Volts**

MRA1417–6	1400–1700	6	7.4	8	394/1
-----------	-----------	---	-----	---	-------

<sup>(7)</sup>Typical @ 1090 MHz

Devices listed in bold, italic are Motorola preferred devices.

## Microwave Transistors (continued)

**Table 21. Power Oscillator**

This oscillator device, a **common collector** configuration with diffused ballast resistors, gold metallization and hermetic package, provides high reliability in severe environmental conditions and is fully characterized for power oscillator applications.

Device	Operating Conditions V <sub>CE</sub> /I <sub>C</sub> V/mA	Output Power (Typ) — Watts/@ Freq. — GHz				Package/Style
		Minimum	P <sub>O</sub> @ Low f	P <sub>O</sub> @ Mid f	P <sub>O</sub> @ High f	
TP62601	20/220	1.25/2	1.85/2	1.35/2.5	0.85/3	328A-03/5

## Linear Transistors

The following sections describe a wide variety of devices specifically characterized for linear amplification. Included are medium power and high power parts covering frequencies from 100 MHz–4 GHz.

**Table 22. To 1 GHz, Class A**

These devices offer a selection of performance and price for linear amplification to 1 GHz. The "MRA" prefix parts are input matched and feature high overdrive and extreme ruggedness capability.

Device	P <sub>O</sub> @ 1 dB Comp. Point Watts	G <sub>SS</sub> (Min)/Freq. Small Signal Gain dB/MHz	Bias Point (Vdc/A)	θ <sub>JC</sub> °C/W	Package/Style
--------	---	--	--------------------------	-------------------------	---------------

**V<sub>CC</sub> = 19 Volts**

MRA1000-7L	7	9/1000	19/1.2	4	145A-09/1
MRA1000-14L	14	8/1000	19/2.4	2.1	145A-09/1

**V<sub>CC</sub> = 25 Volts**

MRF1029 <sup>(9)</sup>	1.5	8/1000	25/0.2	12	244/1
MRF1030 <sup>(9)</sup>	3	7.5/1000	25/0.4	6	244/1
MRF1031 <sup>(9)</sup>	4.5	7/1000	25/0.6	3.5	244/1
MRF1032 <sup>(9)</sup>	6	6.5/1000	25/0.85	3.5	244/1

5

**Table 23. To 2 GHz, Class A**

These parts offer low cost alternatives to matched devices used primarily as pre-drivers to 2 GHz.

Device	P <sub>O</sub> @ 1 dB Comp. Point Watts	G <sub>SS</sub> (Min)/Freq. Small Signal Gain dB/MHz	Bias Point (Vdc/A)	θ <sub>JC</sub> °C/W	Package/Style
--------	---	--	--------------------------	-------------------------	---------------

**V<sub>CC</sub> = 20 Volts**

<b>MRF3094<sup>(9)</sup></b>	0.5	10.5/2000	20/0.12	40	328A-03/1
<b>MRF3104<sup>(9)</sup></b>	0.5	10.5/2000	20/0.12	40	305A/1
<b>MRF3095<sup>(9)</sup></b>	0.8	9/2000	20/0.12	35	328A-03/1
<b>MRF3105<sup>(9)</sup></b>	0.8	9/2000	20/0.12	35	305A/1
<b>MRF3096<sup>(9)</sup></b>	1.6	9/2000	20/0.24	22	328A-03/1
<b>MRF3106<sup>(9)</sup></b>	1.6	9/2000	20/0.24	22	305A/1
<b>MRF2000-5L<sup>(10)</sup></b>	5	7/2000	19/0.6	10	360A/1

<sup>(9)</sup>Former Prefix was "RF"

<sup>(10)</sup>Former prefix was "MRA"

Devices listed in bold, italic are Motorola preferred devices.

## Linear Transistors (continued)

**Table 24. UHF Ultra Linear For TV Applications**

The following devices have been characterized for ultra-linear applications such as low-power TV transmitters in Band IV and Band V. Each features diffused ballast resistors and an all-gold metal system to provide enhanced reliability and ruggedness.

Device	$P_{ref}$ (Min) Watts	$G_p$ (Min)/Freq. Small Signal Gain dB/MHz	3 Tone IMD <sup>(8)</sup> dB	$\theta_{JC}$ °C/W	Package/Style
<b>VCC = 20 Volts</b>					
TPV596A	0.5	11.5/860	-58	20	244/1
TPV597	1	10.5/860	-58	9	244/1
TPV598	4	7/860	-60	5	244/1
<b>VCC = 25 Volts</b>					
TPV595A	14	8.5/860	-47	2.5	395/1
<b>TPV695A</b>	14	9.5/860	-47	2.5	395B/1
TPV7025	25	8.5/860	-45	1.5	398/1
TPV6030	20/35 <sup>(11)</sup>	9.5/860	-51/-	1.1	375A/1
<b>VCC = 28 Volts</b>					
<b>TPV8100B</b>	100 <sup>(11)</sup>	8.5/860	—	0.7	398/1
<b>TPV8200B</b>	150 <sup>(11)</sup>	8/860	—	0.7	375A/1

**Table 25. Microwave Linear For PCN Applications**

The following devices have been developed for linear amplifiers in the 1.5–2 GHz region and have characteristics particularly suitable for PCN base station applications.

Device	$P_{out}$ Watts	Class	Bias Point Vdc/mA	Gain (Typ)/Freq dB/MHz	$\theta_{JC}$ °C/W	Package/Style
MRF6401 <sup>(12)</sup> ★	0.5	A	20/80	10/1880	30	305C/1
MRF6402 <sup>(13)</sup> ★	4.5	AB	26/40	10/1880	5	319/2
MRF6404 <sup>(16)</sup> ★	30	AB	26/150	9/1880	1.4	395C/1

**Table 26. Microwave Linear Power**

Common emitter microwave devices are offered for a wide variety of uses in small and medium signal, Class A, AB and C applications up to 4 GHz. The use of all-gold metal systems, diffused ballast resistors and hermetic packaging results in devices that display excellent reliability even in a military environment.

Device	$G_{SS}$ (Min) @ Freq. Small Signal Gain dB/GHz	1 dB Comp. Watts	$P_{sat}$ Watts	-30 dB IMD Watts	Emitter Current mA	Package/Style
<b>VDD = 20 Volts</b>						
MRW52602	6/2	3.6	5	3	440	328A-03/1
MRW52604	5/2	7.2	10	6	880	328A-03/1
MRW53502	5/3	1.6	2	1.5	230	401/1
MRW53601	6/3	0.8	1	0.8	120	328A-03/1
MRW54001	5/4	0.5	0.8	0.5	120	400/1
MRW54601	6/4	0.5	0.8	0.5	120	328A-03/1

<sup>(8)</sup>Vision Carrier: -8 dB; Sound Carrier: -7 dB; Sideband Carrier: -16 dB

<sup>(11)</sup>Output power at 1 dB compression in Class AB

<sup>(12)</sup>Formerly known as "TP4001S"

<sup>(13)</sup>Formerly known as "TP4004"

<sup>(15)</sup>Formerly known as "TP4025"

<sup>(16)</sup>Formerly known as "TP4035"

★New Product

Devices listed in bold, italic are Motorola preferred devices.



## RF Small Signal Bipolar Transistors

Motorola's broad line of RF Small Signal Transistors includes NPN and PNP Silicon Bipolar Transistors characterized for low noise amplifiers, mixers, oscillators, multipliers, non-saturated switches and low-power drivers.

These devices are available in a wide variety of package types: plastic Macro-X and Macro-T, ceramic and surface mounted. Most of these transistors are fully characterized with s-parameters.



CASE 29-04  
STYLE 2  
(TO-226AA)

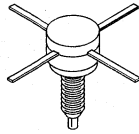

CASE 244A  
STYLE 1, 3



CASE 317  
STYLE 2  
(MACRO-X)



CASE 317A  
STYLE 2  
(MACRO-T)



CASE 317D  
STYLE 2, 3  
(POWER MACRO)

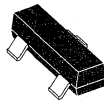

CASE 318-07  
STYLE 6  
(SOT-23)



CASE 318A  
STYLE 1  
LOW PROFILE  
(SOT-143)



CASE 419  
STYLE 3  
(SC-70/SOT-323)



CASE 751  
STYLE 1  
(SO-8)

5

# RF Small Signal Bipolar Transistors

## RF Small Signal Transistor Gain Characteristics

Curve numbers apply to transistors listed in the subsequent tables.

## Selection by Package

In small-signal RF applications, the package style is often determined by the end application or circuit construction technique. To aid the circuit designer in device selection, the Motorola broad range of RF small-signal amplifier transistors is organized by package. Devices for other applications such as oscillators or switches are shown in the appropriate preceding tables. **These devices are NPN polarity unless otherwise designated.**

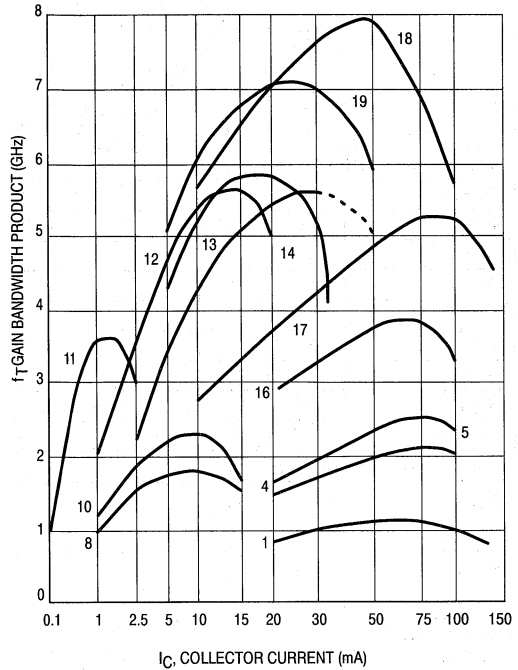

## Plastic SOE Case

Table 1. Plastic SOE Case

Device	Gain-Bandwidth		Curve No. Page 5.10-15	NF @ f		Gain @ f		Maximum Ratings			Package
	f <sub>T</sub> Typ GHz	I <sub>C</sub> mA		Typ dB	MHz	Typ dB	MHz	V <sub>(BR)CEO</sub> Volts	I <sub>C</sub> mA	P <sub>T</sub> mW	

### Case 29-04/2, TO-226AA

MPS536 <sup>(17)</sup>	5	-20	19	4.5	500	14	500	-10	-30	625	
LP1001	5	10	—	2.7	500	12.5	1000	15	—	625	
LP1001A	5	10	—	3.2	1000	12.5	1000	15	—	625	
LP1983	4.5	15	—	2.4	900	12	900	15	30	300	
MPS901 <sup>(29)</sup>	4.5	15	12	2.4	900	12	900	15	30	300	
MPS911 <sup>(29)</sup>	7	30	13	1.7	500	16.5	500	12	40	625	
MPS571 <sup>(29)</sup>	8	50	18	2	500	14	500	10	80	625	
MPS3866 <sup>(29)</sup>	0.8	50	1	—	—	10	400	30	400	625	

<sup>(17)</sup>PNP

<sup>(29)</sup>Packaging Options Available in Tape and Reel and Fan Fold Box

5

## Selection by Package (continued)

Table 1. Plastic SOE Case (continued)

Device	Gain-Bandwidth		Curve No. Page 5.10-15	NF @ f		Gain @ f		Maximum Ratings			Package
	@			Typ dB	MHz	Typ dB	MHz	$V_{(BR)CEO}$ Volts	$I_C$ mA	$P_T$ mW	
	$f_T$ Typ GHz	$I_C$ mA									

### Case 317/2 — MACRO-X

MRF521(17)	4.2	-50	—	2.8	1000	11	1000	-10	-70	750	
MRF901	4.5	15	12	2	1000	12	1000	15	30	375	
MRF941	8	15	—	2.1	2000	12.5	2000	10	50	400	
MRF951	7.5	30	—	2.1	2000	12.5	2000	10	100	1000	
MRF571	8	50	18	1.5	1000	12	1000	10	70	1000	
<b>MRF581</b>	5	75	17	2	500	15.5	500	18	200	2500	
MRF581A	5	75	17	1.8	500	15.5	500	15	200	2500	
MRF837	5	75	17	—	—	10	870	16	200	2500	
<b>MRF559</b>	3	100	16	—	—	13	512	18	150	2000	

### Case 317A/2 — MACRO-T

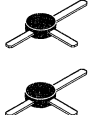
<b>BFR90</b>	5	14	12	2.4	500	18	500	15	30	180	
<b>BFR96</b>	4.5	50	14	2	500	14.5	500	15	100	500	

### Case 317D/2,3

MRF553	—	—	—	—	—	13	175	16	500	3000	
MRF555	—	—	—	—	—	12.5	470	16	400	3000	
<b>MRF557</b>	—	—	—	—	—	9	870	16	400	3000	

### Case 318-07/6 — SOT-23

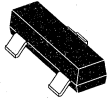
<b>MMBR521LT1(17)</b>	3.4	-35	—	1.5	500	15	500	-10	-70	312	
<b>MMBR536LT1(17)</b>	5.5	-20	19	4.5	500	14	500	-10	-30	350	
MMBR4957LT1(17)	1.2	-2	10	3	450	17	450	-30	-30	350	
<b>MMBR931LT1</b>	3	1	11	4.3	1000	10	1000	5	5	350	
<b>MMBR5031LT1</b>	1	5	—	2.5	450	17	450	10	20	350	
<b>MMBR5179LT1</b>	1.4	5	8	4.5	200	15	200	12	50	350	
<b>BFR92ALT1</b>	3.4	14	—	3.0	500	15	—	15	25	350	
<b>MMBR920LT1</b>	4.5	14	—	2.4	500	15	500	15	35	350	
<b>MMBR901LT1</b>	4	15	12	1.9	1000	12	1000	15	30	350	
<b>MMBR941LT1</b>	8	15	—	2.1	2000	8.5	2000	10	50	400	
MMBR941BLT1	8	15	—	2.1	2000	8.5	2000	10	50	400	
BFS17LT1	1.3	25	—	5	30	—	—	15	—	350	
BFR93ALT1	3.4	30	—	2.5	30	—	—	12	35	350	
MMBR911LT1	6	30	13	2	500	17	500	12	40	350	
<b>MMBR951LT1</b>	8	30	—	2.1	2000	7.5	2000	10	100	500	
MMBR951ALT1	8	30	—	2.1	2000	7.5	2000	10	100	500	
<b>MMBR571LT1</b>	8	50	18	2	500	16.5	500	10	80	350	

(17)PNP

Devices listed in bold, italic are Motorola preferred devices.

## Selection by Package (continued)

Table 1. Plastic SOE Case (continued)

Device	Gain-Bandwidth		Curve No. Page 5.10-15	N @ f		Gain @ f		Maximum Ratings			Package
	@			Typ dB	MHz	Typ dB	MHz	V <sub>(BR)</sub> CEO Volts	I <sub>C</sub> mA	P <sub>T</sub> mW	
	f <sub>T</sub> Typ GHz	I <sub>C</sub> mA									

### Case 318A/1 — SOT-143

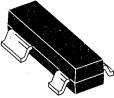
<b>MRF5211LT1</b> (17)	4.2	-50	—	2.8	1000	11	1000	-10	-70	580	
<b>MRF9331LT1</b>	5	1	—	2.5	1000	12.5	1000	8	1	50	
<b>MRF9011LT1</b>	3.8	15	12	2.3	1000	10.2	1000	15	30	300	
<b>MRF9411LT1</b>	8	15	—	2.1	2000	9.5	2000	10	50	400	
MRF9411BLT1	8	15	—	2.1	2000	9.5	2000	10	50	400	
<b>MRF9511LT1</b>	8	30	—	2.1	2000	9	2000	10	100	500	
MRF0211LT1	5.5	40	18	1.8	1000	9.5	1000	15	70	580	
<b>MRF5711LT1</b>	8	50	18	1.6	1000	13.5	1000	10	70	580	

### Case 419/3 — SC-70/SOT-323

MRF947T1	8	15	—	2.1	1500	10.5	1500	10	50	175	
MRF947BT1	8	15	—	2.1	1500	10.5	1500	10	50	175	
MRF957T1	8	30	—	2.0	1500	9	1500	10	100	175	

### Case 751/1 — SO-8

MRF5583(17)(18)	2.1	-35	5	—	—	1.5	250	-30	-500	1000	
<b>MRF5943</b> (18)	1.5	35	4	3.4	200	12	250	30	400	1000	
<b>MRF3866</b> (18)	0.8	50	1	—	—	10.5	400	30	400	1000	
MRF4427(18)	1.6	50	1	—	—	18	175	20	400	1000	
MRFQ17(18)	2.25	50	5	—	—	12	500	25	300	1000	
<b>MRF5812</b> (18)	5.5	75	17	2	500	15.5	500	15	200	1500	
<b>MRF8372</b> (18)	5	75	17	—	—	10	870	16	200	1500	

5

## Ceramic SOE Case

Table 2. Ceramic SOE Case

Device	Gain-Bandwidth		Curve No. Page 5.10-15	N @ f		Gain @ f		Maximum Ratings			Package
	@			Typ dB	MHz	Typ dB	MHz	V <sub>(BR)</sub> CEO Volts	I <sub>C</sub> mA	P <sub>T</sub> mW	
	f <sub>T</sub> Typ GHz	I <sub>C</sub> mA									

### Case 244A/1,3

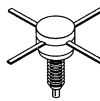
MRF587	5.5	90	17	3	500	13	500	15	200	5000	
--------	-----	----	----	---	-----	----	-----	----	-----	------	---

(17)PNP





(18)Tape and Reel Packaging Options Available

Devices listed in bold, italic are Motorola preferred devices.

# Selection by Application

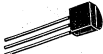
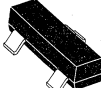
**Table 3. Low Noise**

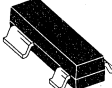
The Small-Signal devices listed are designed for low noise and high gain amplifier mixer, and multiplier applications. Each transistor type is available in various packages. **Polarity is NPN unless otherwise noted.**

Package	Name	Case Number	Curve Number (See figure below)					
			1	2(17)	3	4	5	6
	MACRO-X	317/2	MRF941 MRF951(20)	MRF521	MRF571	<b>MRF581</b>	MRF901	—
	TO-226AA	29-04/2	—	—	MPS571	—	MPS901	MPS911
	SOT-23	318-07/6	<b>MMBR941LT1</b> <b>MMBR951LT1(20)</b>	<b>MMBR521LT1</b>	<b>MMBR571LT1</b>	—	<b>MMBR901LT1</b>	MMBR911LT1
	SC-70/ SOT-323	419/3	MRF947T1 MRF947BT1 MRF957T1(20)	—	—	—	—	—
	SOT-143	318A/1	<b>MRF9411LT1</b> <b>MRF9511LT1(20)</b>	<b>MRF5211LT1</b>	<b>MRF5711LT1</b> MRF0211LT1(17)	—	<b>MRF9011LT1</b>	—
	SO-8	751/1	—	—	—	<b>MRF5812</b>	—	—

(17)PNP

(20)Higher Current Version

**5**

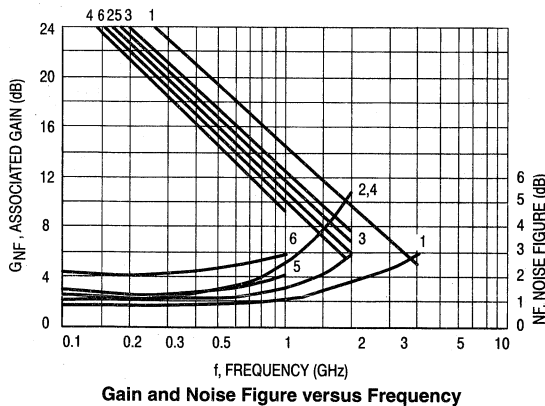

Devices listed in bold, italic are Motorola preferred devices.

## Selection by Application (continued)

**Table 4. CATV, MATV and Class A Linear**

For Class A linear CATV/MATV applications. Listed according to increasing gain bandwidth ( $f_T$ ).

Device	Nominal Test Conditions V <sub>CE</sub> /I <sub>C</sub> Volts/mA	f <sub>T</sub> Typ MHz	Noise Figure	Distortion Specifications				V <sub>(BR)CEO</sub> V	Package/ Style
			Typ/Freq. dB/MHz	2nd Order IMD dBc	3rd Order IMD dBc	12 Ch. Cross- Mod. dBc	Output Level dBmV		
<b>MMBR5179LT1</b>	6/5	1500	4/450					12	318-07/6
MRF5943	15/50	1500	3.4/200					30	751/1
MRF5583(17)	10/-100	1500						-30	751/1
MMBR4957LT1(17)	10/-2	2000	3/450					-30	318-07/6
MMBR5031LT1	6/5	2000	1.9/450					10	318-07/6
MRFQ17	12.5/50	2200						25	751/1
<b>MMBR920LT1</b>	10/14	4500	2.4/500					15	318-07/6
<b>BFR96</b>	10/50	4500	2/500					15	317A/2
<b>BFR90</b>	10/14	5000	2.4/500					15	317A/2
<b>MRF581</b>	10/75	5000	2.7/300		-65		+50	18	317/2
<b>MRF581A</b>	10/75	5000	1.8/500		-65		+50	15	317/2
<b>MRF5812</b>	10/75	5000	1.8/500		-65		+50	15	751/1
LP1001		5000	2.7/500					15	29-04/2
LP1001A		5000	3.2/1000					15	29-04/2
<b>MRF587</b>	15/90	5500	3/500	-52	-72		+50	17	244A/1

**Table 5. UHF and Microwave Oscillators**

The transistors listed below are for UHF and microwave oscillator applications as initial signal sources or as output stages of limited range transmitters. Devices are listed in order of increasing output power.

Device	Test Conditions		P <sub>out</sub> Min mW	f <sub>T</sub> Typ MHz	Package/Style
	f MHz	V <sub>CC</sub> Volts			
MPS3866	400	15	1000	800	29-04/2
MRF3866	400	15	1000	800	751/1

(17)PNP

5

Devices listed in bold, italic are Motorola preferred devices.

## RF Integrated Circuits

Motorola's RF integrated circuit devices provide an integrated solution for the personal communications market. These devices are available in plastic SOIC-8 or SOIC-16 packages.



CASE 751  
(SO-8)



CASE 751B  
(SO-16)

# RF Integrated Circuits

The MRFIC2001 thru MRFIC2006 device series is Motorola's first introduction of an integrated solution for the personal communications market. Although designed as a chip set solution for CT2, the partitioning of the functions makes the use of these devices ideal in other 900 MHz personal communications systems such as cordless telephone (915 MHz), GSM, and ISM designs.

## To 1.0 GHz

Device	RF Freq. Range MHz	IF Freq. Range MHz	Supply Volt. Range V	Supply Current mA (Typ)	Conv. Gain dB (Typ)	Output Level, 1 dB Comp. dBm (Typ)	Package
--------	--------------------	--------------------	----------------------	-------------------------	---------------------	------------------------------------	---------

**Table 1. Down Converter**

<b>MRFIC2001</b> ★(18)	500–1000	0–250	2.7–5.0	4.7	23	–10	751
------------------------	----------	-------	---------	-----	----	-----	-----

Device	RF Freq. Range MHz	IF Freq. Range MHz	Supply Volt. Range V	Supply Current mA (Typ)	Conv. Gain dB (Typ)	Output Level, 1 dB Comp. dBm (Typ)	Package
--------	--------------------	--------------------	----------------------	-------------------------	---------------------	------------------------------------	---------

**Table 2. Upmixer**

<b>MRFIC2002</b> ★(18)	500–1000	0–250	2.7–5.0	5.5	10	–18	751
<b>MRFIC2101</b> ★(18)	800–1000	0–250	4.75	45	26.5	4.5	751B

Device	Freq. Range MHz	Supply Volt. Range V	Supply Current $\mu$ A (Typ)	Recommended Input Power dBm	Insertion Loss Port RF1 to RF2 /RF1 to RF3 dB (Typ)	Isolation Port RF1 to RF2 /RF1 to RF3 dB (Typ)	Package
--------	-----------------	----------------------	------------------------------	-----------------------------	---	--	---------

**Table 3. Antenna Switch**

<b>MRFIC2003</b> ★(18)	100–1000	2.8–6.0	<10	17	0.8/0.5	23/20	751
------------------------	----------	---------	-----	----	---------	-------	-----

Device	Freq. Range MHz	Supply Volt. Range V	Supply Current TX/RX mA (Typ)	Small Signal Gain dB (Typ)	Gain Control dB (Typ)	P <sub>out</sub> , 1 dB Compression dBm (Typ)	Package
--------	-----------------	----------------------	-------------------------------	----------------------------	-----------------------	---	---------

**Table 4. Driver and Ramp**

<b>MRFIC2004</b> ★(18)	800–1000	2.7–4.0	11/0.7	21.5	34	–1	751B
------------------------	----------	---------	--------	------	----	----	------

Device	Freq. Range MHz	Supply Volt. Range V	Supply Current mA (Typ)	Small Signal Gain dB (Typ)	Return Loss Input/Output dB (Typ)	P <sub>out</sub> , 1 dB Compression dBm (Typ)	Package
--------	-----------------	----------------------	-------------------------	----------------------------	-----------------------------------	---	---------

**Table 5. Integrated Power Amplifier**

<b>MRFIC2006</b> ★(18)	500–1000	1.8–4.0	46	23	15	15.5	751
<b>MRFIC2101</b> ★(18)	800–1000	4.75	38	16	—	18	751B

(18)Tape and Reel Packaging Options Available

★New Product

5

Devices listed in bold, italic are Motorola preferred devices.



## To 1.8 GHz

Designed specifically for DECT and JPHP, the MRFIC1801 through MRFIC1804 device series offers complete transmit and receive functions, less Lo and filters, for a typical 1.8 GHz cordless telephone. This chip set is also applicable in other 1.9 GHz and 2.4 GHz personal communications systems.

Device	Operating Freq. Range GHz	Supply Volt. Range V	Supply Current TX Mode $\mu$ A (Typ)	Leakage Current $\mu$ A (Typ)	Insertion Loss TX Mode dB (Typ)	P <sub>in</sub> , 1 dB Compression dBm (Typ)	Package
--------	---------------------------	----------------------	--------------------------------------	-------------------------------	---------------------------------	--	---------

**Table 6. Antenna Switch**

<b>MRFIC1801</b> ★ <sup>(18)</sup>	1.5–2.5	2.7–5.5	300	45	0.6	29	751
------------------------------------	---------	---------	-----	----	-----	----	-----

Device	RF Output Freq. Range GHz	Supply Volt. Range V	Supply Current TX Mode mA (Typ)	Conversion Gain dB (Typ)	Recommended IF Input MHz (Typ)	P <sub>out</sub> , 1 dB Compression dBm (Typ)	Package
--------	---------------------------	----------------------	---------------------------------	--------------------------	--------------------------------	---	---------

**Table 7. Upconverter**

<b>MRFIC1803</b> ★ <sup>(18)</sup>	1.7–2.0	2.7–3.3	28	10	70–325	–2	751B
------------------------------------	---------	---------	----	----	--------	----	------

Device	IF Output Freq. Range MHz	Supply Volt. Range V	Supply Current RX Mode mA (Typ)	Mixer Conv. Gain dB (Typ)	LNA Gain dB (Typ)	LNA Noise Fig. dB (Typ)	Package
--------	---------------------------	----------------------	---------------------------------	---------------------------	-------------------	-------------------------	---------

**Table 8. Amplifier and Downmixer**

<b>MRFIC1804</b> ★ <sup>(18)</sup>	70–325	2.7–3.3	7	4	15.5	2.3	751B
------------------------------------	--------	---------	---	---	------	-----	------

<sup>(18)</sup>Tape and Reel Packaging Options Available

★New Product

5

Devices listed in bold, italic are Motorola preferred devices.

# RF Amplifiers

Motorola's line of RF amplifiers designed and specified for use in land mobile radios, CATV distribution systems and general purpose wideband amplification applications. They feature small size, matched inputs and outputs, high stability and guaranteed performance specifications. For the user they offer the benefits of smaller and less complex system designs, in less time and at lower overall cost.

Each amplifier uses modern transistor chips which are gold metallized and have silicon nitride passivation for increased reliability and long life. Chip and wire construction features MOS capacitors and laser trimmed nichrome resistors. Circuit substrates and metallization have been selected for optimum performance cost and reliability.

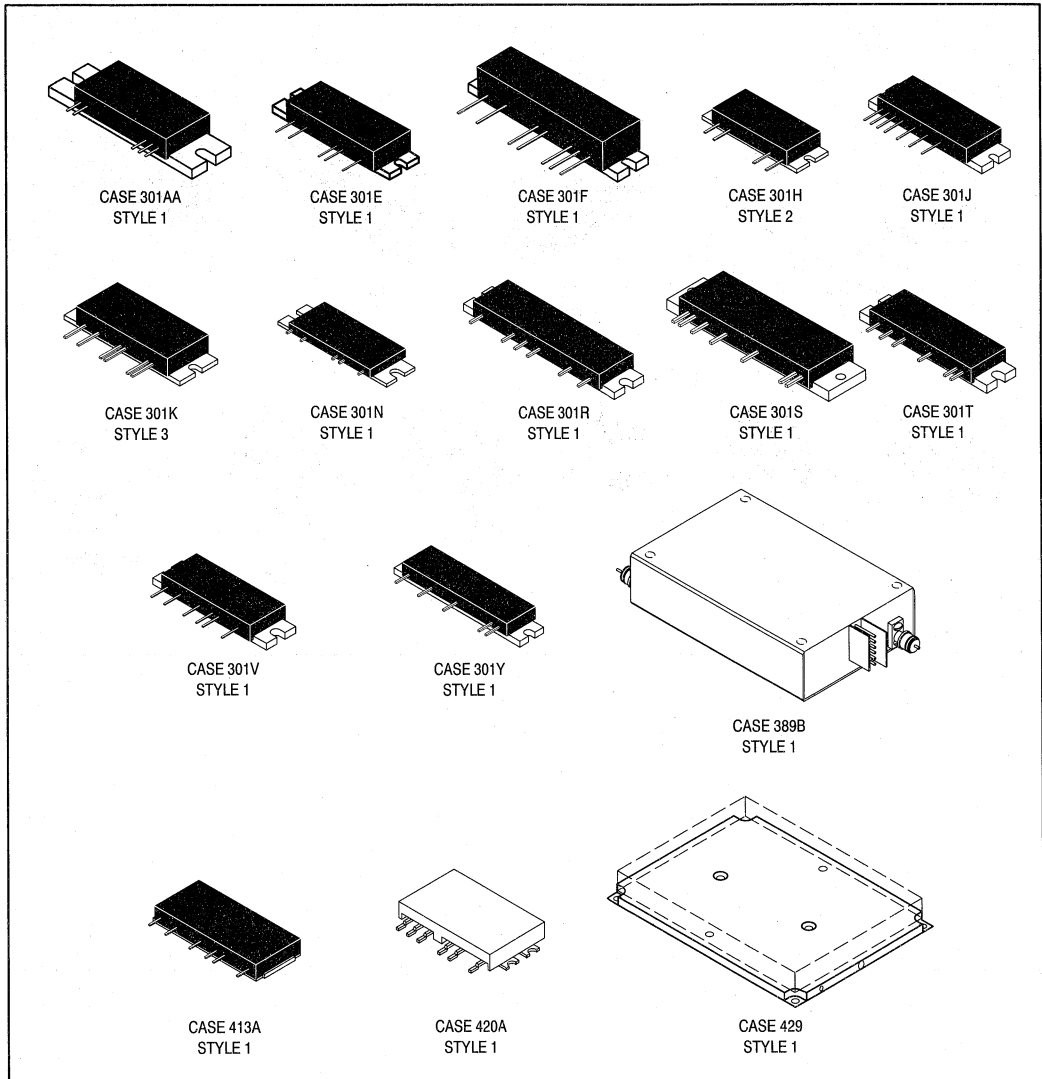

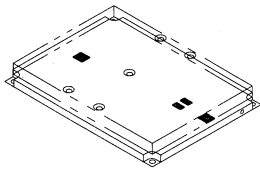

CASE429A  
STYLE 1

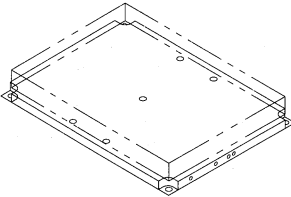

CASE 429C  
STYLE 1

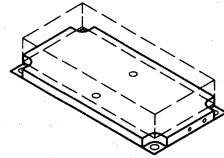

CASE 429E  
STYLE 1

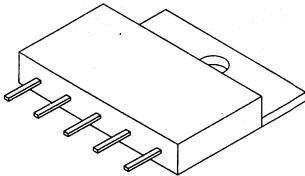

CASE 431A  
STYLE 1

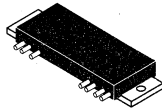

CASE 700  
STYLE 1

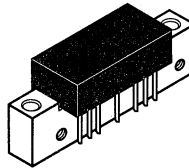

CASE 714  
STYLE 1

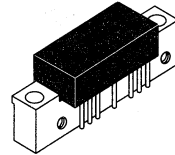

CASE 714F  
STYLE 1

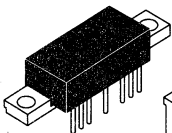

CASE 714G  
STYLE 1

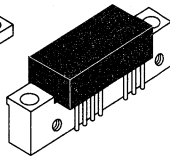

CASE 714H  
STYLE 1

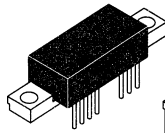

CASE 714L  
STYLE 1

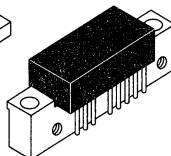

CASE 714M  
STYLE 1

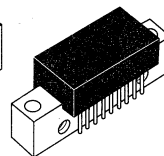

CASE 714P  
STYLE 2, 3

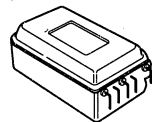

CASE 825A  
STYLE 1

5

# RF Amplifiers

## High Power

Complete amplifiers with 50 ohm in/out impedances are available for a variety of applications including land mobile radios, base stations, TV transmitters and other uses requiring large-signal amplification, both linear and Class C. Frequencies covered range from 68–950 MHz with power levels extending to 180 watts.

### Land Mobile/Portable

The advantages of small size, reproducibility and overall lower cost become more pronounced with increasing frequency of operation. These amplifiers offer a wide range in power levels and gain, with guaranteed performance specifications for bandwidth, stability and ruggedness.

Table 1. VHF/UHF, Class C

Device	P <sub>out</sub> Output Power Watts	P <sub>in</sub> Input Power Watts	f Frequency MHz	G <sub>p</sub> Power Gain, Min dB	V <sub>CC</sub> Supply Voltage Volts	Package/Style
<b>68–210 MHz, VHF Band — Class C (Silicon Bipolar Die)</b>						
<i>MHW105</i>	5	0.001	68–88	37	7.5	301K/3
<i>MHW607-1</i>	7	0.001	136–150	38.4	7.5	301K/3
<i>MHW607-2</i>	7	0.001	146–174	38.4	7.5	301K/3
<i>MHW607-3</i>	7	0.001	174–195	38.4	7.5	301K/3
<i>MHW607-4</i>	7	0.001	184–210	38.4	7.5	301K/3
<b>400–512 MHz, UHF Band — Class C (Silicon Bipolar Die)</b>						
MHW704-1	3	0.001	400–440	34.8	7.5	301J/1
MHW704-2	3	0.001	440–470	34.8	7.5	301J/1
MHW707-1	7	0.001	403–440	38.4	7.5	301J/1
MHW707-2	7	0.001	440–470	38.4	7.5	301J/1
MHW707-3	7	0.001	470–500	38.4	7.5	301J/1
MHW707-4	7(23)	0.001	490–512	38.4(23)	7.5	301J/1
MHW720A1(22)	20	0.15	400–440	21	12.5	700/1
MHW720A2(22)	20	0.15	440–470	21	12.5	700/1
MHW720A3	20	0.15	450–458	21	12.5	700/1
<b>806–960 MHz, UHF Band — Class C (Silicon Bipolar Die)</b>						
<i>MHW851-1</i>	1.6	0.001	820–850	32	6	301N/1
<i>MHW851-2</i>	1.6	0.001	870–905	32	6	301N/1
<i>MHW851-3</i>	2	0.001	890–915	33	6	301N/1
<i>MHW851-4</i>	1.6	0.001	915–925	32	6	301N/1
MHW803-1	2	0.001	820–850	33	7.5	301E/1
MHW803-2	2	0.001	806–870	33	7.5	301E/1
MHW803-3	2	0.001	870–905	33	7.5	301E/1
MHW804-1	4	0.001	800–870	36	7.5	301F/1
MHW804-2	4	0.001	896–940	36	7.5	301F/1
MHW806A1(22)	6	0.03	820–850	23	12.5	301H/2
MHW806A2(22)	6	0.03	806–870	23	12.5	301H/2
MHW806A3(22)	6	0.04	890–915	21.7	12.5	301H/2
MHW806A4(22)	6	0.04	870–950	21.7	12.5	301H/2
MHW812A3(22)	12	0.1	890–915	20.8	13	301H/2
<b>806 – 960 MHz, UHF Band — Class C (G<sub>A</sub>A<sub>3</sub> FET Die)</b>						
<i>MHW9002-1(22)</i>	1.4	0.005	824–849	24.5	5.8	420A/1
<i>MHW9002-2(22)</i>	1.4	0.005	870–905	24.5	5.8	420A/1
<i>MHW9002-3(22)</i>	1.6	0.005	890–915	25	5.8	420A/1
<i>MHW9002-4(22)</i>	1.4	0.005	898–925	24.5	5.8	420A/1

(22) Designed for Wide Range P<sub>out</sub> Level Control

(23) P<sub>o</sub> @ f = 490 MHz. P<sub>o</sub> = 6.5 W @ f = 512 MHz

Devices listed in bold, italic are Motorola preferred devices.

## High Power: Land Mobile/Portable (continued)

Table 2. UHF, Linear

Device	P <sub>out</sub> Output Power Watts	P <sub>in</sub> Input Power Watts	f Frequency MHz	G <sub>p</sub> Power Gain, Min dB	V <sub>CC</sub> Supply Voltage Volts	Package/Style
<b>806–960 MHz, UHF Band — Class AB (Silicon Bipolar Die)</b>						
<b>MHW927A(22)</b>	6 <sup>(24)</sup>	0.001	824–849	37.8	12.5	301AA/1
MHW927B(22)	6 <sup>(24)</sup>	0.001	824–849	37.8	12.5	301AA/1
<b>880–915 MHz (for GSM) — Class AB (Silicon Bipolar Die)</b>						
MHW903(22)	3.5	0.001	890–915	35.4	7.2	413A/1
<b>MHW953(22)</b>	3.5	0.001	890–915	35.4	7.2	301V/1
MHW954(22)	3.5	0.1	890–915	15.4	7.2	301Y/1
MHW909(22)	9	0.1	890–915	19.5	7.2	301T/1
<b>MHW912(22)</b>	12	0.001	890–915	40.8	12.5	301R/1
<b>MHW914(22)</b>	14	0.001	890–915	41.4	12.5	301R/1
MHW915(22)	14	0.1	890–915	21.4	12.5	301T/1
MHW932(22)	32	0.1	890–915	26	12.5	301S/1

## TV Transmitters

Table 3. UHF Ultra Linear for TV Applications

These amplifiers are characterized for ultra-linear applications in Band IV and Band V TV transmitters.

Device	Frequency MHz	P <sub>ref</sub> Watts	G <sub>p</sub> (Min)/Freq. Power Gain dB/MHz	3 Tone <sup>(8)</sup> IMD 1 dB	3 Tone <sup>(25)</sup> IMD 2 dB	V <sub>CC</sub> Volts	Package/Style
<b>ATV6031</b>	470–860	20	10.5/860	–50	–53	26.5	389B/1
MRFA2600 <sup>(26)</sup> ★	470–860	20	10.5/860	–50	–53	26.5	429A/1
ATV6060	470–860	40	9/860	–50	–53	25.5	389U/1
MRFA2602 <sup>(28)</sup> ★	470–860	40	9/860	–50	–53	25.5	429C/1
RFA8090B★	470–860	95 <sup>(11)</sup>	8/860	—	—	28	429E/1
RFA8180B★	470–860	180 <sup>(11)</sup>	8/860	—	—	28	429/1

<sup>(8)</sup>Vision Carrier: – 8 dB; Sound Carrier: – 7 dB; Sideband Carrier: – 16 dB

<sup>(11)</sup>Output power at 1 dB compression in Class AB

<sup>(22)</sup>Designed for Wide Range P<sub>out</sub> Level Control

<sup>(24)</sup>Average Power; Peak Power is twice average power

<sup>(25)</sup>Vision Carrier: – 8 dB; Sound Carrier: – 10 dB; Sideband Carrier: – 16 dB

<sup>(26)</sup>Formerly known as "RFA6031"

<sup>(28)</sup>Formerly known as "RFA6060"

★New Product

Devices listed in bold, italic are Motorola preferred devices.

## Low Power

The following categories describe a wide range of complete amplifier assemblies both hybrid and monolithic for use in CATV distribution systems, instrumentation, communications and military equipment. A variety of power levels and frequencies of operation is offered for many applications.

### CATV Distribution

Motorola Hybrids are manufactured using fourth generation technology which has set new standards for CATV system performance and reliability. These hybrids have been optimized to provide premium performance in all CATV systems up to 152 channels.

Table 4. 5–200 MHz Hybrids

Device	Hybrid Gain (Nominal) dB	Channel Loading Capacity	Maximum Distortion Specifications						Noise Figure @ 175 MHz dB	Package/Style
			Output Level dBmV	2nd Order Test <sup>(30)</sup> dB	Composite Triple Beat dB		Cross Modulation dB			
					22 CH	26 CH	22 CH	26 CH		
<i>MHW1134</i>	13	22	+50	-72	-73	-71(19)	-65	-65(19)	7	714/1
<i>MHW1224</i>	22	22	+50	-72	-71	-68(19)	-62	-62(19)	5.5	714/1
<i>MHW1244</i>	24	22	+50	-72	-70	-68(19)	-61	-61(19)	5	714/1

Table 5. 40–450 MHz Hybrids

Device	Hybrid Gain (Nominal) dB	Channel Loading Capacity	Maximum Distortion Specifications				Noise Figure @ 450 MHz dB	Package/Style
			Output Level dBmV	2nd Order Test dB	Composite Triple Beat dB	Cross Modulation dB		
					60 CH	60 CH	Typ	

#### Conventional Hybrids

<i>MHW5122A</i>	12	60	+46	-72(31)	-58	-61	7	714/1
<i>MHW5142A</i>	14	60	+46	-74(31)	-61	-62	6	714/1
<i>MHW5172A</i>	17	60	+46	-74(31)	-60	-62	6	714/1
<i>MHW5182A</i>	18	60	+46	-72(31)	-61	-59	5.5	714/1
<i>MHW5183</i>	18	60	+46	-62(31)(32)	-58	-57	4.5	714/1
<i>MHW5222A</i>	22	60	+46	-72(31)	-60	-59	4.5	714/1
<i>MHW5272A</i>	27	60	+46	-72(31)	-59	-60	5.5	714/1
<i>MHW5342A</i>	34	60	+46	-72(31)	-59	-59	5	714/1
<i>MHW5382A</i>	38	60	+46	-70(31)	-59	-59	4	714/1
CA97901	21.2(44)	30	+46	-65	-65	-65	5.5	714F/1

#### Power Doubling Hybrids

<i>MHW5185B</i> ★	18	60	+46	-67(32)	-67	-67	5.5	714/1
<i>MHW5205</i>	20	60	+46	-58(33)	-64	-64	5.5	714/1
<i>MHW5225</i>	22	60	+46	-69(31)	-62	-60	5	714/1

#### Feedforward Hybrids

<i>MFF124B</i>	24	60	+46	-84(31)	-79	-75	10(34)	825A/1
----------------	----	----	-----	---------	-----	-----	--------	--------

(19)Typical

(30)Channels 2 and A @ 7

(31)Channels 2 and M13 @ M22

(32)Composite 2nd order;  $V_{out} = +46$  dBmV/ch

(33)Composite 2nd order IMD, 60 channel flat

(34)Maximum

(44)Hi-Slope Trunk Amplifier. The specified gain is at 450 MHz.

★New Product

Devices listed in bold, italic are Motorola preferred devices.

## Low Power: CATV Distribution (continued)

Table 6. 40–550 MHz Hybrids

Device	Hybrid Gain (Nom.) dB	Channel Loading Capacity	Maximum Distortion Specifications						Noise Figure @ 550 MHz dB Typ	Package/Style
			Output Level dBmV	2nd Order Test dB	Composite Triple Beat dB		Cross Modulation dB			
					77 CH	87 CH	77 CH	87 CH		

### Conventional Hybrids

<i>MHW6122</i>	12	77	+44	-74(35)	-56	—	-62	—	7	714/1
<i>MHW6142</i>	14	77	+44	-72(35)	-59	—	-62	—	6.5	714/1
<i>MHW6172</i>	17	77	+44	-70(35)	-59	—	-62	—	6	714/1
<i>MHW6182</i>	18	77	+44	-72(35)	-58	—	-62	—	6	714/1
<i>MHW6183</i>	18	77	+44	-58(36)	-58	—	-58	—	5	714/1
<i>MHW6222</i>	22	77	+44	-66(35)	-57	—	-57	—	5	714/1
<i>MHW6272</i>	27	77	+44	-64(35)	-57	—	-57	—	6	714/1
<i>MHW6342</i>	34	77	+44	-64(35)	-57	—	-57	—	5.5	714/1

### Power Doubling Hybrids

<i>MHW6185B</i> ★	18	77	+44	-65(36)	-65	—	-68	—	6	714/1
<i>MHW6205</i> ★	20	77	+44	-60(36)	-64	—	-67	—	7.5	714/1
<i>MHW6225</i> ★	22	77	+44	-55(36)	-62	—	-63	—	7.0	714/1

### Feedforward Hybrids

<i>MFF224B</i>	24	77	+44	-86(35)	-75	—	-70	—	11(34)	825A/1
----------------	----	----	-----	---------	-----	---	-----	---	--------	--------

Table 7. 40–600 MHz Hybrids

Device	Hybrid Gain (Nom.) dB	Channel Loading Capacity	Maximum Distortion Specifications						Noise Figure @ 600 MHz dB Typ	Package/Style
			Output Level dBmV	2nd Order Test dB	Composite Triple Beat dB		Cross Modulation dB			
					85 CH	87 CH	85 CH	87 CH		

### Conventional Hybrids

<i>MHW6182-6</i>	18	87	+44	-56(36)	—	-57	—	-55	6	714/1
<i>MHW6222-6</i>	22	87	+44	-56(36)	—	-56	—	-56	6	714/1

### Power Doubling Hybrids

<i>MHW6185-6</i> ★	18	87	+44	-60(36)	—	-62	—	-66	5(34)	714/1
--------------------	----	----	-----	---------	---	-----	---	-----	-------	-------

### Feedforward Hybrids

<i>MFF324B</i>	24	85	+44	-86(38)	-73	—	-68	—	12.5	825A/1
----------------	----	----	-----	---------	-----	---	-----	---	------	--------

(34)Maximum

(35)Channels 2 and M30 @ M39

(36)Composite 2nd order;  $V_{out} = +44$  dBmV/ch

(37)600 MHz versions of the Conventional and Power Doubling Hybrids are available upon request. Please consult factory.

(38)Channels 2 and M39 @ M48

★New Product

Devices listed in bold, italic are Motorola preferred devices.

## Low Power: CATV Distribution (continued)

**Table 8. 40–860 MHz Hybrids**

Device	Hybrid Gain (Nom.) dB	Channel Loading Capacity	Maximum Distortion Specifications						Noise Figure Typ		Package/Style
			Output Level dBmV	2nd Order Test dB	Composite Triple Beat dB		Cross Modulation dB		dB		
					110 CH	128 CH	110 CH	128 CH	@ 750 MHz	@ 860 MHz	
<b>MHW7182★</b>	18	110	+44	-62(39)	-62	—	-64	—	5.5	—	714/1
<b>MHW7222★</b>	22	110	+40	-55(39)	-60	—	-60	—	5.5	—	714/1
<b>MHW8222★</b>	22	128	+38	-56(40)	—	-60	—	-60	—	6.4	714/1

**Conventional Hybrids**

**Table 9. 40–860 MHz Hybrids**

Device	Gain dB Typ	Frequency MHz	VCC Volts	2nd Order IMD @ V <sub>out</sub> = 50 dBmV/ch Max	DIN45004B @ f=860 MHz dB <sub>μ</sub> V Min	Noise Figure @ 860 MHz dB Max	Package/Style
<b>CA901</b>	17	40 – 860	24	-60	120	8	714P/2
<b>CA901A</b>	17	40 – 860	24	-64	120	8	714P/2
<b>CA902</b>	17	40 – 860	28	-63	123	9.5	714P/2
<b>CA902A</b>	17	40 – 860	28	-67	123	9.5	714P/2
<b>CA922</b>	17	40 – 860	24	-63	123	9.5	714P/2
<b>CA922A</b>	17	40 – 860	24	-67	123	9.5	714P/2
<b>CA912</b>	17	40 – 860	15	-63	123	9.5	714P/3
<b>CA912A</b>	17	40 – 860	15	-67	123	9.5	714P/3

**Power Doubling Hybrids**

**Table 10. 40–860/1000 MHz Hybrids**

Device	Hybrid Gain (Nom.) dB	Channel Loading Capacity	Maximum Distortion Specifications						Noise Figure @ 860 MHz dB	Package/Style
			Output Level dBmV	2nd Order Test dB	Cross Modulation dB		Composite Triple Beat dB			
					128 CH	152 CH	128 CH	152 CH	Typ	
<b>MHW8182★</b>	18	128	+38	-60(40)	-60	—	-60	—	6	714/1
<b>MHW9182★</b>	18	152	+38	-59(40)	—	-59	—	-59	6.5	714/1

(39)Composite 2nd order; V<sub>out</sub> = +40 dBmV/ch

(40)Composite 2nd Order; V<sub>out</sub> = +38 dBmV/ch

★New Product

Devices listed in bold, italic are Motorola preferred devices.



## Low Power: CATV Distribution (continued)

**Table 11. Standard Linear Hybrids**

The CA series of RF linear hybrid amplifiers consists of a family of medium power, broadband gain blocks in the CATV industry standard "CA" package. These amplifiers were designed for multi-purpose RF applications where linearity, dynamic range and wide bandwidth are of primary concern. Each amplifier is available in various package options. Eleven parts are available as indicated in a low profile package. Arrangement within the group is in order of increasing maximum frequency.

Device	BW MHz	Gain Flatness Typ ±dB	Gain/Freq. Typ dB/MHz	P <sub>1dB</sub> Typ dBm	NF/Freq. Typ dB/MHz	3rd Order Intercept Point/Freq. Typ dBm/MHz	VSWR Max 50 Ω/75Ω	V <sub>s</sub> /I <sub>s</sub> Typ V/mA	Case/ Style
<i>CA2830C</i>	5–200	0.5	34.5/100	29	4.7/200	46/200	2/—	24/300	714F/1
<i>CA2832C</i>	1–200	0.5	35.5/100	33	5/200	47/200	2/—	28/435	714F/1
<i>CA2833C</i>	5–200	0.5	34.5/100	29	4.7/200	46/200	2/—	24/300	714G/1
<i>CA2842C</i>	10–400	0.5	22/100	32	4/100	44/300	1.5/—	24/230	714F/1
<i>CA2810C</i>	10–450	1.5	34/50	30	—/300	43/300	2/1.3	24/310	714F/1
<i>CA2818C</i>	10–400	0.5	18.5/50	30	5/200	45/200	2/—	24/205	714F/1
<i>CA4800C</i> (41)	10–1000	1	17.5/1000	26	7.5/1000	38/1000	2.6/—	24/220	714P/2
<i>CA4812C</i> (41)	10–1000	1	17.5/1000	26	7.5/1000	38/1000	2.6/—	12/380	714P/3
<i>CA4815C</i> (41)	10–1000	1	17.5/1000	26	7.5/1000	38/1000	2.6/—	15/380	714P/3
<i>CA5800C</i> (41)	10–1000	1	15.5/1000	30	8.5/1000	40.5/1000	2.6/—	28/400	714P/2
<i>CA5801</i> (41)	50–1000	1	17.5/1000	30	8.5/1000	41.5/1000	2.6/—	28/400	714P/2
<i>CA5815C</i> (41)	10–1000	1	15.5/1000	30	8.5/1000	40.5/1000	2.6/—	15/700	714P/3

(41) Available in thin flange package (714T) by adding suffix "S" after part number, i.e., CA4800CS.

## CRT Drivers

5

**Table 12. Video Amplifiers**

These complete hybrid amplifiers are specifically designed for CRT driver applications requiring high frequency response and high voltage, such as high resolution color graphics video monitors. Gold metallized die and substrates are used to insure high reliability and improved ruggedness.

Device	V <sub>CC</sub> (nom) Volts	Gain(42) V/V	t <sub>r</sub> /t <sub>f</sub> (Typ)(43) nsec	3 dB BW (Typ)(43) MHz	V <sub>out</sub> (Max) Volts	Load	Package/Style
<i>CR2428</i> ★	60	12	2.0	145	50 P–P	6 to 20 pF	431A/1
<i>CR3428</i> ★	80	12	2.2	130	70 P–P	6 to 20 pF	431A/1

(42) Insertion Gain; 50 Ohm Source

(43) Capacitive Load 8.5 pF, V<sub>out</sub> = 40 V P–P

★ New Product

Devices listed in bold, italic are Motorola preferred devices.

# Surface Mount Information

---

## In Brief . . .

Surface Mount Technology is now being utilized to offer answers to many problems that have been created in the use of insertion technology.

Limitations have been reached with insertion packages and PC board technology. Surface Mount Technology offers the opportunity to continue to advance the state-of-the-art designs that cannot be accomplished with Insertion Technology.

Surface Mount Packages allow more optimum device performance with the smaller Surface Mount configuration. Internal lead lengths, parasitic capacitance and inductance that placed limitations on chip performance have been reduced.

The lower profile of Surface Mount Packages allows more boards to be utilized in a given amount of space. They are stacked closer together and utilize less total volume than insertion populated PC boards.

Printed circuit costs are lowered with the reduction of the number of board layers required. The elimination or reduction of the number of plated through holes in the board contribute significantly to lower PC board prices.

Surface Mount assembly does not require the preparation of components that is common on insertion technology lines. Surface Mount components are sent directly to the assembly line, eliminating an intermediate step.

Automatic placement equipment is available that can place Surface Mount components at the rate of a few thousand per hour to hundreds of thousands of components per hour.

Surface Mount Technology is cost effective, allowing the manufacturer the opportunity to produce smaller units and offer increased functions with the same size product.

	<b>Page</b>
Information for Using Surface Mount Packages . . . .	5.11-2
Footprints for Soldering . . . . .	5.11-5

## INFORMATION FOR USING SURFACE MOUNT PACKAGES

### RECOMMENDED FOOTPRINTS FOR SURFACE MOUNTED APPLICATIONS

Surface mount board layout is a critical portion of the total design. The footprint for the semiconductor packages must be the correct size to ensure proper solder connection interface between the board and the package. With the correct pad

geometry, the packages will self align when subjected to a solder reflow process.

### POWER DISSIPATION FOR A SURFACE MOUNT DEVICE

The power dissipation for a surface mount device is a function of the drain/collector pad size. These can vary from the minimum pad size for soldering to a pad size given for maximum power dissipation. Power dissipation for a surface mount device is determined by  $T_{J(max)}$ , the maximum rated junction temperature of the die,  $R_{\theta JA}$ , the thermal resistance from the device junction to ambient, and the operating temperature,  $T_A$ . Using the values provided on the data sheet,  $P_D$  can be calculated as follows:

$$P_D = \frac{T_{J(max)} - T_A}{R_{\theta JA}}$$

The values for the equation are found in the maximum ratings table on the data sheet. Substituting these values into the equation for an ambient temperature  $T_A$  of 25°C, one can calculate the power dissipation of the device. For example, for a SOT-223 device,  $P_D$  is calculated as follows.

$$P_D = \frac{150^\circ\text{C} - 25^\circ\text{C}}{156^\circ\text{C/W}} = 800 \text{ milliwatts}$$

The 156°C/W for the SOT-223 package assumes the use of the recommended footprint on a glass epoxy printed circuit board to achieve a power dissipation of 800 milliwatts. There are other alternatives to achieving higher power dissipation from the surface mount packages. One is to increase the area of the drain/collector pad. By increasing the area of the drain/collector pad, the power dissipation can be increased. Although the power dissipation can almost be doubled with this method, area is taken up on the printed circuit board which can defeat the purpose of using surface mount technology. For example, a graph of  $R_{\theta JA}$  versus drain pad area is shown in Figures 1, 2 and 3.

Another alternative would be to use a ceramic substrate or an aluminum core board such as Thermal Clad™. Using a board material such as Thermal Clad, an aluminum core board, the power dissipation can be doubled using the same footprint.

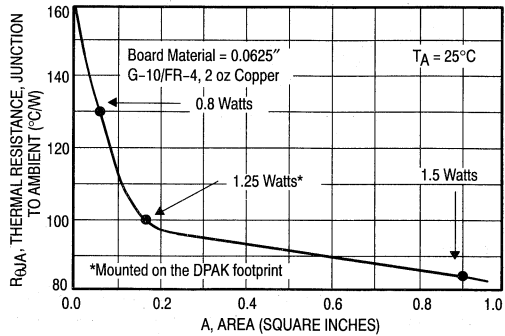

Figure 1. Thermal Resistance versus Drain Pad Area for the SOT-223 Package (Typical)

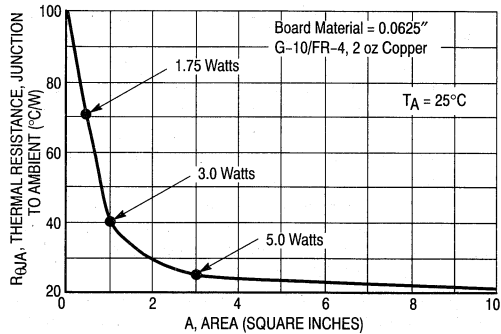

Figure 2. Thermal Resistance versus Drain Pad Area for the DPAK Package (Typical)

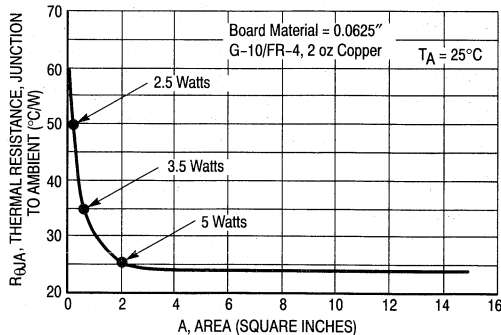

Figure 3. Thermal Resistance versus Drain Pad Area for the D2PAK Package (Typical)

5

## SOLDER STENCIL GUIDELINES

Prior to placing surface mount components onto a printed circuit board, solder paste must be applied to the pads. Solder stencils are used to screen the optimum amount. These stencils are typically 0.008 inches thick and may be made of brass or stainless steel. For packages such as the SC-59, SC-70/SOT-323, SOD-123, SOT-23, SOT-143, SOT-223, SO-8, SO-14, SO-16, and SMB/SMC diode packages, the stencil opening should be the same as the pad size or a 1:1 registration. This is not the case with the DPAK and D<sup>2</sup>PAK packages. If a 1:1 opening is used to screen solder onto the drain pad, misalignment and/or "tombstoning" may occur due to an excess of solder. For these two packages, the opening in the stencil for the paste should be approximately 50% of the tab area. The opening for the leads is still a 1:1 registration. Figure 4 shows a typical stencil for the DPAK and D<sup>2</sup>PAK packages. The pattern of the opening in the stencil for the

drain pad is not critical as long as it allows approximately 50% of the pad to be covered with paste.

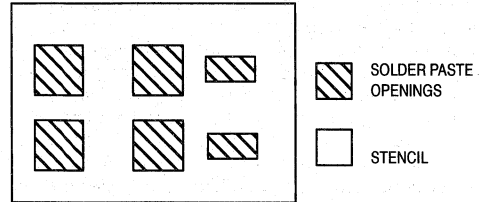

Figure 4. Typical Stencil for DPAK and D<sup>2</sup>PAK Packages

## SOLDERING PRECAUTIONS

The melting temperature of solder is higher than the rated temperature of the device. When the entire device is heated to a high temperature, failure to complete soldering within a short time could result in device failure. Therefore, the following items should always be observed in order to minimize the thermal stress to which the devices are subjected.

- Always preheat the device.
- The delta temperature between the preheat and soldering should be 100°C or less.\*
- When preheating and soldering, the temperature of the leads and the case must not exceed the maximum temperature ratings as shown on the data sheet. When using infrared heating with the reflow soldering method, the difference should be a maximum of 10°C.
- The soldering temperature and time should not exceed 260°C for more than 10 seconds.
- When shifting from preheating to soldering, the maximum temperature gradient shall be 5°C or less.

- After soldering has been completed, the device should be allowed to cool naturally for at least three minutes. Gradual cooling should be used since the use of forced cooling will increase the temperature gradient and will result in latent failure due to mechanical stress.
- Mechanical stress or shock should not be applied during cooling.

\* Soldering a device without preheating can cause excessive thermal shock and stress which can result in damage to the device.

\* Due to shadowing and the inability to set the wave height to incorporate other surface mount components, the D<sup>2</sup>PAK is not recommended for wave soldering.

5

## TYPICAL SOLDER HEATING PROFILE

For any given circuit board, there will be a group of control settings that will give the desired heat pattern. The operator must set temperatures for several heating zones and a figure for belt speed. Taken together, these control settings make up a heating "profile" for that particular circuit board. On machines controlled by a computer, the computer remembers these profiles from one operating session to the next. Figure 5 shows a typical heating profile for use when soldering a surface mount device to a printed circuit board. This profile will vary among soldering systems, but it is a good starting point. Factors that can affect the profile include the type of soldering system in use, density and types of components on the board, type of solder used, and the type of board or substrate material being used. This profile shows temperature versus time. The line on the graph shows the actual temperature that might be

experienced on the surface of a test board at or near a central solder joint. The two profiles are based on a high density and a low density board. The Vitronics SMD310 convection/infrared reflow soldering system was used to generate this profile. The type of solder used was 62/36/2 Tin Lead Silver with a melting point between 177–189°C. When this type of furnace is used for solder reflow work, the circuit boards and solder joints tend to heat first. The components on the board are then heated by conduction. The circuit board, because it has a large surface area, absorbs the thermal energy more efficiently, then distributes this energy to the components. Because of this effect, the main body of a component may be up to 30 degrees cooler than the adjacent solder joints.

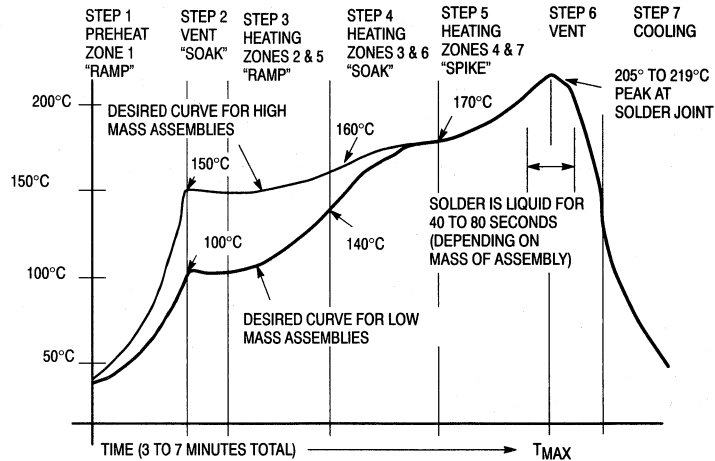
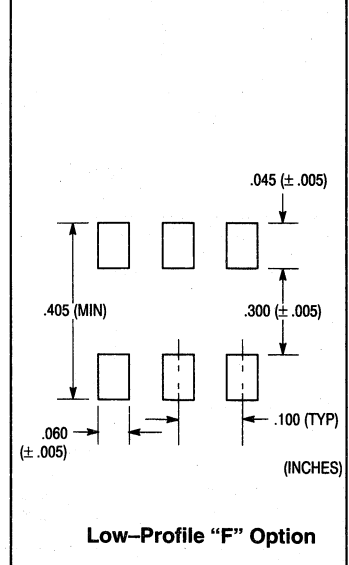
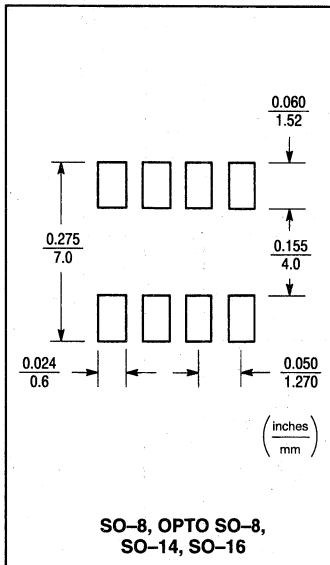
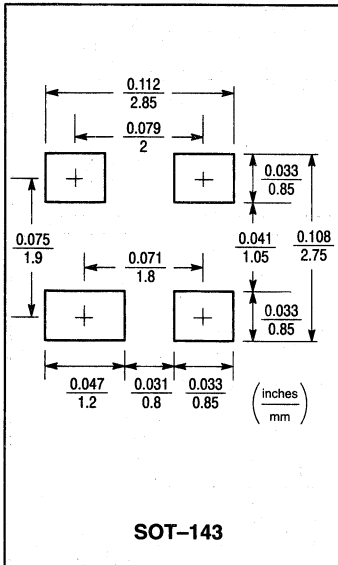
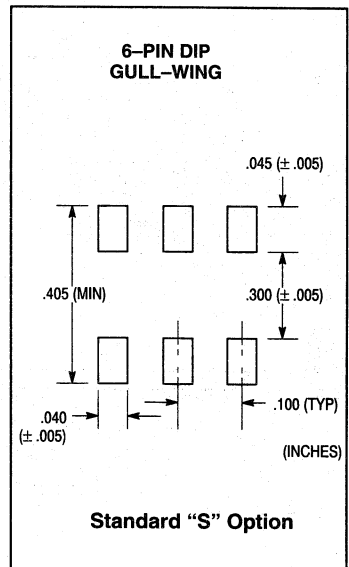
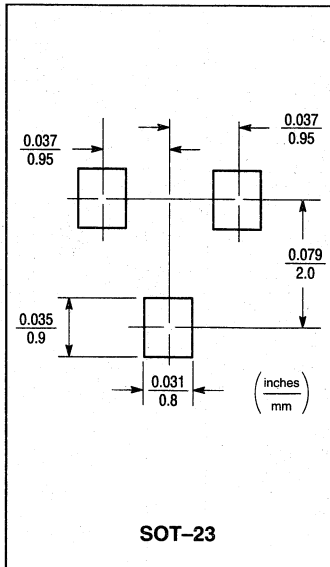
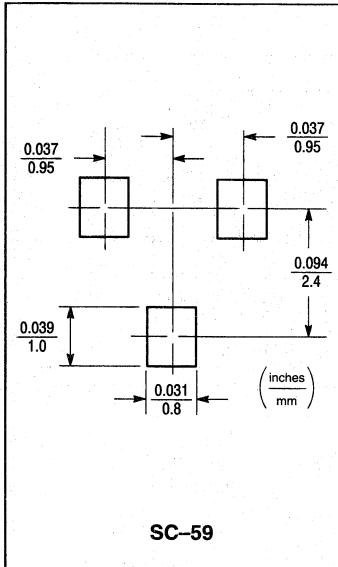

Figure 5. Typical Solder Heating Profile

5

# Footprints for Soldering



5

5

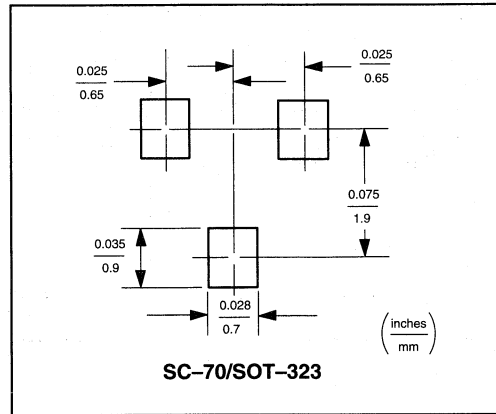
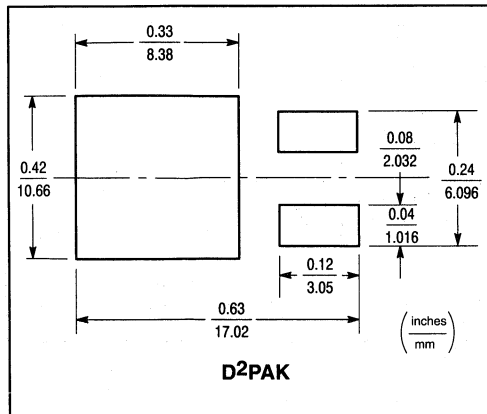
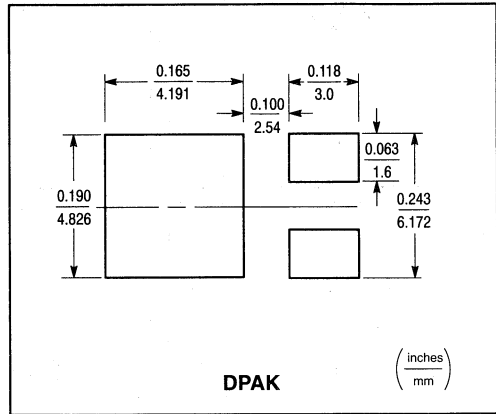
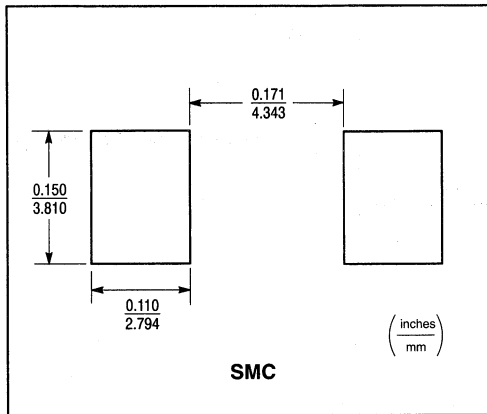
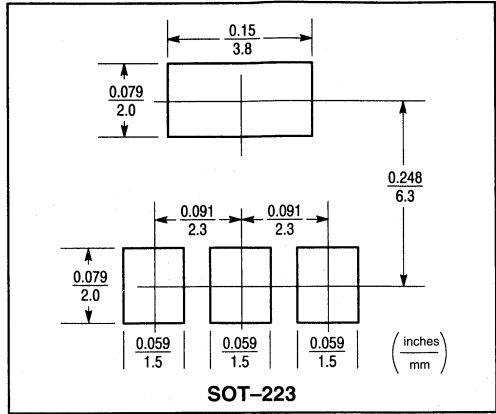
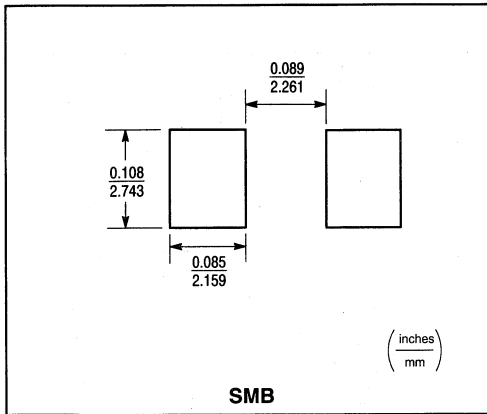

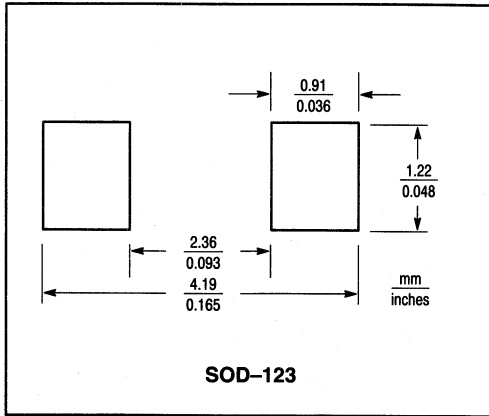



**5**

# Tape and Reel Specifications and Packaging Specifications

---

	<b>Page</b>
Tape and Reel Specifications .....	5.12-2
Embossed Tape and Reel Ordering Information .	5.12-3
Embossed Tape and Reel Data for Discretes ...	5.12-4
Lead Tape Packaging Standards for Axial-Lead Components .....	5.12-6
Packaging Specifications .....	5.12-7
TO-92 EIA Radial Tape in Fan Fold Box or on Reel .....	5.12-7
Fan Fold Box Styles .....	5.12-9
Adhesion Pull Tests .....	5.12-9
Reel Styles .....	5.12-10

**5**

# Tape and Reel Specifications and Packaging Specifications

Embossed Tape and Reel is used to facilitate automatic pick and place equipment feed requirements. The tape is used as the shipping container for various products and requires a minimum of handling. The antistatic/conductive tape provides a secure cavity for the product when sealed with the "peel-back" cover tape.

- Two Reel Sizes Available (7" and 13")
- Used for Automatic Pick and Place Feed Systems
- Minimizes Product Handling
- EIA 481, -1, -2
- SOD-123, SC-59, SC-70/SOT-323, SOT-23, SOT-143 in 8 mm Tape
- SO-8, OPTO SO-8, SOT-223, SMB in 12 mm Tape
- DPAK, SO-14, SO-16, SMC in 16 mm Tape
- D<sup>2</sup>PAK, 6-Pin Optoisolators in 24 mm Tape

Use the standard device title and add the required suffix as listed in the option table on the following page. Note that the individual reels have a finite number of devices depending on the type of product contained in the tape. Also note the minimum lot size is one full reel for each line item, and orders are required to be in increments of the single reel quantity.

5

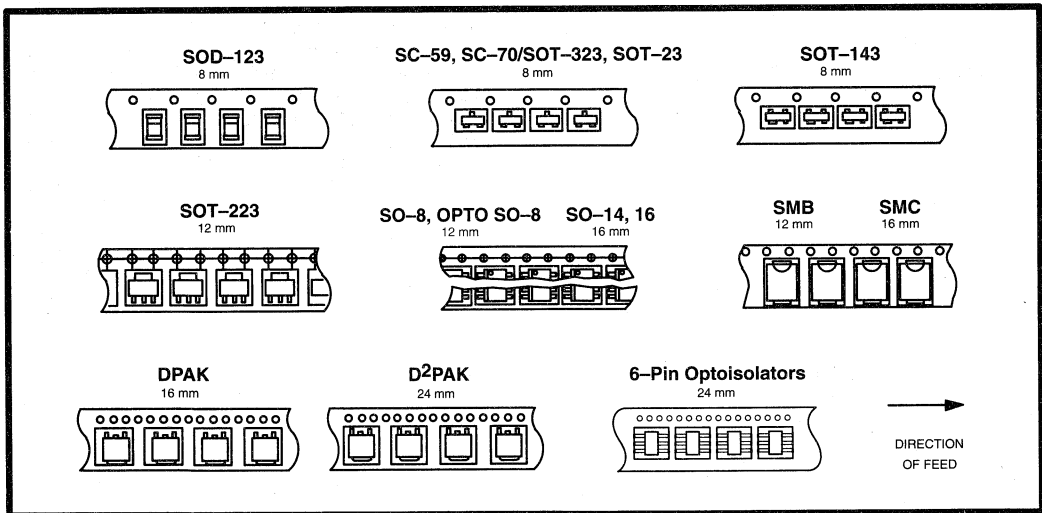

### EMBOSSED TAPE AND REEL ORDERING INFORMATION

Package	Tape Width (mm)	Pitch mm (inch)	Reel Size mm (inch)	Devices Per Reel and Minimum Order Quantity	Device Suffix
DPAK	16	8.0 ± 0.1 (.315 ± .004)	330 (13)	2,500	T4
D <sup>2</sup> PAK	24	16.0 ± 0.1 (.630 ± .004)	330 (13)	800	T4
SC-59	8	4.0 ± 0.1 (.157 ± .004)	178 (7)	3,000	T1
SC-70/SOT-323	8	4.0 ± 0.1 (.157 ± .004)	178 (7)	3,000	T1
	8		330 (13)	10,000	T3
SMB	12	8.0 ± 0.1 (.315 ± .004)	330 (13)	2,500	T3
SMC	16	8.0 ± 0.1 (.315 ± .004)	330 (13)	2,500	T3
SO-8, OPTO SO-8	12	8.0 ± 0.1 (.315 ± .004)	178 (7)	500	R1
	12		330 (13)	2,500	R2
SO-14	16	8.0 ± 0.1 (.315 ± .004)	178 (7)	500	R1
	16		330 (13)	2,500	R2
SO-16	16	8.0 ± 0.1 (.315 ± .004)	178 (7)	500	R1
	16		330 (13)	2,500	R2
SOD-123	8	4.0 ± 0.1 (.157 ± .004)	178 (7)	3,000	T1
	8		330 (13)	10,000	T3
SOT-23	8	4.0 ± 0.1 (.157 ± .004)	178 (7)	3,000	T1
	8		330 (13)	10,000	T3
SOT-143	8	4.0 ± 0.1 (.157 ± .004)	178 (7)	3,000	T1
	8		330 (13)	10,000	T3
SOT-223	12	8.0 ± 0.1 (.315 ± .004)	178 (7)	1,000	T1
	12		330 (13)	4,000	T3
6-Pin Optoisolators	24	12.0 ± 0.1 (.472 ± .004)	330 (13)	1000	R2

5

# EMBOSSED TAPE AND REEL DATA FOR DISCRETES

## CARRIER TAPE SPECIFICATIONS

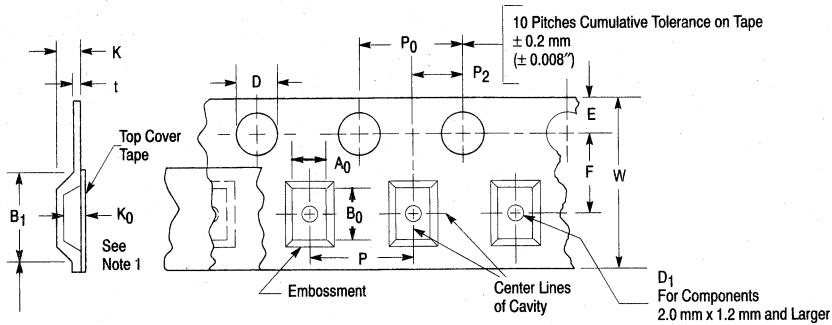

For Machine Reference Only  
Including Draft and RADII  
Concentric Around B<sub>0</sub>

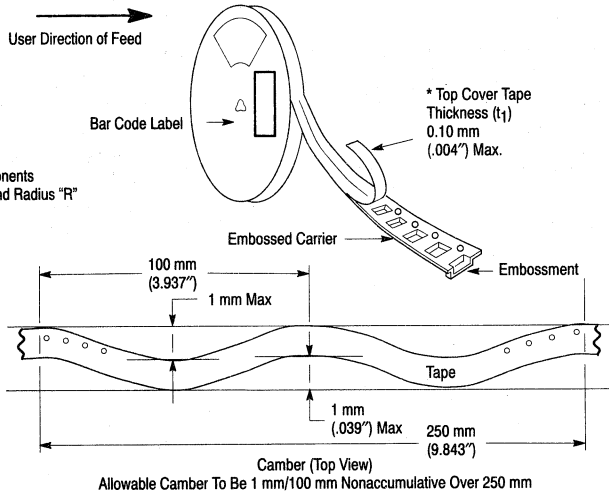
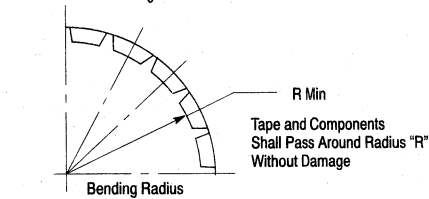

5

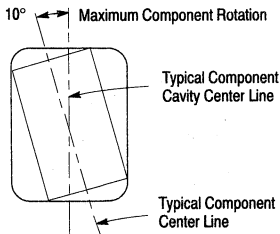

### DIMENSIONS

Tape Size	B <sub>1</sub> Max	D	D <sub>1</sub>	E	F	K	P <sub>0</sub>	P <sub>2</sub>	R Min	T Max	W Max
8 mm	4.55 mm (.179")	1.5 ± 0.1 mm - 0.0	1.0 Min (.039")	1.75 ± 0.1 mm (.069 ± .004")	3.5 ± 0.05 mm (.138 ± .002")	2.4 mm Max (.094")	4.0 ± 0.1 mm (.157 ± .004")	2.0 ± 0.1 mm (.079 ± .002")	25 mm (.98")	0.6 mm (.024")	8.3 mm (.327")
12 mm	8.2 mm (.323")	1.5 ± 0.1 mm (.059 ± .004") - 0.0	1.5 mm Min (.060")		5.5 ± 0.05 mm (.217 ± .002")	6.4 mm Max (.252")			30 mm (1.18")		12 ± .30 mm (.470 ± .012")
16 mm	12.1 mm (.476")				7.5 ± 0.10 mm (.295 ± .004")	7.9 mm Max (.311")					16.3 mm (.642")
24 mm	20.1 mm (.791")				11.5 ± 0.1 mm (.453 ± .004")	11.9 mm Max (.468")					24.3 mm (.957")

Metric dimensions govern — English are in parentheses for reference only.

NOTE 1: A<sub>0</sub>, B<sub>0</sub>, and K<sub>0</sub> are determined by component size. The clearance between the components and the cavity must be within .05 mm min. to .50 mm max., the component cannot rotate more than 10° within the determined cavity.

NOTE 2: If B<sub>1</sub> exceeds 4.2 mm (.165) for 8 mm embossed tape, the tape may not feed through all tape feeders.

NOTE 3: Pitch information is contained in the Embossed Tape and Reel Ordering Information on pg. 5.12-3.

## EMBOSSED TAPE AND REEL DATA FOR DISCRETES

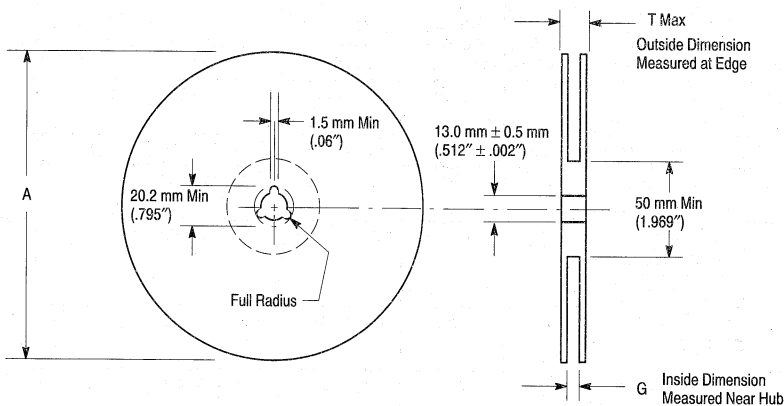

Size	A Max	G	T Max
8 mm	330 mm (12.992")	8.4 mm + 1.5 mm, -0.0 (.33" + .059", -0.00)	14.4 mm (.56")
12 mm	330 mm (12.992")	12.4 mm + 2.0 mm, -0.0 (.49" + .079", -0.00)	18.4 mm (.72")
16 mm	360 mm (14.173")	16.4 mm + 2.0 mm, -0.0 (.646" + .078", -0.00)	22.4 mm (.882")
24 mm	360 mm (14.173")	24.4 mm + 2.0 mm, -0.0 (.961" + .070", -0.00)	30.4 mm (1.197")

### Reel Dimensions

Metric Dimensions Govern — English are in parentheses for reference only

5

## LEAD TAPE PACKAGING STANDARDS FOR AXIAL-LEAD COMPONENTS

Case Type	Product Category	Device Title Suffix	MPQ Quantity Per Reel (Item 3.3.7)	Component Spacing A Dimension	Tape Spacing B Dimension	Reel Dimension C	Reel Dimension D (Max)	Max Off Alignment E
Case 17-02	Surmetic 40 & 600 Watt TVS	RL	4000	0.2 +/- 0.015	2.062 +/- 0.059	3	14	0.047
Case 41A-02	1500 Watt TVS	RL4	1500	0.4 +/- 0.02	2.062 +/- 0.059	3	14	0.047
Case 51-02	DO-7 Glass (For Reference only)	RL	3000	0.2 +/- 0.02	2.062 +/- 0.059	3	14	0.047
Case 59-03	DO-41 Glass & DO-41 Surmetic 30	RL	6000	0.2 +/- 0.015	2.062 +/- 0.059	3	14	0.047
	Rectifier							
Case 59-04	500 Watt TVS	RL	5000	0.2 +/- 0.02	2.062 +/- 0.059	3	14	0.047
	Rectifier							
Case 194-04	110 Amp TVS (Automotive)	RL	800	0.4 +/- 0.02	1.875 +/- 0.059	3	14	0.047
	Rectifier							
Case 267-02	Rectifier	RL	1500	0.4 +/- 0.02	2.062 +/- 0.059	3	14	0.047
Case 299-02	DO-35 Glass	RL	5000	0.2 +/- 0.02	2.062 +/- 0.059	3	14	0.047

**Table 1. Packaging Details (all dimensions in inches)**

5

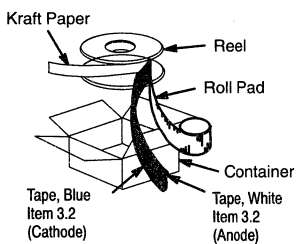

**Figure 1. Reel Packing**

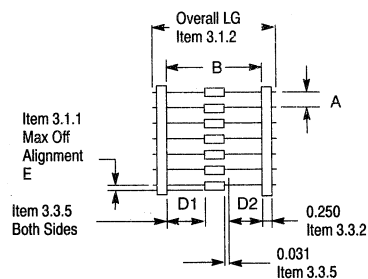

**Figure 2. Component Spacing**

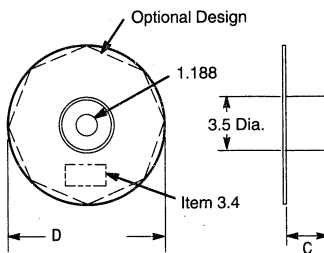
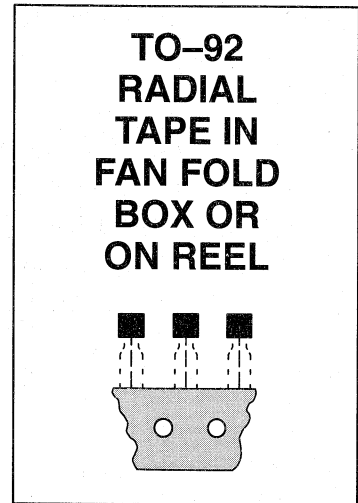

**Figure 3. Reel Dimensions**

## TO-92 EIA, IEC, EIAJ Radial Tape in Fan Fold Box or On Reel

Radial tape in fan fold box or on reel of the reliable TO-92 package are the best methods of capturing devices for automatic insertion in printed circuit boards. These methods of taping are compatible with various equipment for active and passive component insertion.

- Available in Fan Fold Box
- Available on 365 mm Reels
- Accommodates All Standard Inserters
- Allows Flexible Circuit Board Layout
- 2.5 mm Pin Spacing for Soldering
- EIA-468, IEC 286-2, EIAJ RC1008B



### Ordering Notes:

When ordering radial tape in fan fold box or on reel, specify the style per Figures 3 through 8. Add the suffix "RLR" and "Style" to the device title, i.e. MPS3904RLRA. This will be a standard MPS3904 radial taped and supplied on a reel per Figure 9.

Fan Fold Box Information — Minimum order quantity 1 Box/\$200LL.  
Order in increments of 2000.

Reel Information — Minimum order quantity 1 Reel/\$200LL.  
Order in increments of 2000.

5

### US/European Suffix Conversions

US	EUROPE
RLRA	RL
RLRE	RL1
RLRM	ZL1



## TO-92 EIA RADIAL TAPE IN FAN FOLD BOX OR ON REEL

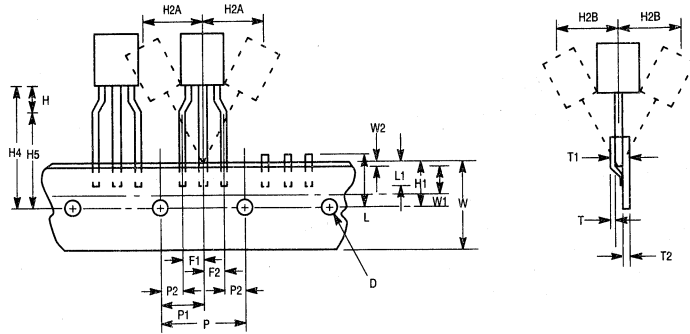

**Figure 1. Device Positioning on Tape**

Symbol	Item	Specification			
		Inches		Millimeter	
		Min	Max	Min	Max
D	Tape Feedhole Diameter	0.1496	0.1653	3.8	4.2
D2	Component Lead Thickness Dimension	0.015	0.020	0.38	0.51
F1, F2	Component Lead Pitch	0.0945	0.110	2.4	2.8
H	Bottom of Component to Seating Plane	.059	.156	1.5	4.0
H1	Feedhole Location	0.3346	0.3741	8.5	9.5
H2A	Deflection Left or Right	0	0.039	0	1.0
H2B	Deflection Front or Rear	0	0.051	0	1.0
H4	Feedhole to Bottom of Component	0.7086	0.768	18	19.5
H5	Feedhole to Seating Plane	0.610	0.649	15.5	16.5
L	Defective Unit Clipped Dimension	0.3346	0.433	8.5	11
L1	Lead Wire Enclosure	0.09842	—	2.5	—
P	Feedhole Pitch	0.4921	0.5079	12.5	12.9
P1	Feedhole Center to Center Lead	0.2342	0.2658	5.95	6.75
P2	First Lead Spacing Dimension	0.1397	0.1556	3.55	3.95
T	Adhesive Tape Thickness	0.06	0.08	0.15	0.20
T1	Overall Taped Package Thickness	—	0.0567	—	1.44
T2	Carrier Strip Thickness	0.014	0.027	0.35	0.65
W	Carrier Strip Width	0.6889	0.7481	17.5	19
W1	Adhesive Tape Width	0.2165	0.2841	5.5	6.3
W2	Adhesive Tape Position	.0059	0.01968	.15	0.5

**NOTES:**

1. Maximum alignment deviation between leads not to be greater than 0.2 mm.
2. Defective components shall be clipped from the carrier tape such that the remaining protrusion (L) does not exceed a maximum of 11 mm.
3. Component lead to tape adhesion must meet the pull test requirements established in Figures 5, 6 and 7.
4. Maximum non-cumulative variation between tape feed holes shall not exceed 1 mm in 20 pitches.
5. Holddown tape not to extend beyond the edge(s) of carrier tape and there shall be no exposure of adhesive.
6. No more than 1 consecutive missing component is permitted.
7. A tape trailer and leader, having at least three feed holes is required before the first and after the last component.
8. Splices will not interfere with the sprocket feed holes.

5

# TO-92 EIA RADIAL TAPE IN FAN FOLD BOX OR ON REEL

## FAN FOLD BOX STYLES

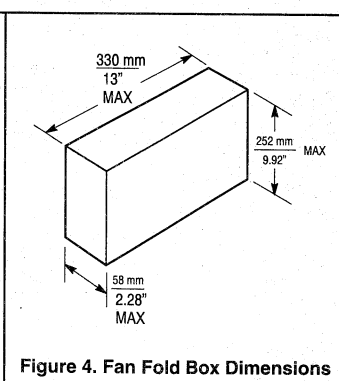
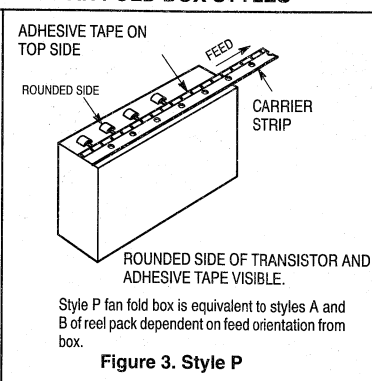
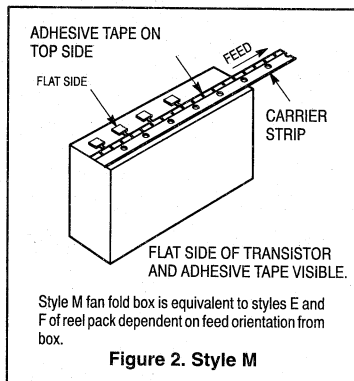

## ADHESION PULL TESTS

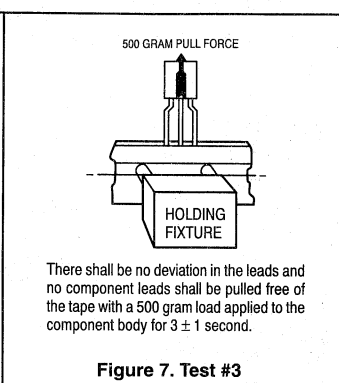
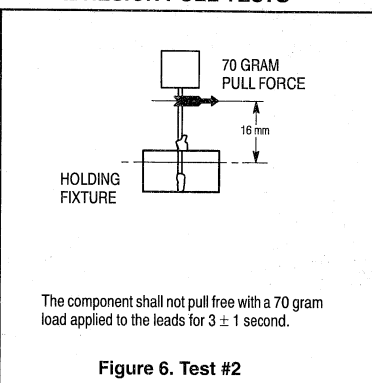
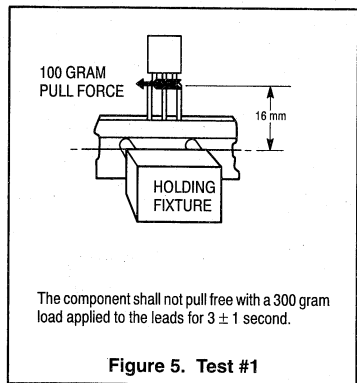

**5**

# TO-92 EIA RADIAL TAPE IN FAN FOLD BOX OR ON REEL

## REEL STYLES

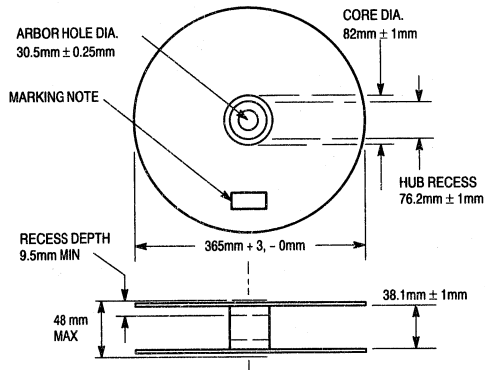

Material used must not cause deterioration of components or degrade lead solderability

**Figure 8. Reel Specifications**

**5**

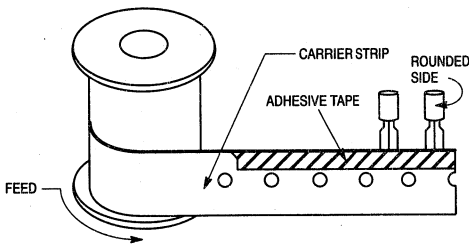

Rounded side of transistor and adhesive tape visible.

**Figure 9. Style A**

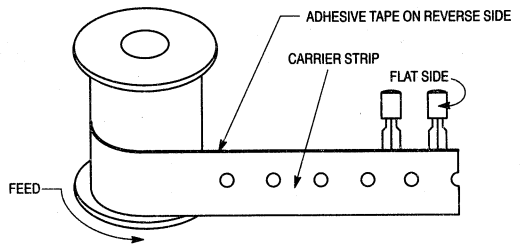

Flat side of transistor and carrier strip visible  
(adhesive tape on reverse side).

**Figure 10. Style B**

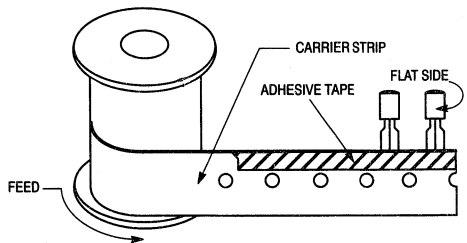

Flat side of transistor and adhesive tape visible.

**Figure 11. Style E**

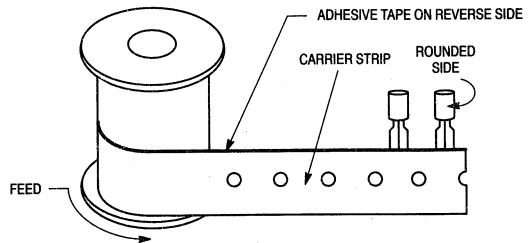

Rounded side of transistor and carrier strip visible  
(adhesive tape on reverse side).

**Figure 12. Style F**

# Leadform Options

---

## In Brief . . .

Plastic packaged semiconductors may be leadformed to a variety of configurations for insertion into sockets or circuit boards. Leadform options require assignment of a special part number before ordering. To order leadformed product, determine the desired leadform, the case number and applicable leadform number, then contact your local Motorola representative for the special part number and pricing. Leadform orders require a minimum order quantity and are non-cancellable after processing.

	<b>Page</b>
TO-92 (Case 29) & TO-225AA (Case 77) . . . . .	5.13-2
TO-220 (Case 221A) . . . . .	5.13-5
ICePAK Leadform Options . . . . .	5.13-10

# Leadform Options — TO-92 (Case 29) & TO-225AA (Case 77)

Plastic packaged semiconductors may be leadformed to a variety of configurations for insertion into sockets or circuit boards. Leadform options require assignment of a special part number before ordering. To order leadformed product, determine the desired leadform, the

case number and applicable leadform number, then contact your local Motorola representative for the special part number and pricing. Leadform orders require a minimum order quantity and are non-cancellable after processing.

**CASE 29  
LEADFORM 5\*  
(TO-92 to fit TO-5)**

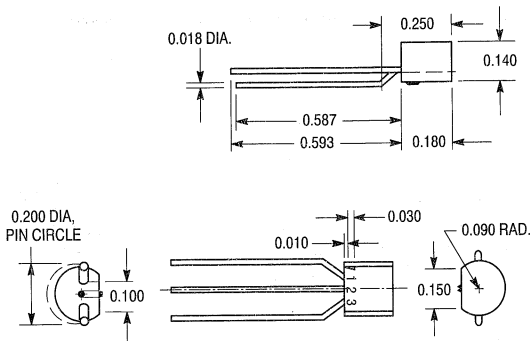

**CASE 29  
LEADFORM 18\*  
(TO-92 to fit TO-18)**

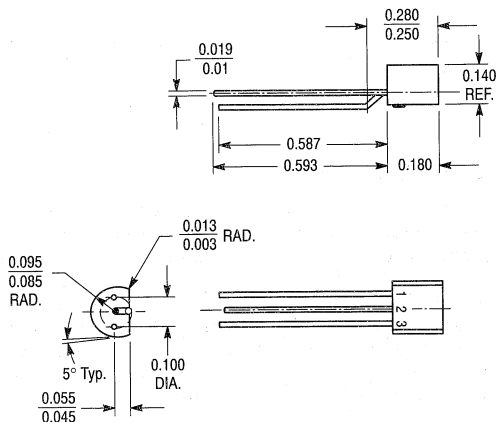

5

**CASE 77  
LEADFORM VA**

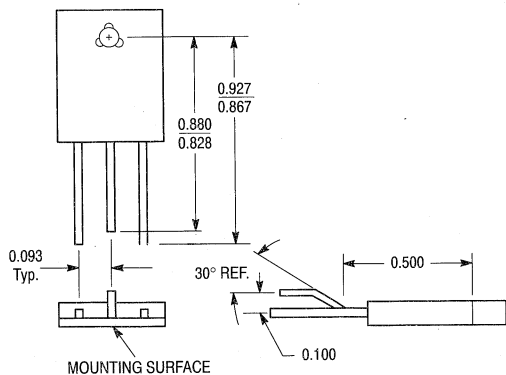

**CASE 77  
LEADFORM VB**

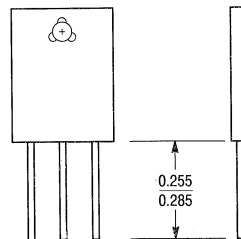

# TO-92 & TO-225AA Leadform Options (continued)

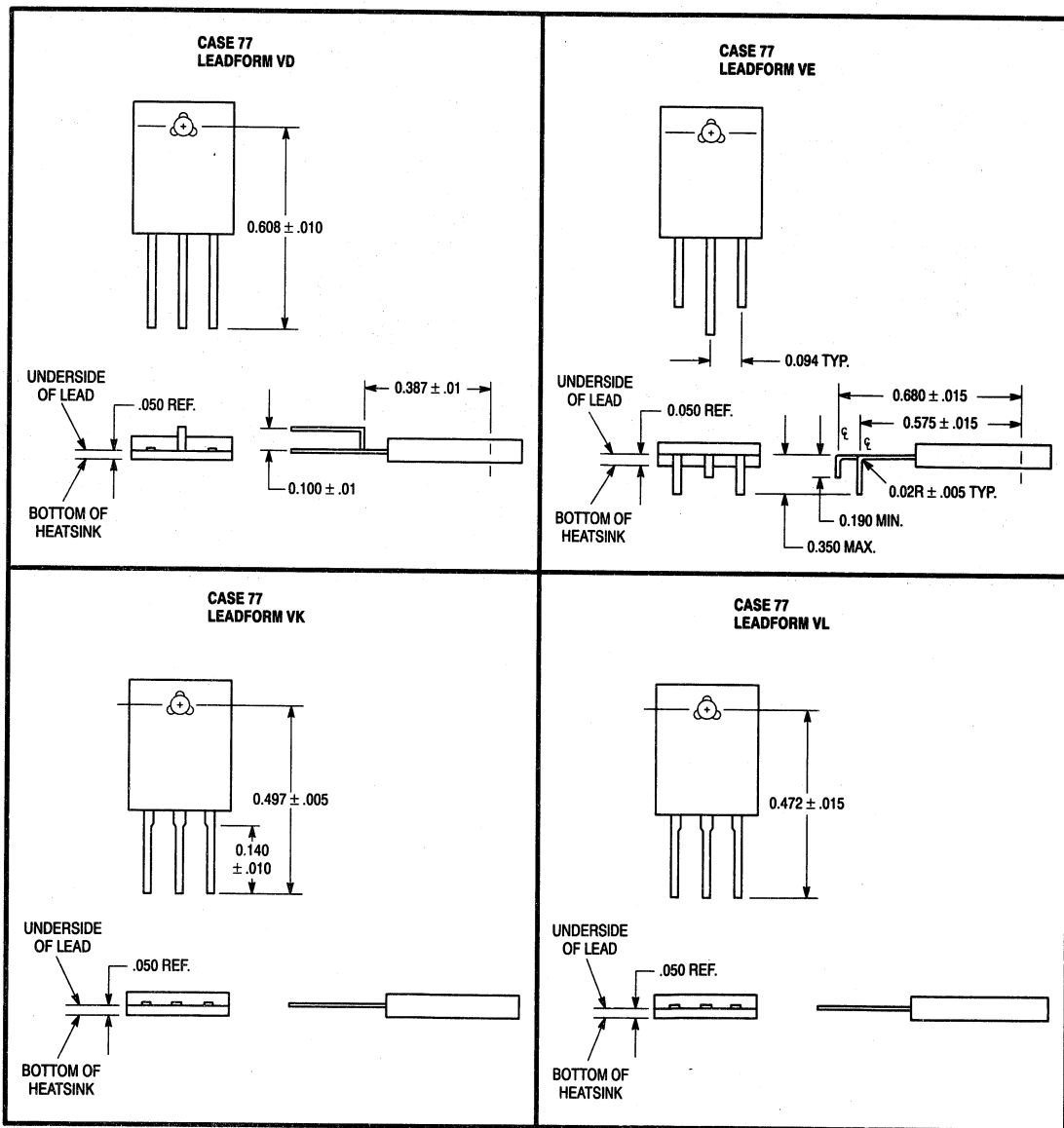

# TO-92 & TO-225AA Leadform Options (continued)

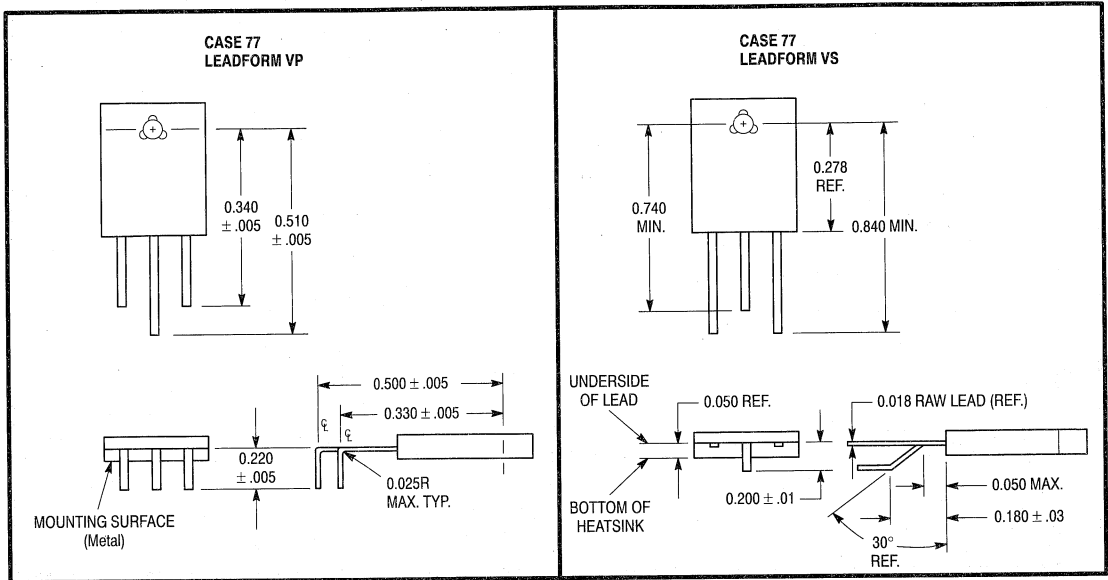

5

# Leadform Options — TO-220 (Case 221A)

- Leadform options require assignment of a special part number before ordering.
- Contact your local Motorola representative for special part number and pricing.
- 10,000 piece minimum quantity orders are required.
- Leadform orders are non-cancellable after processing.
- Leadforms apply to both Motorola Case 221A-04 and 221A-06 except as noted.

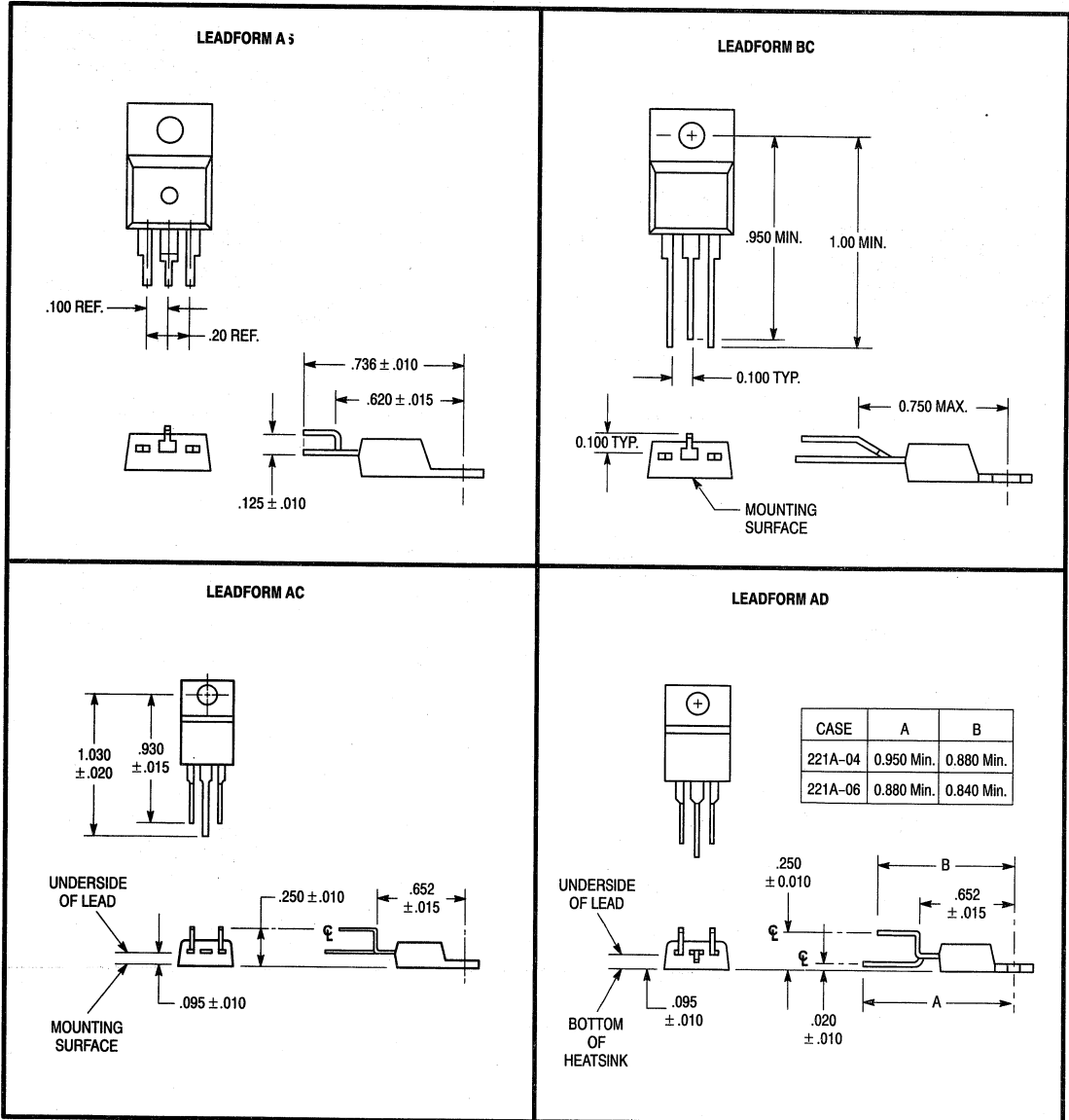

5



# TO-220 Leadform Options (continued)

LEADFORM AN

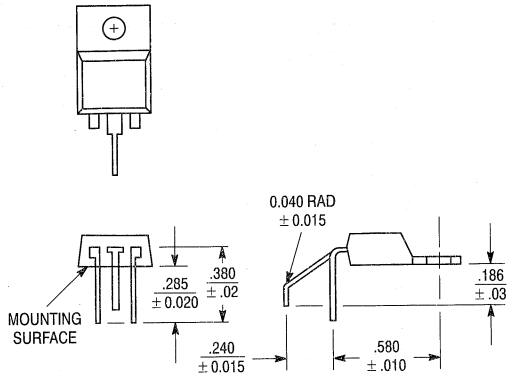

LEADFORM BA

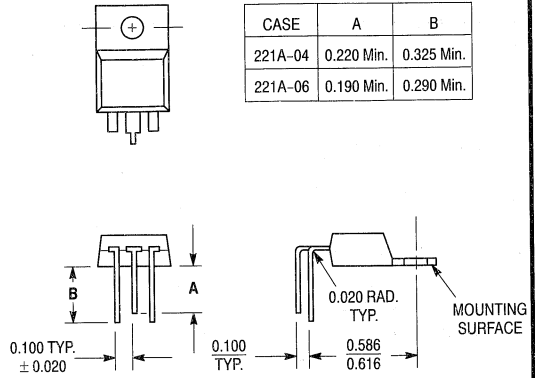

LEADFORM BL

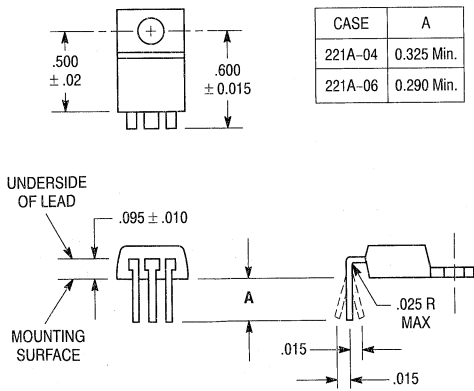

LEADFORM AK

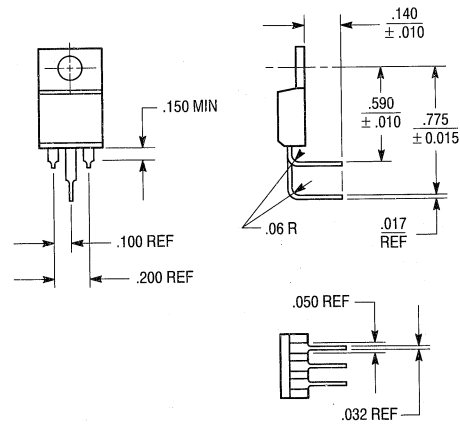

5

# TO-220 Leadform Options (continued)

**LEADFORM AF**

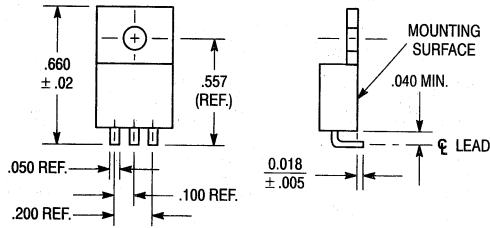

**LEADFORM BS**

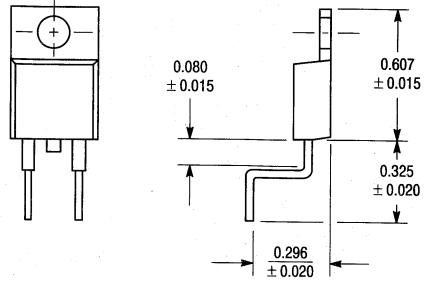

**LEADFORM BR**

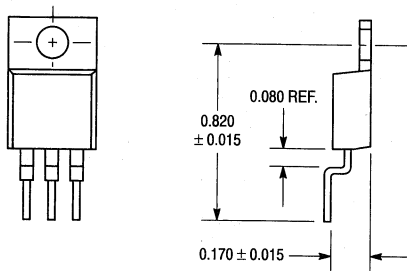

**LEADFORM AU**

CASE	A
221A-04	0.920 Min.
221A-06	0.885 Min.

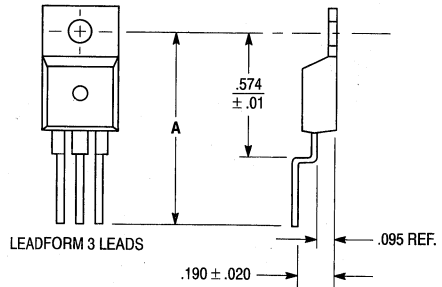

# TO-220 Leadform Options (continued)

LEADFORM BU

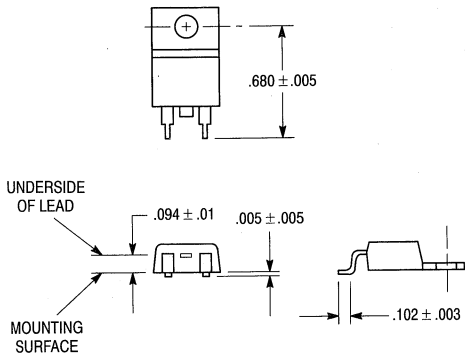

LEADFORM BV

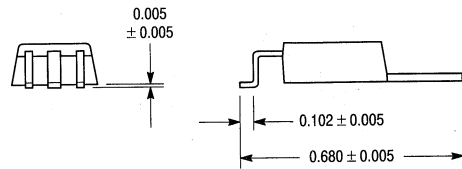

LEADFORM BD

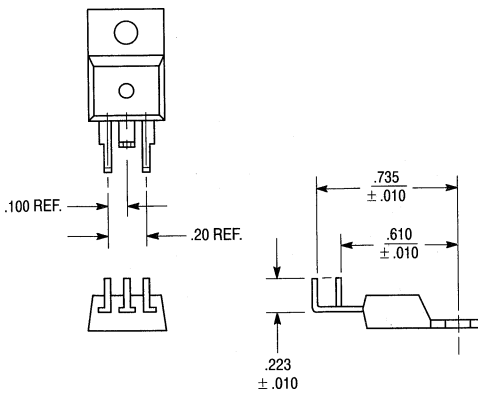

LEADFORM DW

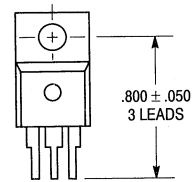

5

# TO-220 Leadform Options (continued)

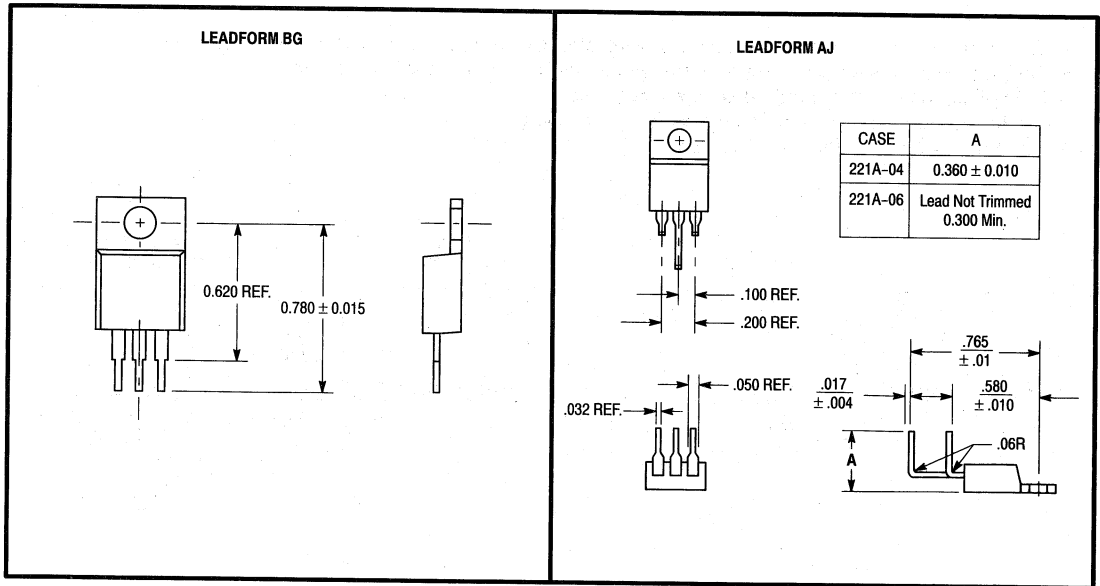

# ICePAK Leadform Options

- Leadform options require assignment of a special part number before ordering.
- Contact your local Motorola representative for special part number and pricing.
- 1350 piece minimum quantity orders are required.
- Leadform orders are non-cancellable after processing.
- Leadforms apply to Motorola Case 806

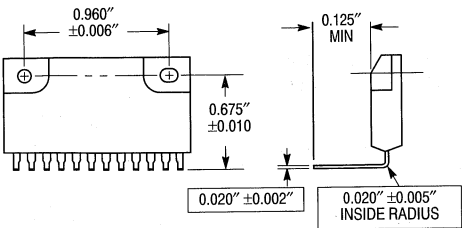

Leadform A

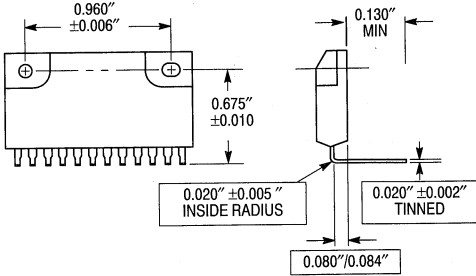

Leadform B

# CPTO Integrated Circuits, Discrete and International Products

---

## In Brief . . .

Motorola is one of the world's leading manufacturers of electronic equipment, systems and components. Motorola products include two-way radios, pagers, cellular and mobile telephones, defense and aerospace electronics, automotive and industrial equipment, data communications, information processing equipment and semiconductor products. Motorola is one of the few end-equipment manufacturers that can draw on a complement of government electronics and semiconductor technology.

Motorola has been an industry leader and consistent manufacturer of semiconductors since the advent of the technology, and has since emerged as a worldwide leader of leading-edge technology. Motorola's leadership position applies to products such as the 68000 series microprocessor including the 68060, the newest and most powerful member of the family, our DSP family including the DSP56001 and the new DSP96000, logic, linear, discrete, memory components, ASIC, and our state of the art 88000 RISC microprocessor, and the latest in MultiChip Modules.

"It is the policy of the Motorola Semiconductor Products Sector to produce products and provide services exactly according to CUSTOMER expectations, specifications and delivery schedule. Our system is based on prevention using statistical process control. The standard is a Six Sigma level of error-free performance. These results come from the participation efforts of each employee in conjunction with supportive participation from all levels of management."

Tommy George  
Executive Vice President and General Manager  
Semiconductor Products Sector

Our commitment to the commercial plus, aerospace and defense markets is supported by a complete line of semiconductor products. This material represents our RF products portfolio, which includes Discrete and MMIC devices.

	Page
General Information .....	6.1-1
CPTO Integrated Circuits .....	6.2-1
CPTO Discrete Products .....	6.3-1
CPTO International Products .....	6.4-1

6

We thank you for your interest in our products and the opportunity to support your requirements. Should you have questions or require further information, please contact your Motorola sales representative or our Service Center at 1-800-521-6274.

Sincerely,



Don Walker  
Vice President and Director  
Commercial Plus Technologies Operation

**6**

# General Information

## Process Flows\*

The process flows for our integrated circuit and discrete products are as follows:

JAN S	All discrete product assembled, screened and inspected per the applicable requirements of MIL-S-19500. Electrical parameters and marking requirements shall be as specified in the applicable detail specification. Product shall be manufactured in the U.S. on DESC certified lines. These products are most commonly produced for space applications.
Motorola S	All I/C product assembled, screened and inspected per the requirements of Motorola Processing Document 12MRM51815A. Electrical parameters and marking requirements shall be as specified in Motorola's Class S Master List: 48ARM51950A. Product shall be manufactured in the U.S. These products are most commonly produced for space applications, where fully compliant JANS is not required.
JAN	All discrete product assembled, and inspected per the applicable requirements of MIL-S-19500. Electrical parameters, test conditions, and marking requirements shall be as specified in the applicable detail specification. Product may be assembled in DESC approved off-shore facilities. Testing shall be done in the USA using DESC qualified facilities. These products are presently being removed from the QPL as the detail specifications are being revised. Recommended replacement is the JANTX level.
JAN B	All IC product assembled, screened and inspected per the applicable transition certification requirements of MIL-I-38535. Electrical parameters and marking requirements shall be as specified in the applicable detail specification. Product shall be manufactured in the U.S. on a DESC certified line. These products are produced for military applications.
JAN TX	All discrete product assembled, screened and inspected per the applicable requirements of MIL-S-19500. Electrical parameters, test conditions and marking requirements shall be as specified in the applicable specification. Product assembly and high temperature storage life may be done in DESC approved off-shore facilities. Screening and testing must be done in the USA on DESC certified lines. These products are produced for general military applications.
JAN TXV	All discrete product assembled, screened and inspected per the applicable requirements of MIL-S-19500. Electrical parameters, test conditions and marking requirements shall be as specified in the applicable detail specifications. Product must be assembled in DESC approved USA facilities. Testing shall be performed in the USA using DESC qualified facilities. These products are recommended when higher level of reliability than JTX is required.
SMD	All IC product assembled, screened, inspected and certified to the transition certification requirements of MIL-I-38535. Electrical parameters and marking requirements shall be as specified in the SMD. These products are produced for military applications.

6

\* Generic and Lot Traceability Data are provided at a nominal fee. Please contact your local sales office or the Service Center for more information.



## Process Flows\* (continued)

DESC Drawings	All discrete product assembled, screened and inspected per the applicable requirements of MIL-S-19500. Electrical parameters and test conditions are specified in the detail specification. Fabrication, assembly, screening and testing are not limited to USA facilities. These products are produced for all levels of military applications where no MIL-S-19500 detail specification exists. DESC drawings are similar to SMD devices for integrated circuits.
883	All I/C product assembled, screened and inspected per the transition certification requirements of MIL-I-38535 or per the requirements of Paragraph 1.2.1 of MIL-STD-883 (as applicable). Electrical parameters shall be as specified in the applicable detail specification. Marking shall be in accordance with JEDEC Publication 101. These products are produced for military applications.
MIL-Processed	All discrete product assembled, screened and inspected per the applicable requirements of MIL-S-19500. Electrical parameters and test conditions are specified in the Motorola military data sheet. Assembly, screening and testing are not limited to USA facilities. These products are produced for all levels of military applications where no MIL-S-19500 detail specification exists.

## Rewarranty Policy

### CPTO Solderability Warranty Policy

Per the new requirements of paragraph 4.2 of MIL-I-38535J, microcircuits held by manufacturers or distributors for a period exceeding 36 months from the date of the inspection lot identification code (date code) shall be demonstrated to be solderable in accordance with subgroup B-3 of test method 5005 of MIL-STD-883 prior to shipment.

Implementation date for this requirement was May 15, 1992; therefore, all product processed per the requirements of MIL-I-38535 and M5005 of MIL-STD-883 with date code 9220 or newer shall be processed in accordance with this requirement. However, all product with date codes 9219 or older shall be grandfathered and will not be processed in accordance with this requirement (Product shall not be returned to Motorola for rewarranty). For grandfathered

product (product with date codes 9219 or older), Motorola shall guarantee the solderability of these parts. If these parts are not solderable at the customer's incoming inspection, Motorola will either rework or replace the parts free of charge.

The new warranty requirements shall be in effect for product with date codes 9220 or newer, and the following criteria shall apply:

- The entire lot shall be returned for rewarranty
- The returned lot shall be included in the distributor's allotted DSA for the month that the product was returned
- Commercial Plus Technologies Operation has the right to either replace or rework the material being returned

6

\* Generic and Lot Traceability Data are provided at a nominal fee. Please contact your local sales office or the Service Center for more information.

## CPTO Class "S" Product Assurance Requirements

Motorola offers a higher level of IC processing than 883 Class B for our customers' use patterned after the 38535 Class "S" flow. This process captures the essence of 38535 "S" in most all methods and is particularly useful to customers requiring JAN "S" devices but are unable to obtain them. This

process is completely captured in Motorola Specification 12MRM51815A and is available to our customers upon request. A comparison of JAN "S", JAN "B" and Motorola's basic requirements appears in the table below.

**Table 1. CPTO Class "S" Product Assurance Requirements**

Requirements	JAN 38510		Motorola Class "S" (12MRM51815A)
	Class "S"	Class "B"	
Qualifications, General			
Line Certification	X	X	
Device & Package Qual.	X	X	X (By CPTO)
Change Control	X	X	X
Wafer Lot Acceptance	X	—	X (Per internal spec Similar to 5007. SEM or Current Density)
Traceability	X	X	X
GSI	X	X	X
Inprocess Inspection	X	X	X
Screening (5004)			
Precap Visual	2010A (GSI/CSI)	2010B or Alt. Per 38510	(CSI/GSI) 2010A with modifications specified in (12MRM51815A)
Temp. Cycle	X	X	X (50 Cycle Min. when alternate inspection is used.
Constant Acceleration	X	X	X
PIND	X	—	X
Serialization	X	—	X (Lot Size Not Limited)
Interim Electrical	X	—	X
Burn-In	240 Hrs.	160 Hrs. or Equivalent	240 Hrs. or Equivalent
Seal (Fine/Gross Leak)	X	X	X
Final Electrical	X	X	X
Radiographic	X	—	X
External Visual	X	X	X
Non Destruct 100% Bond Pull	X	—	*
Quality Conformance (5005)	X	X	X
Group A (Each Lot/Sublot)	X	X	X
Group B (Each Lot)	X	X or Alt. B	X or Alt. B
Group D	X	X	X (Note 1)

(X Indicates Requirement)

\* Sample basis only for high pin count devices.

Note:

1. Shipment prior to completion of groups B, D, with customer approval.

6

**Table 2. Military Standard Process Flows**

Screen	STANDARD MIL DRAWING (SMD) and MIL-STD-883		MIL-I-38535 JAN	
	Method	Requirement	Method	Requirement
Internal Visual (Precap)	2010 Condition B and 38510(1)	100%	2010 Condition B and 38510(1)	100%
Temperature Cycling	1010 Condition C	100%	1010 Condition C	100%
Constant Acceleration	2001 Condition E (min.) in Y 1 Plane(2)	100%	2001 Condition E (min.) in Y 1 Plane(2)	100%
Seal Fine Leak	1014, Condition B(8)	100%	1014, Condition B(8)	100%
Seal Fluorocarbon Gross Leak	1014, Condition C(8)	100%	1014, Condition C3(8)	100%
Interim Electrical	Per applicable device specification	Optional	JAN slash sheet electrical specification	Optional
Burn-In Test	1015 160 hours @ 125°C or equivalent(3)	100%	1015 160 hours @ 125°C or equivalent(3)	100%
Final Electrical Tests (A) Static Tests 1. 25°C (Subgroup 1) 2. Max & Min rated operating temperature (Subgroups 2 & 3)(7) (B) Dynamic Test or Switching Tests 1. 25°C (Subgroup 4 or 9) (C) Functional 1. 25°C (Subgroup 7, -55° and +125°C (Subgroup 8))	Per applicable device specification	100% 100% 100% 100%	JAN slash sheet electrical specifications	100% 100% 100% 100%
Quality Conformance Inspection Group A (A) Static 1. 25°C (Subgroup 1) 2. Temperature (Subgroup 2 & 3) (B) Dynamic Test or Switching Tests 1. 25°C (Subgroup 4 or 9) 2. Temperature (Subgroup 5 & 6 or 10 & 11)(4) (C) Functional 1. 25°C (Subgroup 7, -55° and +125°C (Subgroup 8))	Per applicable device specification  5005 Class B	  (4)	JAN slash sheet electrical specifications  5005 Class B	  (4)
Group B	5005 Class B	(5)	5005 Class B	(5)
Group C	5005 Class B	(6)	5005 Class B	Every 4th quarter
Group D	5005 Class B	(6)	5005 Class B	26 wks pkg prod
External Visual	2009	100%	2009	100%

**6**

- (1) Alternate screens per Paragraph 3.3 of Method 5004, MIL-STD-883 will be used on bipolar logic and MECL memory product.
- (2) For packages with cavity perimeter of  $\geq 2$  inches or a package mass  $\geq 5$  grams, or per JAN slash sheet/SMD, lesser stress levels will be used.
- (3) Burn-in time/temperature per Table 1 of Method 1015, MIL-STD-883. PDA per method 5004, MIL-STD-883.
- (4) When limits are available per applicable device specifications. For SSI Class B Devices, tests are performed as a part of Group C. For MSI and greater complexity Class B devices, tests are performed as a part of Group A.
- (5) Each package and lead finish for each lot of each assembly location.
- (6) JAN generic data may be used. If JAN generic data is not available, Group C/Group D inspection shall be periodically performed per general provisions paragraph 1.2.1 of MIL-STD-883.
- (7) Lead Finish "A" applied after post burn-in electrical (A1) but before the final static electrical insertion.
- (8) Fine and Gross leak may be performed anywhere between constant acceleration and external visual.

**Table 3. Commercial Plus Options**

FLOW OPERATIONS	Commercial Plus			Avionics		MEP	883	
	3			2		1		
* Operating Conditions	0°C to 70°C	- 40°C to 85°C	- 55°C to 125°C	- 40°C/- 55°C to 85°C	- 55°C to 125°C	- 55°C to 125°C		
Operation	* The focus of these flows is to provide the operating temperature the customer needs.  * As a minimum, assembly will follow commercial practices.  * Commercial Plus products feature value-added services (interim electricals, temperature testing, burn-in, post burn-in screening, packaging, etc.) not available from other Motorola Commercial Strategic business units.			• As a minimum, assembly will follow commercial practices.				
Die Inspection								
Die Bond								
Wire Bond								
Pre-Cap Visual								
Package Seal								
Temperature Cycle				√	√	√	√	
Centrifuge						√	√	
Interim Electrical					√	√	√	
Burn-In					160 hr @ 125°C or equivalent	160 hr @ 125°C or equivalent	160 hr @ 125°C or equivalent	160 hr @ 125°C or equivalent
Post Burn-In/Group "A"					25°C	25°C	√	√
Post Burn-In/Group "A"					85°C	125°C	√	√
Post Burn-In/Group "A"					- 40°C	- 55°C	√	√
Fine and Gross Leak					√	√	√	√
Solder							√	√
Solderability Test				√	√			
Marking				√	√			
External Visual Inspection				√	√			
Visual/Mechanical AOQ Sample				√	√			
QCI Testing				LIMITED	√			
Group "A" each Lot				In-Line	In-Line			
Group "B" each Lot				√	√			
Group "C" Periodic					√			
Group "D" Periodic					√			
C of C				√	√			

**6**

\* Per applicable device specification.

**Motorola Device Suffix Designators**

**Logic and Analog Integrated Circuits**

- |      |  |      |   |
|------|--|------|---|
| A, B | When followed by a package suffix, indicates improved device or die shrink   | K    | Metal power package (T0-3 type)   |
| A    | 14 pin dual-in-line plastic package (N, NE, ULN prefix devices only)   | N, P | Plastic dual-in-line package (P also used for Analog devices in T0-92 package)  |
| B    | 16 pin dual-in-line plastic package (N, NE prefix devices only); when followed by a package suffix, indicates automotive temperature range | P1   | 8-pin dual-in-line plastic package  |
| C    | When followed by a package suffix, indicates commercial temperature range  | P2   | 14-pin dual-in-line plastic package   |
| CDT  | DPAK SOIC (Small Outline I.C.) package (Regulators only)   | R    | Metal power package (T0-66 type)  |
| D    | SOIC (Small Outline I.C.) package; when used after a package suffix, indicates "BETTER" Program processing                                 | R2   | 13" tape & reel indicator, used only following CDT, D, DW, or FN package suffix |
| DW   | Wide-body SOIC (Small Outline I.C.) package  | RA   | Tape & reel indicator, style A, for T0-92 package                               |
| FN   | PLCC (Plastic Leaded Chip Carrier) package   | RB   | Tape & reel indicator, style B, for T0-92 package                               |
| G, H | Metal can package  | RE   | Tape & reel indicator, style E, for T0-92 package                               |
| J, L | Ceramic dual-in-line package   | RP   | Ammo pack indicator for T0-92 package   |
|      |  | T    | 3-pin plastic package (T0-220)  |
|      |  | U    | 8-pin dual-in-line ceramic package  |
|      |  | V    | 8-pin dual-in-line plastic package (NE prefix devices only)                     |

# Commercial Plus Technologies Operations

## Options

Motorola CPTO seeks Volume Military, Industrial and Commercial business not now available from other Motorola units or the open market:

- Product: High-End (MPU, MCU, etc.), Telecom, ASIC, Memory, Modules, Selected Logic/Analog, and Custom.
- Packages: Plastic or Ceramic – Focused on industry standards.
- Assembly: Per table of options.
- Operating Temperature: See Numbering System Chart below.
- Burn-In: Per 883 or Commercial Standard.
- Lead Finish: Typically will be the Commercial Standard or Military lead finish currently in use.  
Is negotiable, because burn-in may degrade lead finish.
- MEP is the same as 883/QML, except without redundant, non-value added activities.
- Change notification will be the same as that for 883 products.

### Numbering System (Excluding ASIC)

Motorola part numbers are limited to 16 characters. When needed the Slash Mark, Dash, and/or Lead Finish may be deleted.

**68332—16/XXXX(X) X**

#### Package Type

P = Plastic  
C = Ceramic

#### (1) Operating Conditions

A = - 55 °C to + 125 °C  
B = - 40 °C to + 85 °C  
C = 0 °C to + 70 °C

#### Option

1 = Option 1  
2 = Option 2  
3 = Option 3

#### (2) Lead Finish

A = Hot solder dip  
B = Tin plate  
C = Gold plate

#### Package Detail (1 or 2 Character(s))

(Combination of MIL-STD and Motorola Package Designators)

Examples:

R = 20 pin DIP (MIL-STD-1835)  
FN = Plastic Leaded Chip Carrier (Motorola)  
ZW = Pin Grid Array without Standoffs (Motorola)

Notes:

- (1) Per applicable device specification.
- (2) Per applicable package type.

**6**

**Table 4. Case Outline Table**

Case Outline Table			**Motorola Case Outline Table
Letter	MIL-M-1835 Designation	Description	M = Motorola designation for the 75 MIL Multi-Layer Leadless Chip Carrier, (Meets C2a Designation Criteria).  Example: M/BXXJC
A	F-1	14-lead FP (1/4" x 1/4")	Example: M/BXXJC
B	F-3	14-lead FP (3/16" x 1/4")	
C	D-1	14-lead DIL (1/4" x 3/4")	
D	F-2	14-lead FP (1/4" x 3/8")	
E	D-2	16-lead DIL (1/4" x 7/8")	
F	F-5	16-lead FP (1/4" x 3/8")	
G	A-1	8-lead CAN	
H	F-4	10-lead FP (1/4" x 1/4")	
I	A-2	10-lead CAN	
J	D-3	24-lead DIL (1/2" x 1-1/4")	
K	F-6	24-lead FP (3/8" x 5/8")	
L	D-9	24-lead DIL (1/4" x 1-1/4")	
*M	A-3	SMD/JAN — See detail dwg.	
*N		SMD/JAN — See detail dwg.	
P	D-4	8-lead DIL (1/4" x 3/8")	
Q	D-5	40-lead DIL (9/16" x 2-1/16")	
R	D-8	20-lead DIL (1/4" x 1-1/16")	
S	F-9	20-lead FP (1/4" x 1/2")	
*T		SMD/JAN — See detail dwg.	
*U		LCCC for Motorola 883	
*U		SMD/JAN — See detail dwg.	
V	D-6	18-lead DIL (1/4" x 15/16")	
W	D-7	22-lead DIL (3/8" x 1-1/8")	
*X		DIL for Motorola 883	
*X		SMD/JAN — See detail dwg.	
*Y		FP for Motorola 883	
*Y		SMD/JAN — See detail dwg.	
*Z		PGA or Metal Can for Motorola 883	
*Z		SMD/JAN — See detail dwg.	
2	C-2**	20-Terminal SQ. LCCC (.350" x .350")	
3	C-4	28-Terminal SQ. LCCC (.450" x .450")	Check with your local Motorola representative for price and delivery.

\*Undesignated in MIL-M-1835.

**Motorola Device Suffix Designators**

**MPU, MCU, DSP and Memories**

A, B, C	When followed by a package suffix, indicates improved device or die shrink	N	Narrow SOJ package (new notation)
C	When followed by a package suffix, indicates industrial temperature range (follows package suffix for FSRAMs)	NJ	Narrow SOJ package (old notation)
EM	QFP 240-pin plastic	P	Plastic dual-in-line package
FB	PQFP (Plastic Quad Flat Pack) package	R	PGA (Pin Grid Array) package, select plate tin finish leads
FC, FG, FU	PQFP (Plastic Quad Flat Pack) package, gull-wing	RC	PGA (Pin Grid Array) package, full gold finish leads
FE, FJ, FS	CQFP (Ceramic Quad Flat Pack) package, gull-wing	RL	Glass seal ceramic PGA (Pin Grid Array) package, tinned leads
FM	Molded Carrier Ring (MCR)	RP	Plastic PGA (Pin Grid Array) package
FN	PLCC (Plastic Lead Chip Carrier) package	R2	13" tape & reel indicator, used only following a surface-mount package suffix
FT	28 x 28MM Quad Flat Pack (QFP)	S	Ceramic dual-in-line package (microprocessors); SIMM (Single In-Line Memory Module) pack. (memory modules)
I	0 to 85 °C Temp. Range	SG	SIMM (Single In-Line Memory Module) package, gold pads
J	SOJ package (350-mil for 4M DRAM, 300-mil for all other memories)	SH	Low-height SIMM (Single In-Line Memory Module) pack.
KB	Ceramic PGA w/ceramic lid	SHG	Low-height SIMM (Single In-Line Memory Module) package, gold pads
L	Ceramic dual-in-line side-brazed package, or for 48-pin devices or larger, refers to select plate tin finish leads (microprocessors); SIP (Single In-Line Package) package (memory modules)	TH	16 x 16mm Quad Flat Pack (QFP)
LC	For 48-pin devices or larger, refers to full gold finish leads	V	- 40 to + 105 °C
LH	Low-height SIP (Single In-Line Package) package	WJ	400-mil SOJ package for FSRAMs
M	- 40 to + 125 °C	Z	Chip carrier package (microprocessors); Zig-zag leaded module (memory modules)
		ZB	LCC (Leadless Chip Carrier) package

**6**

**Table 5. 100% Processing Requirements for JANTX, JANTXV and JANS Products**

Inspections and tests must be performed in the order specified.

Subgroup Screen	MIL-STD-75 0 Test Method	JANTX	JANTXV	JANS
Internal Visual	2072/3/4	N/A	100%	100%
High Temperature Storage	1032	OPT	OPT	OPT
Temperature Cycling	1051	100%	100%	100%
Constant Acceleration	2006	OPT	OPT	100%
P.I.N.D.	2052	N/A	N/A	100%
Hermetic Seal	1071	100%	100%	OPT
Serialization	—	N/A	N/A	100%
Electricals, Read & Record		Go/No-Go	Go/No-Go	100%
H.T.R.B.				
Transistors	1039	100%	100%	100%
Power FETS	1042	100%	100%	100%
Electricals, Read & Record		100%	100%	100%
Power Burn-In				
Transistors	1039	160 Hrs	160 Hrs	240 Hrs
Power FETS	1042	160 Hrs	160 Hrs	240 Hrs
Electricals, Detail Spec		100%	100%	100%
Deltas, within 96 Hrs		100%	100%	100%
Hermetic Seal	1071	Optional	Optional	100%
X-Ray	2076	N/A	N/A	100%
External Visual	2071	N/A	N/A	100%

The above tests shall be followed by Group A, B and C tests on a sample basis.  
N/A = Not Applicable

6

## Process Flows: Certificate of Compliance

### **“The following policy change refers to the Military Integrated Circuit Products only”**

We have recently designed and implemented a new and improved data information packet to be shipped with each lot. It is much more concise, easier to understand, and clearer in format than the bulky, complicated report we previously provided. The reverse side of this notice is more generic in nature, but provides the “essentials” in terms of lot identification, military methods utilized for processing, and a clear summarization of the different steps the product goes through prior to shipment. Also on the same form is the required certificate of compliance.

We understand that for a very small percentage of customers who have specific attribute data requirements imposed on them by contract, this lot data may be insufficient. In those limited cases, we will be happy to research the records and provide “supplementary” data which consists of more specific lot history on Groups A, B, C and D and any extra processing which may have been completed; however, there will be a charge of \$300.00 per shipment for this additional information effective January 1, 1990, and will require a separate line item entry.

For further information please contact your local sales office or Service Center at 1-800-521-6274.

6



**Process Flows: Certificate of Compliance (continued)**

**Lot Data and Certificate Of Compliance**

SMD/MOTOROLA P/N: **JM38535/33201BRA**      CUSTOMER P/N: **990-3525-064**  
REVISION: **2**  
CUSTOMER NAME: **T.C.S. CORP.**      FACTORY ORDER #: **441019**  
CUSTOMER P.O.: **INLE-2789-707**      FACTORY O/L #: **01 00**  
QUANTITY: **10,000**

**T.C.S. CORP.  
PRODUCTION AVENUE  
TEMPE, AZ 85284**

LOT NO	SEAL/SOLDER D/C	RESOLDER D/C	SOLDER VERF. DATE	QUANTITY
<b>DM311W0806</b>	<b>QQ9328</b>	<b>NA</b>	<b>NA</b>	<b>10000</b>

IT IS HEREBY CERTIFIED THAT ALL ARTICLES LISTED ABOVE ARE IN THE QUANTITIES SHOWN AND ARE IN COMPLIANCE WITH ALL OF THE SCREENING AND QUALITY CONFORMANCE INSPECTION REQUIREMENTS OF MIL-M-38510, MIL-STD-883 (PARA 1.2.1 FOR SMD AND 883 PRODUCTS) AND MIL-I-38535 (FOR DEVICES CONTAINING A "Q" QML CERTIFICATION MARK) AND THE APPLICABLE DETAIL SPECIFICATIONS. RECORDS OF TRACEABILITY, INSPECTION, AND TEST PROVIDING OBJECTIVE EVIDENCE OF THE FOREGOING ARE ON FILE AT MOTOROLA AND ARE AVAILABLE UPON REQUEST.

**6**

\_\_\_\_\_  
QUALITY ASSURANCE INSPECTOR

DATE: \_\_\_\_\_

JAN/SMD/JEDEC

SCREENING AND INSPECTION REQUIREMENTS ON NEXT PAGE

## Certificate of Compliance (continued)

### Screening And Inspection Requirements for Motorola's JAN/SMD/883/JEDEC Programs

<p><b>OPERATION</b> INTERNAL VISUAL TEMPERATURE CYCLING CONSTANT ACCELERATION FINE &amp; GROSS LEAK BURN-IN FINAL ELECTRICAL</p>	<p><b>100% SCREENING PER METHOD 5004, MIL-STD-883, LEVEL B:</b> METHOD 2010 CONDITION B AND PARA. 3.3.1 OF M5004, SEE NOTE 1 METHOD 1010, CONDITION C: 10 OR 50 CYCLES (-65°C TO 150°C), SEE NOTE 1 METHOD 2001, Y1 AXIS ONLY: SEE NOTE 2 FOR TEST CONDITIONS METHOD 1014 CONDITION B &amp; C (RESPECTIVELY) METHOD 1015, CONDITION A, C OR D: 160 HRS @ +125°C (OR EQUIVALENT) THE FOLLOWING ELECTRICAL SUBGROUPS ARE TESTED (SEE NOTE 5) PER THE APPLICABLE DETAIL SPECIFICATION (AFTER + 25°C SCREENING, ALL LEAD FINISH "A" PRODUCT IS SOLDER DIPPED, SEE NOTE 6):</p> <ul style="list-style-type: none"> <li>• SUBGROUPS 1, 4, 7 AND/OR 9 (+25°C SCREENING PER NOTE 3).</li> <li>• SUBGROUPS 2, 5, 8 AND/OR 10 (+125°C SCREENING PER NOTE 3).</li> <li>• SUBGROUPS 3, 6, 8 AND/OR 11 (-55°C SCREENING PER NOTE 3).</li> </ul>
<p><b>QCI OPERATION GROUP A</b></p>	<p><b>QUALITY CONFORMANCE INSPECTION PER METHOD 5005, MIL-STD-883, LEVEL B: NOTE 4 PERFORMED ON EACH LOT (&amp; BURN-IN PARTIAL) PER PARA. 3.5.1:</b></p> <ul style="list-style-type: none"> <li>• SAMPLE SIZE ≥ 116/0.</li> </ul>
<p><b>GROUP B</b></p>	<p><b>PERFORMED ON EACH LOT PER TABLE IIb:</b></p> <ul style="list-style-type: none"> <li>• RESISTANCE TO SOLVENTS, METHOD 2015: SAMPLE SIZE = 3/0.</li> <li>• SOLDERABILITY, METHOD 2003 (@ 245 ± 5°C): LTPD/ACC# = 10/0 minimum.</li> <li>• BOND STRENGTH, METHOD 2011, CONDITION D: LTPD/ACC# = 15/0.</li> </ul>
<p><b>GROUP C</b></p>	<p><b>PERFORMED EVERY FOURTH QUARTER PER TABLE III, ON THE MOST COMPLEX DEVICE TYPE FROM EACH MICROCIRCUIT GROUP:</b></p> <ul style="list-style-type: none"> <li>• STEADY-STATE LIFE TEST PER METHOD 1005, COND. A, C OR D FOR 1000 HRS. @ +125°C (OR EQUIVALENT) WITH LTPD/ACC# = 5/2 MAX.</li> </ul>
<p><b>GROUP D</b></p>	<p><b>PERFORMED EVERY 26 WEEKS, PER TABLE IV, ON EACH PACKAGE FAMILY:</b></p> <ul style="list-style-type: none"> <li>• SUBG. 1: PHYSICAL DIMENSIONS (M2016) WITH LTPD/ACC# = 15/0.</li> <li>• SUBG. 2: LEAD INTEGRITY WITH SEAL ENDPOINTS (M1014, COND. B &amp; C) PER M5005, PER APPLICABLE FAMILY.</li> <li>• SUBG. 3: THERMAL SHOCK (M1011, COND B, 15 CYCLES), TEMP. CYCLE (M1010, COND. B, 100 CYCLES), MOISTURE RESISTANCE (M1004) WITH VISUAL (CRITERIA PER M1004), SEAL (M1014, COND. B &amp; C), AND ELECTRICAL (PER THE APPLICABLE DETAIL SPEC.) ENDPOINTS. LTPD/ACC# = 15/2 MAX.</li> <li>• SUBG. 4: MECH. SHOCK (M2002, COND. B), VAR. FREQ. VIBRATION (M2007, COND. A), CONSTANT ACCELERATION (M2001, SEE NOTE 2 FOR TEST COND.) WITH SEAL (M1014, COND. B &amp; C), VISUAL (CRITERIA PER M1004), AND ELECTRICAL (PER THE APPLICABLE DETAIL SPEC.) ENDPOINTS. LTPD/ACC# = 15/2 MAX.</li> <li>• SUBG. 5: SALT ATMOSPHERE (M1009, COND. A) WITH SEAL (M1014, COND. B &amp; C), VISUAL (CRITERIA PER M1009) ENDPOINTS. LTPD/ACC# = 15/0.</li> <li>• SUBG. 6: INTERNAL WATER-VAPOR CONTENT (M1018, 5K PPM MAX @ 100°C), SAMPLE SIZE = 3/0 OR 5/1.</li> <li>• SUBG. 7: ADHESION OF LEAD FINISH (M2025). LTPD/ACC# = 15/0.</li> <li>• SUBG. 8: LID TORQUE (M2024) PER APPLICABLE PACKAGE FAMILY. SAMPLE SIZE = 5/0.</li> </ul>
<p>NOTES:</p>	<ol style="list-style-type: none"> <li>1. • ALL BIPOLAR LOGIC AND MECL MEMORY PRODUCTS RECEIVE 100% VISUAL INSPECTION PER M2010, CONDITION B AND THE ALTERNATE CRITERIA SPECIFIED IN PARA. 3.3.1 OF M5004, WHICH SPECIFIES THE FOLLOWING ADDITIONAL REQUIREMENTS: 50 TEMPERATURE CYCLES (IN LIEU OF THE SPECIFIED 10 CYCLES) AND SPECIAL ELECTRICAL SCREENING TESTS AS DEFINED BY PARA. 3.3.2 (SCREENING SHALL BE PERFORMED DURING THE 100% ELECTRICAL PROBE TEST AT THE WAFER LEVEL).</li> <li>• ALL OTHER PRODUCT RECEIVE THE NORMAL M2010 VISUAL INSPECTION AND 10 TEMPERATURE CYCLES.</li> <li>2. STANDARD TEST CONDITION IS E (30KG's); HOWEVER, IF THE PACKAGE HAS AN INNER SEAL OR CAVITY PERIMETER OF 2 INCHES OR MORE IN TOTAL LENGTH, OR A PACKAGE MASS OF 5 OR MORE GRAMS, THE PRODUCT WILL BE SCREENED (OR TESTED) AT 20KG's, EXCEPT FOR THE SELECTED VLSI PACKAGES, WHICH MAY BE SCREENED (OR TESTED) AT VALUES LESS THAN 20KG's.</li> <li>3. THE ELECTRICAL SUBGROUPS TESTED SHALL BE AS SPECIFIED IN THE APPLICABLE DETAIL SPECIFICATION.</li> <li>4. THE SAMPLE SIZE INCLUDES THE ACCEPTANCE CRITERIA AS FOLLOWS: "SAMPLE SIZE = 3/0" INDICATES THAT THE SAMPLE SIZE IS 3 UNITS AND THAT THE ACCEPTANCE LEVEL IS ZERO REJECTS.</li> <li>5. ALL TESTING IS PERFORMED ON A "GO/NO GO" BASIS (OR PER APPLICABLE DETAIL SPECIFICATIONS).</li> <li>6. SOLDER DIPPING IS PERFORMED APPROXIMATELY FOUR WEEKS AFTER SEAL; HOWEVER, THE SAME DATE CODE SHALL APPLY FOR BOTH SEAL AND SOLDER. CPTO HAS IMPLEMENTED AN INTERNAL PROCEDURE TO RESOLDER AND FUNCTIONALLY TEST ANY FACTORY INVENTORY WITH DATE CODES THAT ARE 36 MONTHS OR OLDER, PRIOR TO SHIPMENT. THE RESOLDER DATE CODE SHALL BE IDENTIFIED.</li> </ol>

6

# Manufacturing, Quality & Test

Manufacturing Excellence is one of the six key "Sector Imperative" goals all Motorolans strive to achieve. Our objective is to combine advanced technological processes and talented problem-solving, goal oriented individuals to create world class products.

Our diverse product portfolio demands are satisfied by dedicated, certified fabrication facilities around the world:

Bipolar I	Mesa, AZ
Bipolar II	Mesa, AZ
Bipolar III	Mesa, AZ
Lansdale	Santa Monica, CA
MOS I	EKB, Scotland
MOS II	Austin, TX
MOS III	Austin, TX
MOS V	Mesa, AZ
MOS VI	Mesa, AZ
MOS VIII	Austin, TX

Our assembly facilities accommodate both on-shore and off-shore manufacturing and market demands. Our in-house facility in Tempe, AZ as well as our off-shore facilities in Kuala Lumpur, Malaysia and Seoul, Korea are MIL-I-38535 QML Transition Certified. Internal self-audits and inspections by DESC, Underwriters Labs and various customers are conducted regularly to ensure compliance to Motorola and Military requirements.

## Quality

Motorola was one of the first semiconductor manufacturers to realize the importance of product, process and administrative quality in reducing cost, eliminating non-value added activity, improving productivity and ultimately, satisfying our customers.

Ten and hundred-fold improvement programs were implemented and goals achieved. Average outgoing quality levels for both electrical and visual-mechanical inspection are consistently less than 50 parts per million (PPM) in the military products operation and major efforts are in place to reduce the number further.

To do this requires implementation of statistical process control (SPC) in all critical processes, continuing to reduce opportunities for error through improved manufacturing and administrative systems and implementation of continuous improvement programs by our cross-functional involvement teams. The result will be "Total Customer Satisfaction."

## Test

Motorola's Commercial Plus Technologies Operation (CPTO) utilizes state-of-the-art VLSI testers to test high-frequency, large pin count devices, (currently to 451 leads). Also, in order to increase our quality standards and to simplify our testing procedures we test most CPTO products to JAN level test programs. The benefit to our customers is obvious: the best available test programs yield the best available product for our customers.

## Manufacturing, Quality & Test (continued)

**Table 6. Certified Facilities**

MIL-I-38535 TRANSITION CERTIFIED FACILITIES					
Technology	Wafer Fab	Assembly	Burn-In	Test	QCI
Linear	Bipolar-1/Mesa, AZ	Malaysia, Korea	Malaysia, Korea, Tempe	Malaysia, Korea, Tempe	Malaysia, Korea, Tempe
LS/MECL 10K	Bipolar-2/Mesa, AZ	Malaysia	Malaysia, Tempe, AZ	Malaysia, Tempe, AZ	Malaysia, Tempe, AZ
MECL 10KH	Bipolar-2/Mesa, AZ	Malaysia	Malaysia, Tempe, AZ	Malaysia, Tempe, AZ	Malaysia, Tempe, AZ
FAST/DRAM	Bipolar-2/Mesa, AZ	Malaysia	Malaysia, Tempe, AZ	Malaysia, Tempe, AZ	Malaysia, Tempe, AZ
FACT	MOS-2/Austin, TX	Malaysia	Malaysia, Tempe, AZ	Malaysia, Tempe, AZ	Malaysia, Tempe, AZ
HCMOS Logic	MOS-2/Mesa, AZ	Malaysia	Malaysia, Tempe, AZ	Malaysia, Tempe, AZ	Malaysia, Tempe, AZ
MPU-6800	MOS-3/Austin, TX	Malaysia	Tempe, AZ	Tempe, AZ	Tempe, AZ
MPU-68000	MOS-5/Mesa, AZ	Malaysia	Tempe, AZ	Tempe, AZ	Tempe, AZ
68020/68030	MOS-8/Austin, TX	Malaysia	Tempe, AZ	Tempe, AZ	Tempe, AZ
88100/88200	MOS-8/Austin, TX	Malaysia	Tempe, AZ	Tempe, AZ	Tempe, AZ
SRAM	MOS-8/Austin, TX	Malaysia	Tempe, AZ	Tempe, AZ	Tempe, AZ
ASIC	MOS-6/Mesa, AZ	Tempe, AZ	Tempe, AZ	Tempe, AZ	Tempe, AZ

**Table 7. Process Flow Quality Ratings**

Our wide range of certified manufacturing, assembly and test areas offer our customers several different levels of screening and qualification: JAN, SMD/DESC, 883 and Commercial Plus. The table below illustrates the variety of processes available to our customers.\*

Motorola Process	Quality Level	Process Description	Quality Factor $\pi$ Q
None	S	Procured in full accordance with MIL-M-38510 Class S requirements. Class S listing on QPL-38535.	0.25
None	S-1	Procured in full compliance with the requirements of MIL-STD-975 or MIL-STD-1547 and have procuring activity specification approval.	0.75
Motorola Quasi "S"	S-2	Procured in full compliance with Motorola Document 12MRM51815A.	0.3 (EST)
MIL-M-38510	B	Procured in full accordance with MIL-M-38510 Class B Requirements. Class B listing on QPL-38535.	1.0
SMD/DESC	B-1	Fully compliant with all requirements of Paragraph 1.2.1 of MIL-STD-883 and procured to a Military or DESC Drawing or other approved documentation.	2.0
MIL-STD-883**	B-2	Fully compliant with requirements of Paragraph 1.2.1 MIL-STD-883 and procured to approved documentation including vendor's equivalent Class B requirements.	5.0
Commercial	D-1	Commercial (non-military) flow	20.0

Federal Supply Commission Manufacturing Number (FSCM#)

For reference purposes, Motorola's FSCM# is 04713

\* Reference Table 5.1.2.7-1 MIL HNBK217F

\*\* Motorola's 883 flow is identical to the SMD/DESC requirements and is fully compliant to MIL-STD-883 but may be electrically tested to a JAN/SMD/DESC drawing or to a Motorola drawing as indicated in the test program column in the 883 section. For most standard device types, the 883 version is identical to the SMD/DESC version.

6

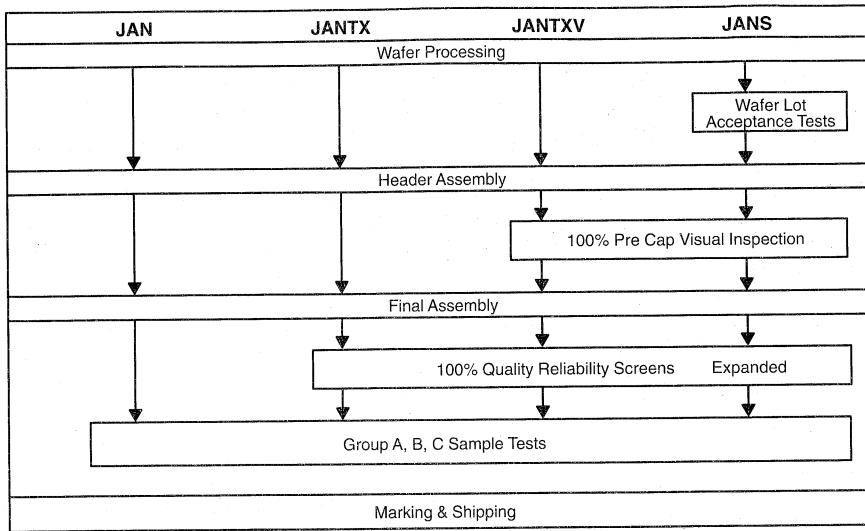

Figure 1. The MIL-S-19500 Semiconductor Process Flow

## MIL-Qualified Semiconductors

MIL-type semiconductors are high reliability components that exhibit long product life under severe operating conditions. They are specified for use in most complex systems supplied to the military market and utilized extensively to provide the required accuracy for today's missile systems and the long operational life demanded by spacecraft. To insure optimum component reliability, the

Department of Defense has established a complex system of Specifications and Standards involving all phases of manufacturing, including Facility Certification as well as Product Processing, Testing and Screening. A manufacturer of MIL-Qualified components must rigidly conform to these standards throughout all worldwide facilities.

6

## The MIL-S-19500 Specification

To ensure compliance with the requirements, the Department of Defense controls the procurement of semiconductor devices used in military equipment through a general specification, MIL-S-19500. (The latest revision of this specification is MIL-S-19500H, dated April 30, 1990.) This is maintained by the Department of the Navy but is approved for use by all departments and agencies of the Department of Defense and their military OEM subcontractors. It covers the basic requirements for the manufacture of MIL-Qualified semiconductor devices and through a series of associated "Methods documents" (MIL-STD-750) it prescribes the detailed procedures for satisfying these requirements.

Table 8. The MIL-S-19500 "Methods" Compendium

MIL-S-19491	Packaging of Semiconductors
FED-STD-209	Clean Room, Work Stations, Controlled Environments
FED-STD-H28	Screw-Thread Standards
MIL-STD-105	Sampling Procedures
MIL-STD-129	Marking for Shipment Storage
MIL-STD-750	Test Methods for Semiconductors
MIL-STD-45662	Calibration Systems Requirements

# The JAN Progression

Test methods for semiconductor devices are detailed in MIL-STD-750 which covers qualification procedures for four successively higher levels of quality assurance: JAN, JANTX, JANTXV and JANS.

The term "JAN" is a U.S. Government Certification Mark, registered by the U.S. Patent Office as number 504860, and its assignment to a specific product signifies:

- Manufacturer has complied with all requirements for the manufacture of MIL-type components.
- Product has satisfied all the applicable test requirements.
- Test data will remain on file for at least three years.
- Data will be available for on-sight review by government representatives upon request.
- That JAN data is available and may be obtained from the supplier.

A simplified production flow chart for each of the four JAN levels, including the applicable tests and screens, is shown in the illustration.

## JAN Products

JAN was the initial government classification for products requiring special reliability assurances. It signifies that the products so classified are taken from a controlled and isolated lot (or batch) of devices, and that samples from this lot have satisfactorily passed the ascribed electrical, thermal, mechanical, environmental, life and storage requirements in accordance with the associated Slash Sheet<sup>(1)</sup>. If the sample lot has passed the specified statistical criteria, the entire lot is qualified as JAN, and all devices in the lot may be marked accordingly.

## JAN Qualification Tests And Procedures

The initial set of slash-sheet-prescribed sample tests associated with the JAN qualification consists of three separate groups. These were developed to:

1. Verify conformance to electrical specifications. (Group A)
2. Assure manufacturing integrity and reliability in tactical and

**Table 9. Group A Testing**

Type of Test	Vis/Mech	Electrical					
Test Subgroups	A1	A2	A3	A4	A5	A6	A7
Test Parameters	Package: Dimensions Marking	DC Tests	Hi/Lo Temp	AC Tests	SOA Tests	Current Surge	Selected
		V <sup>(BR)</sup> CBO V <sup>(BR)</sup> CEO V <sup>(BR)</sup> EBO I <sub>CBO</sub> I <sub>EBO</sub> V <sub>BE(sat)</sub> * V <sub>CE(sat)</sub> * h <sub>FE</sub>	I <sub>CBO</sub> @ 150°C h <sub>FE</sub> @ -55°C	I <sub>hfe1</sub> h <sub>fe</sub> C <sub>obo</sub> C <sub>ibo</sub> NF*	SOA @ 25°C* Power Transistors	Diodes Rectifiers	As Specified

\* These parameters are tested under two or more operating conditions  
 (1) A slash sheet is a numbered document describing the detailed characteristics of each individual semiconductor product. It is so called because each specific document number is appended to MIL-S-19500 by a "/" (slash), e.g. MIL-S-19500/135

## JANTX Products

With increasing system complexity came the need for a reduction in the number of defective devices per lot and for a longer "Mean Time Between Failures" (MTBF). This led to the JANTX (JTX) specification and to the concept of 100% screening. This involves subjecting all devices in the proposed qualification lot to a stringent program of stress tests that must precede the sample tests associated with conventional JAN processing. These tests seek to weed out potential failures, as well as those that might pass undetected in JAN lots where only samples of the lot are investigated.

## JANTXV Products

JANTXV (JTXV) testing is essentially the same as JTX, except that the JTXV products undergo an additional 100% Precap Visual inspection. Visual screening procedures involve microscopic inspection of the semiconductor assembly, before capping the package, to uncover potential failures due to chip imperfection or imperfect die or wire bonds. While the U.S. government has qualified off-shore facilities for the assembly of JAN and JANTX devices, JANTXV products must be manufactured in the U.S. due to the visual precap inspection requirement. One exception to this is a clear-glass-encapsulated diode line which can be inspected after assembly.

## JANS Products

In the early '70s, developments in the aerospace industry dictated the accommodation of more hostile operating environments as well as extended MTBF demands. This helped drive the concept of wafer lot acceptance<sup>(2)</sup> prior to encapsulation, and spurred additional and even tighter 100% test limits after encapsulation. The resulting JANS specification reflects the most critical test sequence in effect today.

ground support applications. (Group B)

3. Provide evidence of long-term reliability under harsh environmental conditions where severe mechanical and life/environmental stresses exist (Group C).

6

Group A tests consist of visual, mechanical and electrical tests that verify "form, fit and function" of a particular group of devices. The procedure begins with the selection of a representative sample from a MIL-designated lot that has been fully processed. The sample is subjected to a test sequence that begins with a visual and mechanical inspection per MIL-STD-750 (subgroup A1), followed by a comprehensive series of electrical tests (subgroups A2 through Ax). The number of subgroups in the electrical test sequence may vary considerably, depending on the nature of the device and its potential applications. The test sequence shown depicts the procedure for a 2N3498 transistor.

The visual/mechanical inspection for the Group A tests are performed in accordance with MIL-STD-750, METHOD 2071. It consists of a sample (LTPD = 5) which is examined to determine that the devices meet the applicable materials, design, construction, marking and workmanship standards.

**Table 10. Group B Testing**

Test Subgroups	B1	B2*	B3*	B4	B5	B6*
Type of Test	Solderability	Thermal Shock	Steady State Operating Life	Decap Visual	Thermal Resistance  (when specified)	High Temp Life (non-operating)
	Resistance to Solvents	Surge	Intermittent	SEM when specified		
		Hermetic Seal	Operation Life			
		Fine Gross	Bond Strength			

**Table 11. Group C Testing**

Test Subgroups	C1	C2*	C3*	C4	C5	C6
Type of Test	Physical	Thermal Shock	Mech. Shock	Salt	Not	Steady State or Intermittent
	Dimensions	(Glass Strain)	Vibration (Variable Freq.)	Atmosphere	Applicable	Operation Life
			Constant Acceleration			
			Strength			
	Hermetic Seal					
	Moisture Resistance					

\* The tests in this subgroup are preceded and followed by electrical tests of the most susceptible parameters —  $h_{FE}$ ,  $I_{CBO}$ ,  $V_{CE(sat)}$  and  $V_{BE(sat)}$ .

This sequence includes screens that are intended to verify that the devices are mechanically sound and that they can be expected to continue to operate satisfactorily over time and under adverse operating conditions. Since a number of these screens involve stress factors that could result in ultimate performance degradation, the electrical parameters expected to be affected are tested before and after the applied screen to ascertain that the performance change remains within

A typical electrical test sequence begins with the verification of the major DC parameters of the device operating under normal (25°C) temperature conditions, Subgroup A2. Usually this is followed by testing a sample of several parameters at either high and/or low temperature limits to verify satisfactory performance over the entire temperature range for which it is specified, Subgroup A3. Then the AC (dynamic) parameters are investigated (Subgroup A4). For power transistors, the Safe Operating Area (SOA) is verified (Subgroup A5). Surge current for diodes and rectifiers is tested in Subgroup A6. Finally, Subgroup A7 provides for tests that are unique to certain products but do not fit into a general classification.

Successful completion of this test sequence provides assurance that the devices are capable of operating in accordance with their design parameters.

prescribed limits. Group B tests are run on a lot by lot basis.

Group C tests must be performed on samples from the initial lot as well as on samples from subsequent lots formed at six-month periodic intervals. These tests consist of mechanical, environmental and life tests intended to provide assurance that the devices will continue to perform reliably in long term harsh environments where severe mechanical and life/environmental stresses exist.

### JANTX, TXV, JANS Qualification — 100% Processing

Higher levels of reliability assurance require more extensive and more elaborate reliability test procedures. For these, the sample tests for JAN devices have been supplemented with the processing screens described in the table on the following page. These screens are performed immediately after lot identification, prior to the Group A, B, and C sample tests. They are applied to 100% of the devices in the lot and include

procedures developed to eliminate any marginal devices that would pass all normal operational tests but might fail under hostile environmental conditions. The most comprehensive screening procedure applies to the JANS classification which not only demands the greatest number of tests and screens after header assembly, but imposes Wafer Lot Acceptance criteria as well.

6

# Packaging and Mechanical Data

## Commercial Plus Technologies Operation Integrated Circuits Packages

CPTO products are offered in several application specific and cost effective hermetically sealed ceramic packages. Our packages conform to the mechanical requirements of MIL-STD-1835. We offer our products in the following ceramic packages: Dual In-Line package (DIL), solder seal Dual In-Line (Side Brazed DIL), ceramic FlatPack (FP or CERFLAT), Leadless Ceramic Chip Carrier (LCCC), Ceramic Leaded Chip Carrier (CLCC), several metal can packages (CAN) and Pin Grid Array (PGA).

All CPTO packages are offered in a variety of pin patterns and lead finishes. The following pages will help you determine the proper combination of package, pin count and lead finish for your specific application. For your convenience, we have also included a "Supplier Package Cross Reference" which will help you cross other suppliers packaging codes to Motorola package codes.

DIL (Dual In-Line)

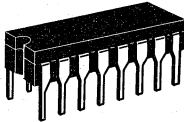

SIDEBRAZE DIL

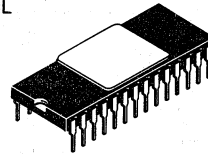

FP (Flat Pack)

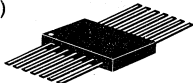

CQF (Ceramic Quad Flat)

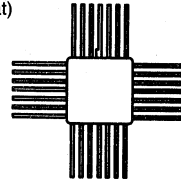

LCCC (Leadless Ceramic Chip Carrier)

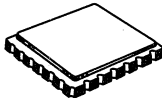

(CLCC) Ceramic Leaded Chip Carrier

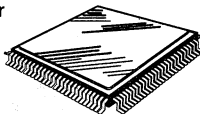

CAN (8,10 Lead)

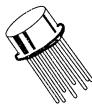

TO-5

PGA (Pin Grid Array)

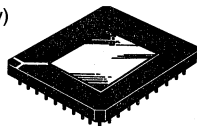

6



# Packaging and Mechanical Data: Order Quantities

## Multiple Packaging Quantities

Table 12. Multiple Packaging Quantities

Package Type	Package Description	Package	S.O.Q.	M.P.Q.	P.O.Q.
0017	14 LD Cerflat	D	1	150 Rail	1800 Box
0027	8 LD TO-5 Can	G	1	100 Bag	500 Bag
0028	10 LD TO-5 Can	I	1	100 Bag	500 Bag
0039	18 LD Cerdip	V	1	21 Rail	420 Box
0079	8 LD Cerdip	P	1	48 Rail	480 Box
0080	14 LD Cerdip	C	1	25 Rail	1500 Box
0081	16 LD Cerdip	E	1	25 Rail	1500 Box
0120	24 LD Cerdip	J	1	15 Rail	450 Box
0634	20 LD LCC	2	1	55 Rail	550 Box
0681	20 LD Cerdip	R	1	20 Rail	1000 Box
0862	16 LD Cerflat	F	1	150 Rail	1800 Box
0863	20 LD Cerflat	S	1	105 Rail	420 Box
0864	24 LD Cerflat	K	1	90 Rail	180 Box

M.P.Q. will apply to FAST, LS, MECL, CMOS and ANALOG only.

S.O.Q.  
SAMPLE ORDER QUANTITY

M.P.Q.  
MULTIPLE PACKAGING QUANTITY

P.O.Q.  
PREFERRED ORDER QUANTITY

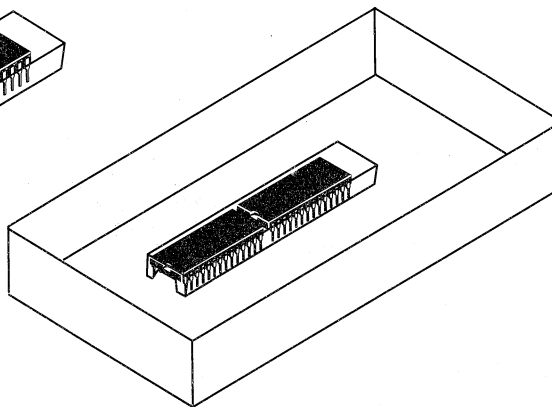
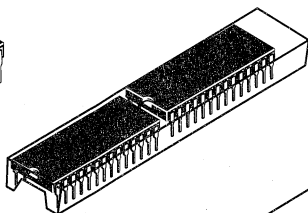
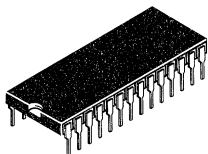

6

## Chip and Wafer Products

### GEL-PAK®

- The Motorola Commercial Plus Technologies Operation CPTO, has converted from waffle pack chip trays to GEL-PAK for all chip sales.
- Product affected: All integrated circuits, both Military and Commercial (MCC), as offered by CPTO.
- Appearance: External looks are the same. Black, Fluoroware ESD approved with a tray and lid held together by clips in a vacuum sealed EDS shielded bag.
- 2 x 2 inch for standard IC product and samples, 4 x 4 inch for larger die (i.e. Microprocessors).

### Advantages

- GEL-PAK Packaging
  - Cleans bottom side of die
  - Captures all chip dust and fragments
  - Eliminates chafing of die in cavities
  - No requirement for paper above die
  - Elimination of die sticking in cavities
  - More positive orientation
  - Eliminates spilling during handling
  - Easier access to edge of die for manual operations
  - Reduces number of tray configurations
  - 4 x 4 tray has raised edge on perimeter which will protect surface of the die in the event the tray is dropped or overturned.

Figure 2. GEL-PAK Vacuum Release Chip  
Trays

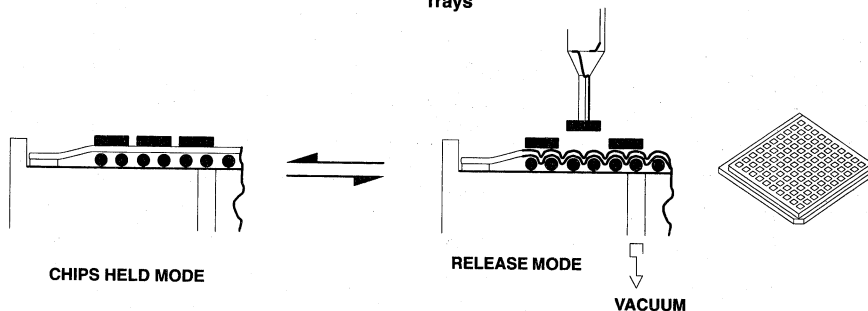

6

**Impact:** Resolves numerous quality issues associated with die handling and packaging

**Note:** User must be aware of vacuum release requirement. For further information, please contact the following:

Vichem Corp.

Phone: (408) 733-1313

CPTO Marketing

Phone: (602) 897-3769

FAX: (408) 730-1947

FAX: (602) 897-4459

DIE SALES  
(MCC)

100% visually inspected per MIL-STD-883  
method 2010, condition B.

# Chip and Wafer Products (continued)

CMOS: 14000,74HC & HCT  
 LS: 54/74LS  
 FAST: 54/74F  
 FACT: 74AC & ACT  
 ANALOG/LINEAR  
 ECLinPS: 10E/100E & 10EL/100EL  
 MECL: 10K & 10KH

MCU/MPU/RISC/DSP  
 (on a selective basis)

Note: also see Know Good Die Program

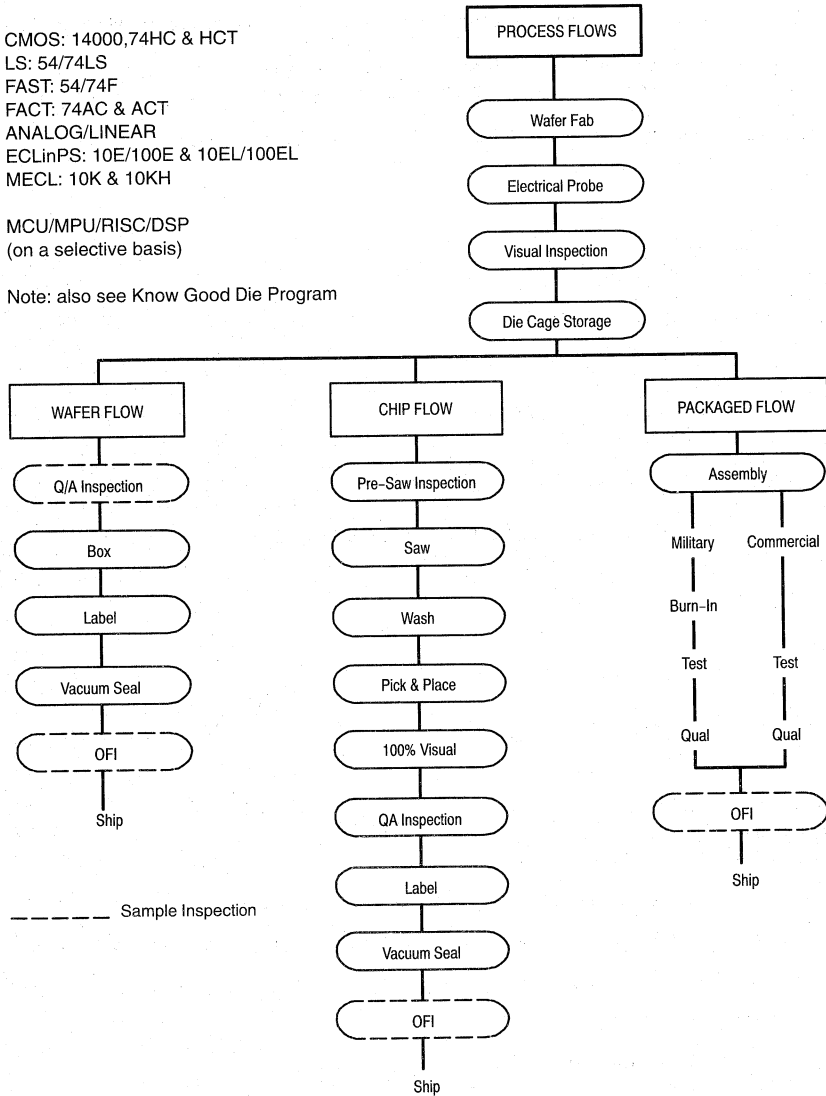

6

**FOR MIL-STD-883, METHOD 5008: LOT ACCEPTANCE TESTING**  
 MOTOROLA RECOMMENDS THESE AUTHORIZED HYBRID COMPONENT SUPPLIERS

PROCESSOR	PHONE	FAX
CHIP SUPPLY	407-298-7100	407-290-0164
ELMO SEMICONDUCTOR CORP.	818-768-7400	818-767-7038
MINCO TECHNOLOGY LABS, INC.	512-834-2022	512-837-6285
SEMI DICE, INC.	310-594-4631	310-430-5942

## Chip and Wafer Products (continued)

### Known Good Die Program

#### Introduction:

**PROBE TESTING:** Based on detailed part number. Test program is considered proprietary, however a data sheet or general spec can be provided referencing the test limits.

**VISUAL INSPECTION:**

CHIPS; 100% inspected to MIL-STD-883, Method 2010, Condition B.

WAFERS; Sample inspected, 20 random die, from various quadrants.

#### Part Number Scheme:

### KGD Part Numbering Structure

(16 Digit Maximum Field)

**TD68020A20C1**

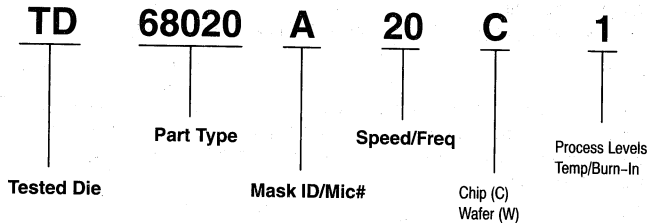

#### Part Number Prefix:

TD	Tested Die (production grade material)
ED	Engineering Sample Die (used for mechanical samples or engineering prototypes) same as ES product per Motorola SOP 3-13.
XD	Pilot Production Die (used for pilot production material and requires a letter of authorization from the customer) same as XC per Motorola SOP 3-13.
SCC	Special Process Material (material processed for specific customer)

6

## Chip and Wafer Products (continued)

### Process Levels/Test Conditions:

- |   |            |
|---|------------|
| 1 = 25 °C DC Probed (standard probe)<br>op. temp range: 0 °C to 70 °C typical yield. (See Note 1)   | GUARANTEED |
| 2 = 85 °C Special Hot Temp Probed<br>op. temp range: - 40 °C to 85 °C   | GUARANTEED |
| 3 = 25 °C DC Probed (standard probe)<br>op. temp range: - 55 °C to 125 °C <u>must be</u> processed on a QML certified line and shipped with lot summary data, detailing electrical yield. (See Notes 1 and 2) | GUARANTEED |
| 4 = 125 °C Special Hot Temp Probed<br>op. temp range: - 55 °C to 125 °C <u>need not</u> be QML certified.   | GUARANTEED |
| 5 = 125 °C Special Hot Temp Probed<br>op. temp range: - 55 °C to 125 °C <u>must be</u> processed on a QML certified line. (See Note 2)  | GUARANTEED |
| 6 = 125 °C Special Hot Temp Probed<br>op. temp range: - 55 °C to 125 °C <u>need not</u> be QML certified. (future offering)   | GUARANTEED |
| 7 = 125 °C Special Hot Temp Probed, Burn-In Screening<br>op. temp range: - 55 °C to 125 °C <u>must be</u> processed on a QML certified line. (future offering)  | GUARANTEED |

#### Notes:

1. Typical yield: 95% or greater for electrical.
2. QML certified military processed packaged part, QCI completed and production released.

### Storage And Handling:

IC's are considered sophisticated electronic devices and should be afforded full protection against ESD. The bi-metallic content of the products bond pads necessitates great care during exposure, processing and storage. Less than ideally controlled conditions can affect shelf life and it becomes the user's responsibility to accept or reject, based on the criteria and standards required to meet inspection, assembly, and test.

### Terms And Conditions:

**WARRANTY:** All devices are 100% electrical probed and are guaranteed for 6 months, if not removed from the original carriers, and stored under proper conditions.

**CANCELLATIONS:** Must be written and submitted 30 days prior to the scheduled ship date to avoid charge back for standard products. Cancellations on special material must be negotiated and charge backs will be proportionate to costs incurred.

6

### Labeling:

- Motorola (Motorola bat wing logo)
- Device # (Motorola part number)
- MOO # (process # and wafer mask ID)
- Wafer Lot #
- Assembly Lot # (locally assigned #, optional)
- Date Code (included wafer fab suffix — year and quarter, see note)
- Quantity

Note: Date Code is defined as year and work week of inspection and vacuum packaging

### Chip Carriers/Trays:

#### PRODUCTION:

GEL-PAK, 4 x 4 size, black ESD conductive.  
mesh size 16, retention level 4.

#### SAMPLE & SMALL QUANTITIES:

GEL-PAK, 2 x 2 size, black ESD conductive.  
mesh size 33, retention level 1.

### Hybrid Component Re-sellers For Motorola:

- |                         |                          |                    |
|-------------------------|--------------------------|--------------------|
| • CHIP SUPPLY           | Telephone (407) 298-7100 | Fax (407) 290-0164 |
| • ELMO SEMICONDUCTOR    | Telephone (818) 768-7400 | Fax (818) 767-7038 |
| • MINCO TECHNOLOGY LABS | Telephone (512) 834-2022 | Fax (512) 837-6285 |
| • SEMI DICE             | Telephone (310) 594-4631 | Fax (310) 430-5942 |

**2 x 2 inch tray:**

**usable surface (mils) 1350 x 1350**  
**Die placement (mils): X + Y = Die size**

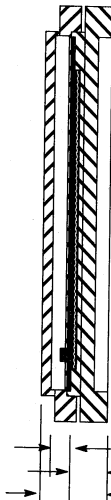
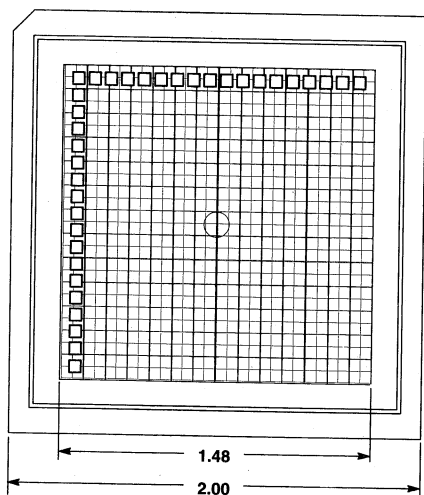

$$\frac{1350}{X + 15} \text{ (Round down value to lowest whole number) = Qty of Columns}$$

$$\frac{1350}{Y + 15} \text{ (Round down value to lowest whole number) = Qty of Rows}$$

Number of rows times number of columns = Qty per tray  
 Mesh size: 33      Retention level: 4

**4 x 4 inch tray:**

**usable surface (mils) 2800 x 2800**  
**Die placement (mils): X + Y = Die size**

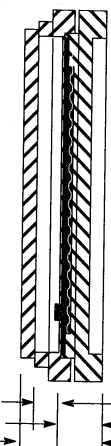
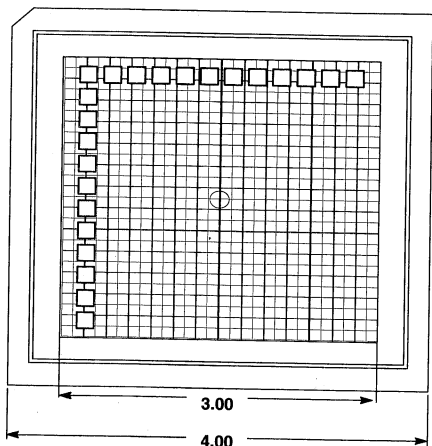

$$\frac{2800}{X + 30} \text{ (Round down value to lowest whole number) = Qty of Columns}$$

$$\frac{2800}{Y + 30} \text{ (Round down value to lowest whole number) = Qty of Rows}$$

Number of rows times number of columns = Qty per tray  
 Mesh size: 16      Retention level: 4

**Notes:**

- 1) Raised edge on perimeter of tray allows for inter-stacking of loaded trays.
- 2) Surface of GEL to top of raised edge is approx. 93 mils.

**6**

# CPTO Integrated Circuits

## In Brief . . .

During our 65-year history, we have learned to improve quality, reduce cycle time, focus on product and manufacturing leadership and create a more participative and cooperative culture among employees, customers and suppliers.

Motorola has a long history of providing competitive products to the military and aerospace industries. Motorola supplies high reliability semiconductors to these markets through the newly created Commercial Plus Technologies Operation. This new organization represents over 65 years of successful partnerships with our military and aerospace customers.

Motorola's Commercial Plus Technologies Operation produces and markets bipolar and MOS integrated circuits that perform both digital and analog functions, as well as a wide range of discrete components for standard Commercial Plus, Aerospace, and Military applications. The focus is primarily on high-volume commodity devices using proven standard technologies to provide low manufacturing costs, and on high-growth-potential products utilizing new technologies to gain a technological leadership position.

Our products are focused on Data Processing, Communications, Strategic and Tactical Weaponry, Guidance Systems, High Reliability Computers and applications in Electronic Warfare (EW) and Command, Control, Communications and Intelligence (C3I), Aerospace, and beyond commercial (Commercial Plus).

Commercial Plus Technologies Operation's charter is to provide a broad and balanced portfolio of defect-free, low-cost products IAW (In Accordance With) the QML transition certification requirements of MIL-I-38535, MIL-STD-883, and commercial plus specifications, delivered on time, with superior service to the customer. Similarly, Discrete portfolio covers a broad range of products tested to JAN, JTX, JTXV and JAN S specifications.

The Commercial Plus Technologies Operation is 100% dedicated to the manufacture and supply of standard Aerospace, Defense, and beyond commercial products, with controlled engineering, manufacturing and administrative resources. Products are manufactured, screened and tested worldwide, on lines certified to the requirements of the pertinent military specifications.

	<b>Page</b>
Analog/Telecom & Special Function . . . . .	6.2-2
Logic . . . . .	6.2-5
ECL Products . . . . .	6.2-5
100K ECLinPS Logic . . . . .	6.2-5
ECLinPS Lite . . . . .	6.2-6
MECL 10K Products . . . . .	6.2-7
MECL 10KH Products . . . . .	6.2-9
MECL III Products . . . . .	6.2-10
MECL PLL . . . . .	6.2-10
MPU Support CMOS . . . . .	6.2-11
Programmable Logic . . . . .	6.2-11
Advanced Schottky TTL (FAST) . . . . .	6.2-12
Low Power Schottky (LS) . . . . .	6.2-13
Metal Gate CMOS . . . . .	6.2-17
TTL Products . . . . .	6.2-19
Memories . . . . .	6.2-20
Bipolar Memories . . . . .	6.2-20
Specialty SRAMs . . . . .	6.2-20
BiCMOS SRAMs . . . . .	6.2-21
CMOS DRAMs . . . . .	6.2-21
High Speed CMOS III Static Memories . . . . .	6.2-22
Microprocessors . . . . .	6.2-24
8-Bit Microprocessors . . . . .	6.2-24
16- and 32-Bit Microprocessors . . . . .	6.2-25
Single Chip Microcontrollers . . . . .	6.2-26
Data Communications . . . . .	6.2-27
Digital Signal Processing (DSP) . . . . .	6.2-27
Reduced Instruction Set Computer (RISC) . . . . .	6.2-28
Application Specific Integrated Circuit (ASIC) . . . . .	6.2-28
MultiChip Modules (MCMs) . . . . .	6.2-29





# Analog/Telecom & Special Function

Table 1. Analog

JM38535/, SMD#, MIL-STD-883

Device	Pins	Description	JM38535/	SMD#	883	Package Type and Lead Finish			
						DIL	FP	CAN	LCCC
10319	24	High Speed 8-Bit A/D Flash Converter			/B	JA			
108	14	Precision Operational Amplifier			/B	CA			
	8				/B	PA		GA	
108A	14	Precision Operational Amplifier			/B	CA			
	8		10104		/B	PA		GA	
111	8	High Performance Voltage Comparator	10304			PA			
124	14	Quad Low Power Operational Amplifier	11005	7704301	/B	CA			
139	14	Quad Single Supply Comparator	11201		/B	CA			
139A	14	Quad Single Supply Comparator			/B	CA			
1488	14	Quad MDTL Line Driver [T <sub>A</sub> = 0°C to +75°C]				LTR	CA		
1489	14	Quad MDTL Line Rcvr [T <sub>A</sub> = 0°C to +75°C]				LTR	CA		
1489A	14	Quad MDTL Line Receiver [T <sub>A</sub> = 0°C to +75°C]				LTR	CA		
1508	16	8-Bit Multiplying D/A Converter			/B	EA			
1526	18	Pulse Width Modulation Control Circuit	12603	8551501	/B	VA			
1536	8	High-Voltage Operational Amplifier			/B	PA		GA	
1537	14	Dual Operational Amplifier			/B	CA			
1539	14	High Slew-Rate Operational Amplifier			/B	CA			
	8				/B	PA		GA	
1545	14	Wideband Amplifier		5962-8671201	/B	CA			
	10			5962-8671201	/B			IA	
1550	10	RF/IF Amplifier			/B			IA	
1554	10	1-Watt Power Amplifier			/B			IA	
1555	8	Timing Circuit			/B	PA		GA	
1556	14	High Performance Operational Amplifier			/B	CA			
	8				/B	PA		GA	
1558	14	Dual Operational Amplifier, Low Noise			/B	CA			
	8				/B	PA		GA	
1558S	14	High Slew-Rate Dual Operational Amplifier			/B	CA			
	8				/B	PA		GA	
1563	10	Adjustable Negative Voltage Regulator			/B			IA	
1568	14	Dual Positive/Negative ±15 Volt Tracking Reg.			/B	CA			
	10				/B			IA	
1569	10	Adjustable Positive Voltage Regulator			/B			IA	
158	8	Dual Low Power Operational Amplifier		5962-8771001	/B	PA		GA	
1590	8	Wideband Amplifier with AGC		5962-8765701	/B			GA	
1594	16	Four-Quadrant Multiplier			/B	EA			
1595	14	Four-Quadrant Multiplier			/B	CA			

TBD To Be Determined (Based on Customer Demands)  
\*Offshore Commercial Wafer Flow

6

**Table 1. Analog (continued)**

**JM38535/, SMD#, MIL-STD-883**

Device	Pins	Description	JM38535/	SMD#	883	Package Type and Lead Finish			
						DIL	FP	CAN	LCCC
1596	14	Balanced Modulator-Demodulator		5962-8857101	/B	CA			
	10			5962-8857101	/B			IA	
1709	14	General Purpose Operational Amplifier			/B	CA			
	8				/B	PA		GA	
1723	14	Adjustable Positive or Negative Voltage Reg			/B	CA			
	10				/B			IA	
1733	14	Differential Video Amplifier		8418501	/B	CA			
	10			8418501	/B			IA	
1741	14	General Purpose Operational Amplifier			/B	CA			
	8				/B	PA		GA	
1741S	8	High Slew-Rate Operational Amplifier			/B	PA		GA	
1747	14	Dual 1741 Operational Amplifier			/B	CA			
	10				/B			IA	
193	8	Dual Comparator			/B			GA	
193A	8	Dual Comparator			/B			GA	
2003A	16	Darlington Driver	14103		/B	EA			
26LS31	16	Quad RS-422 Line Driver w/ 3-State Outputs		5962-7802301	/B	EA	FA		
	20			5962-7802301					2A
26LS32	16	Quad RS-422/23 Line Rec. - 3-State Outputs		5962-7802001	/B	EA	FA		
	20			5962-7802001					2A
35035	24	DC Brushless Motor Controller			/B	LA			
35039	8	DC Brushless Motor Controller Adapter			*	PA			
35063	8	DC to DC Converter Control Circuit		5962-90757	/B	PA			
35074	14	Quad High-Perform. Single-Supply Op Amp		5962-8996901	/B	CA			
	20				/B				2A
35074A	14	Quad High-Perform. Single-Supply Op Amp		5962-8996902	/B	CA			
	20				/B				2A
35102	8	Dual Sleep Mode Op-Amp			/B	PA			
35161	8	Universal Voltage Monitor				3Q93			
35164	8	Undervoltage Lockout		5962-9231801	/B	PA			
3517	16	Continuously Variable-Slope Delta Mod/Demod		5962-8764301	/B	EA			
	20			5962-8764301	/B				2A
35174	14	Low Power Single Supply Op Amp			/B	CA			
35179	14	Quad Low Noise OpAmp			/B	CA			
35204	16	Quad 1.8 V Rail to Rail Op Amp			/B	TBD			
3523	8	Overvoltage Sensing Circuit		5962-8978001	/B	PA			

TBD To Be Determined (Based on Customer Demands)  
 \*Offshore Commercial Wafer Flow

**6**

**Table 1. Analog (continued)**

**JM38535/, SMD#, MIL-STD-883**

Device	Pins	Description	JM38535/	SMD#	883	Package Type and Lead Finish			
						DIL	FP	CAN	LCCC
35304	14	Quad 1.8 V Rail to Rail Sleep Mode Op Amp			/B	TBD			
431	8	Programmable Precision References	14801	8410901	/B	PA			

TBD To Be Determined (Based on Customer Demands)  
 \*Offshore Commercial Wafer Flow

**Table 2. Telecom & Special Functions**

**JM38535/, SMD#, MIL-STD-883**

Device	Pins	Description	JM38535/	SMD#	883	Package Type and Lead Finish			
						DIL	FP	CAN	LCCC
55107	14	Dual Line Receiver	10401		/B	CA			
56156	112	16-Bit General Purpose RAM DSP with $\Sigma\Delta$ Codec							TBD
56ADC16	20	16-Bit $\Sigma\Delta$ A/D			/B	1Q94			
6875A	16	6800 MPU Clock Generator/Driver			/B	EA			
145146-2	20	PLL 4-Bit Data Bus Programmable			/B	4Q93			
145406-2	16	RS232/V.28 Driver Receiver			/B	EA			
145407-2	20	RS232D/V.28 Driver Receiver (5.0 Volt only)			/B	4Q93			
145151-2	28	PLL Parallel Programmable			/B	XA			
145152-2	28	PLL Parallel Programmable			/B	XA			
145155-2	18	PLL Serial Input			/B	VA			
145156-2	20	PLL Serial Input			/B	RA			
145157-2	16	PLL Serial Input			/B	EA			
145158-2	16	PLL Serial Input			/B	EA			
145190		1.1 GHz UHF PLL Frequency Synthesizer Low Voltage			/B	TBD			
145191		1.1 GHz UHF PLL Frequency Synthesizer Low Voltage			/B	TBD			
145192		1.1 GHz UHF PLL Frequency Synthesizer Low Voltage			/B	TBD			

TBD To Be Determined (Based on Customer Demands)

**6**

# Logic Products

## ECL Products

Table 3. 100K Emitter Coupled Logic in Picoseconds ( **ECLPS** ) Logic  
JM38535/, SMD#, MIL-STD-883

Device	Pins	Description	JM38535/	SMD#	883	Package Type and Lead Finish			
						PGA	QFP	CAN	LCCC
10E416	28	8-Bit Synchronous Binary Up Counter		5962-9309801	/B	TBD	YA		
10E501	28	Quad 4-Input OR/NOR Gate		5962-9309901	/B	TBD	YA		
10E504	28	Quint 2-Input AND/NAND Gate		5962-9310001	/B	TBD	YA		
10E507	28	Quint 2-Input XOR/XNOR Gate		5962-9310101	/B	TBD	YA		
10E511	28	1:9 Differential Clock Driver, Low Skew, Enable, V <sub>BB</sub> , Differential Outputs		5962-9232701	/B	TBD	YA		
10E516	28	Quint Differential Line Receiver		5962-9234301	/B	TBD	YA		
10E531	28	4-Bit D Flip-Flop		5962-9310201	/B	TBD	YA		
10E541	28	8-Bit Shift Register		5962-9310301	/B	TBD	YA		
10E551	28	6-Bit D Register		5962-9310401	/B	TBD	YA		
10E595	28	Programmable Delay Chip		Planned	/B	TBD	1Q94		
10E851	28	6-Bit D Register, Diff. Data Clock Inputs		5962-9234201	/B	TBD	YA		
100E416	28	8-Bit Synchronous Binary Up Counter		5962-9309802	/B	TBD	YA		
100E501	28	Quad 4-Input OR/NOR Gate		5962-9309902	/B	TBD	YA		
100E504	28	Quint 2-Input AND/NAND Gate		5962-9310002	/B	TBD	YA		
100E507	28	Quint 2-Input XOR/XNOR Gate		5962-9310102	/B	TBD	YA		
100E511	28	1:9 Differential Clock Driver Low Skew, Enable, V <sub>BB</sub> , Differential Output		5962-9232702	/B	TBD	YA		
100E516	28	Quint Differential Line Receiver		5962-9234302	/B	TBD	YA		
100E531	28	4-Bit D Flip-Flop		5962-9310202	/B	TBD	YA		
100E541	28	8-Bit Shift Register		5962-9310302	/B	TBD	YA		
100E551	28	6-Bit D Register		5962-9310402	/B	TBD	YA		
100E595	28	Programmable Delay Chip		Planned	/B	TBD	1Q94		
100E851	28	6-Bit D Register, Differential Data & Clk Inputs V <sub>BB</sub> , Common Reset, Single Ended Output		5962-9234202	/B	TBD	YA		

TBD: To Be Determined (Based on Customer Demands), other devices not listed can be ordered with NRE, contact factory

6

**Table 4. ECLinPS Lite**

**JM38535/ SMD#, MIL-STD-883**

Device	Pins	Description	JM38535/	SMD#	883	Package Type and Lead Finish			
						PGA	QFP	CAN	LCCC
10EL15	16	1:4 Clock Distribution Chip			/B				TBD
10ELT20	8	TTL to PECL Translator			/B				TBD
10ELT21	8	PECL to TTL Translator			/B				TBD
10ELT22	8	Dual TTL to PECL Translator			/B				TBD
10ELT23	8	Dual PECL to TTL Translator			/B				TBD
10ELT24	8	TTL to ECL Translator			/B				2Q94
10ELT25	8	ECL to TTL Translator			/B				TBD
10ELT26	8	1:2 Fanout PECL to TTL Translator			/B				TBD
10ELT28	8	PECL to TTL & TTL to ECL Translator			/B				TBD
10ELT34	16	+ 2, 4, 8 Differential Clock Driver			/B				TBD
10ELT35	8	J-K Flip-Flop			/B				TBD
10ELT57	16	4:1 Differential Multiplexer			/B				TBD
100EL01	8	4-Input OR/NOR Gate			/B				TBD
100EL04	8	2-Input AND/NAND Gate			/B				TBD
100EL05	8	2-Input Differential AND/NAND Gate			/B				TBD
100EL07	8	2-Input XOR/XNOR Gate			/B				2Q94
100EL11	8	1:2 Differential Clock Driver			/B				TBD
100EL12	8	Driver			/B				TBD
100EL15	16	1:4 Clock Distribution Chip			/B				TBD
100EL16	8	Differential Receiver			/B				TBD
100ELT20	8	TTL to PECL Translator			/B				TBD
100ELT21	8	PECL to TTL Translator			/B				TBD
100ELT22	8	Dual TTL to PECL Translator			/B				TBD
100ELT23	8	Dual PECL to TTL Translator			/B				TBD
100ELT24	8	TTL to ECL Translator			/B				TBD
100ELT25	8	ECL to TTL Translator			/B				TBD
100ELT26	8	1:2 Fanout PECL to TTL Translator			/B				TBD
100ELT28	8	PECL to TTL & TTL to ECL Translator			/B				TBD
100EL31	8	D Flip-Flop with Set and Reset			/B				TBD
100EL32	8	+ 2 Divider			/B				TBD
100EL33	8	+ 4 Divider			/B				TBD
100EL34	16	+ 2, 4, 8 Differential Clock Driver			/B				TBD
100EL35	8	J-K Flip-Flop			/B				TBD
100EL51	8	Differential Clock D Flip-Flop			/B				2Q94
100EL52	8	Differential Data & Clock D Flip-Flop			/B				TBD
100EL57	16	4:1 Differential Multiplexer			/B				TBD
100EL58	8	2:1 Multiplexer			/B				TBD

TBD: To Be Determined (Based on Customer Demands), other devices not listed can be ordered with NRE, contact factory

6

**Table 5. MECL 10K (Motorola Emitter Coupled Logic)**

**JM38535/, SMD#, MIL-STD-883**

Device	Pins	Description	JM38535/	SMD#	883	Package Type and Lead Finish			
						DIL	FP	CAN	LCCC
10500	16	Quad 2-Input NOR Gate with Strobe			/B	EA	FA		2A
10501	16	Quad OR/NOR Gate	06001		/B	EA	FA		2A
10502	16	Quad 2-Input NOR Gate	06002		/B	EA	FA		2A
10503	16	Quad 2-Input OR Gate			/B	EA	FA		2A
10504	16	Quad 2-Input AND Gate	06201		/B	EA	FA		2A
10505	16	Triple 2-3-2-Input OR/NOR Gate	06003		/B	EA	FA		2A
10506	16	Triple 4-3-3-Input NOR Gate	06004		/B	EA	FA		2A
10507	16	Triple 2-Input Exclusive OR Exclusive NOR Gate	06005		/B	EA	FA		2A
10509	16	Dual 4-5-Input OR/NOR Gate	06006		/B	EA	FA		2A
10513	16	Quad Exclusive OR Gate			/B	EA	FA		2A
10514	16	Triple Line Receiver			/B	EA	FA		2A
10515	16	Quad Line Receiver			/B	EA	FA		2A
10516	16	Triple Line Receiver		7800901	/B	EA	FA		2A
10517	16	Dual 2-Wide 2-3-Input OR-AND/OR-AND-INVERT Gate			/B	EA	FA		2A
10518	16	Dual 2-Wide 3-Input OR-AND Gate			/B	EA	FA		2A
10519	16	4-Wide 4-3-3-Input OR-AND Gate			/B	EA	FA		2A
10521	16	4-Wide OR-AND/OR-AND-INVERT Gate		5962-8857701	/B	EA	FA		2A
10523	16	Triple 4-3-3-Input Bus Driver			/B	EA	FA		2A
10524	16	Quad TTL-to-MECL Translator	06301		/B	EA	FA		2A
10525	16	Quad MECL-to-TTL Translator	06302		/B	EA	FA		2A
10530	16	Dual Latch			/B	EA	FA		2A
10531	16	Dual Type D Master-Slave Flip-Flop	06101		/B	EA	FA		2A
10533	16	Quad Latch			/B	EA	FA		2A
10535	16	Dual J-K Master-Slave Flip-Flop	06104		/B	EA	FA		2A
10536	16	Universal Hexadecimal Counter			/B	EA	FA		2A
10537	16	Universal Decade Counter			/B	EA	FA		2A
10538	16	Bi-Quinary Counter			/B	EA	FA		2A
10539	16	32 x 8-Bit PROM			/B	EA	FA		2A
10541	16	4-Bit Universal Shift Register		5962-8855701	/B	EA	FA		2A
10545	16	64-Bit Register File (RAM)		5962-8856001	/B	EA	FA		2A
10549	16	256 x 4-Bit PROM			/B	EA	FA		2A
10552	16	256 x 1-Bit RAM			/B	EA	FA		2A
10553	16	Quad Latch (Negative Clock)			/B	EA	FA		2A
10558	16	Quad 2-Input Multiplexer (Non-inverting)		5962-8779201	/B	EA	FA		2A
10560	16	12-Bit Parity Generator-Checker			/B	EA	FA		2A
10561	16	Binary to 1-8-Line Decoder (Low)			/B	EA	FA		2A
10562	16	Binary to 1-8-Line Decoder (High)			/B	EA	FA		2A

6

**Table 5. MECL 10K (Motorola Emitter Coupled Logic) (continued)**

**JM38535/, SMD#, MIL-STD-883**

Device	Pins	Description	JM38535/	SMD#	883	Package Type and Lead Finish			
						DIL	FP	CAN	LCCC
10563	16	Error Detection and Correction Circuit (IBM Pattern)			/B	EA	FA		2A
10564	16	8-Line Multiplexer		5962-8852701	/B	EA	FA		2A
10565	16	8-Input Priority Encoder		5962-9056101	/B	EA	FA		2A
10566	16	5-Bit Magnitude Comparator			/B	EA	FA		2A
10568	16	Quad Latch (Common Clock)			/B	EA	FA		2A
10570	16	9+2-Bit Parity Generator-Checker			/B	EA	FA		2A
10571	16	Dual Binary to 1-4-Decoder (Low)			/B	EA	FA		2A
10572	16	Dual Binary to 1-4-Decoder (High)			/B	EA	FA		2A
10573	16	Quad 2-Input Multiplexer/Latch			/B	EA	FA		2A
10574	16	Dual 4-to-1 Multiplexer			/B	EA	FA		2A
10575	16	Quint Latch			/B	EA	FA		2A
10576	16	Hex D Master-slave Flip-Flop	06103		/B	EA	FA		2A
10578	16	Binary Counter			/B	EA	FA		2A
10579	16	Look-ahead Carry Block			/B	EA	FA		2A
10580	16	Dual 2-Bit High-Speed Adder/Subtractor			/B	EA	FA		2A
10581	24	4-Bit Arithmetic Logic Unit/Function Generator			/B	JA	KA		N/A
10582	16	2-Bit Arithmetic Logic Unit/Function Generator			/B	EA	FA		2A
10586	16	Hex D Master-Slave Flip-Flop With Reset		5962-8779301	/B	EA	FA		2A
10590	16	Quad IBM (MST)-to-MECL Translator			/B	EA	FA		2A
10591	16	Hex MECL-to-IBM (MST) Translator			/B	EA	FA		2A
10592	16	Quad Bus Driver		5962-9311101	/B	EA	FA		2A
10593	16	Error Correcting/Detecting Circuit			/B	EA	FA		2A
10595	16	Hex Inverter/Buffer			/B	EA	FA		2A
10597	16	Hex AND Gate	06202		/B	EA	FA		2A
10598	16	Monostable Multivibrator		5962-8777301	/B	EA	FA		2A
10610	16	High Speed Dual 3-Input/3-Output OR Gate			/B	EA	FA		2A
10611	16	High Speed Dual 3-Input/3-Output NOR Gate			/B	EA	FA		2A
10612	16	High Speed Dual 3-Input/3-Output OR/NOR Gate		5962-8775001	/B	EA	FA		2A
10616	16	High Speed Triple Line Receiver			/B	EA	FA		2A
10631	16	High Speed Dual D Master-Slave Flip-Flop	06102		/B	EA	FA		2A

**6**

Table 6. MECL 10KH

JM38535/, SMD#, MIL-STD-883

Device	Pins	Description	JM38535/	SMD#	883	Package Type and Lead Finish			
						DIL	FP	CAN	LCCC
10H416	16	Binary Counter		5962-8759001	/B	EA	FA		2A
10H500	16	Quad 2-Input NOR w/Strobe			/B	EA			
10H501	16	Quad OR/NOR Gate		5962-8750301	/B	EA	FA		2A
10H502	16	Quad 2-Input NOR Gate		5962-8755701	/B	EA	FA		2A
10H503	16	Quad 2-Input OR Gate		5962-8756501	/B	EA	FA		2A
10H504	16	Quad 2-Input AND Gate		5962-8750401	/B	EA	FA		2A
10H505	16	Triple 2-3-2-Input OR/NOR Gate		5962-8750701	/B	EA	FA		2A
10H506	16	Triple 4-3-3-Input NOR Gate		5962-8756401	/B	EA	FA		2A
10H507	16	Triple 2-Input/Exclusive NOR Gate		5962-8772701	/B	EA	FA		2A
10H509	16	Dual 4-5-Input OR/NOR Gate		5962-8985601	/B	EA	FA		2A
10H513	16	Quad Exclusive OR Gate		5962-8755801	/B	EA	FA		2A
10H515	16	Quad Line Receiver		5962-8750101	/B	EA	FA		2A
10H516	16	Triple Line Receiver		5962-8750201	/B	EA	FA		2A
10H517	16	Dual 2-Wide 2-3-Input OR-AND/OR-AND-INVERT Gate			/B	EA	FA		2A
10H518	16	Dual 2-Wide 3-Input OR/AND Gate		5962-8755901	/B	EA	FA		2A
10H519	16	4-Wide 4-3-3-Input OR-AND Gate		5962-8772801	/B	EA	FA		2A
10H521	16	4-Wide OR-AND/OR-AND INVERT Gate		5962-8773001	/B	EA	FA		2A
10H524	16	Quad TTL-to-MECL Translator		5962-8756001	/B	EA	FA		2A
10H525	16	Quad MECL-to-TTL Translator		5962-8750801	/B	EA	FA		2A
10H531	16	Dual D Master Slave Flip-Flop		5962-8756101	/B	EA	FA		2A
10H535	16	Dual J-K Master Slave Flip-Flop		5962-8750501	/B	EA	FA		2A
10H536	16	Universal Hexadecimal Counter		5962-8700101	/B	EA	FA		2A
10H541	16	4-Bit Universal Shift Register		5962-8751101	/B	EA	FA		2A
10H558	16	Quad 2-Input Multiplexer (Non-inverting)		5962-8756601	/B	EA	FA		2A
10H560	16	12-Bit Parity Generator-Checker		5962-8756201	/B	EA	FA		2A
10H561	16	Binary to 1-8-Line Decoder (Low)		5962-8756701	/B	EA	FA		2A
10H562	16	Binary 1-8-Line Decoder (High)			/B	EA	FA		2A
10H564	16	8-Line Multiplexer		5962-8772901	/B	EA	FA		2A
10H571	16	Dual Binary to 1-4-Line Decoder (Low)		5962-8756801	/B	EA	FA		2A
10H574	16	Dual 4-1-Multiplexer		5962-8750601	/B	EA	FA		2A
10H576	16	Hex D Master-Slave Flip-Flop		5962-8751201	/B	EA	FA		2A
10H581	24	4-Bit Arithmetic Logic Unit/Function Generator			/B	JA	KA		N/A
10H586	16	Hex D Master-Slave Flip-Flop w/Common Reset		5962-8756301	/B	EA	FA		2A
10H588	16	Hex Buffer w/Enable		5962-8750901	/B	EA	FA		2A
10H589	16	Hex Inverter w/Enable		5962-8751001	/B	EA	FA		2A
10H609	16	Dual 4-5-Input OR/NOR Gate		5962-8756901	/B	EA	FA		2A
10H610	16	High Speed Dual 3-Input/3-Output OR Gate		5962-8754101	/B	EA	FA		2A

TBD To Be Determined (Based on Customer Demands)

6



**Table 6. MECL 10KH (continued)**

**JM38535/, SMD#, MIL-STD-883**

Device	Pins	Description	JM38535/	SMD#	883	Package Type and Lead Finish			
						DIL	FP	CAN	LCCC
10H750	16	ECL-to-TTL Translator (Quad), Single Power Supply (-5.2 V or +5.0 V)		5962-9058801	/B	EA	FA		2A
10H751	20	Quad TTL/NMOS to MECL Translator			/B	RA	4Q93		2A
10H1042	28	68030/040 ECL/TTL Clock Driver		5962-9207501	/B	TBD	YA		TBD
100H1042	28	68030/040 ECL/TTL Clock Driver		5962-9207502	/B	TBD	YA		TBD

TBD To Be Determined (Based on Customer Demands)

**Table 7. MECL III**

**JM38535/, SMD#, MIL-STD-883**

Device	Pins	Description	JM38535/	SMD#	883	Package Type and Lead Finish			
						DIL	FP	CAN	LCCC
1648M	14	Voltage Controlled Oscillator, [T <sub>A</sub> = -55°C to +125°C]		5962-8977801	/B	CA	DA		2A
1650	16	Dual A/D Converter [T <sub>A</sub> = -30°C to +85°C]			LTR	EA	FA		
1651	16	Dual A/D Converter [T <sub>A</sub> = -30°C to +85°C]			LTR	EA	FA		
1654	16	Binary Counter [T <sub>A</sub> = -30°C to +85°C]			LTR	EA			
1660	16	Dual 4-Input Gate [T <sub>A</sub> = -30°C to +85°C]			LTR	EA	FA		
1662	16	Quad 2-Input NOR Gate [T <sub>A</sub> = -30°C to +85°C]			LTR	EA	FA		
1664	16	Quad 2-Input OR Gate [T <sub>A</sub> = -30°C to +85°C]			LTR	EA	FA		
1670	16	Master-Slave Flip-Flop [T <sub>A</sub> = -30°C to +85°C]			LTR	EA	FA		
1672	16	Triple 2-Input Exclusive OR Gate, [T <sub>A</sub> = -30°C to +85°C]			LTR	EA	FA		
1678	16	Bi-Quinary Counter [T <sub>A</sub> = -30°C to +85°C]			LTR	EA			
1690	16	UHF Prescaler D Flip-Flop [T <sub>A</sub> = -30°C to +85°C]			LTR	EA	FA		
1692	16	Quad Line Receiver [T <sub>A</sub> = -30°C to +85°C]			LTR	EA	FA		

**6**

**Table 8. MECL Phase-Locked-Loop (PLL)**

**JM38535/, SMD#, MIL-STD-883**

Device	Pins	Description	JM38535/	SMD#	883	Package Type and Lead Finish			
						DIL	FP	CAN	LCCC
12502	14	Analog Mixer Double Balanced			/B	CA			
12509	16	Two-Modulus-5/+6, 600 MHz Typical		5962-8774801	/B	EA			
12511	16	Two-Modulus-8/+9, 600 MHz Typical		5962-8774301	/B	EA			
12513	16	Two-Modulus-10/+2, 600 MHz Typical		5962-8774901	/B	EA			
12514	16	Counter-Control Logic		5962-8775101	/B	EA			
12515	8	Low Power Two-Modulus Prescaler			/B	PA			
12540	14	Phase-Frequency Detector		5962-8775201	/B	CA			
12561	16	Crystal Oscillator (2-20 MHz)			/B	EA			

## MPU Support CMOS

Table 9. MPU Support CMOS

JM38535/, SMD#, MIL-STD-883

Device	Pins	Description	JM38535/	SMD#	883	Package Type and Lead Finish				
						DIL	FP	PGA	CQF	CLCC
88913	14	Low Skew Clock Driver, Reset			/B	CA	1Q94			
88914	14	Low Skew Clock Driver, Reset			/B	CA	1Q94			
88915-55	28	Low Skew PLL Clock Driver			/B			4Q93	YA	
88915T-70	28	Low Skew PLL Clock Driver		Planned				1Q94	1Q94	
88916-80	20	Low Skew PLL Clock Driver			/B	1Q94	1Q94			
88920-50	20	Low Skew PLL Clock Driver		Planned		4Q93	1Q94			
68150	68	Dynamic R/W Bus Sizer		Planned						2Q94

## Programmable Logic

Table 10. Programmable Logic

JM38535/, SMD#, MIL-STD-883

Device	Pins	Description	JM38535/	SMD#	883	Package Type and Lead Finish			
						DIL	FP	CQF	LCCC
22V10XXX	24	EECMOS 22V10 PLD		Planned		2Q94	2Q94		
22V10XXX	28	EECMOS 22V10 PLD		Planned					2Q94

# Advanced Schottky TTL (FAST)

Table 11. Bipolar Logic

JM38535/, SMD#, MIL-STD-883

Device	Pins	Description	JM38535/	SMD#	883	Package Type and Lead Finish			
						DIL	FP	CAN	LCCC
54F00	14	Quad 2-Input NAND Gate	33001		/B	CA	DA		2A
54F02	14	Quad 2-Input NOR Gate	33301		/B	CA	DA		2A
54F04	14	Hex Inverter	33002		/B	CA	DA		2A
54F08	14	Quad 2-Input AND Gate	34001		/B	CA	DA		2A
54F10	14	Triple 3-Input NAND Gate	33003		/B	CA	DA		2A
54F109	16	Dual JK Flip-Flop with Preset	34102		/B	EA	FA		2A
54F11	14	Triple 3-Input AND Gate	34002		/B	CA	DA		2A
54F125	14	Quad Buffer, 3-State, Enable-LO			/B	CA	DA		2A
54F126	14	Quad Buffer, 3-State, Enable-HI			/B	CA	DA		2A
54F13	14	Dual 4-Input NAND Schmitt Trigger			/B	CA	DA		2A
54F132	14	Quad 2-Input NAND Schmitt Trigger			/B	CA	DA		2A
54F138	16	1-of-8-Decoder/Demultiplexer	33701		/B	EA	FA		2A
54F139	16	Dual 1-of-4-Decoder/Demultiplexer	33702		/B	EA	FA		2A
54F14	14	Hex Inverter Schmitt Trigger		5962-8875201	/B	CA	DA		2A
54F151	16	8-Input Multiplexer	33901		/B	EA	FA		2A
54F153	16	Dual 4-Input Multiplexer	33902		/B	EA	FA		2A
54F157A	16	Quad 2-Input Multiplexer	33903		/B	EA	FA		2A
54F158A	16	Quad 2-Input Multiplexer, Inverting	33904		/B	EA	FA		2A
54F161A	16	4-Bit Binary Counter, Asynchronous Reset	34301		/B	EA	FA		2A
54F174	16	Hex D Flip-Flop	34107		/B	EA	FA		2A
54F175	16	Quad D Flip-Flop	34104		/B	EA	FA		2A
54F182	16	Look-Ahead Carry Generator	33802		/B	EA	FA		2A
54F194	16	Universal Shift Register	33601		/B	EA	FA		2A
54F20	14	Dual 4-Input NAND Gate	33004		/B	CA	DA		2A
54F240	20	Octal Buffer/Line Driver/Inverting/3-State	33201		/B	RA	SA		2A
54F241	20	Octal Buffer/Line Driver, 3-State	33202	5962-8687401	/B	RA	SA		2A
54F242	14	Quad Non-Inverting Bus Transceiver/3-State	34801		/B	CA	DA		2A
54F243	14	Quad Bus Transceiver/Non-Inverting/3-State	34802	5962-8683401	/B	CA	DA		2A
54F244	20	Quad Buffer Driver/Non-Inverting/3-State	33203		/B	RA	SA		2A
54F245	20	Octal Bus Transceiver	34803	8551101	/B	RA	SA		2A
54F251	16	8-Input Multiplexer/3-State			/B	EA	FA		2A
54F253	16	Dual 4-Input Multiplexer/3-State	33908		/B	EA	FA		2A
54F257	16	Quad 2-Input Multiplexer/3-State			/B	EA	FA		2A
54F258	16	Quad 2-Input Multiplexer/Inverting/3-State			/B	EA	FA		2A
54F280	14	9-Bit Odd/Even Parity Generator/Checker	34901		/B	CA	DA		2A
54F283	16	4-Bit Full Adder	34201		/B	EA	FA		2A
54F32	14	Quad 2-Input OR Gate	33501		/B	CA	DA		2A

6

**Table 11. Bipolar Logic (continued)**

**JM38535/ SMD#, MIL-STD-883**

Device	Pins	Description	JM38535/	SMD#	883	Package Type and Lead Finish			
						DIL	FP	CAN	LCCC
54F352	16	Dual 4-Input Multiplexer	33909		/B	EA	FA		2A
54F353	16	Dual 4-Input Multiplexer/3-State	33910		/B	EA	FA		2A
54F373	20	Octal Transparent Latch/3-State	34601		/B	RA	SA		2A
54F374	20	Octal D Flip-Flop/3-State	34105		/B	RA	SA		2A
54F378	16	Hex Parallel D Register with Enable	34108	5962-8855501	/B	EA	FA		2A
54F379	16	Quad Parallel Register with Enable	34109		/B	EA	FA		2A
54F381	20	4-Bit ALU	33803	5962-8671001	/B	RA	SA		2A
54F382	20	4-Bit ALU	33804		/B	RA	SA		2A
54F398	20	Quad 2-Port Register	35001		/B	RA	SA		2A
54F399	16	4-Bit Register with Non-Inverting Outputs	35002		/B	EA	FA		2A
54F521	20	Octal Comparator			/B	RA	SA		2A
54F533	20	Octal Transparent Latch/3-State	34602		/B	RA	SA		2A
54F534	20	Octal D-Type Flip-Flop/3-State	34106		/B	RA	SA		2A
54F64	14	4-2-3-2-Input AND-OR-INVERT Gate	33401		/B	CA	DA		2A
54F74	14	Dual D Flip-Flop	34101		/B	CA	DA		2A
54F803	14	Clock Driver with Matched Propagation Delays			/B	CA	DA		2A
54F86	14	Quad 2-Input Exclusive OR Gate	34501		/B	CA	DA		2A

## Low Power Schottky (LS)

**Table 12. Bipolar Logic**

**JM38535, SMD#, MIL-STD-883**

Device	Pins	Description	JM38535/	SMD#	883	Package Type and Lead Finish			
						DIL	FP	CAN	LCCC
54LS00	14	Quad 2-Input NAND Gate	30001		/B	CA	DA		2A
54LS02	14	Quad 2-Input NOR Gate	30301		/B	CA	DA		2A
54LS03	14	Quad 2-Input NAND Gate, Open-Collector	30002		/B	CA			2A
54LS04	14	Hex Inverter	30003		/B	CA	DA		2A
54LS05	14	Hex Inverter, Open-Collector	30004		/B	CA			2A
54LS08	14	Quad 2-Input AND Gate	31004		/B	CA	DA		2A
54LS09	14	Quad 2-Input AND Gate, Open-Collector	31005		/B	CA	DA		2A
54LS10	14	Triple 3-Input NAND Gate	30005	8001901	/B	CA	DA		2A
54LS107A	14	Dual JK Flip-Flop with Clear	30108		/B	CA			2A
54LS109A	16	Dual JK Flip-Flop with Preset	30109		/B	EA	FA		
54LS11	14	Triple 3-Input Positive AND Gate	31001		/B	CA	DA		2A
54LS112A	16	Dual JK Edge-Triggered Flip-Flop	30103		/B	EA	FA		2A

**6**

Table 12. Bipolar Logic (continued)

JM38535, SMD#, MIL-STD-883

Device	Pins	Description	JM38535/	SMD#	883	Package Type and Lead Finish			
						DIL	FP	CAN	LCCC
54LS113A	14	Dual JK Edge-Triggered Flip-Flop	30104		/B	CA CA	DA		
54LS114A	14	Dual JK Edge-Triggered Flip-Flop	30105			CA			
54LS12	14	Triple 3-Input NAND Gate, Open-Collector	30006			CA	DA		
54LS122	14	Retriggerable Monostable Multivibrator	31403			CA	DA		
				7600301	/B	CA			
54LS123	16	Dual Retriggerable Monostable Multivibrator	31401	7603901	/B	EA	FA		2A
54LS125A	14	Quad Buffer, Low Enable, 3-State	32301			CA	DA		2A
					/B	CA			2A
54LS126A	14	Quad Buffer, High Enable, 3-State	32302		/B	CA			
54LS13	14	Dual 4-Input Schmitt Trigger	31301			CA			
54LS132	14	Quad 2-Input Schmitt Trigger	31303			CA	DA		
				7600401	/B	CA			
54LS133	16	13-Input NAND Gate			/B	EA			
54LS138	16	1-of-8-Decoder/Multiplexer	30701	7600501	/B	EA	FA		2A
54LS139	16	Dual 1-of-4-Decoder/Multiplexer	30702	7600701	/B	EA	FA		2A
54LS14	14	Hex Schmitt Trigger	31302			CA	DA		2A
					/B	CA			2A
54LS15	14	Triple 3-Input AND Gate	31002			CA			
54LS151	16	8-Input Multiplexer	30901	7601001		EA	FA		2A
					/B	EA	FA		2A
54LS153	16	Dual Input Multiplexer	30902			EA	FA		2A
				7601101	/B	EA			
54LS155	16	Dual 1-to-4-Decoder	32601		/B	EA			
54LS156	16	Dual 1-to-4-Decoder, Open Collector			/B	EA			
54LS157	16	Quad 2-Input Multiplexer, Non-Inverting	30903	7600201	/B	EA	FA		2A
54LS158	16	Quad 2-Input Multiplexer, Inverting	30904	7603301	/B	EA			
54LS160A	16	BCD Decade Counter, Asynchronous Reset	31503	7700901	/B	EA			
54LS161A	16	4-Bit Binary Counter, Asynchronous Reset	31504		/B	EA	FA		2A
				7600801		EA			
54LS162A	16	BCD Decade Counter, Synchronous Reset	31511			EA			
54LS163A	16	4-Bit Binary Counter, Synchronous Reset	31512			EA	FA		
				7603401	/B	EA	FA		2A
54LS164	14	8-Bit Serial-In/Parallel-Out Shift Register	30605			CA	DA		2A
					/B	CA			2A
54LS165	16	8-Bit Parallel-In/Serial-Out Shift Register	30608			EA	FA		2A
					/B	EA			2A
				7700601		EA	FA		
54LS166	16	8-Bit Parallel-In/Serial-Out Shift Register	30609	8001701	/B	EA	FA		
54LS169	16	Up/Down Binary Counter			/B	EA			
54LS173	16	4-Bit D Register, 3-State			/B	EA			
54LS174	16	Hex D Flip-Flop with Clear	30106			EA	FA		
					/B	EA	FA		

6

**Table 12. Bipolar Logic (continued)**

**JM38535, SMD#, MIL-STD-883**

Device	Pins	Description	JM38535/	SMD#	883	Package Type and Lead Finish			
						DIL	FP	CAN	LCCC
54LS175	16	Quad D Flip-Flop with Clear	30107		/B	EA	FA		2A
54LS181	24	4-Bit ALU	30801		/B	JA	KA		N/A
54LS190	16	Up/Down Decade Counter	31513			EA			
54LS191	16	Up/Down Binary Counter	31509			EA	FA		2A
54LS192	16	Up/Down Decade Counter with Clear	31507	7600901	/B	EA			
54LS193	16	Up/Down Binary Counter with Clear	31508	7603601	/B	EA			
				7600601			FA		2A
54LS194A	16	4-Bit Right/Left Shift Register	30601		/B	EA			
54LS195A	16	4-Bit Shift Register (9300 Type)	30602		/B	EA	FA		
					/B	EA			2A
54LS20	14	Dual 4-Input NAND Gate	30007			CA	DA		
					/B	CA			2A
54LS21	14	Dual 4-Input AND Gate	31003			CA	DA		
					/B	CA			
54LS22	14	Dual 4-Input NAND Gate	30008			CA			
54LS221	16	Dual One-Shot (Very Stable)	31402			EA	FA		
				7604201	/B	EA			
54LS240	20	Octal Bus/Line Driver, Inverting 3-State	32401			RA	SA		2A
				7801201	/B	RA			2A
54LS241	20	Octal Bus/Line Driver, 3-State	32402		/B	RA			
54LS242	14	Quad Bus Transceiver, Inverting, 3-State	32801	8002001		CA			
54LS243	14	Quad Bus Transceiver, Non-Inverting, 3-State	32802		/B	CA	DA		
				8002002					2A
54LS244	20	Octal Driver, Non-Inverting, 3-State	32403	7705701	/B	RA	SA		2A
54LS245	20	Octal Bus Transceiver, Non-Inverting, 3-State	32803	8002101	/B	RA	SA		
54LS251	16	8-Input Multiplexer, 3-State	30905			EA	FA		
					/B	EA			
54LS253	16	Dual 4-Input Multiplexer, 3-State	30908			EA	FA		
				7601701		EA			
54LS257A	16	Quad 2-Input Multiplexer, Non-Inverting	30906		/B	EA			2A
				7603701		EA	FA		2A
					/B	EA			2A
54LS258A	16	Quad 2-Input Multiplexer, Inverting, 3-State	30907	7603801	/B	EA			
54LS259	16	8-Bit Addressable Latch (9334)	31603			EA	FA		
					/B	EA			2A
54LS26	14	Quad 2-Input NAND, High Voltage	32102	7602001	/B	CA			

**6**

Table 12. Bipolar Logic (continued)

JM38535, SMD#, MIL-STD-883

Device	Pins	Description	JM38535/	SMD#	883	Package Type and Lead Finish			
						DIL	FP	CAN	LCCC
54LS266	14	Quad Exclusive NOR Gate, Open-Collector	30303		/B	CA			
54LS27	14	Triple 3-Input NOR Gate	30302			CA	DA		
54LS273	20	Octal D Flip-Flop with Clear	32501		/B	CA			
54LS279	16	Quad Set/Reset Latch	31602	7801001	/B	RA	SA		2A
54LS28	14	Quad 2-Input NOR Buffer	30204			EA	FA		
54LS280	14	9-Bit Odd/Even Parity Generator/Checker	32901	7601801	/B	EA			2A
54LS283	16	4-Bit Full Adder (Rotated LS83A)	31202			CA			
54LS298	16	Quad 2-Multiplexer, with Output Register	30909	7604301	/B	CA	DA		2A
54LS30	14	8-Input NAND Gate	30009	7601901		EA			
54LS32	14	Quad 2-Input OR Gate	30501		/B	EA	FA		2A
54LS365A	16	Hex Buffer, Common Enable, 3-State	32201		/B	CA	DA		
54LS366A	16	Hex Inverter, Common Enable, 3-State	32202			EA	FA		
54LS367A	16	Hex Buffer, 4-Bit and 2-Bit, 3-State	32203			EA	FA		
54LS368A	16	Hex Inverter, 4-Bit and 2-Bit, 3-State	32204		/B	EA	FA		2A
54LS37	14	Quad 2-Input NAND Buffer	30202		/B	EA	FA		2A
54LS373	20	Octal Transparent Latch, 3-State	32502		/B	CA	DA		
54LS374	20	Octal D Flip-Flop	32503	7801101	/B	RA	SA		2A
54LS375	16	Quad Latch	31604			EA	FA		
54LS377	20	Octal D Flip-Flop with Enable	32504		/B				2A
54LS38	14	Dual 4-Input NAND Buffer	30203		/B	RA	SA		2A
54LS390	16	Dual Decade Counter		7802601	/B	CA	DA		2A
54LS393	14	Dual 4-Bit Binary Counter	32702			EA			
54LS399	16	Quad 2-Input Multiplexer with Output Register			/B	CA			
54LS40	14	Dual 4-Input NAND Buffer	30201			EA	FA		
54LS42A	16	1-of-10-Decoder	30703			CA	DA		
54LS47	16	BCD to 7-Segment Decoder/Driver	30704	7603101	/B	EA			
				7604501	/B	EA			

6

**Table 12. Bipolar Logic (continued)**

**JM38535, SMD#, MIL-STD-883**

Device	Pins	Description	JM38535/	SMD#	883	Package Type and Lead Finish			
						DIL	FP	CAN	LCCC
54LS51	14	Dual AND-OR-INVERT Gate	30401		/B	CA	DA		
54LS569	20	3-Bit Up/Down Counter, 3-State			/B	CA			2A
54LS645	20	Octal Bus Transceiver, Non-Inverting, 3-State			/B	RA			2A
54LS670	16	4 x 4 Register File, 3-State	31901	7704201	/B	EA			2A
54LS716	16	Programmable Modulo-N Counter			/B	EA			
54LS718	16	Programmable Modulo-N Counter			/B	EA			
54LS719	16	Programmable Modulo-N Counter			/B	EA			
54LS73A	14	Dual JK Flip-Flop	30101		/B	CA	DA		
54LS74A	14	Dual D Flip-Flop	30102		/B	CA	DA		2A
54LS75	16	4-Bit Bi-Stable Latch with Q and $\bar{Q}$	31601	7601201	/B	EA	FA		
54LS76A	16	Dual JK Flip-Flop	30110			EA	FA		
54LS85	16	4-Bit Magnitude Comparator	31101			EA	FA		
54LS86	14	Quad Exclusive OR Gate	30502		/B	CA	DA		2A
54LS95B	14	4-Bit Shift Register			/B	CA			2A

## Metal Gate CMOS

**Table 13. CMOS Logic**

**JM38535/, SMD#, MIL-STD-883**

Device	Pins	Description	JM38535/	SMD#	883	Package Type and Lead Finish			
						DIL	FP	CAN	LCCC
14001A	14	Quad 2-Input NOR Gate			/B	CA			
14001B	14	Quad 2-Input NOR Gate			/B	CA			
14002A	14	Dual 4-Input NOR Gate			/B	CA			
14007A	14	Dual Complementary Pair plus Inverter			/B	CA			
14011A	14	Quad 2-Input NAND Gate			/B	CA			
14011B	14	Quad 2-Input NAND Gate			/B	CA			
14012B	14	Dual 4-Input NAND Gate			/B	CA			
14013B	14	Dual D Flip-Flop			/B	CA			
14014B	16	8-Bit Static Shift Register			/B	EA			
14015B	16	Dual 4-Bit Static Shift Register			/B	EA			
14016B	14	Quad Analog Switch/Quad Multiplexer			/B	CA			
14017B	16	Decade Counter/Divider			/B	EA			
14018B	16	Presetable Divide-by-N Counter			/B	EA			
14020B	16	14-Bit Binary Counter			/B	EA			

**6**



Table 13. CMOS Logic (continued)

Device	Pins	Description	JM38535/	SMD#	883	Package Type and Lead Finish			
						DIL	FP	CAN	LCCC
14021B	16	8-Bit Static Shift Register			/B	EA			
14023A	14	Triple 3-Input NAND Gate			/B	CA			
14023B	14	Triple 3-Input NAND Gate			/B	CA			
14024B	14	7-Stage Ripple Counter			/B	CA			
14025A	14	Triple 3-Input NOR Gate			/B	CA			
14025B	14	Triple 3-Input NOR Gate			/B	CA			
14027B	16	Dual JK Flip-Flop			/B	EA			
14028B	16	BCD-to-Decimal Decoder			/B	EA			
14029B	16	4-Bit Presettable Up/Down Counter			/B	EA			
14040B	16	12-Bit Binary Counter			/B	EA			
14042B	16	Quad Latch			/B	EA			
14043B	16	Quad NOR R-S Latch			/B	EA			
14044B	16	Quad NOR R-S Latch			/B	EA			
14046B	16	Phased-Locked Loop			/B	EA			
14049A	16	Hex Inverter/Buffer			/B	EA			
14050B	16	Hex Buffer			/B	EA			
14051B	16	8-Channel Analog Multiplexer			/B	EA			
14052B	16	Analog Multiplexer, Dual 4-Channel			/B	EA			
14053B	16	Triple 2-Channel Analog Multiplexer			/B	EA			
14066B	14	Quad Analog Switch			/B	CA			
14069A	14	Hex Inverter			/B	CA			
14070B	14	Quad Exclusive OR Gate			/B	CA			
14071B	14	Quad 2-Input OR Gate			/B	CA			
14072B	14	Dual 4-Input OR Gate		7706001	/B	CA			
14073B	14	Triple 3-Input AND Gate		7705101	/B	CA			
14075B	14	Triple 3-Input OR Gate			/B	CA			
14076B	16	Quad D Register			/B	EA			
14081B	14	Quad 2-Input AND Gate		7702401	/B	CA			
14082B	14	Dual 4-Input AND Gate		7705901	/B	CA			
14093B	14	Quad 2-Input NAND Schmitt Trigger			/B	CA			
14094B	16	8-Bit Bus Compatible Shift/Store/Latch			/B	EA			
14099B	16	8-Bit Addressable Latch			/B	EA			
14161B	16	Binary Counter, Asynchronous Clear			/B	EA			
14174B	16	Hex D Flip-Flop			/B	EA			
14175B	16	Quad D Flip-Flop			/B	EA			
14490A	16	Hex Contact Bounce Eliminator		5962-8764601	/B	EA			
14502B	16	Strobed Hex Inverter/Buffer		7702001	/B	EA			
14503B	16	Hex 3-State Buffer			/B	EA			
14504B	16	Triple TTL or CMOS-to-CMOS Level Shifter			/B	EA			
14511B	16	BCD-to-7 Segment Latch/Decoder/Driver			/B	EA			
14512B	16	8-Channel Data Selector			/B	EA			

6

**Table 13. CMOS Logic (continued)**

Device	Pins	Description	JM38535/	SMD#	883	Package Type and Lead Finish			
						DIL	FP	CAN	LCCC
14517B	16	Dual 64-Bit Static Shift Register			/B	EA			
14518B	16	Dual BCD Up Counter			/B	EA			
14519B	16	4-Bit AND/OR Selector			/B	EA			
14520B	16	Dual Binary Up Counter			/B	EA			
14532B	16	8-Bit Priority Encoder			/B	EA			
14536B	16	Programmable Timer			/B	EA			
14538B	16	Dual Precision Monostable Multivibrator			/B	EA			
14539B	16	Dual 4-Channel Data Selector/Multiplexer			/B	EA			
14541B	14	Programmable Oscillator-Timer			/B	CA			
14555B	16	Dual Binary to 1-to-4-Decoder			/B	EA			
14557B	16	1-to-64-Bit Variable Length Shift Register		7901601	/B	EA			
14572A	16	Hex Gate			/B	EA			
14584B	14	Hex Schmitt Trigger		5962-8550102	/B	CA			
14585B	16	4-Bit Magnitude Comparator			/B	EA			

## Transistor To Transistor Logic (TTL)

**Table 14. Bipolar Logic**

**JM38535/, SMD#, MIL-STD-883**

Device	Pins	Description	JM38535/	SMD#	883	Package Type and Lead Finish			
						DIL	FP	CAN	LCCC
4324	14	Dual Voltage-Controlled Multivibrator				CA	DA		
4344	14	Phase-Frequency Detector		5962-8780301		CA	DA		

**6**

# Memories\*

**Table 15. Bipolar Memories**

**JM38535/, SMD#, MIL-STD-883**

Device	Pins	Description	JM38535/	SMD#	883	Package Type and Lead Finish			
						DIL	FP	CLCC	LCCC
10539	16	32 x 8-Bit ECL PROM, 17 ns			/B	EA	FA		
10545	16	64-Bit ECL Register File, RAM, 18 ns		5962-8856001	/B	EA	FA		
10549	16	256 x 4-Bit ECL PROM, 30 ns			/B	EA	FA		
10552	16	256 x 1-Bit ECL RAM, 15 ns			/B	EA	FA		
93415	16	1024 x 1-Bit RAM, Open-Collector	23101		/B	EA			
					/B		FA		
93422	22 24	256 x 4-Bit RAM, 3-State Output, 60 ns	23110		/B	WA			UA
					/B	WA			UA
93L422A	22 24	256 x 4-Bit RAM, 3-State Output, 55 ns, Low Power			/B	WA			UA
					/B				UA
93L422	22 24	256 x 4-Bit RAM, 3-State Output, 75 ns, Low Power	23112		/B	WA			UA
					/B				UA
93425	16	1024 x 1-Bit RAM, 3-State Output			/B	EA	FA		

**Table 16. Specialty SRAMs**

**JM38535/, SMD#, MIL-STD-883**

Device	Pins	Description	JM38535/	SMD#	883	Package Type and Lead Finish			
						SB DIL	CQF	CLCC	LCCC
56824A-25	52	8K x 24 DSP RAM, 25 ns			/B			3Q93	
56824A-30	52	8K x 24 DSP RAM, 30 ns			/B			3Q93	
62110-15	52	32K x 9 Sync. FSRAM, 15 ns, Dual I/O			/B		4Q93		
62110-25	52	32K x 9 Sync. FSRAM, 25 ns, Dual I/O			/B		4Q93		
62110-35	52	32K x 9 Sync. FSRAM, 35 ns, Dual I/O			/B		4Q93		
62486A-15	52	32K x 9 Sync. FSRAM, 15 ns, w/Burst Counter			/B		4Q93		
62486A-25	52	32K x 9 Sync. FSRAM, 25 ns, w/Burst Counter			/B		4Q93		
62486A-35	52	32K x 9 Sync. FSRAM, 35 ns, w/Burst Counter			/B		4Q93		
6294-30	28 32	16K x 4 Sync. FSRAM, 30 ns, Out Reg's, O/E			/B	XA			UA
					/B				UA
6294-35	28 32	16K x 4 Sync. FSRAM, 35 ns, Out Reg's, O/E			/B	XA			UA
					/B				UA
6294-40	28 32	16K x 4 Sync. FSRAM, 40 ns, Out Reg's, O/E			/B	XA			UA
					/B				UA
62940A-15	52	32K x 9 Sync. FSRAM, 15 ns, w/Burst Counter			/B		4Q93		
62940A-25	52	32K x 9 Sync. FSRAM, 25 ns, w/Burst Counter			/B		4Q93		
62940A-35	52	32K x 9 Sync. FSRAM, 35 ns, w/Burst Counter			/B		4Q93		
62995A-15	52	32K x 9 Sync. FSRAM, 15 ns, For R3000/96000			/B		4Q93		
62995A-25	52	32K x 9 Sync. FSRAM, 25 ns, For R3000/96000			/B		4Q93		

\*End-of-life, expires 20 January 1995. Does not include MultiChip Modules.

6

**Table 16. Specialty SRAMs (continued)**

**JM38535/, SMD#, MIL-STD-883**

Device	Pins	Description	JM38535/	SMD#	883	Package Type and Lead Finish			
						SB DIL	CQF	CLCC	LCCC
62995A-35	52	32K x 9 Sync. FSRAM, 35 ns, For R3000/96000			/B		4Q93		
62S950A-15	32	32K x 9 Sync. FSRAM, 15 ns			/B				3Q93
62S950A-25	32	32K x 9 Sync. FSRAM, 25 ns			/B				3Q93
62S950A-35	32	32K x 9 Sync. FSRAM, 35 ns			/B				3Q93

**Table 17. BiCMOS SRAMs**

**JM38535/, SMD#, MIL-STD-883**

Device	Pins	Description	JM38535/	SMD#	883	Package Type and Lead Finish			
						SB DIL	FP	CLCC	LCCC
6706A-15	28	32K x 8 BiCMOS FSRAM, 15 ns, O/E, TTL I/O			Com +	4Q93			
6706A-20	28	32K x 8 BiCMOS FSRAM, 20 ns, O/E, TTL I/O			Com +	4Q93			
6726A-15	32	128K x 8 BiCMOS FSRAM, 15 ns, TTL I/O			Com +	4Q93			
6726A-20	32	128K x 8 BiCMOS FSRAM, 20 ns, TTL I/O			Com +	4Q93			
6729A-15	28	256K x 4 BiCMOS FSRAM, 15 ns, TTL I/O			Com +	4Q93			
6729A-20	28	256K x 4 BiCMOS FSRAM, 20 ns, TTL I/O			Com +	4Q93			

**Table 18. CMOS DRAMs**

**JM38535/, SMD#, MIL-STD-883**

Device	Pins	Description	JM38535/	SMD#	883	Package Type and Lead Finish			
						SB DIL	CQF	CLCC	LCCC
511000A8	18	1M x 1 High Speed DRAM, Fast Page Mode, 80 ns			Com +	VA			
511000A8	20	1M x 1 High Speed DRAM, Fast Page Mode, 80 ns			Com +				UA
51L1000A8	18	1M x 1 High Speed DRAM, Fast Page Mode, 80 ns (Low Power)			Com +	VA			
51L1000A8	20	1M x 1 High Speed DRAM, Fast Page Mode, 80 ns (Low Power)			Com +				UA
511000A9	18	1M x 1 High Speed DRAM, Fast Page Mode, 90 ns			Com +	VA			
511000A9	20	1M x 1 High Speed DRAM, Fast Page Mode, 90 ns			Com +				UA
51L1000A9	18	1M x 1 High Speed DRAM, Fast Page Mode, 90 ns (Low Power)			Com +	VA			
51L1000A9	20	1M x 1 High Speed DRAM, Fast Page Mode, 90 ns (Low Power)			Com +				UA
511000A11	18	1M x 1 High Speed DRAM, Fast Page Mode, 110 ns			Com +	VA			

TBD To Be Determined (Based on Customer Demands)

\*End-of-life, expires 20 January 1995. Does not include MultiChip Modules.

**6**

**Table 18. CMOS DRAMs (continued)**

**JM38535/, SMD#, MIL-STD-883**

Device	Pins	Description	JM38535/	SMD#	883	Package Type and Lead Finish			
						SB DIL	CQF	CLCC	LCCC
511000A11	20	1M x 1 High Speed DRAM, Fast Page Mode, 110 ns			Com +				UA
51L1000A11	18	1M x 1 High Speed DRAM, Fast Page Mode, 110 ns (Low Power)			Com +	VA			
51L1000A11	20	1M x 1 High Speed DRAM, Fast Page Mode, 110 ns (Low Power)			Com +				UA
511000A12	18	1M x 1 High Speed DRAM, Fast Page Mode, 120 ns			Com +	VA			
511000A12	20	1M x 1 High Speed DRAM, Fast Page Mode, 120 ns			Com +				UA
51L1000A12	18	1M x 1 High Speed DRAM, Fast Page Mode, 120 ns (Low Power)			Com +	VA			
51L1000A12	20	1M x 1 High Speed DRAM, Fast Page Mode, 120 ns (Low Power)			Com +				UA
514256A8	20	256K x 4 DRAM, Fast Page Mode, 80 ns			Com +	RA			UA
51L4256A8	20	256K x 4 DRAM, Fast Page Mode, 80 ns			Com +	RA			UA
514256A9	20	256K x 4 DRAM, Fast Page Mode, 90 ns			Com +	RA			UA
51L4256A9	20	256K x 4 DRAM, Fast Page Mode, 90 ns			Com +	RA			UA
514256A11	20	256K x 4 DRAM, Fast Page Mode, 110 ns			Com +	RA			UA
51L4256A11	20	256K x 4 DRAM, Fast Page Mode, 110 ns			Com +	RA			UA
514256A12	20	256K x 4 DRAM, Fast Page Mode, 120 ns			Com +	RA			UA
51L4256A12	20	256K x 4 DRAM, Fast Page Mode, 120 ns			Com +	RA			UA
514400A7	20	1M x 4 DRAM, Fast Page Mode, 70 ns			Com +	4Q93			
514400A8	20	1M x 4 DRAM, Fast Page Mode, 80 ns			Com +	4Q93			
514400A9	20	1M x 4 DRAM, Fast Page Mode, 90 ns			Com +	4Q93			

TBD To Be Determined (Based on Customer Demands)

**6**

**Table 19. High Speed CMOS III Static Memories**

**JM38535/, SMD#, MIL-STD-883**

Device	Pins	Description	JM38535/	SMD#	883	Package Type and Lead Finish			
						DIL	FP	CLCC	LCCC
6205C-15	32	32K x 9 Fast Static RAM, 15 ns, ± C/E's O/E			/B	3Q93	4Q93		
6205C-20	32	32K x 9 Fast Static RAM, 20 ns, ± C/E's O/E			/B	3Q93	4Q93		
6205C-25	32	32K x 9 Fast Static RAM, 25 ns, ± C/E O/E			/B	3Q93	4Q93		
6206C-15	28	32K x 8 Fast Static RAM, 15 ns, ± C/E O/E			/B	3Q93	4Q93		
6206C-20	28	32K x 8 Fast Static RAM, 20 ns, ± C/E's O/E			/B	3Q93	4Q93		
6206C-25	28	32K x 8 Fast Static RAM, 25 ns, ± C/E O/E			/B	3Q93	4Q93		
6206C-35	28	32K x 8 Fast Static RAM, 35 ns, ± C/E O/E		5962-8866205	/B	XA			
6206C-45	28	32K x 8 Fast Static RAM, 45 ns, ± C/E O/E		5962-8866204	/B	XA			
6206C-55	28	32K x 8 Fast Static RAM, 55 ns, ± C/E O/E		5962-8866203	/B	XA			
6206C-70	28	32K x 8 Fast Static RAM, 70 ns, ± C/E O/E		5962-8866202	/B	XA			

TBD To Be Determined (Based on Customer Demands)

\*End-of-life, expires 20 January 1995. Does not include MultiChip Modules.

**Table 19. High Speed CMOS III Static Memories (continued)**

**JM38535/, SMD#, MIL-STD-883**

Device	Pins	Description	JM38535/	SMD#	883	Package Type and Lead Finish			
						DIL	FP	CLCC	LCCC
6206C-100	28	32K x 8 Fast Static RAM, 100 ns, ± C/E O/E		5962-8866201	/B	XA			
6226A-25	32	128K x 8 Fast Static RAM, 25 ns, ± C/E's O/E			Com +	XA	3Q93		3Q93
6226A-30	32	128K x 8 Fast Static RAM, 30 ns, ± C/E's O/E			Com +	XA	3Q93		3Q93
6226A-35	32	128K x 8 Fast Static RAM, 35 ns, ± C/E's O/E			Com +	XA	3Q93		3Q93
6226A-45	32	128K x 8 Fast Static RAM, 45 ns, ± C/E's O/E			Com +	XA	3Q93		3Q93
6226A-55	32	128K x 8 Fast Static RAM, 55 ns, ± C/E's O/E			Com +	XA	3Q93		3Q93
6226A-70	32	128K x 8 Fast Static RAM, 70 ns, ± C/E's O/E			Com +	XA	3Q93		3Q93
6226A-100	32	128K x 8 Fast Static RAM, 100 ns, ± C/E's O/E			Com +	XA	3Q93		3Q93
6229A-25	28	256K x 4 Fast Static RAM, 25 ns, ± C/E's O/E			Com +	4Q93			
6229A-25	32	256K x 4 Fast Static RAM, 25 ns, ± C/E's O/E			Com +		TBD		TBD
6229A-30	28	256K x 4 Fast Static RAM, 30 ns, ± C/E's O/E			Com +	4Q93			
6229A-30	32	256K x 4 Fast Static RAM, 30 ns, ± C/E's O/E			Com +		TBD		TBD
6229A-35	28	256K x 4 Fast Static RAM, 35 ns, ± C/E's O/E			Com +	4Q93			
6229A-35	32	256K x 4 Fast Static RAM, 35 ns, ± C/E's O/E			Com +		TBD		TBD
6229A-45	28	256K x 4 Fast Static RAM, 45 ns, ± C/E's O/E			Com +	4Q93			
6229A-45	32	256K x 4 Fast Static RAM, 45 ns, ± C/E's O/E			Com +		TBD		TBD
6229A-55	28	256K x 4 Fast Static RAM, 55 ns, ± C/E's O/E			Com +	4Q93			
6229A-55	32	256K x 4 Fast Static RAM, 55 ns, ± C/E's O/E			Com +		TBD		TBD
6229A-70	28	256K x 4 Fast Static RAM, 70 ns, ± C/E's O/E			Com +	4Q93			
6229A-70	32	256K x 4 Fast Static RAM, 70 ns, ± C/E's O/E			Com +		TBD		TBD
6229A-100	28	256K x 4 Fast Static RAM, 100 ns, ± C/E's O/E			Com +	4Q93			
6229A-100	32	256K x 4 Fast Static RAM, 100 ns, ± C/E's O/E			Com +		TBD		TBD
6264C-15	28	8K x 8 Fast Static RAM, 15 ns, ± C/E's		5962-3829419	/B	4Q93			
6264C-15	32	8K x 8 Fast Static RAM, 15 ns, ± C/E's		5962-3829419	/B				4Q93
6264C-20	28	8K x 8 Fast Static RAM, 20 ns, ± C/E's		5962-3829417	/B	4Q93			
6264C-20	32	8K x 8 Fast Static RAM, 20 ns, ± C/E's		5962-3829417	/B				4Q93
6264C-25	28	8K x 8 Fast Static RAM, 25 ns, ± C/E's		5962-3829415	/B	4Q93			
6264C-25	32	8K x 8 Fast Static RAM, 25 ns, ± C/E's		5962-3829415	/B				4Q93
6264C-35	28	8K x 8 Fast Static RAM, 35 ns, ± C/E's		5962-3829413	/B	MXA			
6264C-35	32	8K x 8 Fast Static RAM, 35 ns, ± C/E's		5962-3829413	/B				4Q93
6264C-45	28	8K x 8 Fast Static RAM, 45 ns, ± C/E's		5962-3829411	/B	MXA			
6264C-45	32	8K x 8 Fast Static RAM, 45 ns, ± C/E's		5962-3829411	/B				4Q93
6264C-55	28	8K x 8 Fast Static RAM, 55 ns, ± C/E's		5962-3829409	/B	MXA			
6264C-55	32	8K x 8 Fast Static RAM, 55 ns, ± C/E's		5962-3829409	/B				4Q93
6264C-70	28	8K x 8 Fast Static RAM, 70 ns, ± C/E's		5962-3829407	/B	MXA			
6264C-70	32	8K x 8 Fast Static RAM, 70 ns, ± C/E's		5962-3829407	/B				4Q93
6268-35	20	4K x 4 Fast Static RAM, 35 ns, C/E		5962-8670503	/B	RA	YA		XA
						RA	YA		UA
6268-45	20	4K x 4 Fast Static RAM, 45 ns, C/E		5962-8670505	/B	RA	YA		XA
						RA	YA		UA

TBD To Be Determined (Based on Customer Demands)

\*End-of-life, expires 20 January 1995. Does not include MultiChip Modules.

**6**

**Table 19. High Speed CMOS III Static Memories (continued)**

**JM38535/, SMD#, MIL-STD-883**

Device	Pins	Description	JM38535/	SMD#	883	Package Type and Lead Finish			
						DIL	FP	CLCC	LCCC
6268-55	20	4K x 4 Fast Static RAM, 55 ns, C/E		5962-8670507	/B	RA RA	YA YA		XA UA
6268-70	20	4K x 4 Fast Static RAM, 70 ns, C/E		5962-8670509	/B	RA RA	YA YA		XA UA
6287-35	22	64K x 1 Fast Static RAM, 35 ns, C/E		5962-8601501	/B	XA XA			ZA UA
6287-45	22	64K x 1 Fast Static RAM, 45 ns, C/E		5962-8601503	/B	XA XA			ZA UA
6288C-15	22	16K x 4 Fast Static RAM, 15 ns, C/E			/B	4Q93			4Q93
6288C-20	22	16K x 4 Fast Static RAM, 20 ns, C/E			/B	4Q93			4Q93
6288C-25	22	16K x 4 Fast Static RAM, 25 ns, C/E			/B	4Q93			4Q93
6288C-35	22	16K x 4 Fast Static RAM, 35 ns, C/E			/B	XA			UA
6288C-45	22	16K x 4 Fast Static RAM, 45 ns, C/E			/B	XA			UA

TBD To Be Determined (Based on Customer Demands)

## Microprocessors

**Table 20. 8-Bit Microprocessors**

**JM38535/, SMD#, MIL-STD-883**

Device	Pins	Description	JM38535/	SMD#	883	Package Type and Lead Finish			
						DIL	PGA	LCCC	CLCC
6800	40	8-Bit Microprocessor			/B	QA			
6802	40	8-Bit Microprocessor with Clock and Optional RAM			/B	QA			
6809	40	8-Bit Microprocessor with Clock			/B	QA			
68A09	40	1.5 MHz 8-Bit Microprocessor with Clock			/B	QA			
68B09	40	2.0 MHz 8-Bit Microprocessor with Clock			/B	QA			
6821	40	8-Bit Peripheral Interface Adapter			/B	QA			
68A21	40	1.5 MHz 8-Bit Peripheral Interface Adapter			/B	QA			
68B21	40	2.0 MHz 8-Bit Peripheral Interface Adapter			/B	QA			
6840	28	Programmable Timer Module			/B	XA			
6845	40	CRT Controller			/B	QA			
68488	40	GPIA Support Module			/B	QA			
68A488	40	1.5 MHz GPIA Support Module			/B	QA			
68B488	40	2.0 MHz GPIA Support Module			/B	QA			
6850	24	Asynchronous Communications Interface Adapter			/B	JA			
68A50	24	1.5 MHz Asynchronous Communications Interface Adapter			/B	JA			
68B50	24	2.0 MHz Asynchronous Communications Interface Adapter			/B	JA			

**NOTICE:** Commercial Plus products are not necessarily pin-for-pin compatible with their commercial product counterparts. If there are any questions as to the compatibility please contact Product Marketing (602) 897-3782 for detailed information.

\*End-of-life, expires 20 January 1995. Does not include MultiChip Modules.

6

**Table 20. 8-Bit Microprocessors (continued)**

**JM38535/, SMD#, MIL-STD-883**

Device	Pins	Description	JM38535/	SMD#	883	Package Type and Lead Finish			
						DIL	PGA	LCCC	CLCC
6852	24	Synchronous Serial Data Adapter			/B	JA			
6854	28	Advanced Data-Link Controller			/B	XA			
6875A	16	6800 Clock Generator/Driver			/B	EA			

**NOTICE:** Commercial Plus products are not necessarily pin-for-pin compatible with their commercial product counterparts. If there are any questions as to the compatibility please contact Product Marketing (602) 897-3782 for detailed information.

**Table 21. 16- and 32-Bit Microprocessors**

**JM38535/, SMD#, MIL-STD-883**

Device	Pins	Description	JM38535/	SMD#	883	Package Type and Lead Finish			
						DIL	PGA	LCCC	CLCC
68000-8*	64	16-Bit external/32-Bit internal		8202102		YA			
	68						TA		UC
	64								
	68					XA			
68000-10*	64	16-Bit external/32-Bit internal		8202103			ZA		YC
	68						TA		UC
	64					XA			YC
	68								
68020-16	114	32-Bit external and internal		5962-8603202			XA		
	132	32-Bit external and internal		5962-8603202		/B			YC
	114					/B		ZA	
68020-20	114	32-Bit external and internal		5962-8603203			XA		
	132	32-Bit external and internal		5962-8603203		/B			YC
	114					/B		ZA	
68020-25	114	32-Bit external and internal		5962-86032			***		
	132	32-Bit external and internal		5962-86032		/B			***
	114					/B		ZA	
68030-16	128	32-Bit external and internal w/built-in PMMU		5962-8946401			XA		
	132	32-Bit external and internal w/built-in PMMU		5962-8946401		/B			YC**
	128					/B		ZA	
68030-20	128	32-Bit external and internal w/built-in PMMU		5962-8946402			XA		
	132	32-Bit external and internal w/built-in PMMU		5962-8946402		/B			YC**
	128					/B		ZA	
68030-25	128	32-Bit external and internal w/built-in PMMU		5962-8946403			XA		
	132	32-Bit external and internal w/built-in PMMU		5962-8946403		/B			YC**
	128					/B		ZA	
68030-33	128	32-Bit external and internal w/built-in PMMU		5962-8946404			XA		
	132	32-Bit external and internal w/built-in PMMU		5962-8946404		/B			YC**
	128					/B		ZA	
68040-25	179	32-Bit external and internal w/built-in PMMU and FPU		5962-93143	/B		1H94		

6

**NOTICE:** Commercial Plus products are not necessarily pin-for-pin compatible with their commercial product counterparts. If there are any questions as to the compatibility please contact Product Marketing (602) 897-3782 for detailed information.

Note 1: Parts are shipped in Non-Conductive Ring (Non-Lead Formed).

\* [T<sub>C</sub> = -55° to +110°C]

\*\* This device includes thermal pad(s).

\*\*\*SMD submitted to DESC.

\*End-of-life, expires 20 January 1995. Does not include MultiChip Modules.



**Table 21. 16- and 32-Bit Microprocessors (continued)**

**JM38535/, SMD#, MIL-STD-883**

Device	Pins	Description	JM38535/	SMD#	883	Package Type and Lead Finish			
						DIL	PGA	LCCC	CLCC
68040-25	196	32-Bit external and internal w/built-in PMMU and FPU		5962-93143	/B				1H94 Note 1
68150	68	32-Bit to 32/18/8 Bit Dynamic Read/Write Bus Sizer		Planned	/B				4Q94
68882-16	68	Enhanced 16 MHz 32-Bit Floating Point Coprocessor		5962-8946301	/B		*** ZA		*** YC
68882-20	68	Enhanced 20 MHz 32-Bit Floating Point Coprocessor		5962-8946302	/B		*** ZA		*** YC
68882-25	68	Enhanced 25 MHz 32-Bit Floating Point Coprocessor		5962-8946303	/B		*** ZA		*** YC
68882-33	68	Enhanced 33 MHz 32-Bit Floating Point Coprocessor		5962-8946304	/B		*** ZA		*** YC
68HC000-8	64	16-Bit external/32-Bit internal HCMOS MPU		5962-89462		***			***
	68	16-Bit external/32-Bit internal HCMOS MPU		5962-89462					***
	64				/B	XA			YC
	68				/B		ZA		YC
68HC000-10	64	16-Bit external/32-Bit internal HCMOS MPU		5962-89462		***			***
	68	16-Bit external/32-Bit internal HCMOS MPU		5962-89462					***
	64				/B	XA			YC
	68				/B		ZA		YC
68HC000-12	64	16-Bit external/32-Bit internal HCMOS MPU		5962-89462		***			***
	68	16-Bit external/32-Bit internal HCMOS MPU		5962-89462					***
	64				/B	XA			YC
	68				/B		ZA		YC
68HC001-8	68	Configurable 16-Bit or 8-Bit MPU		TBD	/B		ZA		***

NOTICE: Commercial Plus products are not necessarily pin-for-pin compatible with their commercial product counterparts. If there are any questions as to the compatibility please contact Product Marketing (602) 897-3782 for detailed information.

Note 1: Parts are shipped in Non-Conductive Ring (Non-Lead Formed).

\* [T<sub>C</sub> = -55° to +110°C]

\*\* This device includes thermal pad(s).

\*\*\*SMD submitted to DESC.

**6**

## Single Chip Microcontrollers

**Table 22. Single Chip Microcontrollers**

**JM38535/, SMD#, MIL-STD-883**

Device	Pins	Description	JM38535/	SMD#	883	Package Type and Lead Finish			
						DIL	PGA	LCCC	CLCC
68HC11A0	48	8-Bit Microcontroller with 256 Bytes RAM		5962-9051001		XA			
	52	8-Bit Microcontroller with 256 Bytes RAM		5962-9051001	/B				YC
68HC11A1	48	8-Bit Microcontroller, 256 Bytes RAM & 512 Bytes EEPROM		5962-9051002	/B	XA			
	52	8-Bit Microcontroller, 256 Bytes RAM & 512 Bytes EEPROM		5962-9051002	/B				YC YC
68HC16Z1	132	16-Bit MCU, with Analog to Digital Converter		Planned	/B		2Q94		

\*SMD submitted to DESC.

\*End-of-life, expires 20 January 1995. Does not include MultiChip Modules.

**Table 22. Single Chip Microcontrollers (continued)**

**JM38535/, SMD#, MIL-STD-883**

Device	Pins	Description	JM38535/	SMD#	883	Package Type and Lead Finish			
						DIL	PGA	LCCC	CLCC
68HC711K4	84	8-Bit Microcontroller with 24K EPROM		Planned	/B		1Q94		
68HC811E2	48	8-Bit Microcontroller with 2K EEPROM		5962-8952701	/B	XA			
	52	8-Bit Microcontroller with 2K EEPROM		5962-8952701	/B				YC
68332-16	132	32-Bit Microcontroller		5962-91501			ZA		YC
68340	144	32-Bit MCU with DMA		Planned	/B		ZA		
68F333	160	32-Bit Microcontroller with Flash EEPROM		Planned	/B		TBD		TBD

\*SMD submitted to DESC.

## Data Communications

**Table 23. Data Communications**

**JM38535/, SMD#, MIL-STD-883**

Device	Pins	Description	JM38535/	SMD#	883	Package Type and Lead Finish			
						DIL	PGA	LCCC	CLCC
68302-16	132	Integrated Multi-Protocol Processor		Planned	/B		ZA		YC

## Digital Signal Processing (DSP)

**Table 24. DSP Digital Signal Processing**

**JM38535/, SMD#, MIL-STD-883**

Device	Pins	Description	JM38535/	SMD#	883	Package Type and Lead Finish			
						DIL	PGA	LCCC	CLCC
56001-20	88	56-Bit Digital Signal Processor		5962-8951201	/B		XA		YC
	100	56-Bit Digital Signal Processor					ZA		YC
56002-40	132	56-Bit General Purpose Digital Signal Processor			/B		4Q93		1Q94
96002-33	223	96-Bit Floating Point Digital Signal Processor		5962-93150	/B		4Q93		TBD
	223	96-Bit Floating Point Digital Signal Processor					ZA		TBD
56156	112	16-Bit General Purpose RAM DSP with $\Sigma\Delta$ Codec			/B				TBD
56ADC16	20	16-Bit $\Sigma\Delta$ A/D			/B		1Q94		

NOTICE: Commercial Plus products are not necessarily pin-for-pin compatible with their commercial product counterparts. If there are any questions as to the compatibility please contact Product Marketing (602) 897-3782 for detailed information.

TBD To Be Determined (Based on Customer Demands)

6

\*End-of-life, expires 20 January 1995. Does not include MultiChip Modules.

## Reduced Instruction Set Computer (RISC)

Table 25. RISC

JM38535/, SMD#, MIL-STD-883

Device	Pins	Description	JM38535/	SMD#	883	Package Type and Lead Finish			
						DIL	PGA	LCCC	CLCC
88100-20	180	32-Bit RISC		Planned	/B		ZA		
	200	32-Bit RISC		Planned	/B				4Q93 <sup>1</sup>
88200-20	180	16K Cache/Memory Management Unit		Planned			ZA		
	200	16K Cache/Memory Management Unit		Planned					4Q93 <sup>1</sup>

<sup>1</sup>Parts are shipped in Non-Conductive Ring (Non-Lead Formed).  
TBD To Be Determined (Based on Customer Demands)

## Application Specific Integrated Circuit (ASIC)

Table 26. ASIC

MIL-STD-883

Device	Pins	Description	JM38535/	SMD#	883	Package Type and Lead Finish			
						DIL	PGA	CLCC	LCCC
H4C018	136	18K Gate Array in H4C Technology also available as CDA™			/B		ZA	YC <sup>1</sup>	
H4C027	160	27K Gate Array in H4C Technology also available as CDA™			/B		ZA	YC <sup>1</sup>	
H4C035	176	35K Gate Array in H4C Technology also available as CDA™			/B		ZA	YC <sup>1</sup>	
H4C057	216	57K Gate Array in H4C Technology also available as CDA™			/B		ZA	YC <sup>1</sup>	
H4C086	256	86K Gate Array in H4C Technology also available as CDA™			/B		ZA	YC <sup>1</sup>	
H4C123	304	123K Gate Array in H4C Technology also available as CDA™			/B		ZA	YC <sup>1</sup>	
H4C161	344	161K Gate Array in H4C Technology also available as CDA™			/B		ZA	YC <sup>1</sup>	
H4C195	376	195K Gate Array in H4C Technology also available as CDA™			/B		ZA	YC <sup>1</sup>	
H4C267	436	256K Gate Array in H4C Technology also available as CDA™			/B		ZA	YC <sup>1</sup>	
H4C318	464	318K Gate Array in H4C Technology also available as CDA™			/B		ZA	YC <sup>1</sup>	
68902A	68	USART CMOS version of 68901			/B		ZA	YC <sup>1</sup>	

<sup>1</sup>Parts are shipped in Non-Conductive Ring (Non-Lead Formed).

6

\*End-of-life, expires 20 January 1995. Does not include MultiChip Modules.

# MultiChip Modules (MCMs)

**Table 27. Multichip Module**

MIL-STD-883

Device	Pins	Description	Commercial-/Avionics	883	Package Type and Lead Finish			
					PGA	LCCC	CLCC	LGA
46226	68	4 Megabit 128K x 32 Bit SRAM	Planned				3Q93	
462110	420	Four 32K x 9 Synchronous Dual I/O SRAM	Planned	/B				TBD
188100	240	(1) 88100 and (2) 88200 Cache	Planned		4Q93			3Q93
196002	240	(1) 96002 DSP and (1) 128K x 32 Bit SRAM	Planned	/B	TBD			
				/B	TBD			

TBD To Be Determined (Based on Customer Demands)

\*End-of-life, expires 20 January 1995. Does not include MultiChip Modules.

**6**

# CPTO Discrete Products

---

## In Brief . . .

In brief, Motorola serves today's discrete military/aerospace semiconductor market with the industry's broadest range of JAN, JANTX, JANTXV and JANS products. We are qualified suppliers of current QPL Mil specifications, and the inventory's expanding rapidly as additional qualifications are being actively pursued.

But the actual requirements for today's high technology military and space applications often go beyond the MIL-S-19500 qualified components. Normally, these additional needs are met with devices manufactured to each customer's unique specifications, resulting in low-volume production, high initial cost and long delivery time.

To reduce these detriments, Motorola now offers a supplementary line of popular packaged and unpackaged components (chips) for which no military specifications exist, but which have been processed to rigid MIL-S-19500 and MIL-STD-750 specifications, just as if they were built for JAN registration. Since no military slash sheets exist for these components, the electrical parameters are those applied to equivalent commercial products, but delta calculations and Group B and C test limits are selected to the same criteria as for MIL-5-19500 specifications.

Compared with custom equivalents, these components should result in significant savings in both cost and delivery time. Moreover, the life span of such devices will be considerably longer than that of custom-built "specials", so that cost effective replacements will be available for the foreseeable future.

This Selector Guide provides an overview of existing discrete products available off-the-shelf for the Hi-Rel market. Additional high reliability selections from Motorola's large repertoire of discrete products may be obtained on special order by contacting a sales representative at any Motorola sales office.

	<b>Page</b>
Product Listing . . . . .	6.3-2
MIL-Qualified Products . . . . .	6.3-2
MIL-Processed Packaged Products . . . . .	6.3-5
Product Selection Guide . . . . .	6.3-6
MIL-Qualified Products . . . . .	6.3-6
Power Transistors . . . . .	6.3-6
Small-Signal Transistors . . . . .	6.3-8
Bipolar . . . . .	6.3-8
JFETs . . . . .	6.3-11
Mil-Processed Discrete Semiconductors . . . . .	6.3-12
Power Transistors . . . . .	6.3-14
Small-Signal Transistors . . . . .	6.3-15
Multiple Transistors . . . . .	6.3-16
Surface Mounted Devices . . . . .	6.3-17
RF Power Devices . . . . .	6.3-17
CPTO Discrete Chips . . . . .	6.3-18
Selector Guide . . . . .	6.3-21

# Product Listing

## MIL-Qualified Products

The following table lists Motorola-supplied devices which appear on the QPL-19500 list as JAN, JANTX, JANTXV and JANS qualified products. (Although Motorola will continue to supply components to JAN specifications where desired, this classification has been declared "inactive for new designs," per MIL-S-19500. The higher level JANTX classification is a recommended replacement.) As the detail specifications are being revised, JAN level is being removed. Consult your local sales office for specific JAN availability.

**Table 1. MIL-Qualified Products**

Type Number	Detailed Spec	Specification Levels			
		JAN	JTX	JTXV	JANS
<b>TRANSISTORS</b>					
<b>Small-Signal</b>					
2N708	/312		X		
2N869A	/283		X		
2N918	/301	X	X	X	
2N930	/253	X	X		
2N2060	/270		X		X
2N2219A	/251	X	X	X	X
2N2222	/255	X	X		
2N2222A	/255	X	X	X	X
2N2369A	/317	X	X	X	X
2N2484	/376	X	X	X	X
2N2605	/354		X		X
2N2609	/296	X			
2N2904	/290		X		
2N2905A	/290	X	X	X	X
2N2906A	/291		X		
2N2907	/291	X	X		
2N2907A	/291	X	X	X	X
2N2920	/355	X	X	X	X
2N3013	/287		X		
2N3019S	/391	X	X	X	X
2N3251A	/323	X	X		
2N3439	/368		X	X	
2N3440	/368		X	X	
2N3467	/348		X	X	
2N3486A	/392		X		
2N3501	/366	X	X	X	X
2N3506	/349		X	X	
2N3507	/349		X	X	
2N3584	/384		X	X	
2N3585	/384		X	X	
2N3634	/357		X	X	
2N3636			X	X	X
2N3637	/357		X	X	X
2N3700	/391	X	X	X	X
<b>Power</b>					
2N3715	/408		X		
2N3716	/408		X	X	
<b>Small-Signal</b>					
2N3735	/395		X		
2N3737	/395		X		
<b>Power</b>					
2N3739	/402		X		
2N3740	/441		X	X	
2N3741	/441		X	X	

6

Table 1. MIL-Qualified Products (continued)

Type Number	Detailed Spec	Specification Levels			
		JAN	JTX	JTXV	JANS
<b>Small-Signal</b>					
2N3743	/397		X	X	
2N3764	/396		X	X	X
<b>Power</b>					
2N3766	/518		X		
2N3767	/518	X	X	X	
2N3771	/413	X	X	X	
2N3772	/413	X	X	X	
2N3792	/379	X	X	X	
<b>Small-Signal</b>					
2N3810	/336		X		
2N3811	/336		X	X	X
2N3821	/375		X		X
<b>Power</b>					
2N3867S	/350		X		
2N3868S	/350		X	X	
2N3879	/526	X	X	X	
<b>Small-Signal</b>					
2N4033	/512	X	X	X	
2N4261	/511		X		
<b>Power</b>					
2N4399	/433		X	X	
<b>Small-Signal</b>					
2N4405	/448	X	X		
2N4416A	/428		X	X	
2N4449	/317		X		
2N4854	/421		X	X	
2N4856					
through					
2N4858	/385		X	X	
2N4931	/397		X	X	
<b>TRANSISTORS</b>					
<b>Power</b>					
2N5038	/439	X	X	X	
2N5039	/439		X		
2N5302	/456	X	X	X	
2N5303	/456		X	X	
2N5339	/560	X	X	X	
<b>Small-Signal</b>					
2N5416S	/485	X	X		
2N5582	/423	X	X		
<b>Power</b>					
2N5683	/466		X		
2N5684	/466	X	X	X	
2N5685	/464		X		
2N5686	/464		X	X	
2N5745	/433		X	X	

6



Table 1. MIL-Qualified Products (continued)

Type Number	Detailed Spec	Specification Levels			
		JAN	JTX	JTXV	JANS
<b>TRANSISTORS</b>					
<b>Small-Signal</b>					
2N5794	/495		X		
2N5796	/496		X		
<b>TRANSISTORS</b>					
<b>Power</b>					
2N6051	/501		X	X	
2N6052	/501	X	X	X	
2N6058	/502		X		
2N6059	/502	X	X	X	
2N6193	/561	X	X	X	
2N6211					
through					
2N6213	/461	X	X	X	
2N6274	/514	X	X	X	
2N6277	/514		X	X	
2N6283	/504		X		
2N6284	/504		X	X	
2N6286	/505		X		
2N6287	/505		X	X	
2N6298	/540		X		
2N6299	/540	X	X	X	
2N6300	/539		X		
2N6301	/539	X	X	X	
2N6306	/498	X	X		
2N6308	/498		X		
2N6338	/509	X	X		
2N6341	/509	X	X	X	
2N6378	/515		X		
2N6379	/515		X		
2N6385	/523	X	X	X	
2N6437	/508	X	X	X	
2N6438	/508	X	X	X	
2N6546	/525		X		
2N6547	/525	X	X		
2N6650	/527	X	X	X	
<b>Multiples</b>					
2N6987	/558		X	X	
2N6988	/558			X	
2N6989	/559		X	X	
2N6990	/559			X	

6

**Product Listing (continued)**

**MIL-Processed Packaged Products**

The following type numbers represent standard part numbers that have been built and tested to MIL-S-19500 reliability specifications. For details, see page 6.1-17.

**Table 2. MIL-Processed Products**

Type Number	Motorola Standard Part Number	Specification Levels		
		JAN	JTX	JTXV

**TRANSISTORS**

**Duals**

MD2369A	2N2369A		HX	HXV
MD3251A	2N3251A		HX	HXV
MD3468	2N3468		HX	HXV
MD6002	MD6002		HX	HXV
MD918	2N918			HXV

**Quads**

MHQ2369	2N2369A		HX	HXV
MHQ2484	2N2484		HX	HXV
MHQ3251A	2N3251A		HX	HXV
MHQ3468	2N3468		HX	HXV
MHQ6002	2N2222/2907		HX	HXV
MHQ918	2N918		HX	HXV

**Bipolar Power**

MJ6316	2N6316		HX	HXV
MJ6318	2N6318		HX	HXV
MJ10016	MJ10016		HX	HXV
MJ11021	MJ11021		HX	HXV
MJ11022	MJ11022		HX	HXV
MJ11032	MJ11032		HX	HXV
MJ11033	MJ11033		HX	HXV

**TRANSISTORS**

**Quads, Flat Packs**

MQ2369A	2N2369A			HXV
MQ2484	2N2484			HXV
MQ2605	2N2605			HXV
MQ3251A	2N3251A			HXV
MQ3468	2N3468			HXV
MQ6002	MQ6002			HXV
MQ918	2N918			HXV

**RF**

MRF522	MRF522			HXV
MRF2857	2N2857		HX	HXV
MRF3866A	2N3866A		HX	HXV
MRF4957	2N4957		HX	HXV
MRF5109	2N5109		HX	HXV
MRF5583	2N5583		HX	HXV
MRF6603	2N6603			HXV
MRF6604	2N6604			HXV

**6**

# Product Selection Guide

## MIL-Qualified Products

Motorola MIL qualified components are ordered by adding suffix JAN, JTX, JTXV or JANS to the part numbers indicated in the following tables. Although Motorola will continue to supply components to the JAN specification, this classification has been declared "inactive for new designs" per MIL-STD-19500. The higher level, JTX, is the recommended replacement.

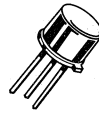

CASE 79-04  
TO-205AD  
(TO-39)

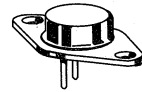

CASE 80-02  
TO-213AA (TO-66)

## Power Transistors

Table 3. Bipolar

I <sub>C</sub> Cont Amps Max	V <sub>CE0(sus)</sub> Volts Min	Device Type		Resistive Switching			V <sub>CE(sat)</sub> Max Vdc	I <sub>C/B</sub> A/mA	P <sub>D</sub> (Case) Watts @ 25°C
		NPN	PNP	h <sub>FE</sub> Min/Max	I <sub>C</sub> Amp	t <sub>on</sub> /t <sub>off</sub> μs Max			
TO-204AA/AE (Formerly TO-3)									
8	250	2N6306		15/75	3	0.6/3	0.8	3/0.6	125
	350	2N6308		Oct-52	3	0.6/3	1.5	3/0.6	125
10	60	2N3715		50/150	1	—/2	1	5/0.5	150
	80	2N3716	2N3792	50/150	1	—/2	1	5/0.5	150
12	80	2N6385#	2N6650	1k/20k	5	2.5/10	2	5/0.01	100**
	100	2N6058#	2N6051#	1k/18k	6	2/10	2	6/0.024	150
15	300	2N6059#	2N6052#	1k/18k	6	2/10	2	6/0.024	150
	400	2N6546		6/—	10	1/4.7	5	15/3	175
20	75	2N6547		6/—	10	1/4.7	5	15/3	175
	80	2N5039		20/—	10	0.5/2	1	10/1	140
25	80	2N5303		15/60	10	0.9*/1*	1	10/1	200
			2N5745	15/60	10	1.5*/1*	1	10/1	200
		2N6283#	2N6286#	1250/18k	10	2/10	2	10/0.04	175
	90	2N5038		20/—	12	0.5/2	1	12/1.2	140
30	100	2N6284#	2N6287#	1250/18k	10	2/10	2	10/0.04	175
	120		2N6437	30/120	10	0.5/1.25	1	10/1	200
30	100		2N6438	30/120	10	0.5/1.25	1	10/1	200
	60	2N5302		15/60	15	2*/1*	1	15/1.5	200
50	60		2N4399	15/60	15	—/2.1	1	15/1.5	200
	80	2N5685	2N5683•	15/60	25	1.5/3	1	25/2.5	300
100	80	2N5686•	2N5684•	15/60	25	1.5/3	1	25/2.5	300
	100		2N6378•	30/120	20	0.5/1.05	1	20/2	250
120	100	2N6274•		30/120	20	0.5/1.05	1	20/2	250
	120		2N6379•	30/120	20	0.5/1.05	1	20/2	250
150	150	2N6277•		30/120	20	0.5/1.05	1	20/2	250

#Darlington, + T<sub>C</sub> = 0°C for devices 2N6300, 2N6301

• TO-204AE; all others TO-204AA

\*\*P<sub>D</sub> = 85 for devices 2N6648, 2N6649 and 2N6650.

t<sub>on</sub>/t<sub>off</sub>

6

**Table 3. Bipolar (continued)**

I <sub>C</sub> Cont Amps Max	V <sub>CEO(sus)</sub> Volts Min	Device Type		Resistive Switching			V <sub>CE(sat)</sub> Max Vdc	I <sub>C</sub> /I <sub>B</sub> A/mA	P <sub>D</sub> (Case) Watts @ 25°C
		NPN	PNP	hFE Min/Max @ I <sub>C</sub> Amp	t <sub>on</sub> /t <sub>off</sub> μs Max				
<b>TO-205AD (Formerly TO-39)</b>									
3	40		2N3867S	40/200	1.5	65*/100*	0.75	1.5/150	10
	60		2N3868S	30/150	1.5	65*/100*	0.75	1.5/150	10
5	100	2N5339	2N6193	60/240	2	100*/200*	0.7	2/200	1
<b>TO-213AA (Formerly TO-66)</b>									
1	300	2N3739		40/200	0.1	1.5/3.5	0.75	0.1/10	20
4	60		2N3740	30/120	0.25	0.4/1	0.4	0.25/25	25
			2N3766	40/160	0.5	0.25/2.5	1	0.5/50	25
	80		2N3741	30/120	0.25	0.4/1	0.4	0.25/250	25
			2N3767	40/160	0.5	0.25/2.5	1	0.5/50	25
8	60	2N6300#	2N6298#	750/18k	4	2/8	4	4/16	75+
	80	2N6301#	2N6299#	750/18k	4	2/8	4	4/16	75+

#Darlington, + T<sub>C</sub> = 0°C for devices 2N6300, 2N6301

• TO-204AE; all others TO-204AA

\*\*P<sub>D</sub> = 85 for devices 2N6648, 2N6649 and 2N6650.

t<sub>r</sub>\*/t<sub>f</sub>\*

## Small-Signal Transistors

### Bipolar

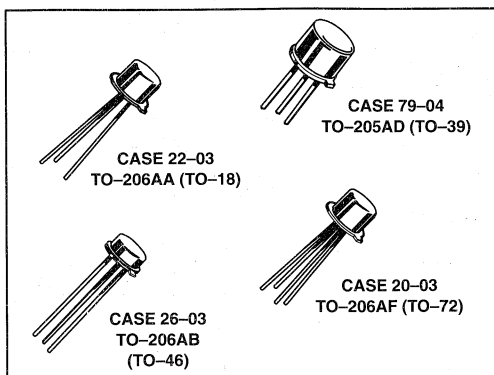
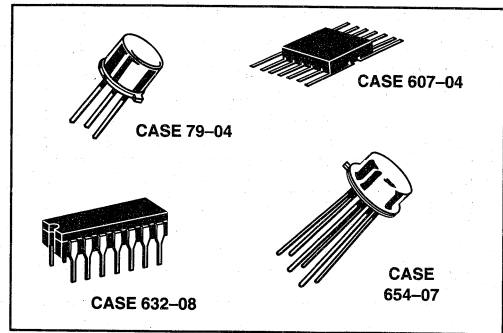

Table 4. General Purpose

Package	Device Number	$V_{(BR)CEO}$ Volts Min	$I_C$ mA Max	$h_{FE}$		$I_C$ mA	$V_{CE(sat)}$ Volts Max	$I_C/I_B$ mA
				Min	Max			
<b>NPN</b>								
TO-206AA (TO-18)	2N3700	80	1000	50	200	500	0.5	500/50
	2N2484	60	50	200	500	0.01	0.3	1.0/0.1
	2N2222A	50	800	75	325	1	1.2	150/15
	2N930	45	30	100	300	0.01	1	10/0.5
	2N2222	30	800	50	325	1	1.3	150/15
TO-205AD (TO-39)	2N3019S	80	1000	100	300	150	0.2	150/15
	2N2219A	50	800	100	300	150	0.3	150/15
TO-206AB (TO-46)	2N5582	50	800	100	300	150	0.3	150/15
<b>PNP</b>								
TO-206AA (TO-18)	2N2906A	60	600	40	120	150	0.4	150/15
	2N2907A	60	600	100	300	150	0.4	10/1.0
	2N3251A	60	200	100	300	10	0.25	10/1.0
	2N2907	40	600	100	300	150	0.4	150/15
TO-205AD (TO-39)	2N4033	80	1000	100	300	100	0.15	150/15
	2N4405	80	500	100	300	150	0.2	150/15
	2N2905A	60	600	100	300	1	0.4	150/15
	2N2904	40	600	40	120	1	0.4	150/15
TO-206AB (TO-46)	2N3486A	60	600	100	300	150	0.4	150/15
	2N2605	60	30	100	400	10	0.3	10/0.5

6

## Bipolar (continued)



**Table 5. High-Frequency Amplifiers/Oscillators**

The transistors shown are designed for use as both oscillators and amplifiers at UHF and VHF frequencies.

Package	Device Number	V(BR)CEO Volts Min	hFE @ Min   I <sub>C</sub> mA	G <sub>pe</sub> dB Min	NF dB Max	@ f   MHz	I <sub>hfe1</sub> @ Min   f MHz	C <sub>obo</sub> pF Max
<b>NPN</b>								
TO-206AF	2N918	15	20   3	15	6	60	6   100	1.7
<b>PNP</b>								
TO-206AF	2N4261	15	30   10	—	—	—	15   100	2.5

**Table 6. Switching Transistors**

The following devices are intended primarily for use in general-purpose switching, but can be used in amplifier and driver applications. Within each package group shown, the devices are listed in order of decreasing turn-on time (t<sub>on</sub>).

Package	Device Number	t <sub>on</sub> ns Max	t <sub>off</sub> ns Max	@ I <sub>C</sub> mA	V(BR)CEO Volts Min	I <sub>C</sub> mA Max	hFE @ Min   Max   I <sub>C</sub> mA	V <sub>CE(sat)</sub> Volts Max	@ I <sub>C</sub> mA	I <sub>B</sub> mA
<b>NPN</b>										
TO-206AA	2N914	40	40	200	15	150	30   120	10	0.3	10   1
	2N708	40	75	10	15	—	40   120	10	0.4	10   1
	2N3013	15	25	300	20	300	35   120	30	0.18	30   3
	2N2369A	12	18	10	15	200	40   120	10	0.2	10   1
TO-205AD	2N3735	—	60	1000	50	1500	20   80	1000	0.9	1000   100
	2N3506	30*	35*	1500	40	3000	40   200	1500	1	1500   150
	2N3507	30*	35*	1500	50	3000	30   150	1500	1	1500   150
	2N3737	—	60	1000	50	1500	20   80	1000	0.9	1000   100
TO-206AB	2N4449	12	18	10	15	200	40   120	10	0.2	10   1
<b>PNP</b>										
TO-206AA	2N869A	50	80	30	18	200	40   120	10	0.15	10   1
TO-205AD	2N3634	400	600	50	140	1000	50   150	50	0.6	50   5
	2N3635	400	600	50	140	1000	100   300	50	0.6	50   5
	2N3636	400	600	50	175	1000	50   150	50	0.6	50   5
	2N3637	400	600	50	175	1000	100   300	50	0.6	50   5
	2N4033	25*	35*	500	80	1000	100   300	100	0.15	150   15
	2N3467	30*	30*	500	40	1000	40   120	500	0.6	500   50
2N4405	25*	50*	500	80	500	100   300	150	0.2	150   15	
TO-206AB	2N3764	35*	35*	1	40	1500	30   120	1000	0.9	1000   100

t<sub>r</sub>\*/4\*

6

**Table 7. High-Voltage/High-Current Transistors**

This following table lists Motorola standard devices that have high Collector-Emitter Breakdown Voltage. Devices are listed in decreasing order of  $V_{(BR)CEO}$  within each package type.

Package	Device Number	$V_{(BR)CEO}$ Volts Min	$I_C$ mA Max	$h_{FE}$ Min/Max	@   $I_C$ mA	$V_{CE(sat)}$ Volts Max	@   $I_C$ mA	&   $I_B$ mA
<b>NPN</b>								
TO-205AD	2N3439	350	1000	40/160	20	0.5	50	4
	2N3440	250	1000	40/160	20	0.5	50	4
	2N3501	150	300	100/300	150	0.4	150	15
<b>PNP</b>								
TO-205AD	2N5416S	350	1000	30/120	50	2	50	5
	2N3743	300	50	50/200	30	1.2	30	3
	2N4931	250	50	50/200	30	1.2	30	3
	2N3637	175	1000	100/300	50	0.6	50	5
	2N3636	175	1000	50/150	50	0.6	50	5
	2N3635	140	1000	100/300	50	0.6	50	5
	2N3634	140	1000	50/150	50	0.6	50	5

**Table 8. Multiple Transistors**

These multiple small-signal transistors include devices intended for amplifier and switching applications.

Device Number	Maximum Ratings			Electrical Characteristics						
	$V_{CEO}$ V	$I_C$ mA	$P_D(Total)$ W	$I_{CBO}$ $\mu A$ Max	$h_{FE}$ Min/Max	@   $I_C$ mA	$V_{CE(sat)}$ Volts Min	@   $I_C$ mA	&   $I_B$ mA	
<b>QUAD — NPN</b>										
<b>Case 632-02</b>										
2N6989	50	800	1.5	0.01	100/300	150	0.3	150	15	
<b>Case 607-04</b>										
2N6990	50	800	0.4	0.01	100/300	150	0.3	150	15	
<b>QUAD — PNP</b>										
<b>Case 632-02</b>										
2N6987	60	600	1.5	0.01	100/300	150	0.4	150	15	
<b>Case 607-04</b>										
2N6988	60	600	0.4	0.01	100/300	150	0.4	150	15	
<b>DUAL — NPN</b>										
<b>Case 654-07</b>										
2N2060	60	500	0.5	0.002	30/90	0.1	0.3	0.5	5	
2N3819	60	30	0.5	0.002	300/1000	0.1	0.3	1	0.1	
2N3820	60	30	0.5	0.002	150/600	0.1	0.3	1	0.1	
2N3810	60	50	0.6	0.01	150/450	0.1	0.2	0.1	0.1	
2N3811	60	50	0.6	0.01	300/900	0.1	0.2	0.1	0.1	
2N4854	40	600	0.6	0.01	100/300	150	0.4	150	15	
2N5794	40	600	0.6	0.01	100/300	150	0.6	150	15	
2N5796	60	600	0.6	0.02	100/300	150	0.4	150	15	

6

## JFETs

**Table 9. N-Channel — Amplifiers, TO-206AF**

Device	$ Y_{fs} $ ( $\mu\text{mho}$ ) @ $f$		$ Y_{os} $ ( $\mu\text{mho}$ ) @ $f$		$C_{iss}$ (pF) Max	$C_{rss}$ (pF) Max	NF (dB) @ $R_G=1\text{ M}\Omega$ $f$ (kHz)		$V_{(BR)}$ (V) Min	$V_{GS(off)}$ (V)		$I_{DSS}$ (mA)	
	Min	(kHz)	Min	(kHz)			Max			Min	Max	Min	Max
2N3821	1500	1	10	1	6	3	2.5	0.01	50	—	4	0.5	2.5
2N4416A	4500	1	50	1	4	0.8	4	400	35	2.5	6	5	15

**Table 10. N-Channel — Switches and Choppers, TO-206AA**

Device	$R_{DS(on)}$ ( $\Omega$ ) @ $I_D$		$V_{GS(off)}$ (V)		$I_{DSS}$ (mA)		$V_{(BR)}$ (V) Min	$C_{iss}$ (pF) Max	$C_{rss}$ (pF) Max	$t_{on}$ (ns) Max	$t_{off}$ (ns) Max
	Max	mA	Min	Max	Min	Max					
2N4856	25	0	4	10	50	—	40	18	8	6	25
2N4857	40	0	2	6	20	100	40	18	8	6	50
2N4858	60	0	0.8	4	8	80	40	18	8	10	100



# Mil-Processed Discrete Semiconductors

The wide range of component requirements for today's high-technology military and space applications often go beyond the available MIL-S-19500-specified component complement. Normally, these needs are met with devices manufactured and tested to a customer's high-reliability specifications developed specifically for these custom parts. The result — high initial cost and long delivery time.

To reduce both of these detriments, Motorola now offers a standard, inventoried line of popular discrete products for which no military specifications exist, but which have been processed to rigid MIL-S-19500 and MIL-STD-750 specifications, just as if they were built for JAN registration. Since no military slash sheets exist for these components, the electrical parameters are those applied to equivalent Motorola commercial products. Delta calculations, however, and Group B and C test limits, are selected with the same considerations as for MIL-S-19500 specifications.

Compared with custom equivalents, customers able to utilize these components will find significant savings in both cost and delivery time. Moreover, the life span of such devices will be considerably longer than that of custom-built "specials," so that replacements will be available for the foreseeable future.

## Parts Identification and Marking

For its packaged Military Processed Components, Motorola will use only hermetically sealed commercial products capable of being processed to MIL-S-19500 requirements. For identification, the products will have a prefix similar to those presently used for internal (non-EIA-registered) devices, e.g. MM, MHM, MRF, MCR, etc., followed by the standard EIA or internal part number, and special JAN equivalent suffixes. The suffixes, HX, HXV and HS signify testing to JANTX, JANTXV and JANS respectively.

MIL-Processed devices will be marked with the Motorola Logo, the in-house part number and a four digit date code. Should a DESC Drawing become available, the DESC Drawing part number will also be marked. Re-marking is not available, due to permanency of the marking.

Should fully qualified JAN equivalents become available, Motorola will discontinue the MIL-Processed Devices unless there is a technical problem with supplying the JAN qualified device. In such cases the MIL-Processed devices will be retained and a detailed list of variations from the JAN equivalent will be provided.

6

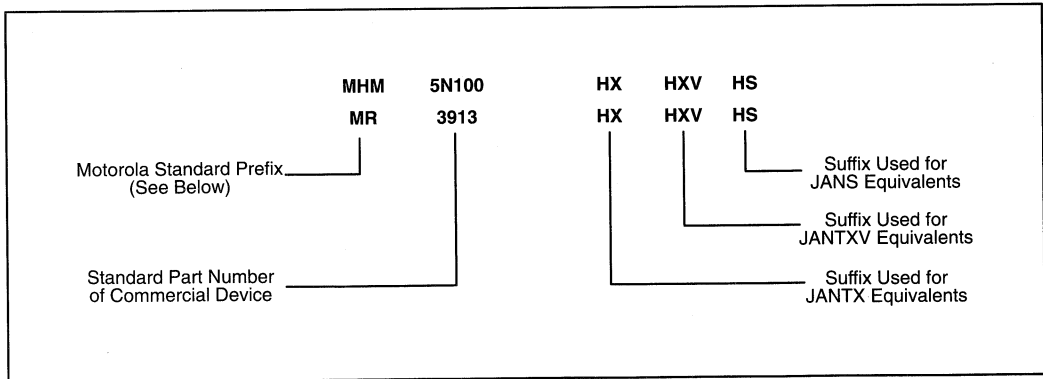

## Motorola Standard Prefixes

MBR — Rectifiers  
MCR — Thyristors  
MD — Dual Transistors (Bipolar)  
MHM, MHT — Transistors, TMOS  
MHQ — Quad Transistors (Bipolar)  
MJ — Transistors, Bipolar Power

MJM — Transistors, Bipolar Power, TO-254  
MR — Rectifiers  
MRF — Transistors, RF  
MUR — Rectifiers  
MMCM — Transistor, Surface Mount

**Table 11. JAN-Type Processing for Commercial Products**

MIL-Processed devices will receive the following screens, tests and inspections.

Processing	Specification	Lot
<b>HX Level, (JAN TX Equivalent) —</b>		
High Temperature Non-operating Life	MIL-STD-750, Method 1032	Optional
Temperature Cycle	MIL-STD-750, Method 1051	100%
Thermal Response when specified	MIL-STD-750, Method 3101-61	100%
Constant Acceleration	MIL-STD-750, Method 2006	Optional
Hermetic Seal		
Fine Leak, Condition G or H		
Gross Leak, Condition A, C, D, E or F	MIL-STD-750, Method 1071	100%
Interim Electrical Measurements	As Specified, when required	100%
High Temperature Reverse Bias Condition A	MIL-STD-750, Method 1039/9/42	
Interim Electrical Measurements	As specified, parameters as required	100%
Power Burn-in	MIL-STD-750, Method 1038/9/40/2	100%
Electrical Measurements, Delta Calculations	Parameters as Required	100%
Electrical Measurements	Subgroup A2 only	100%
Group A Inspection	MIL-S-19500	Sample
Group B Inspection	MIL-S-19500	Sample
Group C Inspection*	MIL-S-19500	Sample
<b>HXV Level, (JAN TXV Equivalent) —</b>		
Devices will receive all Level HX tests, plus Precap Visual Inspection	MIL-STD-750, Method 2069-74	100%
<b>HS Level, (JAN S Equivalent) —</b>		
Contact your Motorola Sales representative for processing details		

\* Group C inspection will be run on the initial lot only. Data will be retained for seven years.

## Power Transistors

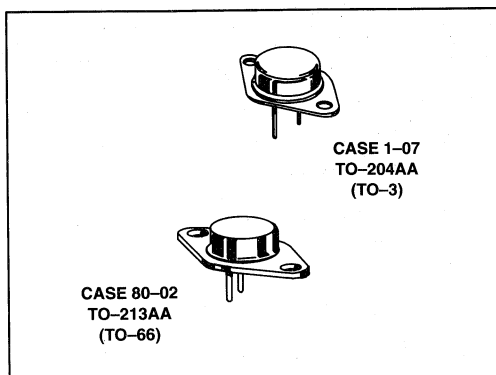

Table 12. Bipolar, Low Frequency

Device Number	Maximum Ratings			Electrical Characteristics					
	$V_{CE0}$ Adc	$I_C$ Adc	$P_D$ W	$h_{FE}$ Min/Max	@   $I_C$ mA	$t_r/t_f$ $\mu$ s Max	@   $I_C$ Adc	$V_{CE(sat)}$ Vdc Max	$f_T$ MHz Min
<b>TO-204AA/AE Package</b>									
<b>NPN</b>									
MJ10016HX, HXV	120	30	200	200/—	30	—	—	4	—
MJ11022HX, HXV	250	15	175	400/15000	10000	1.2/10	10	2	3
MJ11032HX, HXV	120	50	300	400/—	50	—	—	3.5	—
<b>PNP</b>									
MJ11021HX, HXV	250	15	175	400/15000	10000	1.2/10	10	2	3
MJ11033HX, HXV	120	50	300	400/—	50	—	—	3.5	—
<b>TO-213AA Package</b>									
<b>NPN</b>									
MJ6316HX, HXV	80	7	90	20/100	2.5	0.7/0.8	2.5	1	4
<b>PNP</b>									
MJ6318HX, HXV	80	7	90	20/100	2.5	0.7/0.8	2.5	1	4

6

## Small-Signal Transistors

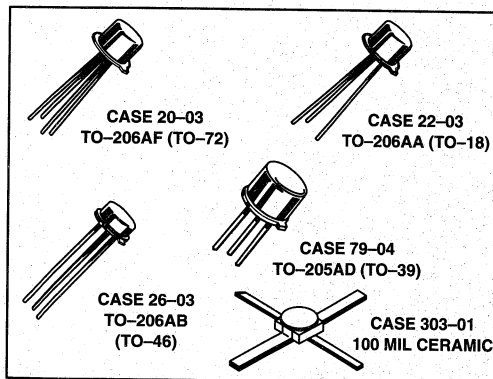

Table 13. Bipolar, RF

Device Number	Maximum Ratings			Electrical Characteristics								Package
	V <sub>CEO</sub> Vdc	I <sub>C</sub> mA	P <sub>D</sub> W	I <sub>CBO</sub> μAdc Max	h <sub>FE</sub> Min/Max	f <sub>T</sub> GHz @ I <sub>C</sub> Min/Max	I <sub>C</sub> mA	NF dB @ f Min/Max   MHz	G <sub>PE</sub> dB @ f Min/Max   MHz			
<b>NPN</b>												
MRF2857HX, HXV	15	40	0.3	—	30/150	—	3	-4.5	450	12.5/21	450	CASE 303-01
MRF5109HX, HXV	20	400	1	—	40/150	—	50	-3.5	200	11/-	200	CASE 205AD
MRF6603HX, HXV	15	30	0.3	—	30/200	—	15	1/2.5	1000	15/21	1000	CASE 303-01
MRF6604HXV	15	50	0.5	0.05	30/200	—	—	3	1000	15	1000	CASE 303-01
<b>PNP</b>												
MRF522HXV	10	50	—	10	25/125	—	0	3.5	1000	10	1000	CASE 303-01
MRF4957HX, HXV	30	30	0.2	0.1	30/165	1.2	2(I <sub>E</sub> )	3.5	450	17	450	TO-206AF
MRF5583HX, HXV	30	500	5	0.05	25/100	1	40	—	—	—	—	TO-205AD

6

Table 14. RF Transistor, Bipolar NPN Power, V<sub>CC</sub> = 28 Vdc

Device Number	Frequency MHz, Max	P <sub>OUT</sub> W	@	P <sub>IN</sub> W (Max)	η <sub>1</sub> G <sub>pe</sub> dB (Min)	Package
MRF3866AHX, HXV	400	1		0.15	45	79-04 (TO-39)

## Multiple Transistors

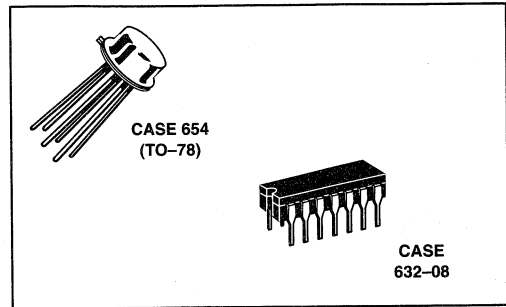

**Table 15. Bipolar**

Multiple transistors are multi-chip devices with two (duals) or four (quads) chips in a single package. The transistors are signal devices intended for switching and amplifier applications.

Device Number	Maximum Ratings			Electrical Characteristics						Package
	V <sub>CEO</sub> Vdc	I <sub>C</sub> mA	P <sub>D</sub> * W	I <sub>CBO</sub> μAdc Max	h <sub>FE</sub> Min/Max	@ I <sub>C</sub> mA	V <sub>CE(sat)</sub> Volts Max	@ I <sub>C</sub> mA	& I <sub>B</sub> mA	
<b>DUALS — NPN</b>										
MD2369AHX, HXV	15	200	0.36	0.02	40/120	10	0.02	10	1	654
MD918HX, HXV	15	50	0.2	0.01	20/200	3	0.4	10	1	654
<b>DUALS — PNP</b>										
MD3251AHX, HXV	60	50	0.625	0.02	100/300	10	0.25	10	1	654
MD3468HX, HXV	50	1000	0.65	0.1	25/75	500	0.3	150	15	654
<b>DUALS — NPN/PNP</b>										
MD6002HX, HXV	30	500	0.625	0.02	100/300	150	0.4	150	15	654
<b>QUADS — NPN</b>										
MHQ2484HX, HXV	60	50	2	0.005	200/500	0.01	0.3	1	0.1	632
MQ2484HXV	60	50	0.6	0.005	200/500	0.01	0.3	1	0.1	607
MHQ2369HX, HXV	15	500	1.5	0.2	40/120	10	0.2	10	1	632
MQ2369AHXV	15	500	0.6	0.2	40/120	10	0.2	10	1	607
MHQ918HX, HXV	15	50	1.6	0.01	20/200	3	0.4	10	1	632
MQ918HXV	15	50	0.4	0.01	20/200	3	0.4	10	1	607
<b>QUADS—PNP</b>										
MHQ3251AHX, HXV	60	200	1.5	0.02	100/300	10	0.25	10	1	632
MQ3251AHXV	60	200	0.6	0.02	100/300	10	0.25	10	1	607
MHQ3468HX, HXV	50	1000	2	0.1	25/75	500	0.35	150	15	632
MQ3468HXV	50	1000	0.6	0.1	25/75	500	0.35	150	15	607
<b>QUADS—NPN/PNP</b>										
MHQ6002HX, HXV*	30	500	1.9	0.02	100/300	150	0.4	150	15	632
MQ6002HXV	30	500	0.6	0.02	100/300	150	0.4	150	15	607

\* All die, equal power  
Available as DESC drawing 91010-01TX, TXV.

6

# Surface Mounted Devices

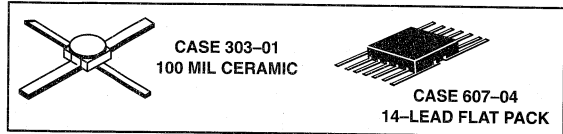
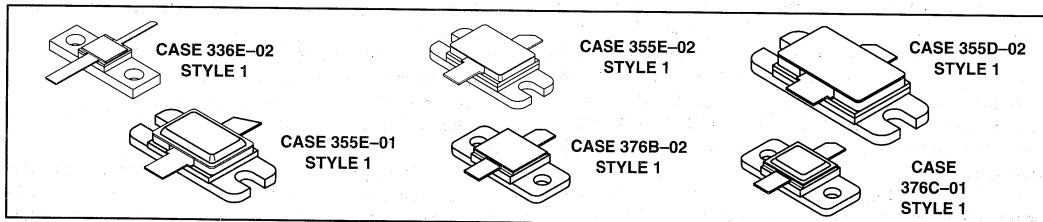

Table 16. Surface Mounted Devices

Device Number	Mark	V <sub>(BR)</sub> CEO V <sub>dc</sub>	h <sub>FE</sub>	I <sub>C</sub>
			Min/Max	(mA)
<b>RF Transistors (Case 303-01)</b>				
MRF522HXV	522	10	25/125	30
MRF6603HXV		15	30/200	15
MRF6604AHXV		15	30/200	30
<b>Small Signal Quad Transistors (Case 607-04)</b>				
MQ918HXV	NPN	15	20/200	3.0
MQ2369AHXV	NPN	15	40/120	10
MQ2484HXV	NPN	60	250/800	1.0
MQ2605HXV	PNP	60	150/450	0.5
MQ3251AHXV	PNP	60	100/300	10
MQ3468HXV	PNP	50	25/75	500
MQ6002HXV	NPN/PNP	30	100/300	100
2N6988JTXV	PNP	60	100/450	1.0
2N6990JTXV	NPN	50	75/325	1.0

## RF Power Devices



These products are designed for pulse power amplifier applications in the 960 to 1215 MHz frequency range. They are capable of handling up to 10 μs pulses in long trains resulting in up to a 50% duty cycle over 3.5 millisecond interval. Overall duty cycle is limited to 25% maximum. The primary application for devices of this type are military systems, specifically JTIDS and commercial systems, specifically Mode S. Package types are hermetic.

6

Table 17. L-Band Long Pulse Power

Device Number	P <sub>OUT</sub> Output Power Watts	P <sub>IN</sub> Input Power Watts	G <sub>PB(MIN)</sub> Gain @ 1215 MHz dB	R <sub>θJC</sub> °C/W	Package Style
<b>V<sub>CC</sub> = 28 Volts — Class C Common Base</b>					
MRF10005HX	5	0.71	8.5	8	336E-02/1
<b>V<sub>CC</sub> = 38 Volts — Class C Common Base</b>					
MRF10031HX	30	3	10	3	376B-02/1
MRF10120HX	120	19	8	0.6	355C-02/1
<b>V<sub>CC</sub> = 50 Volts</b>					
MRF10070HX	70	7	10 <sup>(9)</sup>	0.4	376C-01/1
MRF10150HX	150	15	10 <sup>(9)</sup>	0.25	376B-02/1
MRF10350HX	350	45	9 <sup>(9)</sup>	0.11	355E-01/1
MRF10500HX	500	56	9 <sup>(9)</sup>	0.12	355D-02/1

<sup>(9)</sup> Typical @ 1090 MHz

# Commercial Plus Technologies Operation Discrete Chips

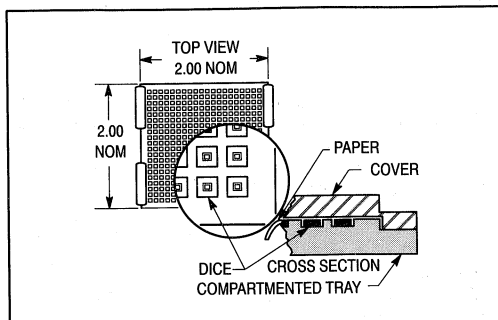

**Figure 3. MIL-tested discrete semiconductor chips are now available off the shelf for high reliability hybrid (multi-chip) circuits.**

Motorola's inventory of discrete products qualified to JAN, JANTX, JANTXV and JANS specifications currently covers many devices listed on the QPL. From these, and from key internal product lines Motorola has designated a comprehensive selection of components in unencapsulated (chi6.3-18p) form to undergo stringent military type testing in order to serve the needs of customers manufacturing hybrid circuits for military and other high reliability applications. The chips are carried in stock by Motorola and by a number of authorized chip resellers, thereby avoiding much of the delay and some of the cost associated with the development of custom products for special applications. The chip line encompasses some of the most popular part numbers from various product categories and is expected to satisfy a substantial portion of a hybrid manufacturer's discrete chip requirements.

Presently the proposed Revision H of MIL-S-19500 includes Appendix H, which identifies a new level of military device, the JAN C chip. The Motorola CPTO high reliability chips exceed the new JAN C chip. Since the JAN C device will be a standard, it will become the preferred chip for all military programs.

## Chip Identification

For identification, all Motorola MIL-tested chips will carry the part numbers of their encapsulated counterpart, except for the prefix. For EIA-registered devices, instead of the 1N or 2N prefixes the MIL-tested chips will be labelled 1C and 2C. For Motorola internal part numbers, the letter "C" will be added to the standard internal part number prefix.

Chips processed to JANTXV type specifications are further identified by the suffix "HV" added to the chip part number. Additional processing to JANS type specifications (suffix "HS") can be initiated routinely through advance communications with any Motorola sales office. Examples:

Standard Part Numbers	Equiv. MIL-Tested Part Numbers
2N2222A	2C2222AHV (or HS)
MZ2.4A	MZC2.4AHV (or HS)

## Chip Qualification

Chips to be used in defense, aerospace, beyond commercial and other high-reliability applications are tested to conform to the following military specifications where applicable:

- MIL-C-45662 Calibration System Requirements
- MIL-L-45208 Inspection System Requirements
- MIL-STD-750 Test Methods for Semiconductors

To qualify, individual chips are probe tested to guarantee conformance with the dc parameters corresponding to those on the military slash sheets. Parts not covered by military specifications will be tested to Motorola data sheet electricals and MIL-S-19500 will be used as a guide.

Table 57 describes the test capabilities for discrete chip probing.

Parameters which cannot be tested in probe will be tested on encapsulated devices on a sample basis for quality conformance. Table 58 details the tests performed on the chips, as well as those performed on encapsulated Lot Acceptance Test Samples (LATS).

**Table 18. Probe Test Capabilities**

Parameter	Test Conditions	Limits
Breakdown Voltages	10 $\mu$ A to 150 mA	0 to 2000 V
Leakage Currents	0 to 2000 V	10 nA to 175 mA
Current Gain (hFE)	100 $\mu$ A to 30 A	0 to 20 V
Saturation and "On" Voltages	100 $\mu$ A to 30 A	0 to 10V
Forward Voltages	0 to 30 A	0 to 10 V

6

**Table 19. JANTXV Process Flow for Motorola Discrete Military Products Chips**

Processing	Chips	LATS*
Electrical Probe, +25°C DC Only	100%	100%
Wafer Saw-Through	100%	100%
Visual Inspection MIL-STD-750, Method 2072 or 2073	100%	100%
Assemble in Applicable Package	—	See Table 3
In-Package Tests		
High Temperature Storage MIL-STD-750, Method 1032	—	100%
Hermetic Seal		
Fine and Gross Leaks MIL-STD-750, Method 1071	—	100%
Serialization	—	100%
Electrical Parameters		
Read and Record, Group A Only	—	100%
High Temperature Reverse Bias (HTRB)		
MIL-STD-750, Method 1039, Cond. A Transistors Only	—	100%
Delta Calculations for HTRB		
Read and Record	—	100%
Burn-In, High Power		
MIL-STD-750, Method 1039, Cond. B, Transistors Method 1038, Cond. B, Diodes	—	100%
Delta Calculations for Burn-In		
Read and Record	—	100%
Final Electrical Parameters		
Read and Record	—	100%
Bond Pull & Die Shear		
MIL-STD-750, Method 2017 & 2037	—	5 Devices

\* LATS = Lot Acceptance Test Samples.

**6**



## Lot Acceptance Criteria

For lot acceptance tests, transistor die will be mounted in applicable TO-18, TO-205AD (TO-39), TO-204AA/AE (TO-3) packages and zener diode chips will be mounted in TO-18 packages.

In cases where there are more than 2500 chips on a wafer, a lot will consist of only one wafer and sample chips to be used for packaged devices will be selected randomly and uniformly from across the wafer. For larger die, with less than 2500 chips per wafer, samples will be selected from more than one wafer and traceability will be to the wafer lot.

Table 59 lists the lot acceptance criteria for various size chips.

**Table 20. Lot Acceptance Criteria**

Average Number of Electrically Good Die Per Wafer	Minimum Sample Size	Limits
Over 2500	77	LTPD = 5 Acceptance No. C = 1
1000 to 2499	55	LTPD = 7 C = 1
2 to 999	38	LTPD = 10 C = 1

For devices with more than 2500 die per wafer, QCI will be performed on each wafer.

### Packaging

Motorola supplies all discrete semiconductor chips in the industry standard multi-pak. This is a 2" x 2" waffle type carrier with separate compartments for each die, Figure 3. The dice

are covered with filter papers aligned with the top edge of the tray. The multi-pak itself is conductive, or covered with conductive material, to reduce the danger of damage to the die from electro-static discharge. For die 30 mil square or smaller, there will be 400 chips in each waffle pack. For a progressively larger die, waffle packs with 100, 49 and 25 chip compartments will be used. The waffle pack will be enclosed in a dry nitrogen filled or vacuum packed conductive bag and each waffle pack will contain chips from only one wafer. All will contain the following information:

Motorola Logo  
 Device Part Number  
 Inspection Lot Number (Wafer Number)  
 Date Code (Assembly Date of the LATS)  
 ESD Symbol as applicable, per MIL-STD-1285

### Handling and Storage

When removing the cover from the waffle pack, the die may have a tendency to stick to the paper insert between the top cover and the tray. To resolve this problem, Figure 4, place the cover upside-down on the tray and apply light finger pressure to the cover. Then using tweezers, slide the paper from between the tray and the cover.

Chips should be stored at room temperature in an inert environment. Special electrostatic discharge (ESD) precautions should be taken to avoid chip damage. Storage in the original shipping package is recommended.

6

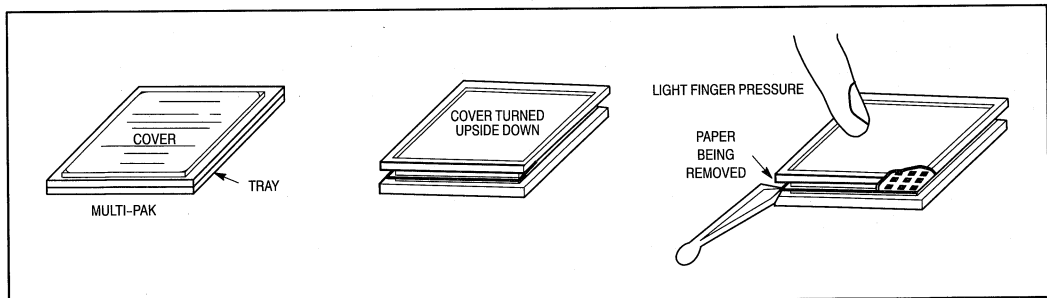

**Figure 4. Care in removing the filter paper from the multi-pak will prevent loss of chips adhering to the paper.**

# Selector Guide

The following tables list the various Motorola CPTO chips first by specific product categories and then in a logical fashion that permits rapid comparison of the more important design specifications.

**Table 21. Transistors**

**Power, Bipolar** — Listed in order of increasing Collector Current,  $I_C$

Device Number		$I_C$ A	$V_{CE(sus)}$ Vdc Min	$h_{FE}$ Min/Max	@ $I_C$ A	$t_{on}/t_{off}$ $\mu$ s Max	$t_r/t_f$ $\mu$ s Max	@ $I_C$ A	$h_{fe}$ Min/Max	@ f MHz
NPN	PNP									
2C3767HV		4	80	40/60	0.5	0.25/2.5	—	0.5	1/8	10
	2C3741HV	4	80	30/120	0.25	0.4/1	—	1	25/250	0.001
2C5339HV	2C6193HV	5	100	60/240	2	—	0.1/0.2	2	3/15	10
2C3716HV	2C3792HV	10	80	30/120	3	—	1.3*	5	30/300	0.001
2C6059HV	2C6052HV	12	100	75/18k	6	2/10	—	5	1000/—	0.001

\* $t_r = 1.2 \mu$ s for 2C3716;  $1.0 \mu$ s for 2C3792

**Small-Signal** — Listed in order of decreasing Breakdown Voltage,  $V_{(BR)CEO}$

Device Type	$V_{(BR)CEO}$ Volts Min	$I_C$ mA Max	$h_{FE}$ Min/Max	@ $I_C$ mA	$V_{CE(sat)}$		$t_{on}/t_{of}$		$h_{fe}$ Min/Max	@ f MHz
					Volts Max	@ $I_C/I_B$ mA	ns Max	@ $I_C$ mA		

**NPN**

2C3439HV	350	1000	40/60	20	0.5	50/4	1/10**	20	3/15	5
2C3501HV	150	300	100/300	150	0.4	150/15	115/1150	15	1.5/8	100
2C3019HV	80	1000	100/300	150	0.2	150/15	30/30	—	5/20	20
2C2484HV	60	50	200/500	0.01	0.3	1/0.1	—	—	2/7	30
2C2222AHV	50	800	100/300	150	1	500/50	35/300	150	2.5/—	100
2C2369AHV	40	200	40/120	10	0.2	10/1	16-Dec	10	5/10	100
2C918HV	15	50	20/200	3	0.4	10/1	—	—	6/18	100

**PNP**

2C3251AHV	60	200	100/300	10	0.25	10/1	35/50*	10	3/9	0.1
2C2907AHV	60	50	100/300	150	0.4	150/15	45/300	—	2/—	100
2C2605HV	60	30	100/300	0.01	0.3	10/0.5	—	—	1/8	30
2C3468HV	50	1000	25/75	500	0.35	150/15	30/30*	500	150/500***	100

\* =  $t_r/t_f$  \*\* =  $\mu$ s \*\*\* =  $t_T$

**RF, Power**

Device Type	$V_{(BR)CEO}$ Volts Min	$I_C$ mA Max	$P_{out}$		$P_{in}$ W	f MHz	$h_{FE}$ Min/Max	@ $I_C$ mA	$h_{fe}$ Min/Max	@ f MHz
			W	@ f MHz						

**NPN**

2C3553HV	40	1000	2.5/5.0	0.25	175	15/150	150	3.5/—	100
2C3866AHV	30	400	1.0/2.0	0.15	400	25/200	50	4/7.5	200

6

**Table 21. Transistors (continued)**  
RF, Small-Signal

Device Type	V <sub>(BR)CEO</sub> Volts Min	I <sub>C</sub> mA Max	G <sub>pe</sub> dB Min/Max	@ f MHz	Noise Figure		h <sub>FE</sub> Min/Max	I <sub>C</sub> mA	h <sub>fe</sub> Min/Max	@ f MHz
					dB Max	@ f MHz				
<b>NPN</b>										
2C5109HV	20	400	11/—	200	3.5	200	40/150	50	5/10	200
2C2857HV	15	40	12.5/21	450	4.5	450	30/150	3	19-Oct	100

**Table 22. Zener Diodes**

Device Type		V <sub>Z</sub> Vdc ±5%
Registered	Internal	
1C4370AHV	MZC2.4A5HV	2.4
	MZC2.5A5HV	2.5
1C4371AHV	MZC2.7A5HV	2.7
	MZC2.8A5HV	2.8
1C4372AHV	MZC3.0A5HV	3
1C746AHV	MZC3.3A5HV	3.3
1C747AHV	MZC3.6A5HV	3.6
1C748AHV	MZC3.9A5HV	3.9
1C749AHV	MZC4.3A5HV	4.3
1C750AHV	MZC4.7A5HV	4.7
1C751AHV	MZC5.1A5HCV	5.1
1C752AHV	MZC5.6A5HV	5.6
	MZC6.0A5HV	6
1C753AHV	MZC6.2A5HV	6.2
1C754AHV	MZC6.8A5HV	6.8
1C755AHV	MZC7.5A5HV	7.5
1C756AHV	MZC8.2A5HV	8.2
	MZC8.7A5HV	8.7
1C757AHV	MZC9.1A5HV	9.1
1C758AHV	MZC10A5HV	10
1C962BHV	MZC11A5HV	11
1C759AHV	MZC12A5HV	12
1C964BHV	MZC13A5HV	13
	MZC14A5HV	14
1C965BHV	MZC15A5HV	15
1C966BHV	MZC16A5HV	16
	MZC17A5HV	17
1C967BHV	MZC18A5HV	18
	MZC19A5HV	19
1C968BHV	MZC20A5HV	20
1C969BHV	MZC22A5HV	22

Device Type		V <sub>Z</sub> Vdc ±5%
Registered	Internal	
1C970BHV	MZC24A5HV	24
	MZC25A5HV	25
1C971BHV	MZC27A5HV	27
	MZC28A5HV	28
1C972BHV	MZC30A5HV	30
1C973BHV	MZC33A5HV	33
1C974BHV	MZC36A5HV	36
1C975BHV	MZC39A5HV	39
1C976BHV	MZC43A5HV	43
1C977BHV	MZC47A5HV	47
1C978BHV	MZC51A5HV	51
1C979BHV	MZC56A5HV	56
	MZC60A5HV	60
1C980BHV	MZC62A5HV	62
1C981BHV	MZC68A5HV	68
1C982BHV	MZC75A5H	75
1C983BHV	MZC82A5HV	82
	MZC87A5HV	87
1C984BHV	MZC91A5HV	91
1C985BHV	MZC100A5HV	100
1C986BHV	MZC110A5HV	110
1C987BHV	MZC120A5HV	120
1C988BHV	MZC130A5HV	130
	MZC140A5HV	140
1C989BHV	MZC150A5HB	150
1C990BHV	MZC160A5HV	160
	MZC170A5HV	170
1C991BHV	MZC180A5HV	180
	MZC190A5HV	190
1C992BHV	MZC200A5HV	200

6

# CPTO International Products

---

## In Brief . . .

It is the policy of MOTOROLA Semiconductor Products Sector to produce products and provide services exactly according to CUSTOMER expectations. This is known as Total Customer Satisfaction and it is our definition of quality. The program to achieve Total Customer Satisfaction is called SIX SIGMA. When our performance reaches a 6 Sigma level then our products and services will be virtually error free.

It is a corporate policy of MOTOROLA that all facilities must be qualified to the appropriate level of ISO 9000 which is the only internationally recognized standard for Quality Systems. Facilities which have full design and manufacturing capability are qualified to ISO 9001.

	<b>Page</b>
Reliability	6.4-2
Factory Qualifications	6.4-2
CECC 90 000 Screening Flow	6.4-2
CECC 50 000 Screening Flow	6.4-3
CECC Process Flow	6.4-3
Warranty/Rewarranty	6.4-3
T Series Flows	6.4-4
Warranty/Rewarranty	6.4-4
Microprocessors	6.4-5
Part Number Ordering Information	6.4-5
Marking Information	6.4-6
16- and 32-Bit Microprocessors	6.4-8
Microcontrollers	6.4-9
Reduced Instruction Set Computers (RISC)	6.4-10
Digital Signal Processors (DSP)	6.4-10
Logic, Analog and Special Functions	6.4-11
Part Number Ordering Information	6.4-11
Marking Information	6.4-13
CMOS Logic	6.4-15
High Speed CMOS (HCMOS) Logic	6.4-17
Advanced Schottky TTL (FAST) Logic	6.4-19
Low Power Schottky (LS) TTL	6.4-20
Advanced CMOS Technology	6.4-23
Analog Functions	6.4-24
Discretes	6.4-27
Part Number Ordering Information	6.4-27
Marking Information	6.4-27
Transistors	6.4-28
CECC Qualified	6.4-28
ESA/SCCG Qualified	6.4-28
CECC Processed	6.4-29
Diodes/Rectifiers	6.4-31
CECC Processed	6.4-31

6

# Reliability

Reliability is the ability of a product to function for a time period which is adequate to the purpose for which the component is used. It is normally expressed as a number of failures per component hour at a defined confidence level. (e.g. 0.002%/1000 hours at 95% confidence.) Reliability is not a constant with time and it is realized in the classical "bathtub curve."

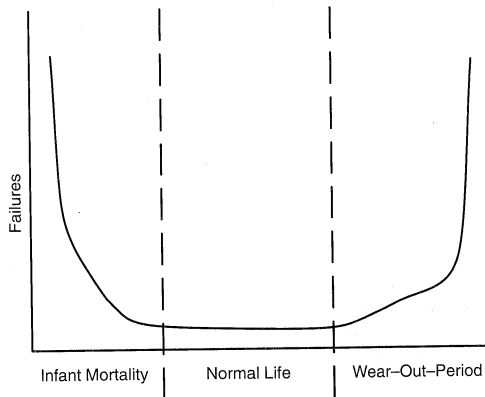

In the first (Infant Mortality) period Reliability improves with time. This period may last from one or two hours to several hundred hours. With most semiconductor products it is substantially completed in 100–150 hours. In the Normal life period Reliability is constant and failures are random and in the Wear out period Reliability decreases. It must be stressed that this is a theoretical curve and in spite of many millions of hours of testing and usage empirical evidence concerning the wear-out stage is minimal. The purpose of 100% screening is to eliminate the infant failures and operational sample Life Testing in CECC Groups B C and D provides a measure of early life reliability. Additionally MOTOROLA performs extensive accelerated stress tests on all product families on a continuous basis.

Good quality implies a well controlled manufacturing process which also contributes to product reliability. Consequently the MOTOROLA commitment to SPC and 6-Sigma quality benefits the reliability of all the products listed in this handbook.

## Factory Qualifications

- U.K.** MOTOROLA in East Kilbride, Scotland is responsible for Microprocessor and Memory products. The facility is qualified to ISO9001 and CECC 90 000 and is currently working on the qualification of a microprocessor to ESA requirements.
- France** MOTOROLA in Toulouse is the center for Logic, and Analog Integrated circuits and for Discrete semiconductor products. This facility is also qualified to ISO9001, CECC 50 000 and CECC 90 000 and holds device qualifications under the requirements of ESA/SCC.
- Germany** MOTOROLA in Munich is the center for ASIC design, and is also qualified to ISO9001

6

**Table 1. CECC 90 000 Class B Screening Flows for Integrated Circuits**

Internal Visual Examination
Storage at High Temperature — 24 hours @ max Storage temperature
Change of Temperature 10 cycles from maximum to minimum Storage temperature
Acceleration Steady State — 294 000 m/s <sup>2</sup> in direction Y2
Sealing
Fine Leak (1 x 10 <sup>-8</sup> Pa. m <sup>3</sup> /s) and Gross Leak
Electrical Tests (Pre Burn-In)
Burn-In — 168 hours at T <sub>amb</sub> = 125°C
Electrical Tests (Post Burn-In)
Final Electrical Tests
External Visual Examination

**Table 2. CECC 50 000 Screening Flows for Discretes**

Step	CECC 50000 Qualified		CECC 50000 Processed	
	A	B	A	B
Test Sequence				
Visual Inspection	100%	—	100%	—
Stabilization Bake	100%	100%	100%	100%
Temperature Cycle	100%	100%	100%	100%
Constant Acceleration	100%	100%	100%	100%
Hermeticity	100%	100%	100%	100%
Electrical Test (Pre Burn-In)	100%	100%	100%	100%
Burn-In	100%	100%	100%	100%
Electrical Test (Post Burn-In)	100%	100%	100%	100%
Tests (Group A)	Sample	Sample	Sample	—
(Group B)	Sample	Sample	—	—
(Group C)	Sample	—	—	—
Certification	CECC	CECC	Motorola	Motorola

**Table 3. CECC Processing Flows**

	Integrated Circuits	Discrete Product
Generic Standards	CECC 90000 CECC 90100 CECC 90200	CECC 50000
Test Methods	IEC 68 AND 147	IEC 68 AND 147
Detail Specifications	CECC 90103-XXX CECC 90104-XXX CECC 90107-XXX CECC 90109-XXX CECC 90110-XXX CECC 90116-XXX CECC 90201-XXX CECC 90202-XXX CECC 90301-XXX CECC 90302-XXX	CECC 5000X-XXX
Quality Assessment	as per CECC 90000	as per CECC 50000
Screening	Level B of CECC 90000*	CECC 50000 Sequence A and B and Full Assessment (N)

Manufactured under O.N.S. surveillance. In all cases a Certificate of Conformity is supplied.  
\* Other screening levels may be supplied. Consult the regional sales office for further details.

**6**

## Warranty and Rewarranty

CECC qualification imposes standards and geographical limits on the warranty period of product families. For both CECC 50000 and CECC 90000 (all levels and screening classes) the conditions are as follows:

Warranty — 24 months commencing from the date code on the product

Rewarranty — 24 months after the rewarranty date given in the Certificate of Conformance

**It is MOTOROLA policy to apply the same rules to processed parts as it is to formally qualified ones.**

# T Series Flows

(for Microprocessors only)

Motorola has introduced some microprocessors in -55 to +125 °C and -40 to +85 °C versions. The microprocessors are 68020, 68882, 68000, and the 68HC000. The screening flow is carried out as per the chart given below. These flows are called "T" flows.

Note: All new products to be qualified in CECC versions will also be introduced in our commercial plus flows. New "Commercial Plus Flows" will replace T flows for new product introduction.

## Flow Chart

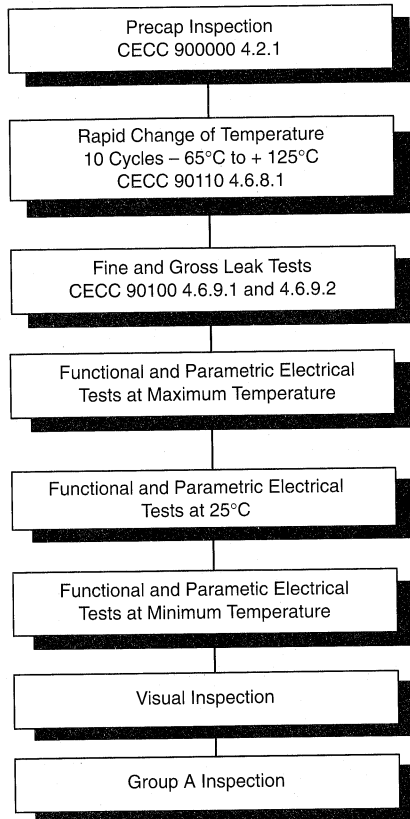

6

## Warranty and Rewarranty

CECC qualification imposes standards and geographical limits on the warranty period of product families. For both CECC 50000 and CECC 90000 (all levels and screening classes) the conditions are as follows:

Warranty — 24 months commencing from the date code on the product

Rewarranty — 24 months after the rewarranty date given in the Certificate of Conformance

**It is MOTOROLA policy to apply the same rules to processed parts as it is to formally qualified ones.**

# Microprocessors

## Part Number Ordering Information

CECC Qualified Products		68000 X nn / X X X X X					
Device Code	_____						
Temperature Range	C: $-55 < T_C < +125^{\circ}\text{C}$ _____						
Maximum Frequency (MHz)	_____						
Separator	_____						
Assessment Level	Y: level Y _____						
Screening Class	B: class B _____						
Package	R: PGA S: CLCC (Leaded) D: DIL _____						
Package Material	C: Ceramic _____						
Lead Finish*	C: Gold A: Hot solder dip B: Lead-tin plate _____						
Wafer Type	E: Epitaxial No Suffix: Non-epitaxial _____						
<small>Example of microprocessor device title — 68020C20/YBRCC            * NOTE: Microprocessor devices are normally supplied with Gold plated leads. Contact your Sales or Marketing representative to check the availability of other lead finishes.</small>							
T Flows		T 68000 X X X nn H					
T Flow Indicator	_____						
Device Code	_____						
Temperature Range	C: $-55 < T_C < +125^{\circ}\text{C}$ _____ A: $-40 < T_C < +85^{\circ}\text{C}$ _____						
Package Lead Finish*	R: PGA S: CLCC (Leaded) D: DIL _____ C: Gold A: Hot solder dip _____ B: Lead-tin plate _____						
Maximum Frequency (MHz)	_____						
Hi-Rel Indicator	_____						

6



# Marking Information

## Marking style for qualified CECC Pin Grid Array packages

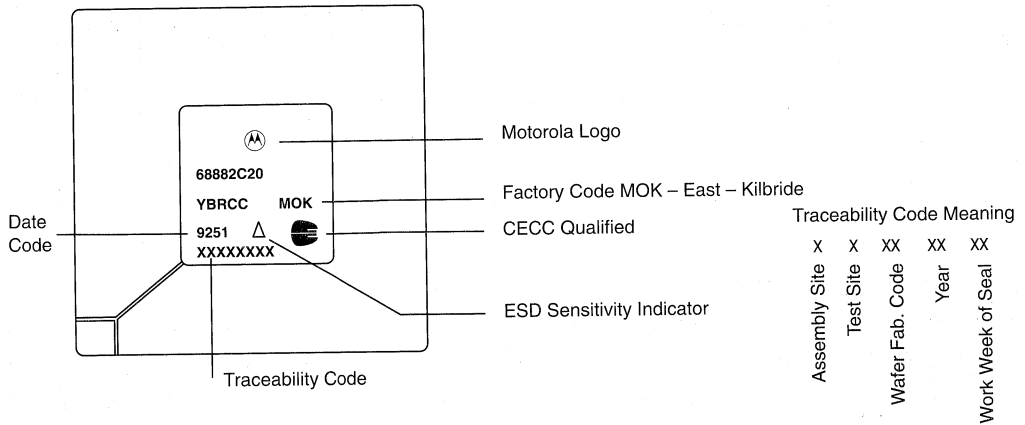

## Marking style for qualified T Flow Pin Grid Array packages

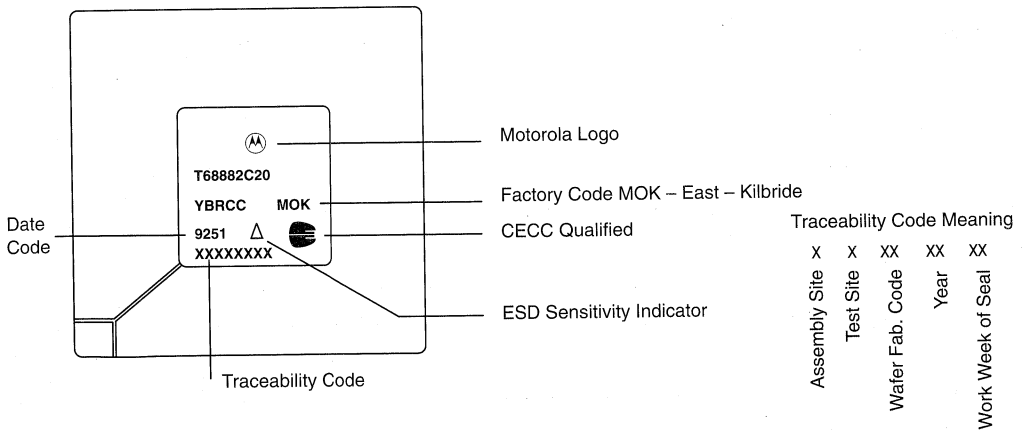

6

## Marking Information (continued)

### Marking style for qualified Ceramic Leaded Chip Carrier (CLCC) packages

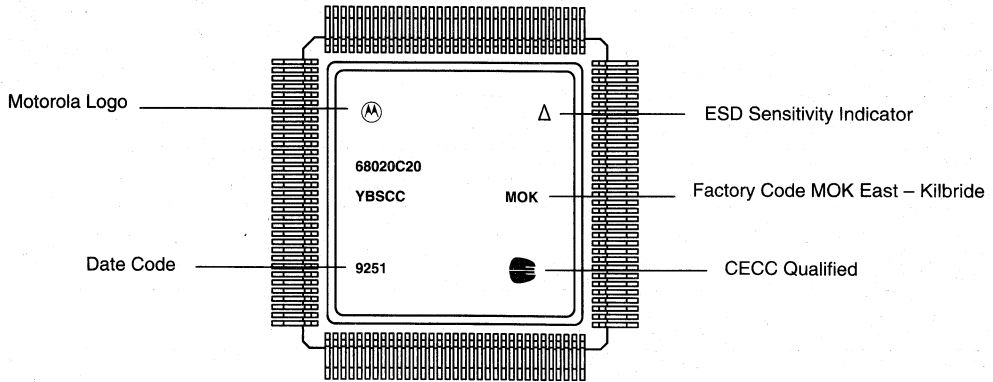

### Marking style for qualified Dual-In-Line (DIL) packages

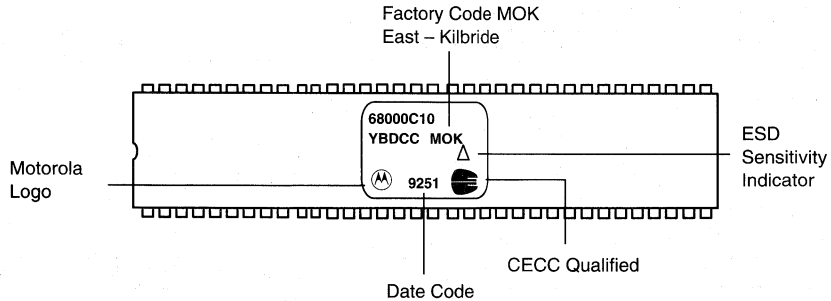

6

## 16- and 32-Bit Microprocessors

**Table 4. 68000 16-Bit Microprocessor**

Device	Frequency	Package	Production	Specification
68000C8/YBDCC	8 MHz	64 DIL	Now	CECC 90110-001
68000C8/YBRCC	8 MHz	68 PGA	Now	CECC 90110-001
68000C10/YBDCC	10 MHz	64 DIL	Now	CECC 90110-001
68000C10/YBRCC	10 MHz	68 PGA	Now	CECC 90110-001

**Table 5. T68000 16-Bit Microprocessor**

Device	Frequency	Package	Production	Temperature Range
T68000ADCXH	8, 10, 12 MHz	64 DIL	Now	- 40 to + 85 °C
T68000CDCXH	8, 10, 12 MHz	68 DIL	Now	- 55 to + 125 °C
T68000ARCXH	8, 10, 12 MHz	64 PGA	Now	- 40 to + 85 °C
T68000CRCXH	8, 10, 12 MHz	68 PGA	Now	- 55 to + 125 °C

**Table 6. 68HC000 16-Bit HCMOS Microprocessor**

Device	Frequency	Package	Production	Specification
68HC000C8/YBDCC	8 MHz	64 DIL	Now	CECC 90110-007
68HC000C8/YBRCC	8 MHz	68 PGA	Now	CECC 90110-007
68HC000C10/YBDCC	10 MHz	64 DIL	Now	CECC 90110-007
68HC000C10/YBRCC	10 MHz	68 PGA	Now	CECC 90110-007
68HC000C12/YBDCC	12 MHz	64 DIL	Now	CECC 90110-007
68HC000C12/YBRCC	12 MHz	68 PGA	Now	CECC 90110-007

**Table 7. T68HC000 16-Bit HCMOS Microprocessor**

Device	Frequency	Package	Production	Temperature Range
T68HC000ADCXH	8, 10, 12 MHz	64 DIL	Now	- 40 to + 85 °C
T68HC000CDCXH	8, 10, 12 MHz	68 DIL	Now	- 55 to + 125 °C
T68HC000ARCXH	8, 10, 12 MHz	64 PGA	Now	- 40 to + 85 °C
T68HC000CRCXH	8, 10, 12 MHz	68 PGA	Now	- 55 to + 125 °C

Microprocessor devices are normally supplied with Gold plated leads. Contact your Sales or Marketing representative to check the availability of other lead finishes.

6

**Table 8. 68020 32-Bit Microprocessor**

Device	Frequency	Package	Production	Specification
68020C16/YBRCC	16, 67 MHz	114 PGA	Now	CECC 90110-004
68020C16/YBSCC	16, 67 MHz	132 CLCC	Now	CECC 90110-004
68020C20/YBRCC	20 MHz	114 PGA	Now	CECC 90110-004
68020C20/YBSCC	20 MHz	132 CLCC	Now	CECC 90110-004
68020C25/YBRCC	25 MHz	114 PGA	Now	CECC 90110-004
68020C25/YBSCC	25 MHz	132 CLCC	Now	CECC 90110-004

**Table 9. T68020 32-Bit Microprocessor**

Device	Frequency	Package	Production	Temperature Range
T68020ARCXH	16, 20, 25 MHz	114 PGA	Now	- 40 to + 85 °C
T68020CRCXH	16, 20, 25 MHz	114 PGA	Now	- 55 to + 125 °C
T68020ASCXH	16, 20, 25 MHz	132 CLCC	Now	- 40 to + 85 °C
T68020CSCXH	16, 20, 25 MHz	132 CLCC	Now	- 55 to + 125 °C

**Table 10. 68040 32-Bit Microprocessor with MMU & FPU**

Device	Frequency	Package	Production	Specification
68040C25/YBRCC	25 MHz	179 PGA	1Q94	CECC 90110-XXX
68040C25/YBSCC	25 MHz	196 CLCC	1Q94	CECC 90110-XXX

Microprocessor devices are normally supplied with Gold plated leads. Contact your Sales or Marketing representative to check the availability of other lead finishes.

The microprocessors listed below can be considered for qualification depending on customer request:

68EC040-25, 68040 without the floating Point and Memory Management units in PGA and CLCC packages.

68LC040-25, 68040 without the floating Point and Memory Management units in PGA and CLCC packages.

## Microcontrollers

The Microcontrollers listed in this section can be considered for CECC qualification based on customer requests.

**Table 11. 68302 8/16-Bit Microcontroller Communication Oriented**

Device	Frequency	Package
68302C16/YBRCC	16 MHz	132 PGA
68302C16/YBSCC	16 MHz	132 CLCC

The microprocessors listed below can be considered for CECC qualification based on customer request:

68332-16 32-bit microcontroller with time processor unit in PGA or CLCC package

68340-16 32-bit microcontroller with DMA in PGA package

68F333-16 32-bit microcontroller with time processor unit and Flash EEPROM in PGA or CLCC package.

**Table 12. 68332 32-Bit Microcontroller with Time Processor**

Device	Frequency	Package
68332C16/YBRCC	16, 67 MHz	132 PGA
68332C16/YBSCC	16, 67 MHz	132 CLCC

**Table 13. 68882 Floating Point Coprocessor**

Device	Frequency	Package	Production	Specification
68882C16/YBRCC	16, 67 MHz	68 PGA	Now	CECC 90110-024
68882C16/YBSCC	16, 67 MHz	68 CLCC	Now	CECC 90110-024
68882C20/YBRCC	20 MHz	68 PGA	Now	CECC 90110-024
68882C20/YBSCC	20 MHz	68 CLCC	Now	CECC 90110-024
68882C25/YBRCC	25 MHz	68 PGA	Now	CECC 90110-024
68882C25/YBSCC	25 MHz	68 CLCC	Now	CECC 90110-024

6

**Table 14. T68882**

Device	Frequency	Package	Production	Temperature Range
T68882ARCXH	16, 20, 25 MHz	68 PGA	Now	- 40 to + 85 °C
T68882CRCXH	16, 20, 25 MHz	68 PGA	Now	- 55 to + 125 °C
T68882ASCXH	16, 20, 25 MHz	68 CLCC	Now	- 40 to + 85 °C
T68882CSCXH	16, 20, 25 MHz	68 CLCC	Now	- 55 to + 125 °C

Microprocessor devices are normally supplied with Gold plated leads. Contact your Sales or Marketing representative to check the availability of other lead finishes.

## Reduced Instruction Set Computers (RISC)

The devices listed in this section can be considered for CECC qualification based on customer requests.

**Table 15. 88100 32–Bit RISC Microprocessor**

Device	Frequency	Package
88100C20/YBRCC	20 MHz	180 PGA
88100C20/YBSCC	20 MHz	200 CLCC

**Table 16. 88200 16K Cache & Memory Management Unit**

Device	Frequency	Package
88200C20/YBRCC	20 MHz	180 PGA
88200C20/YBSCC	20 MHz	200 CLCC

## Digital Signal Processors (DSP)

The devices listed in this section can be considered for CECC qualification based on customer requests.

**Table 17. 56001 56–Bit DSP**

Device	Frequency	Package
56001C20/YBRCC	20 MHz	88 PGA
56001C20/YBSCC	20 MHz	100 CLCC

**Table 18. 96002 96–Bit FLOATING POINT DSP**

Device	Frequency	Package
96002C27/YBRCC	27 MHz	223 PGA
96002C27/YBSCC	27 MHz	CLCC

The devices listed below can be considered for CECC qualification based on customer requests:

56002 24–bit fixed point DSP in PGA or CLCC package at 33 and 40 MHz.

96002 32–bit floating point DSP in PGA package at 33 MHz.

6

# Logic, Analog and Special Functions

## Part Number Ordering Information

### CMOS Logic

**4002 X X / X X X X**

Device Code	_____	
Buffered	UB: Unbuffered    B: Buffered	_____
Temperature Range	F: $-55^{\circ}\text{C} < T_C < +125^{\circ}\text{C}$	_____
Assessment Level	R: level R	_____
Screening Class	B: class B	_____
Package	D: DIL	_____
Qualification Flag	Q: Qualified    P: Processed	_____

example of CMOS device title – **4001BF/RBDQ**

---

### HCMOS, TTL-FAST, TTL-LS Logic, CMOS FACT, and ANALOG FUNCTIONS

**54HC109 / X X X X X X**

Device Title (see example below)	_____	
Assessment Level	Y: level Y    N: Standard Assessment	_____
Screening Class	B: class B	_____
Package	D: DIL    C: T099    K: T03	_____
Package Material	G: Glass Ceramic    M: Metal Can	_____
Lead Finish	A: Hot solder dipped	_____
Qualification Flag	Q or Q2: Qualified    P: Processed	_____

example of HCMOS device title – **54HC109/YBDGAQ**  
 example of TTL – FAST device title – **54F109/YBDGAQ**  
 example of TTL – LS device title – **54LS109/YBDGAQ2**  
 example of ANALOG device title – **111/YBDGAQ**

## Part Number Ordering Information (continued)

### TTL-LS Logic

**54LS109 / X X X X**

Device Code \_\_\_\_\_

Assessment Level R: level R \_\_\_\_\_

Screening Class B: class B \_\_\_\_\_

Package D: DIL \_\_\_\_\_

Qualification Flag Q: Qualified P: Processed \_\_\_\_\_

example of TTL - LS device title - **54LS109/RBDQ**

**Note:** All the CECC qualified or processed integrated circuits in this section are currently in production unless otherwise stated. If you are unable to find your requirements for qualified Logic, Analog, or Special Function Integrated Circuits from the following pages, please contact your local Motorola Sales Office.

**6**

# Marking Information

## Marking style for qualified CMOS Dual-In-Line packages in the BS-CECC series

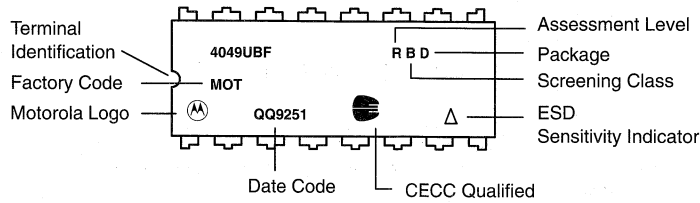

## Marking style for qualified TTL-LS Dual-In-Line packages in the BS-CECC series

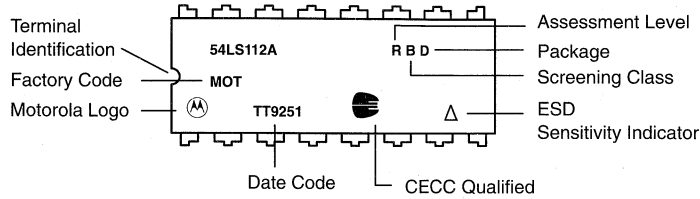

## Marking style for qualified TTL-LS Dual-In-Line packages UTE C 86212 series

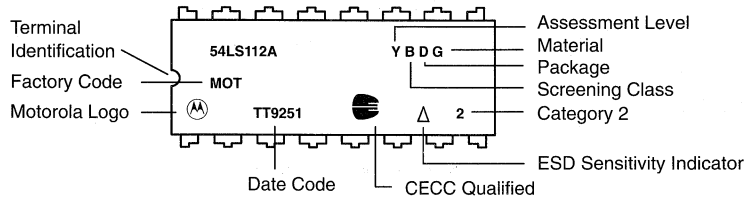

6

## Marking style for qualified HCMOS Dual-In-Line packages

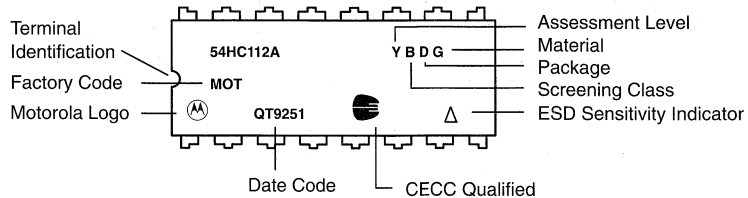



## Marking Information (continued)

### Marking style for qualified Analog Circuits

#### Ceramic 8 Pin Packages

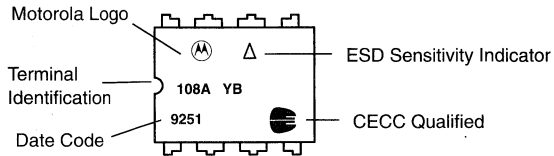

#### Metal Can Packages

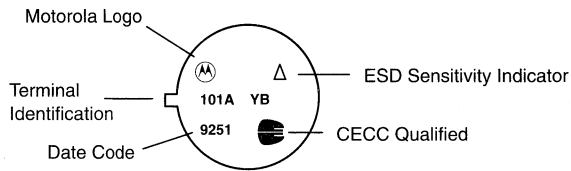

#### Ceramic 14 – 20 Pin Packages

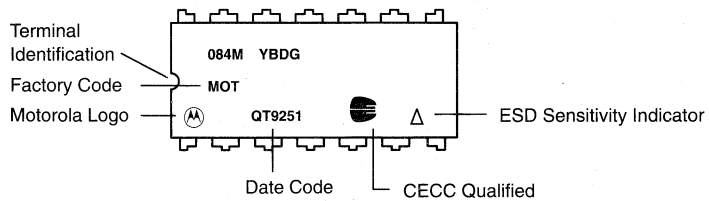

6

## CMOS Logic

**Table 19. CMOS Logic**

**Digital Logic Circuits in Dual-In-Line (DIL) Package**

Device	Specification	Description
4001BF/RBDQ	CECC 90104-105	NOR Gate, Quad 2-Input
4002BF/RBDQ	CECC 90104-106	NOR Gate, Dual 4-Input
4006BF/RBDQ	CECC 90104-107	Shift Register, 18-Bit Static
4008BF/RBDQ	CECC 90104-109	Adder, 4-Bit
4011BF/RBDQ	CECC 90104-110	NAND Gate, Quad 2-Input
4012BF/RBDQ	CECC 90104-111	NAND Gate, Dual 4-Input
4013BF/RBDQ	CECC 90104-112	Flip-Flop, Dual D Type
4014BF/RBDQ	CECC 90104-113	Shift Register, 8-Bit Static
4015BF/RBDQ	CECC 90104-114	Shift Register, Dual 4-Bit Static
4016BF/RBDQ	CECC 90104-115	Analogue Switch, Quad
4017BF/RBDQ	CECC 90104-170	Counter/Divider, Decade
4018BF/RBDQ	CECC 90104-171	Counter, Presettable Divide by N
4020BF/RBDQ	CECC 90104-116	Counter, 14-Bit Binary
4021BF/RBDQ	CECC 90104-117	Shift Register, 8-Bit Static
4022BF/RBDQ	CECC 90104-118	Counter/Divider, Octal
4023BF/RBDQ	CECC 90104-119	NAND Gate, Triple 3-Input
4024BF/RBDQ	CECC 90104-120	Counter, 7-stage Ripple
4025BF/RBDQ	CECC 90104-121	NOR Gate, Triple 3-Input
4027BF/RBDQ	CECC 90104-122	Flip-Flop, Dual J-K
4028BF/RBDQ	CECC 90104-123	Decoder, BCD to Decimal
4029BF/RBDQ	CECC 90104-124	Counter, 4-Bit Preset Up/Down
4032BF/RBDQ	CECC 90104-126	Adder, Triple Serial (Positive)
4035BF/RBDQ	CECC 90104-128	Shift Register, 4-stage
4040BF/RBDQ	CECC 90104-130	Counter, 12-Bit Binary
4042BF/RBDQ	CECC 90104-185	Latch, Quad
4043BF/RBDQ	CECC 90104-186	Latch, Quad NOR R-S
4044BF/RBDQ	CECC 90104-132	Latch, Quad NAND R-S
4046BF/RBDP	CECC 90104-212	Phase Locked Loop
4049UBF/RBDQ	CECC 90104-133	Inverter/Buffer, Hex
4050BF/RBDQ	CECC 90104-134	Buffer, Hex
4051BF/RBDQ	CECC 90104-135	Multiplexer, 8-Channel
4052BF/RBDQ	CECC 90104-136	Multiplexer, Dual 4-Input
4053BF/RBDQ	CECC 90104-137	Multiplexer, Triple 3-Channel
4060BF/RBDP	CECC 90104-213	Counter, 14-stage Binary
4066BF/RBDQ	CECC 90104-138	Bilateral Switch, Quad
4068BF/RBDQ	CECC 90104-139	NAND Gate, 8-Input
4069UBF/RBDQ	CECC 90104-140	Inverter/Buffer, Hex
4070BF/RBDQ	CECC 90104-187	Exclusive OR Gate, Quad
4071BF/RBDQ	CECC 90104-141	OR Gate, Quad 2-Input

**6**

**Table 19. CMOS Logic (continued)**

**Digital Logic Circuits in Dual-In-Line (DIL) Package**

Device	Specification	Description
4072BF/RBDQ	CECC 90104-142	OR Gate, Dual 4-Input
4073BF/RBDQ	CECC 90104-143	AND Gate, Triple 3-Input
4075BF/RBDQ	CECC 90104-144	OR Gate, Triple 3-Input
4076BF/RBDQ	CECC 90104-145	Register, Quad D type
4077BF/RBDQ	CECC 90104-146	Exclusive NOR Gate, Quad
4078BF/RBDQ	CECC 90104-147	NOR Gate, 8-Input
4081BF/RBDQ	CECC 90104-148	AND Gate, Quad 2-Input
4082BF/RBDQ	CECC 90104-149	AND Gate, Dual 4-Input
4093BF/RBDQ	CECC 90104-214	Schmitt Trigger, Quad 2-Input
4094BF/RBDQ	CECC 90104-188	Latch, 8-Bit Bus Compatible
4099BF/RBDQ	CECC 90104-150	Latch, 8-Bit Addressable
4161BF/RBDQ	CECC 90104-190	Counter, Binary
4174BF/RBDQ	CECC 90104-193	Flip-Flop, Hex D type
4175BF/RBDQ	CECC 90104-173	Flip-Flop, Quad D type
4490BF/RBDQ	CECC 90104-174	Contact Bounce Elim., Hex
4501UBF/RBDQ	CECC 90104-151	Gate, Triple
4502BF/RBDQ	CECC 90104-152	Inverter/Buffer, Strobe Hex
4503BF/RBDQ	CECC 90104-175	Buffer, Hex 3-State
4504BF/RBDP	CECC 90104-215	Level Shifter, Hex TTL or CMOS
4506UBF/RBDQ	CECC 90104-154	AOI Gate, Dual Expandable
4510BF/RBDQ	CECC 90104-156	Counter, BCD Up/Down
4511BF/RBDQ	CECC 90104-157	Latch-Decoder-Driver, BCD to 7-segment
4512BF/RBDQ	CECC 90104-158	Data Selector, 8-Channel
4516BF/RBDQ	CECC 90104-161	Counter, Binary Up/Down
4517BF/RBDQ	CECC 90104-162	Shift Register, Dual 64-Bit Static
4518BF/RBDQ	CECC 90104-163	Counter, Dual BCD Up
4519BF/RBDQ	CECC 90104-164	Selector, 4-Bit AND/OR
4521BF/RBDQ	CECC 90104-176	Frequency Divider, 24-State
4526BF/RBDQ	CECC 90104-177	Counter, Binary Divide by N
4527BF/RBDQ	CECC 90104-168	Multiplier, BCD Rate
4528BF/RBDQ	CECC 90104-169	Multivibrator, Dual Monostable
4531BF/RBDQ	CECC 90104-197	Parity Tree, 12-Bit
4532BF/RBDQ	CECC 90104-178	Priority Encoder, 8-Bit
4536BF/RBDQ	CECC 90104-218	Timer, Programmable
4538BF/RBDQ	CECC 90104-179	Multivibrator, Dual Precision Monostable
4541BF/RBDQ	CECC 90104-180	Oscillator/Timer
4556BF/RBDQ	CECC 90104-181	Decoder, Dual Binary 1 of 4 (Inverting)
4584BF/RBDQ	CECC 90104-184	Schmitt Trigger, Hex
4585BF/RBDQ	CECC 90104-203	Magnitude Comparator, 4-Bit

6

## High Speed CMOS (HCMOS) Logic

Table 20. HCMOS Logic

Digital Logic Circuits in Dual-In-Line (DIL) Package

Device	Specification	Description
54HC00/YBDGAQ	CECC 90109-601	NAND Gate, Quad 2-Input
54HC02/YBDGAQ	CECC 90109-617	NOR Gate, Quad 2-Input
54HC03/YBDGAQ	CECC 90109-654	NAND Gate, Quad 2-Input OC
54HC04/YBDGAQ	CECC 90109-633	Inverter, Hex
54HC08/YBDGAQ	CECC 90109-605	AND Gate, Quad 2-Input
54HC10/YBDGAQ	CECC 90109-602	NAND Gate, Triple 3-Input
54HC11/YBDGAQ	CECC 90109-622	AND Gate, Triple 3-Input
54HC14/YBDGAQ	CECC 90109-640	Schmitt Trigger, Hex
54HC20/YBDGAQ	CECC 90109-603	NAND Gate, Dual 4-Input
54HC32/YBDGAQ	CECC 90109-619	OR Gate, Quad 2-Input
54HC42/YBDGAQ	CECC 90109-672	Decoder, 1 of 10
54HC74/YBDGAQ	CECC 90109-606	Flip-Flop, Dual D type
54HC85/YBDGAQ	CECC 90109-607	Magnitude Comparator, 4-Bit
54HC86/YBDGAQ	CECC 90109-620	Exclusive OR Gate, Quad
54HC107/YBDGAQ	CECC 90109-637	Flip-Flop, Dual J-K with Reset
54HC109/YBDGAQ	CECC 90109-627	Flip-Flop, Dual J-K with Preset. Pos. Trigger
54HC132/YBDGAQ	CECC 90109-623	Schmitt Trigger, Quad 2-Input
54HC138/YBDGAQ	CECC 90109-608	Decoder/Demultiplexer, 1 of 8
54HC139/YBDGAQ	CECC 90109-681	Decoder/Demultiplexer, Dual 1 of 4
54HC151/YBDGAQ	CECC 90109-641	Multiplexer, 8 Channel
54HC153/YBDGAQ	CECC 90109-642	Multiplexer, Dual 4-Input
54HC157/YBDGAQ	CECC 90109-643	Multiplexer/Data Selector, Quad 2-Input
54HC158/YBDGAQ	CECC 90109-644	Multiplexer/Data Selector, Quad 2-Input Inverter
54HC160/YBDGAQ	CECC 90109-630	Counter, Decade Async. Clear
54HC161/YBDGAQ	CECC 90109-631	Counter, 4-Bit Binary Sync. Clear
54HC162/YBDGAQ	CECC 90109-645	Counter, Decade Sync. Clear
54HC163/YBDGAQ	CECC 90109-646	Counter, 4-Bit Binary Sync. Clear
54HC164/YBDGAQ	CECC 90109-621	Shift Register, 8-Bit Serial to Parallel
54HC165/YBDGAQ	CECC 90109-682	Shift Register, 8-Bit Parallel Load
54HC173/YBDGAQ	CECC 90109-711	Register D type, 4-Bit, 3-state
54HC174/YBDGAQ	CECC 90109-609	Flip-Flop, Hex D type
54HC175/YBDGAQ	CECC 90109-624	Flip-Flop, Quad D type
54HC194/YBDGAQ	CECC 90109-615	Shift Register, 4-Bit Bidirectional, Universal
54HC195/YBDGAQ	CECC 90109-632	Shift Register 4-Bit, Universal
54HC240/YBDGAQ	CECC 90109-616	Buffer/Line Driver/Line Receiver Octal, 3-State Inverting Output
54HC242/YBDGAQ	CECC 90109-648	Bus Transceiver Quad 3-State Inverting Output
54HC244/YBDGAQ	CECC 90109-610	Buffer/Line Driver Quad 3-State
54HC245/YBDGAP	CECC 90109-611	Bus Transceiver Octal 3-State
54HC251/YBDGAQ	CECC 90109-683	Multiplexer 8-input, 3-State

6

**Table 20. HCMOS Logic (continued)****Digital Logic Circuits in Dual-In-Line (DIL) Package**

Device	Specification	Description
54HC253/YBDGAQ	CECC 90109-724	Multiplexer Dual 4-Input
54HC257/YBDGAQ	CECC 90109-628	Data Selector/Multiplexer Quad 2-Input, 3-State
54HC280/YBDGAQ	CECC 90109-612	Parity Generator 9-Bit Odd/Even
54HC373/YBDGAQ	CECC 90109-626	Latch (Transparent) Octal 3-State
54HC374/YBDGAQ	CECC 90109-613	Flip-Flop Octal D type 3-State
54HC390/YBDGAQ	CECC 90109-730	Ripple Counter Dual 4-Stage
54HC534/YBDGAQ	CECC 90109-614	Flip-Flop Octal D type 3-state, Inverting Output
54HC4002/YBDGAQ	CECC 90109-662	NOR Gate Dual 4-input
54HC4020/YBDGAQ	CECC 90109-629	Counter 14-Bit Binary
54HC4024/YBDGAQ	CECC 90109-655	Ripple Counter 7-Stage Binary
54HC4040/YBDGAQ	CECC 90109-656	Counter 12-Bit Binary
54HC4075/YBDGAQ	CECC 90109-663	OR Gate Triple 3-Input
54HCU04/YBDGAQ	CECC 90109-736	Inverter Hex Unbuffered

## Advanced Schottky TTL (FAST) Logic

Table 21. FAST Logic

Digital Logic Circuits in Dual-In-Line (DIL) Package

Device	Specification	Description
54F00/YBDGAQ	CECC 90107-001	NAND Gate, Quad 2-Input
54F02/YBDGAQ	CECC 90107-005	NOR Gate, Quad 2-Input
54F04/YBDGAQ	CECC 90107-003	Inverter, Hex
54F08/YBDGAQ	CECC 90107-006	AND Gate, Quad 2-Input
54F10/YBDGAQ	CECC 90107-004	NAND Gate, Triple 3-Input
54F11/YBDGAQ	CECC 90107-007	AND Gate, Triple 3-Input
54F20/YBDGAQ	CECC 90107-002	NAND Gate, Dual 4-Input
54F32/YBDGAQ	CECC 90107-008	OR Gate, Quad 2-Input
54F64/YBDGAQ	CECC 90107-009	AOI Gate, 4-2-3-2-Input
54F74/YBDGAQ	CECC 90107-010	Flip-Flop, Dual D type
54F109/YBDGAQ	CECC 90107-012	Flip-Flop, Dual J-K w/Preset Pos. Trigger
54F138/YBDGAQ	CECC 90107-013	Decoder/Demultiplexer, 1 of 8
54F139/YBDGAQ	CECC 90107-014	Decoder/Demultiplexer, Dual 1 of 4
54F153/YBDGAQ	CECC 90107-016	Multiplexer, Dual 4-Input
54F157A/YBDGAQ	CECC 90107-017	Multiplexer, Quad 2-Input
54F161A/YBDGAQ	CECC 90107-020	Counter, 4-Bit Binary Async. Reset
54F163A/YBDGAQ	CECC 90107-022	Counter, 4-Bit Binary Sync. Reset
54F174/YBDGAQ	CECC 90107-024	Flip-Flop, Hex D type
54F175/YBDGAQ	CECC 90107-025	Flip-Flop, Quad D type
54F240/YBDGAQ	CECC 90107-030	Buffer/Line Driver, Octal 3-State Inverting
54F241/YBDGAQ	CECC 90107-031	Buffer/Line Driver, Octal 3-State
54F244/YBDGAQ	CECC 90107-032	Buffer/Line Driver, Quad 3-State
54F245/YBDGAQ	CECC 90107-034	Bus Transceiver, Octal
54F373/YBDGAQ	CECC 90107-040	Latch (Transparent), Octal 3-State
54F374/YBDGAQ	CECC 90107-041	Flip-Flop, Octal D type 3-State

## Low Power Schottky (LS) TTL

**Table 22. Low Power Schottky (LS) TTL**  
**Digital Logic Circuits in Dual-In-Line (DIL) Package**

Device	Specification	Description
54LS00/RBDQ	CECC 90103-001	NAND Gate, Quad 2-Input
54LS00/YBDGAQ2	CECC 90103-183	NAND Gate, Quad 2-Input
54LS02/RBDQ	CECC 90103-003	NOR Gate, Quad 2-Input
54LS02/YBDGAQ2	CECC 90103-188	NOR Gate, Quad 2-Input
54LS03/YBDGAQ2	CECC 90103-186	NAND Gate, Quad 2-Input OC
54LS04/RBDQ	CECC 90103-005	Inverter, Hex
54LS04/YBDGAQ2	CECC 90103-183	Inverter, Hex
54LS05/YBDGAQ2	CECC 90103-186	Inverter, Hex OC
54LS08/RBDQ	CECC 90103-007	AND Gate, Quad 2-Input
54LS08/YBDGAQ2	CECC 90103-226	AND Gate, Quad 2-Input
54LS09/YBDGAQ2	CECC 90103-226	AND Gate, Quad 2-Input
54LS10/RBDQ	CECC 90103-009	NAND Gate, Triple 3-Input
54LS10/YBDGAQ2	CECC 90103-183	NAND Gate, Triple 3-Input
54LS11/RBDQ	CECC 90103-010	AND Gate, Triple 3-Input
54LS11/YBDGAQ2	CECC 90103-226	AND Gate, Triple 3-Input
54LS14/RBDQ	CECC 90103-013	Schmitt Trigger, Hex
54LS11/YBDGAQ2	CECC 90103-225	Schmitt Trigger, Hex
54LS20/RBDQ	CECC 90103-015	NAND Gate, Dual 4-Input
54LS20/YBDGAQ2	CECC 90103-183	NAND Gate, Dual 4-Input
54LS21/RBDQ	CECC 90103-016	AND Gate, Dual 4-Input
54LS21/YBDGAQ2	CECC 90103-226	AND Gate, Dual 4-Input
54LS22/YBDGAQ2	CECC 90103-186	NAND Gate, Dual 4-Input
54LS26/RBDQ	CECC 90103-018	NAND Gate, Quad 2-Input (High Voltage)
54LS26/YBDGAQ2	CECC 90103-190	NAND Gate, Quad 2-Input (High Voltage)
54LS27/RBDQ	CECC 90103-019	NOR Gate, Triple 3-Input
54LS28/RBDQ	CECC 90103-020	Buffer, Quad 2-Input NAND
54LS28/YBDGAQ2	CECC 90103-218	Buffer, Quad 2-Input NAND
54LS30/YBDGAQ2	CECC 90103-184	NAND Gate, 8-Input
54LS32/RBDQ	CECC 90103-022	OR Gate, Quad 2-Input
54LS32/YBDGAQ2	CECC 90103-208	OR Gate, Quad 2-Input
54LS37/RBDQ	CECC 90103-024	Buffer, Quad 2-Input NAND
54LS37/YBDGAQ2	CECC 90103-185	Buffer, Quad 2-Input NAND
54LS38/RBDQ	CECC 90103-025	Buffer, 4-input NAND
54LS42/RBDQ	CECC 90103-027	Decoder, 1 of 10
54LS51/RBDQ	CECC 90103-030	AOI Gate, Dual
54LS51/YBDGAQ2	CECC 90103-189	AOI Gate, Dual
54LS54/YBDGAQ2	CECC 90103-189	AOI Gate, 3-2-2-3-Input
54LS73A/RBDQ	CECC 90103-033	Flip-Flop, Dual J-K
54LS73A/YBDGAQ2	CECC 90103-283	Flip-Flop, Dual J-K

6

**Table 22. Low Power Schottky (LS) TTL (continued)**  
**Digital Logic Circuits in Dual-In-Line (DIL) Package**

Device	Specification	Description
54LS74A/RBDQ	CECC 90103-034	Flip-Flop, Dual D type
54LS74A/YBDGAQ2	CECC 90103-196	Flip-Flop, Dual D type
54LS75/YBDGAQ2	CECC 90103-268	Latch, 4-bit Bistable with Q/ $\bar{Q}$
54LS85/RBDQ	CECC 90103-039	Magnitude Comparator, 4-Bit
54LS85/YBDGAQ2	CECC 90103-199	Magnitude Comparator, 4-Bit
54LS86/RBDQ	CECC 90103-040	Exclusive OR Gate, Quad
54LS86/YBDGAQ2	CECC 90103-275	Exclusive OR Gate, Quad
54LS107A/YBDGAQ2	CECC 90103-283	Flip-Flop, Dual J-K Edge Triggered
54LS109A/YBDGAQ2	CECC 90103-200	Flip-Flop, Dual J-K with Preset. Pos. Trigger
54LS112A/RBDQ	CECC 90103-048	Flip-Flop, Dual J-K with Clear
54LS112A/YBDGAQ2	CECC 90103-228	Flip-Flop, Dual J-K with Clear
54LS122/YBDGAQ2	CECC 90103-237	Multivibrator, Retriggerable Monostable
54LS123/RBDQ	CECC 90103-051	Multivibrator, Retriggerable Monostable
54LS123/YBDGAQ2	CECC 90103-191	Multivibrator, Dual Retriggerable Monostable
54LS125A/RBDQ	CECC 90103-053	Buffer, Quad 3-State Low Enable
54LS125A/YBDGAQ2	CECC 90103-201	Buffer, Quad 3-State Low Enable
54LS132/RBDQ	CECC 90103-055	Schmitt Trigger, Quad 2-Input
54LS132/YBDGAQ2	CECC 90103-225	Schmitt Trigger, Quad 2-Input
54LS138/RBDQ	CECC 90103-057	Decoder/Demultiplexer, 1 of 8
54LS138/YBDGAQ2	CECC 90103-209	Decoder/Demultiplexer, 1 of 8
54LS139/RBDQ	CECC 90103-058	Decoder/Demultiplexer, Dual 1 of 4
54LS139/YBDGAQ2	CECC 90103-209	Decoder/Demultiplexer, Dual 1 of 4
54LS151/RBDQ	CECC 90103-062	Multiplexer, 8-Channel
54LS153/RBDQ	CECC 90103-063	Multiplexer, Dual 4-Input
54LS153/YBDGAQ2	CECC 90103-194	Multiplexer, Dual 4-Input
54LS155/RBDQ	CECC 90103-136	Decoder, Dual Binary 1 of 4
54LS155/YBDGAQ2	CECC 90103-197	Decoder, Dual Binary 1 of 4
54LS157/RBDQ	CECC 90103-065	Multiplexer/Data Selector, Quad 2-Input
54LS157/YBDGAQ2	CECC 90103-195	Multiplexer/Data Selector, Quad 2-Input
54LS161A/RBDQ	CECC 90103-068	Counter, 4-Bit Binary Async. Reset
54LS161A/YBDGAQ2	CECC 90103-210	Counter, 4-Bit Binary Async. Reset
54LS163A/RBDQ	CECC 90103-070	Counter, 4-Bit Binary Sync. Reset
54LS163A/YBDGAQ2	CECC 90103-255	Counter, 4-Bit Binary Sync. Reset
54LS164/RBDQ	CECC 90103-071	Shift Register, 8-Bit Serial to Parallel
54LS164/YBDGAQ2	CECC 90103-207	Shift Register, 8-Bit Serial to Parallel
54LS170/RBDQ	CECC 90103-075	Register File, 4 by 4 OC
54LS170/YBDGAQ2	CECC 90103-261	Register File, 4 by 4 OC
54LS174/RBDQ	CECC 90103-077	Flip-Flop, Hex D Type
54LS174/YBDGAQ2	CECC 90103-202	Flip-Flop, Hex D Type
54LS175/RBDQ	CECC 90103-138	Flip-Flop, Quad D Type
54LS175/YBDGAQ2	CECC 90103-205	Flip-Flop, Quad D Type

6



**Table 22. Low Power Schottky (LS) TTL (continued)**  
**Digital Logic Circuits in Dual-In-Line (DIL) Package**

Device	Specification	Description
54LS191/RBDQ	CECC 90103-139	Counter, Decade Up/Down with Clear
54LS191/YBDGAQ2	CECC 90103-266	Counter, Decade Up/Down with Clear
54LS193/RBDQ	CECC 90103-083	Counter, Binary Up/Down with Clear
54LS193/YBDGAQ2	CECC 90103-214	Counter, Binary Up/Down with Clear
54LS221/YBDGAQ2	CECC 90103-220	One Shot, Dual
54LS240/RBDQ	CECC 90103-087	Buffer/Line Driver, Octal 3-State Inverting
54LS240/YBDGAQ2	CECC 90103-217	Buffer/Line Driver, Octal 3-State Inverting
54LS241/RBDQ	CECC 90103-088	Buffer/Line Driver, Octal 3-State
54LS241/YBDGAQ2	CECC 90103-276	Buffer/Line Driver, Octal 3-State
54LS244/RBDQ	CECC 90103-091	Buffer/Line Driver, Quad 3-State
54LS244/YBDGAQ2	CECC 90103-216	Buffer/Line Driver, Quad 3-State
54LS245/RBDQ	CECC 90103-092	Bus Transceiver, Octal
54LS245/YBDGAQ2	CECC 90103-250	Bus Transceiver, Octal
54LS253/RBDQ	CECC 90103-097	Multiplexer, Dual 4-Input
54LS253/YBDGAQ2	CECC 90103-212	Multiplexer, Dual 4-Input
54LS257A/RBDQ	CECC 90103-098	Multiplexer, Quad 2-Input Non-Inverting
54LS257A/YBDGAQ2	CECC 90103-213	Multiplexer, Quad 2-Input Non-Inverting
54LS259/RBDQ	CECC 90103-100	Latch, 8-Bit Addressable
54LS259/YBDGAQ2	CECC 90103-203	Latch, 8-Bit Addressable
54LS273/RBDQ	CECC 90103-102	Flip-Flop, Octal D Type with Clock/Reset
54LS273/YBDGAQ2	CECC 90103-249	Flip-Flop, Octal D Type with Clock/Reset
54LS279/RBDQ	CECC 90103-104	Latch, Quad Set/Reset
54LS279/YBDGAQ2	CECC 90103-238	Latch, Quad Set/Reset
54LS283/YBDGAQ2	CECC 90103-204	Full Adder, 4-Bit (Rotated LS83A)
54LS298/YBDGAQ2	CECC 90103-239	Multiplexer, Quad 2-Input with Output Register
54LS365A/YBDGAQ2	CECC 90103-272	Hex Buffer, Common Enable 3-State
54LS366A/YBDGAQ2	CECC 90103-262	Inverter, Hex 3-State, Common Enable
54LS367A/RBDQ	CECC 90103-121	Buffer, Hex 3-State, 4-Bit and 2-Bit
54LS367A/YBDGAQ2	CECC 90103-235	Buffer, Hex 3-State, 4-Bit and 2-Bit
54LS368A/YBDGAQ2	CECC 90103-240	Inverter, Hex 3-State, 4-Bit and 2-Bit
54LS373/RBDQ	CECC 90103-122	Latch, Octal, Transparent 3-State
54LS373/YBDGAQ2	CECC 90103-223	Latch, Octal, Transparent 3-State
54LS374/RBDQ	CECC 90103-123	Flip-Flop, Octal D Type
54LS374/YBDGAQ2	CECC 90103-224	Flip-Flop, Octal D Type
54LS390/RBDQ	CECC 90103-128	Counter, Dual Decade
54LS390/YBDGAQ2	CECC 90103-263	Counter, Dual Decade
54LS393/RBDQ	CECC 90103-129	Counter, Dual 4-Bit Binary
54LS393/YBDGAQ2	CECC 90103-264	Counter, Dual 4-Bit Binary
54LS670/RBDQ	CECC 90103-174	Register File, 4 x 4 3-State
54LS670/YBDGAQ2	CECC 90103-192	Register File, 4 x 4 3-State

6

# Advanced CMOS Technology

**Table 23. AC Series**

**Digital Logic Circuits in Dual-In-Line (DIL) Package**

Device	Specification	Description
54AC00/YBDGAQ	UTE C 96-223-FC004	NAND Gate, Quad 2-Input
54AC02/YBDGAQ	UTE C 96-223-FC007	NOR Gate, Quad 2-Input
54AC04/YBDGAQ	UTE C 96-223-FC011	Inverter, Hex
54AC08/YBDGAQ	UTE C 96-223-FC009	AND Gate, Quad 2-Input
54AC10/YBDGAQ	UTE C 96-223-FC006	NAND Gate, Triple 3-Input
54AC11/YBDGAQ	UTE C 96-223-FC008	AND Gate, Triple 3-Input
54AC14/YBDGAQ	UTE C 96-223-FC012	Schmitt Trigger, Hex
54AC32/YBDGAQ	UTE C 96-223-FC005	OR Gate, Quad 2-Input
54AC74/YBDGAQ	UTE C 96-223-FC014	Flip-Flop, Dual D type
54AC109/YBDGAQ	UTE C 96-223-FC015	Flip-Flop, Dual J-K with Preset Pos. Trigger
54AC138/YBDGAQ	UTE C 96-223-FC001	Decoder/Demultiplexer, 1 of 8
54AC158/YBDGAQ	UTE C 96-223-FC013	Multiplexer/Data Selector, Quad 2-Input inverter
54AC163/YBDGAQ	UTE C 96-223-FC016	Counter, 4-Bit Binary Sync. Clear
54AC174/YBDGAQ	UTE C 96-223-FC010	Flip-Flop, Hex D type
54AC240/YBDGAQ	UTE C 96-223-FC036	Flip-Flop, Hex D type
54AC244/YBDGAQ	UTE C 96-223-FC037	Buffer/Line Driver, Quad 3-State
54AC245/YBDGAQ	UTE C 96-223-FC038	Bus Transceiver, Octal
54AC273/YBDGAQ	UTE C 96-223-FC034	Flip-Flop, Octal D type with Clock/Reset
54AC299/YBDGAQ	UTE C 96-223-FC003	Shift/Store Register, 8-Bit with TTL inputs
54AC373/YBDGAQ	UTE C 96-223-FC039	Latch, Octal, Transparent 3-State
54AC374/YBDGAQ	UTE C 96-223-FC040	Flip-Flop, Octal D type

**Table 24. ACT Series**

**Digital Logic Circuits in Dual-In-Line (DIL) Package**

Device	Specification	Description
54ACT00/YBDGAQ	UTE C 96-223-FC018	NAND Gate, Quad 2-Input
54ACT02/YBDGAQ	UTE C 96-223-FC017	NOR Gate, Quad 2-Input
54ACT04/YBDGAQ	UTE C 96-223-FC041	Inverter, Hex
54ACT08/YBDGAQ	UTE C 96-223-FC020	AND Gate, Quad 2-Input
54ACT11/YBDGAQ	UTE C 96-223-FC019	AND Gate, Triple 3-Input
54ACT14/YBDGAQ	UTE C 96-223-FC025	Schmitt Trigger, Hex
54ACT32/YBDGAQ	UTE C 96-223-FC021	OR Gate, Quad 2-Input
54ACT74/YBDGAQ	UTE C 96-223-FC026	Flip-Flop, Dual D type
54ACT109/YBDGAQ	UTE C 96-223-FC043	Flip-Flop, Dual J-K with Preset Pos. Trigger
54ACT138/YBDGAQ	UTE C 96-223-FC029	Decoder/Demultiplexer, 1 of 8
54ACT139/YBDGAQ	UTE C 96-223-FC030	Decoder/Demultiplexer, Dual 1 of 4
54ACT151/YBDGAQ	UTE C 96-223-FC024	Multiplexer, 8-Channel
54ACT157/YBDGAQ	UTE C 96-223-FC022	Multiplexer/Data Selector, Quad 2-Input
54ACT161/YBDGAQ	UTE C 96-223-FC027	Counter, 4-Bit Binary Async. Clear

6

**Table 24. ACT Series (continued)**

**Digital Logic Circuits in Dual-In-Line (DIL) Package**

Device	Specification	Description
54ACT163/YBDGAQ	UTE C 96-223-FC028	Counter, 4-Bit Binary Sync. Clear
54ACT244/YBDGAQ	UTE C 96-223-FC033	Buffer/Line Driver, Quad 3-state
54ACT245/YBDGAQ	UTE C 96-223-FC031	Bus Transceiver, Octal
54ACT257/YBDGAQ	UTE C 96-223-FC023	Data Selector/Multiplexer, Quad 2-Input 3-State
54ACT373/YBDGAQ	UTE C 96-223-FC002	Latch, Octal, Transparent 3-State
54ACT374/YBDGAQ	UTE C 96-223-FC032	Flip-Flop, Octal D type
54ACT564/YBDGAQ	UTE C 96-223-FC044	Latch, Octal D type 3-State

## Analog Functions

**Table 25. Analog Functions**

**CECC Qualified**

Device	Specification	Description
26LS31C/YBDGAQ	CECC 90301-002	RS-422 Line Driver, Quad 3-State
26LS32C/YBDGAQ	CECC 90301-003	RS-422 Line Receiver, Quad 3-State
071M/YBDGAQ	CECC 90202-035	Operational Amplifier, JFET
072M/YBDGAQ	CECC 90202-035	Operational Amplifier, JFET
074M/YBDGAQ	CECC 90202-035	Operational Amplifier, JFET
081M/YBDGAQ	CECC 90202-038	Operational Amplifier, JFET
082M/YBDGAQ	CECC 90202-038	Operational Amplifier, JFET
084M/YBDGAQ	CECC 90202-038	Operational Amplifier, JFET
101A/YBCMAQ	CECC 90202-018	Operational Amplifier, Adjustable General Purpose
101A/YBDGAQ	CECC 90202-018	Operational Amplifier, Adjustable General Purpose
108/YBCMAQ	CECC 90202-015	Operational Amplifier, Precision
108/YBDGAQ	CECC 90202-015	Operational Amplifier, Precision
108A/YBCMAQ	CECC 90202-014	Operational Amplifier, Precision
108A/YBDGAQ	CECC 90202-014	Operational Amplifier, Precision
111/YBCMAQ	CECC 90302-002	Voltage Comparator, High Performance
111/YBDGAQ	CECC 90302-002	Voltage Comparator, High Performance
117/YBCMAQ	CECC 90201-005	Voltage Regulator, Positive Adjustable 3-Terminal
117/YBKMAQ	CECC 90201-005	Voltage Regulator, Positive Adjustable 3-Terminal
124/YBDGAQ	CECC 90202-029	Operational Amplifier, Quad, Low Power
137/YBCMAQ	CECC 90201-007	Voltage Regulator, Negative Adjustable 3-Terminal
137/YBKMAQ	CECC 90201-007	Voltage Regulator, Negative Adjustable 3-Terminal
139/YBDGAQ	CECC 90302-008	Comparator, Quad, Single Supply
139A/YBDGAQ	CECC 90302-010	Comparator, Quad, Single Supply
148/YBDGAQ	CECC 90202-003	Operational Amplifier, Quad, Low Power
155/YBCMAQ	CECC 90202-005	Operational Amplifier, JFET
155A/YBCMAQ	CECC 90202-006	Operational Amplifier, JFET
156/YBCMAQ	CECC 90202-007	Operational Amplifier, JFET

6

**Table 25. Analog Functions (continued)**

**CECC Qualified**

Device	Specification	Description
156A/YBCMAQ	CECC 90202-008	Operational Amplifier, JFET
157/YBCMAQ	CECC 90202-009	Operational Amplifier, JFET
158/YBCMAQ	CECC 90202-031	Operational Amplifier, Dual Low Power
158/YBDGAQ	CECC 90202-031	Operational Amplifier, Dual Low Power
193/YBCMAQ	CECC 90303-004	Voltage Comparator, High Performance
193A/YBCMAQ	CECC 90302-006	Voltage Comparator, High Performance
723/YBCMAQ	CECC 90201-002	Voltage Regulator, Positive or Negative Adjustable
723/YBDGAQ	CECC 90201-002	Voltage Regulator, Positive or Negative Adjustable
741/YBCMAQ	CECC 90202-022	Operational Amplifier, General Purpose
741/YBDGAQ	CECC 90202-022	Operational Amplifier, General Purpose
747/YBCMAQ	CECC 90202-043	Operational Amplifier, Dual 741 Type
747/YBDGAQ	CECC 90202-043	Operational Amplifier, Dual 741 Type
776/YBCMAQ	CECC 90202-025	Operational Amplifier, Programmable
776/YBDGAQ	CECC 90202-025	Operational Amplifier, Programmable
1558/YBCMAQ	CECC 90202-023	Operational Amplifier, Dual Low Noise
1558/YBDGAQ	CECC 90202-023	Operational Amplifier, Dual Low Noise
7805C/YBKMAQ	CECC 90201-011	Voltage Regulator, Positive 5 Volts, 3-Terminal
7812C/YBKMAQ	CECC 90201-013	Voltage Regulator, Positive 12 Volts, 3-Terminal
7815C/YBKMAQ	CECC 90201-015	Voltage Regulator, Positive 15 Volts, 3-Terminal
7824C/YBKMAQ	CECC 90201-017	Voltage Regulator, Positive 24 Volts, 3-Terminal

**Table 26. Analog Functions**

**CECC Processed**

Device	Description
8T26AC/NBDGAP	Bus Transceiver, Quad 3-State
8T97/NBDGAP	Buffer, Hex 3-State
8T98/NBDGAP	Inverter, Hex 3-State
123/NBKMAP	Voltage Regulator, Positive 5 Volt 3-Amp
1513/NBDGAP	Darlington Transistor Array, High Current
1514/NBDGAP	Differential Comparator, Dual
1525A/NBDGAP	Controller, Pulse Width Modulation
1526/NBDGAP	Controller, Pulse Width Modulation
1536/NBCMAP	Operational Amplifier, High Voltage
1555/NBCMAP	Timing Circuit
1555/NBDGAP	Timing Circuit
1588/NBDGAP	Operational Amplifier, Dual Low Noise
1589/NBDGAP	Line Receiver, Quad MDTL
1590/NBCMAP	Amplifier, Wideband with AGC
1596/NBDGAP	Modulator/Demodulator, Balanced
1596/NBPCCP	Modulator/Demodulator, Balanced
1741S/NBCMAP	Operational Amplifier, General Purpose
1748/NBCMAP	Operational Amplifier, General Purpose

**6**

**Table 26. Analog Functions (continued)****CECC Processed**

Device	Description
1748/NBDGAP	Operational Amplifier, General Purpose
3486/NBDGAP	RS422/423, Quad 3-State Output, Input Hysteresis
3523/NBDGAP	Overvoltage Sensing Circuit
4741/NBDGAP	Operational Amplifier, Quad 1741
35074/NBDGAP	Operational Amplifier, Quad High Performance Single Supply

**Table 27. Analog Functions****ESA/SCCG (Space) Qualified**

Device	Description
LM11H	SCC 9101-022
LM101AH	SCC 9101-001
LM108AH	SCC 9101-005
LM117AH	SCC 9102-005
LM117K	SCC 9102-005
LM124AJ	SCC 9101-011
LM124J	SCC 9101-011
LM137H	SCC 9101-007
LM137K	SCC 9101-007
LM139AJ	SCC 9103-004
LM139J	SCC 9103-004

**6**

# Discretes

## Part Number Ordering Information

**2N2222A X / X X X**



Device Title	_____			
Lead Finish	A: Solder dip	B: Acid tin plate	C: Gold	X: Any
Assessment Level as CECC 50000	_____			
Test	B: Sequence	B of CECC 50000		
Qualification Flag	Q: Qualified	P: Processed		

example of Discrete device title – **2N2222AB/FBQ**

**Note:** If you are unable to find your requirements for qualified Discrete devices from the following pages, please contact your local Motorola Sales Office.

## Marking Information

All or part of the following information is marked depending on package size and available space, the CECC logo is only used if the part is fully qualified.

	<b>2N2222A</b>	<b>B</b>		<b>9201</b>
Motorola Logo	Device Type	Sequence	CECC Logo	Date Code

## Transistors

**Table 28. Small Signal Metal Can Transistor  
CECC Qualified**

Device	Specification
2N1613B/FBQ	CECC 50002-104
2N1711B/FBQ	CECC 50002-104
2N1893B/FBQ	CECC 50002-104
2N2218AB/FBQ	CECC 50002-100
2N2219AA/FAQ	CECC 50002-100
2N2219AA/FBQ	CECC 50002-100
2N2219AB/FBQ	CECC 50002-100
2N2222AA/FBQ	CECC 50002-101
2N2222AB/FAQ	CECC 50002-101
2N2222AB/FBQ	CECC 50002-101
2N2369AB/FBQ	CECC 50004-022
2N2905AA/FBQ	CECC 50002-102
2N2905AB/FBQ	CECC 50002-102
2N2907AA/FBQ	CECC 50002-103
2N2907AB/FAQ	CECC 50002-103
2N2907AB/FBQ	CECC 50002-103
2N3019B/FBQ	CECC 50002-175
2N3439B/FBQ	CECC 50002-189
2N3440B/FBQ	CECC 50002-189
2N5415B/FBQ	CECC 50003-029
2N5416B/FBQ	CECC 50003-029

**6**

**Table 29. Small Signal Metal Can Transistor  
ESA/SCCG (Space) Qualified**

Device	Specification
2N2222A	SCC 5201-002
2N2907A	SCC 5202-001
2N2219A	SCC 5201-003
2N2905A	SCC 5202-002
2N3439/2N3440	SCC 5203-011
2N3501/2N3499	SCC 5203-013
2N3637/2N3636	SCC 5208-033

**Table 30. Small Signal Metal Can Transistor  
CECC Processed**

Device	Specification
BCY59B/NBP BCY79B/NBP BC107B/NBP	2N2102B/NBP
	2N2919B/NBP
	2N2920B/NBP
	2N3501B/NBP
	2N3634B/NBP
	2N3637B/NBP
	2N3700B/NBP
	2N3964B/NBP
	2N4036B/NBP
	2N4091B/NBP
BSS51 B/NBP	2N4092B/NBP
	2N4236B/NBP
BSS71 B/NBP	2N4261X/NBP
BSS73B/NBP	2N4860A/NBP
BSS74B/NBP	2N4860B/NBP
BSS76B/NBP	2N5322B/NBP
BSX52BB/NBP	2N5680B/NBP
	2N5682B/NBP
	2N930B/NBP

**Table 31. Power Transistor  
CECC Processed**

Device	Specification
BDX66AA/NBP	2N3054A/NBP
BDX67AA/NBP	2N3055A/NBP
BD243BA/NBP	2N3055AA/NBP
BD244BA/NBP	2N3441A/NBP
	2N3442A/NBP
BUS48A/NBP	2N3585A/NBP
BUS50A/NBP	2N3715A/NBP
BUS98AA/NBP	2N3716A/NBP
BUV11A/NBP	2N3738A/NBP
BUX10A/NBP	2N3740A/NBP
BUX20A/NBP	2N3741A/NBP
	2N3767A/NBP
BUX48A/NBP	2N3791A/NBP
	2N4912A/NBP
MJ10005A/NBP	2N5884A/NBP
MJ10016A/NBP	2N5886A/NBP
MJ11012A/NBP	2N6052A/NBP

**6**



**Table 31. Power Transistor (continued)**  
**CECC Processed**

Device	Specification
MJ15001A/NBP	2N6059A/NBP
MJ15002A/NBP	2N6233A/NBP
MJ15012A/NBP	2N6284A/NBP
MJ15015A/NBP	2N6287A/NBP
MJ15022A/FBP	2N6317A/NBP
MJ15023A/FBP	2N6609A/NBP
MJ16012A/NBP	
MJ16018A/NBP	
MJ2501A/NBP	
MJ2955A/NBP	
MJ3001A/NBP	
MJ4502A/NBP	
MJ4647A/NBP	

**Table 32. TMOS Transistors**  
**CECC Processed**

IRF130A/NBP
IRF140A/NBP
IRF150A/NBP
IRF250A/NBP
IRF330A/NBP
IRF350A/NBP
IRF450A/NBP

**Table 33. MOSFET Transistors**  
**CECC Processed**

2N4392B/NBP
2N4393B/NBP
2N4857B/NBP

**6**

**Table 34. JFET TMOS Transistors**  
**CECC Processed**

2N3821X/NBP
2N4416AX/NBP
2N4416X/NBP

**Table 35. Dual Transistors**  
**CECC Processed**

MD2369AB/NBP
MD5000AX/NBP
MD6003B/NBP
MD918AB/NBP
2N3810B/NBP
2N3811B/NBP

**Table 36. Quad Transistors  
CECC Processed**

MHQ2222X/NBP
MHQ2369X/NBP
MHQ2907X/NBP
MHQ3467X/NBP
MHQ3735X/NBP
MHQ6002X/NBP

**Table 37. RF Transistors  
CECC Processed**

BFY90X/NBP
MRF904X/NBP
MRF914X/NBP
2N3553X/NBP
2N5109B/NBP
2N5583X/NBP

## Diodes/Rectifiers

**Table 38. Zener Diodes  
CECC Processed**

Device	Specification
BZX55C10A/NBP	BZX85C16A/NBP
BZX55C11A/NBP	BZX85C18A/NBP
BZX55C12A/NBP	BZX85C20A/NBP
BZX55C13A/NBP	BZX85C22A/NBP
BZX55C15A/NBP	BZX85C24A/NBP
BZX55C16A/NBP	BZX85C27A/NBP
BZX55C18A/NBP	BZX85C3V3A/NBP
BZX55C2V4A/NBP	BZX85C3V6A/NBP
BZX55C2V7A/NBP	BZX85C3V9A/NBP
BZX55C20A/NBP	BZX85C30A/NBP
BZX55C22A/NBP	BZX85C33A/NBP
BZX55C24A/NBP	BZX85C36A/NBP
BZX55C3V0A/NBP	BZX85C39A/NBP
BZX55C3V3A/NBP	BZX85C4V7A/NBP
BZX55C3V9A/NBP	BZX85C5V1A/NBP
BZX55C30A/NBP	BZX85C5V6A/NBP
BZX55C33A/NBP	BZX85C56A/NBP
BZX55C36A/NBP	BZX85C6V2A/NBP
BZX55C4V7A/NBP	BZX85C6V8A/NBP
BZX55C5V1A/NBP	BZX85C62A/NBP
BZX55C5V6A/NBP	BZX85C7V5A/NBP
BZX55C6V2A/NBP	BZX85C8V2A/NBP
BZX55C6V8A/NBP	BZX85C82A/NBP
BZX55C62A/NBP	BZX85C9V1A/NBP

6

**Table 38. Zener Diodes (continued)**  
**CECC Processed**

Device	Specification
BZX55C7V5A/NBP	
BZX55C8V2A/NBP	
BZX55C9V1A/NBP	1N821AX/NBP
BZX85C10A/NBP	1N823AX/NBP
BZX85C100A/NBP	1N825AA/NBP
BZX85C11A/NBP	1N825AX/NBP
BZX85C12A/NBP	1N827AX/NBP
BZX85C13A/NBP	1N829AX/NBP
BZX85C15A/NBP	

**Table 39. Rectifiers**  
**CECC Processed**

BYS35-45X/NBP	1N4749AA/NBP
BYS35-50/NBP	1N4750AA/NBP
BYS60-45X/NBP	1N4751AA/NBP
BYS75-45X/NBP	1N4752AA/NBP
BYS75-50X/NBP	1N4753AA/NBP
BYW77-150X/NBP	1N4754AA/NBP
BYW77-200X/NBP	1N4755AA/NBP
	1N4756AA/NBP
	1N4757AA/NBP
	1N4758AA/NBP
	1N4759AA/NBP
	1N4760AA/NBP
	1N4761AA/NBP
	1N4762AA/NBP
	1N4763AA/NBP
	1N4764AA/NBP
	1N4935X/NBP
	1N4936X/NBP
	1N4937X/NBP
	1N5314X/NBP
	1N5359BA/NBP
1N4734AA/NBP	1N5817X/NBP
1N4746AA/NBP	1N5818X/NBP
1N4747AA/NBP	1N5819X/NBP
1N4748AA/NBP	1N5822B/NBP
	1N5823X/NBP
	1N5825B/NBP
	1N6096X/NBP

**Table 40. Tuning Diodes**  
**CECC Processed**

MV1404X/NBP
-------------

6

# Product Literature and Technical Training

---

## In Brief . . .

With the pace of new semiconductor product introductions, the task of providing an effective and up-to-date perspective of available components is beyond the means of any single document. Hence, a comprehensive Motorola Literature System has been put in place to keep semiconductor users totally informed of all aspects of the Motorola product lines — from new product introductions, to applications, to major changes in directions.

The Motorola technical literature library and associated services consist of the following:

- An extensive library of Data Books, each containing a complete selection of data sheets associated with a particular product line.
- A series of User's Manuals and Design Manuals dealing with the application of highly complex products.
- A wide range of Application Notes and Article Reprints detailing the utilization of new and significant products.
- Instructor-led Training for: Digital Signal Processing (DSP) Family; M68000 Family; Embedded Controllers (EC); MC68360 QUIC; PowerPC; Microcontroller (MCU); RISC Family; plus the MC68302, MC68332, MC68340 and the MC68HC16.
- Audio Cassette Course programs covering the M68000 Family, the DSP56000/1, and the MC88100/200 RISC.

These products and services are described on the following pages. However, because of different conditions and standards, some of these may not be available outside the USA.

	<b>Page</b>
Technical Data Services .....	7.1-1
Motorola Semiconductor Master Selection Guide . . .	7.1-1
Semiconductor Data Update Magazine .....	7.1-1
Mfax — Touch-Tone Fax .....	7.1-1
Design-NET — Motorola Data On-Line .....	7.1-1
Motorola Data and Application Literature .....	7.1-2
Discrete Literature .....	7.1-2
IC Literature .....	7.1-2
Motorola Application Literature .....	7.1-5
Technical Training 1994 .....	7.1-6
Technical Training Centers .....	7.1-8
Audio Cassette Courses .....	7.1-9
Video Training .....	7.1-10

**7**

# Technical Data Services

## Motorola Semiconductor Master Selection Guide

*For the identification and preliminary selection of components for circuit and system designs*

For the design engineer, the Motorola Master Selection Guide is perhaps the most important single document for the identification and preliminary selection of components for circuit and system designs. Within its pages is a complete listing and description of Motorola semiconductor devices currently in general use, and those recommended for new designs. It serves two purposes:

1. It lists all standard products in the vast Motorola semiconductor inventory for rapid identification.
2. It divides this total product offering into a variety of major product categories, with sufficient technical information to permit an intelligent first-order evaluation as to the most suitable devices for a specific application.

## Semiconductor Data Update Magazine

*Innovative new developments from Motorola's Semiconductor Products Sector*

This highly informative periodical is available to all semiconductor users on a free subscription basis. The magazine provides information on new semiconductor products and developments and provides a quick-scan insight into new-product offerings. Concise, informative articles discuss significant new product capabilities as well as newly introduced services and literature. In short, it represents an overview of the latest and most important events at Motorola that influence the efficient implementation and most cost-effective use of semiconductor devices.

We recently introduced an International edition of the periodical, which is now available throughout the European community. In addition to the informative news you've come to expect about Motorola's leading-edge products, this new broader coverage will enable us to highlight manufacturing, awards, special events, and trade shows from an international perspective.

For your free Update Magazine subscription in the USA, please contact the Literature Distribution Center. The subscription service may not be available outside the USA.

## Mfax — Touch-Tone Fax

**Mfax** offers access to over 30,000 Motorola documents for faxing to customers worldwide. With menus and voice instruction, customers can request the documents needed using their own touch-tone telephones from any location 7 days a week and 24 hours a day. The telephone number is (602) 897-5725.

A number of features are offered within the **Mfax** system, including HOT DOCS (4-digit code identifiers for currently

referenced promotional or advertising material), Literature Order Forms, and Technical Training Information.

Motorola has a full time staff dedicated to supporting the Design-NET service as well as the **Mfax** Touch-Tone Faxing service.

## Design-NET — Motorola Data On-Line

*Information about Motorola Semiconductors is now available from an on-line service(\*) via your desk-top computer. Also, this information is continually being updated on a regular basis.*

The resource is an engineering/purchasing tool which speeds device selection, gives you access to applications data, and many other product and service related items. The system is available 24 hours a day, seven days a week with local access phone numbers in thousands of locations throughout the U.S. and many other countries.

The device selection feature contains up to the minute data on over 10,000 devices recommended for new applications with over 32,000 cross-references to these devices. The devices are organized into over 110 categories for easy access. Once a device has been located, its current OEM price and ordering data are available or a data sheet can be faxed from the system.

Some of the features currently available on Design-NET include:

- "Specs-In-Secs" device data
- Press releases
- Literature catalog
- Training information and schedules
- Technical Forum
- Motorola news
- Application Note abstracts
- Trade show schedules
- Product Bulletins and notices
- E-Mail to and from Motorola
- Data Sheet and Application Note faxing
- Consultants database
- On-Line Q&A
- OEM Price Book

The system runs on General Electric Information Systems (GEIS) worldwide network with local access throughout the U.S. and many other countries in Europe, Asia, North & South America and Australia.

The system operates over direct phone lines and PBX equipment. An 800 number is provided by GEIS for access problems and other connection related issues.

Minimum user system requirements:

- IBM compatible with 640K; HD with 3 MB available; DOS 3.3, CGA
- Macintosh Plus with 1 MB; HD with 3 MB available, System 6.0.5.
- Hayes-compatible Modem, and access to a phone line.

Order BR1307/D for more information or refer to the Business Reply Card in this document.

- Design-NET subscription fees are currently waived for qualified customers.

7

# Motorola Data and Application Literature

*Complete technical data for the world's most comprehensive inventory of semiconductor components*

To complement the industry's broadest line of semiconductor products, Motorola offers a complete library of Data books which detail the electrical characteristics of its products. These documents are supplemented by User's Manuals describing the capabilities of the products in circuit and system design.

Motorola attempts to fill the need for applications information concerning today's highly complex electronic components. Each year dozens of authors from colleges and

universities, and from the industry, add their individual contributions to the collective literature. From these, Motorola has selected a number of texts which add substantially to the comprehension and applications of some of the more complex products. By buying these in large quantities and providing them to customers at lower than retail cost, Motorola hopes to foster a more comprehensive acquaintance with these products at greatly reduced prices.

For complete summaries and prices, in the USA order BR101/D from the Literature Distribution Center and in Europe order BR464/D from the Literature Distribution Centre.

## Discrete Literature Data Books & Handbooks

**DL110/D**, RF Device Data  
**DL111/D**, Bipolar Power Transistor Data  
**DL118/D**, Optoelectronics Device Data  
**DL126/D**, Small-Signal Transistors, FETs and Diodes  
**DL135/D**, TMOS Power MOSFET Transistor Data  
**DL137/D**, Thyristor Device Data  
**DL148/D**, Discrete Military Operations Data  
**DL150/D**, TVS/Zener Device Data  
**DL151/D**, Rectifier Device Data  
**DL200/D**, Pressure Sensor Device Data  
**DL410/D**, Power Applications Manual  
**DL411/D**, Communications Applications Manual  
**DL413/D**, Radio, RF and Video Applications Manual  
**DL414/D**, FET Applications Manual  
**HB214/D**, Discrete Military Operation Handbook

## Brochures and Selector Guides

**BR904/D**, MIL-Processed Devices: Technical Data  
**BR923/D**, Communications, Power and Signal Technologies Group — Reliability Audit Report  
**SG46/D**, RF Products Selector Guide and Cross Reference  
**SG79/D**, Switchmode — A Designer's Guide for Switching Power Supply Circuits and Components  
**SG370/D**, Discrete Surface Mount Products Selector Guide

## Textbooks

**TB321/D**, Practical Switching Power Supply Design  
**TB326/D**, Radio Frequency Transistors — Principles & Practical Applications

## IC Literature

### Databooks & Handbooks

**BR1330/D**, ECLinPS Lite  
**BR1333/D**, Timing Solutions  
**BR1334/D**, Hipercomm  
**DL121/D**, FAST and LS TTL Data  
**DL122/D**, MECL Device Data  
**DL128/D**, Linear and Interface Integrated Circuits, Vol. 1 & 2

### IC Literature (continued)

**DL129/D**, High Speed CMOS Logic Data  
**DL131/D**, CMOS Logic Data  
**DL136/D**, Communications Device Data  
**DL138/D**, FACT Data  
**DL140/D**, ECLinPS Device Data  
**DL144/D**, Commercial Plus and MIL/Aero Applications Memory Products  
**DL145/D**, Military MECL Family Data  
**DL152/D**, MDA15 CMOS Standard Cell Data  
**DL154/D**, MDA08 CMOS Standard Cell Data  
**DL155/D**, Dynamic RAM Data  
**DL156/D**, FAST Static RAM BiCMOS, CMOS, and Module Data  
**DL408/D**, 8-Bit MCU Applications Manual  
**DL409/D**, 16/32-Bit Applications Manual  
**DL411/D**, Communications Applications Manual  
**DL412/D**, Industrial Control Applications Manual  
**HB205/D**, MECL System Design Handbook  
**M68000FR/AD**, M68000 Family Reference

## Brochures and Selector Guides

**BR1100/D**, Semiconductor Products Sector Reliability and Quality Report  
**BR1112/D**, M68HC05 & M68HC08 Family Customer Specified Integrated Circuit (CSIC) Microcontroller Unit (MCU) Literature  
**BR1133/D**, High-Performance Internal Product Portfolio Overview  
**SG138/D**, Commercial Plus and Mil/Aero Application IC and Discrete Selector Guide  
**SG146/D**, DSP Quarterly Update  
**SG165/D**, CSIC Microcontroller Quarterly Update  
**SG166/D**, Advanced Microcontroller Quarterly Update  
**SG167/D**, High Performance MPU Quarterly Update  
**SG169/D**, Mixed-Signal Solutions From MOS Digital — Analog IC Quarterly Update  
**SG171/D**, FAST Static RAM Quarterly Update  
**SG172/D**, Dynamic RAM Quarterly Update  
**SG96/D**, Linear and Interface Integrated Circuits Selector Guide and Cross-Reference  
**SG366/D**, TTL, ECL, CMOS, & Special Logic Circuits Selector Guide

7

## Motorola Data and Application Literature: IC Literature (continued)

### Microprocessor Manuals

**BR729/D**, The 68K Source – Third Party Vendor Catalog  
**DSP56000UM/AD**, DSP56000/DSP56001 Digital Signal Processor User's Manual  
**DSP56004UM/AD**, DSP56004 Digital Signal Processor User's Manual  
**DSP56100FM/AD**, DSP56100 Digital Signal Processor Family Manual  
**DSP56166UM/AD**, DSP56166 Digital Signal Processor User's Manual  
**DSP96002UM/AD**, DSP96002 IEEE Floating–Point Dual–Port Processor User's Manual  
**M6809PM/AD**, MC6809–MC6809E Microprocessor Programming Manual  
**M68000FR/AD**, M68000 Family Reference  
**M68000PM/AD**, M68000 Family Programmer's Reference Manual  
**M68000UM/AD**, M68000 8–/16–/32–Bit Microprocessors User's Manual  
**M68020UM/AD**, M68020 32–Bit Microprocessor User's Manual  
**M68040UM/AD**, M68040 32–Bit Third–Generation Microprocessor User's Manual  
**MC68EC030UM/AD**, 32–Bit Embedded Controller User's Manual  
**MC68030UM/AD**, MC68030 Enhanced 32–Bit MPU User's Manual, Third Edition  
**MC68302UM/AD**, MC68302 Integrated Multi–Protocol Processor User's Manual  
**MC68306UM/AD**, MC68306UM Integrated EC000 Processor User's Manual  
**MC68306UMAD/AD**, MC68306UMAD Errata and Added Information to MC68306 Integrated EC000 Processor User's Manual  
**MC68330UM/AD**, Modular Microcontroller Family MC68330 Integrated CPU Processor User's Manual  
**MC68331UM/AD**, Modular Microcontroller Family MC68331 User's Manual  
**MC68340UM/AD**, Modular Microcontroller Family MC68340 Integrated Processor with DMA User's Manual  
**MC68349UM/AD**, Dragon 1 High Performance Integrated Processor User's Manual  
**MC68488UM/AD**, MC68488 General Purpose Interface Adapter User's Manual  
**MC68605UM/AD**, MC68605 X.25 Protocol Controller User's Manual  
**MC68606UM/AD**, MC68606 Multi–Link LAPD Protocol Controller User's Manual  
**MC68824UM/AD**, MC68824 Token Bus Controller User's Manual  
**MC68836UM/AD**, MC68836 FDDI Clock Generator User's Manual

**MC68837UM/AD**, MC68837 FDDI Elasticity Buffer and Link Management User's Manual  
**MC68838UM/AD**, MC68838 FDDI Media Access Controller User's Manual  
**MC68840UM/AD**, Fiber Distributed Data Interface User's Manual  
**MC68851UM/AD**, MC68851 Paged Memory Management Unit User's Manual  
**MC68881UM/AD**, MC68881/MC68882 Floating–Point Coprocessor User's Manual  
**MC88100UM/AD**, MC88100 RISC Microprocessor User's Manual  
**MC88110UM/AD**, MC88110 Second–Generation RISC Microprocessor User's Manual  
**MC88200UM/AD**, MC88200 Cache/Memory Management Unit User's Manual  
**MC88410UM/AD**, MC88410 Secondary Cache Controller User's Manual  
**MPC601UM/AD**, PowerPC 601 RISC Microprocessor User's Manual

### Microcontroller Manuals

**ADCRM/AD**, Modular Microcontroller Family Analog–to–Digital Converter (ADC) Reference Manual  
**CPU08RM/AD**, M68HC08 Central Processor Unit Reference Manual  
**CPU16RM/AD**, Modular Microcontroller Family Central Processor Unit (CPU16) Reference Manual  
**CPU32RM/AD**, Modular Microcontroller Family Central Processor Unit (CPU32) Reference Manual  
**GPTRM/AD**, Modular Microcontroller Family General Purpose Timer (GPT) Reference Manual  
**LONUG/AD**, LonBuilder User's Guide  
**M68HC05AG/AD**, M68HC05 Applications Guide  
**M68HC11RM/AD**, M68HC11 Reference Manual  
**M68PCBUG11/D2**, M68HC11, PCBUG11 User's Manual  
**M6805UM/AD3**, M6805 HMOS/M146805 CMOS Family User's Manual  
**MC68HC05CxRG/AD**, MC68HC05Cx HCMOS Single–Chip Microcontrollers Programming Reference Guide  
**MC68HC11A8RG/AD**, MC68HC11A8 Programming Reference Guide  
**MC68HC11D3RG/AD**, MC68HC11D3 and MC68HC711D3 Programming Reference Guide  
**MC68HC11F1RG/AD**, MC68HC11F1 Programming Reference Guide  
**MC68HC11K4RG/AD**, MC68HC11K4 and MC68HC711K4 Programming Reference Guide  
**MC68HC11KA4RG/AD**, MC68HC11KA4 and MC68HC711KA4 Programming Reference Guide  
**MC68HC11L6RG/AD**, MC68HC11L6 and MC68HC711L6 Programming Reference Guide

7



## Motorola Data and Application Literature: IC Literature (continued)

### Microcontroller Manuals (continued)

**MC68HC16Z1UM/AD**, Modular Microcontroller Family MC68HC16Z1 User's Manual  
**MC68040DH/AD**, MC68040 Designer's Handbook  
**MC68332UM/AD**, Modular Microcontroller Family MC68332 User's Manual  
**MCCIRM/AD**, Modular Microcontroller Family Multichannel Communication Interface (MCCI) Reference Manual  
**NEURONCPG/AD**, Neuron C Programmer's Guide  
**QSMRM/AD**, Modular Microcontroller Family Queued Serial Module (QSM) Reference Manual  
**SIMRM/AD**, Modular Microcontroller Family System Integration Module (SIM) Reference Manual  
**TPURM/AD**, Modular Microcontroller Family Time Processor Unit (TPU) Reference Manual

### Textbooks

**TB301/D**, Basic Microprocessors and the 6800  
**TB303/D**, Using Microprocessors and Microcomputers: The 6800 Family  
**TB304/D**, Pascal Programming Structures for Motorola Microprocessors  
**TB309/D**, Programming the 6809  
**TB312/D**, Introduction to Integrated-Circuit Layout  
**TB313/D**, Efficient C  
**TB316/D**, Single- and Multi-Chip MCU Interfacing Lab Manual  
**TB316LMD**, Single- and Multi-Chip MCU Interfacing Lab Manual  
**TB317/D**, 68000, 68010, 68020 Primer  
**TB318/D**, Microprocessor Systems Design: 68000 Hardware, Software and Interfacing  
**TB319/D**, MC68000 Assembly Language and Systems Programming  
**TB320/D**, The 68000 Family, Volume 1: Architecture, Addressing Modes and Instruction Set  
**TB322/D**, The 68000 Family, Volume 2: Applications and

the M68000 Devices  
**TB323/D**, The 68000 Book  
**TB324/D**, Real Time Digital Signal Processing Applications with Motorola's DSP56000 Family  
**TB325/D**, The Motorola MC68332 Microcontroller  
**TB325LMD**, The Motorola MC68332 Microcontroller Lab Manual  
**TB327/D**, Using Small Microcontrollers

### ASIC Design Manuals

**BR165/D**, MCA800ECL/MCA2500ECL, Macrocell Array Design Manual  
**BR312/D**, MCA2800RAM and MCA2800ALS Macrocell Array Design Manual  
**BR916/D**, Packaging Manual for ASIC Arrays  
**BR1400/D**, OACS System Brochure  
**H4CDM/D**, H4C Series Design Reference Guide  
**H4CPDM/D**, H4CPlus Series Design Reference Guide  
**HDCDM/D**, HDC Series Design Manual  
**MCA3ECL/D**, MCA3 ECL Series Design Manual  
**MCA3ETLDM/D**, MCA3 ETL Design Manual  
**SG367/D**, ASIC Overview Guide

### General Literature

**BR128/D**, Semiconductor Data Update Magazine  
**BR135/D**, Applications Literature Catalog  
**BR518/D**, Reliability and Quality Handbook  
**BR1202/D**, Motorola Quality System Review Guidelines  
**BR1307/D**, Design Net - Electronic Link to Motorola  
**DK101/D**, Motorola Data Disk - Specs in Secs, DK101/D, DOS 5.25, Motorola Data Disk - Specs in Secs, No Longer Available - DK304/D (DOS 3.5) Is Offered As A Replacement  
**DK304/D**, Motorola Data Disk - Specs in Secs  
Dr. BuB, DSP Electronic Bulletin Board  
Freeware Line, Microcontroller Electronic Bulletin Board  
**SEMIVID/D**, Basic Semiconductor Videos  
**SG73/D**, Master Selection Guide

7

# Motorola Application Literature

*Semiconductors in theory and practice*

Application Notes, Engineering Bulletins and Article Reprints are part of a total information system to define the characteristics and applications of semiconductor devices. Motorola's library consists of more than 300 such documents dealing with the applications of all types of semiconductors from discrete power transistors to the most complex microprocessors. All are described in an Application Note Catalog available from our Literature Distribution Center.

Individual application notes, application reports, engineering bulletins and article reprints can also be ordered from our

Literature Distribution Center.

Contact the Literature Distribution Center for prices and ordering information. In addition, there may be an alternative document available in some countries, contact your local Motorola Sales Office.

For complete summaries and prices: in the U.S.A. order BR135/D from the Literature Distribution Center.

In Europe order SG410/D from the Literature Distribution Centre. An Application Manual Series is also available which includes the following:

DL408/D	8-bit MCU Applications Manual	DL412/D	Industrial Control Applications Manual
DL409/D	16/32-bit Applications Manual	DL413/D	Radio, RF and Video Applications Manual
DL411/D	Communications Applications Manual	DL414/D	FET Applications Manual

# Technical Training 1994

## Course Offerings on Instructor-led, Audio Cassette and Video Training

### MC68EC/000 Microprocessor

This is a 3-day course in which the student learns to design with the MC68000 and MC68EC000 microprocessors. Labs are a major part of the learning process; lecture and exercises are also part of the course.

### MC68EC/000 Family Programming

This is a 3-day course in which the student learns software design with the MC68000 and M68EC000 family of microprocessors. Labs are a major part of the learning process; lecture and exercises are also part of the course.

### MC68EC/020/030 Hardware

This is a 1-day course in which the student (with microprocessor experience) learns to design with the hardware of the MC68EC/020 and MC68EC/030 microprocessors. The course consists of lecture and exercises.

### MC68EC/040 Microprocessor

This is a 2-day course in which the student (with M68000 family experience) learns to design with the MC68040 and MC68EC040 CPU including instruction and data caches and memory management unit. The course consists of lecture and exercises.

### MC68302 Communications Controller

This is a 3-day course in which the student (with MC68000 experience) learns to design with the Systems Integration Block and Communications Processor of the MC68302. Labs are a major part of the learning process; lecture and exercises are also a part of the course.

### MC68331/332 Embedded Controller

This is a 3-day course in which a student (with MC68000 experience) learns to design with the CPU32, Queued Serial Module, System Integration Module and Timer Processor Unit (no microcoding) of the MC68332 or General Purpose Timer of the MC68331. Labs are a major part of the learning process; lecture and exercises are also a part of the course.

### MC68340 Integrated Processor

This is a 2-day course in which the student (with M68000 family experience) learns to design with the CPU32, DMA Channels, Timers, Serial I/O Module, and System Integration Module. Labs are a major part of the learning process; lecture and exercises are also a part of the course.

### MC68HC05 Microcontroller

This is a 3-day course in which the student (with micro-processor experience) learns to design with the MC68HC05 including the on-chip subsystems. Labs are a major part of the learning process; lecture and exercises are also a part of the course.

### MC68HC11 Microcontroller

This is a 3-day course in which the student (with microprocessor experience) learns to design with the MC68HC11 including the on-chip subsystems. Labs are a major part of the learning process; lecture and exercises are also a part of the course.

### MC68HC16 Microcontroller

This is a 3-day course in which the student (with microprocessor experience) learns to design with the CPU16, Queued Serial Module, System Integration Module, Analog-to-Digital Converter, and General Purpose Timer of the MC68HC16. Labs are a major part of the learning process; lecture and exercises are also a part of the course.

### DSP56100 Family

This is a 3-day course in which the student (with digital signal processing design experience) learns to design with the DSP56156 digital signal processor. The course consists of lecture and exercises.

### DSP56000/1 Digital Signal Processor

This is a 4-day course in which the student (with digital signal processing design experience) learns to design with the DSP56000/1 digital signal processor. The course consists of lecture, labs, and exercises.

### DSP96000 Digital Signal Processor

This is a 4-day course in which the student (with digital signal processing design experience) learns to design with the DSP96000 digital signal processor. The course consists of lecture and exercises.

### TPU Microcode

The TPU Microcode course is a 3-day lab-intensive course in which the student learns how to write microcode functions for the TPU. The course is approximately 50% lecture and exercises and 50% lab time.

7

## Technical Training 1994 (continued)

### MC68360 QUIC

This course covers the features and subsystems of the MC68360. An in-depth overview of all the subsystems of the MC68360 as well as a brief review of the MC68000 family architecture is provided. This course will address the design issues encountered while using the subsystems (CPU32+, Timers, serial channels, IDMA channels, chip selects, memory controller, PIP and the SPI) of the MC68360 in a typical application.

## Course Prerequisites

A student enrolling in the MC68HC11 or MC68HC16 course must meet the prerequisites of the course by understanding microprocessor fundamentals. Students who need to meet these requirements will receive a packet upon enrollment. The pre-work must be completed by course start date.

A student enrolling in the MC68302, MC68332 or MC68340 courses must meet the prerequisites of the course by understanding the MC68000 microprocessor. Students who need to meet these requirements will receive a packet upon enrollment. The pre-work must be completed by course start date.

### PowerPC

The PowerPC course provides a background for the entire PowerPC family. The course is built around the PowerPC Architecture specification, the guideline from which each PowerPC implementation (i.e. each processor) is built. Details of all publicly announced implementations are discussed.

### 1994 Prices

Phoenix — The tuition is \$400 per student.

Elsewhere in the USA — The tuition is \$900 per student.

### To Enroll

To enroll for all courses or for additional information, call T.T. at 602-897-3665.

### In-Plant Courses

Courses listed in this brochure can be taught at your facility and tailored to fit your needs. If your company needs in-plant training, please call 602-897-3665 to arrange a time.

## Technical Training 1994 (continued)

Not all courses described are scheduled in 1994. If you or your company has a special need for one of these courses, call us at (602) 897-3665 and we will make special arrangements. If you are outside the USA, contact your local Motorola Sales Office or Technical Training Center listed in this section.

Call 602-897-3665 for the latest copy  
of our Technical Training Catalog and class schedule.  
If you are outside of the USA, call your local Technical Training Center  
or Sales Office and ask for BR348/D.

## Technical Training Centers

### Regional Training Centers

#### Detroit

41700 Six Mile Road  
Nothville, MI 48167  
(313) 347-6800

#### Phoenix

2100 E. Elliot Road EL524  
Tempe, AZ 85284  
(602) 897-4172  
(800) 521-6274

### Worldwide Training Centers

#### Munich, Germany

Phone: (89) 92103-571

#### Kwai Chung, N.Y. Hong Kong

Phone: 0-223111

#### Madrid, Spain

Phone: 457 82 04

#### Solna, Sweden

Phone (8) 7348800

#### Vanves Cedex, France

Phone: (1) 40955900

#### Ramat, Israel

Phone: 972-3-7538222

#### Aylesbury, United Kingdom

Phone: (0296) 393312

#### Assago Milano, Italy

Phone: (39) 282201

7

## Audio Cassette Courses

### MC68000 Microprocessor/MTTA1/CC

#### Course description:

This course is an introduction to the MC68000. It covers the major features of the MC68000: pins and bus operation, programming model, addressing modes, instruction set and exception processing (including interrupts). Software and hardware examples are included.

#### Who should take this course:

The student should be familiar with memory concepts, binary numbers, hexadecimal number notation, binary arithmetic and standard logic operations. Experience with an 8-bit microprocessor, a 16-bit minicomputer, or a mainframe would be beneficial. After completion of this course, the student will have a working, technical knowledge of the MC68000.

#### Course content:

The course is composed of three audio cassette tapes containing approximately four and one-half hours of material. Course notes for the tapes and an MC68000 User's Manual are supplied to aid the student. A set of application notes and other helpful technical materials are also included. Each topic begins with clearly set objectives and continues with a comprehensive study of the subject, including self-evaluation exercises (answers are provided).

### MC68020 Microprocessor/MTTA2/CC

#### Course description:

This course is an introduction to the MC68020. It covers the major features of the MC68020: internal architecture, programming model, pins and bus operations, addressing modes, instruction set and exception processing.

#### Who should take this course:

The student should be familiar with MC68020. After completion of this course, the student will have a working, technical knowledge of the MC68020.

#### Course content:

The course is composed of three audio cassette tapes containing approximately four and one-half hours of material. Course notes for the tapes and an MC68020 User's Manual are supplied to aid the student. A set of application notes and other helpful technical materials are also included. Each topic begins with clearly stated objectives, continues with a comprehensive study of the subject and concludes with a set of self-evaluation exercises (answers are provided).

### MC68030 Microprocessor/MTTA3/CC

#### Course description:

This course is an introduction to the MC68030. It covers the major features of the MC68030: data cache, burst mode, synchronous bus and the internal Memory Management Unit.

#### Who should take this course:

This course assumes knowledge of the MC68000 and the MC68020. After completion of this course, the student will have a working, technical knowledge of the MC68030.

#### Course content:

The course is composed of three audio cassette tapes containing approximately three and one-half hours of material. Course notes for the tapes and an MC68030 User's Manual are supplied to aid the student. Each topic begins with clearly stated objectives and continues with a comprehensive study of the subject, including self-evaluation exercises (answers are provided).

### DSP56000/1 Microprocessor/MTTA5/CC

#### Course description:

This course contains a brief overview of general Digital Signal Processing concepts. The main course content covers specifics of the DSP56000 and DSP5601 including the following: internal architecture and programming model, pins and buses, general addressing modes, general instruction set, exception processing, on-chip I/O, plus the DSP instructions and addressing modes.

#### Who should take this course:

The student should be familiar with memory concepts, binary numbers, hexadecimal number notation, binary arithmetic, standard logic operations and analog signal processing. After completion of this course, the student will have a working, technical knowledge of the DSP56000/1.

#### Course content:

The course is composed of three audio cassette tapes containing approximately four and one-half hours of material. Each topic has stated objectives and self-evaluation exercises with answers.

7

Cassettes are available through Literature Distribution Center – call (602) 994-6561 or 1-800-441-2447

## Audio Cassette Courses (continued)

### MC88100/MC88200/MTTA6/CC

#### Course description:

This course is an introduction to the MC88100/MC88020. This course covers: pins and registers, exception processing (including interrupts), addressing modes, instruction set, cache and Memory Management Unit.

#### Who should take this course:

Experience with a 16/32-bit microprocessor or mainframe is required. After completing the course, the student will have a working, technical knowledge of the MC88100/MC88200.

#### Course content:

The course is composed of three audio cassette tapes containing approximately four and one-half hours of material. Course notes for the tapes are supplied to aid the student. Each topic begins with clearly stated objectives and continues with a comprehensive study of the subject including self-evaluation exercises (answers are provided).

## Video Training

### Basic Semiconductor Videos

This brand new video training program "Motorola and the Semiconductor Universe" is a four part video program covering basic electronics and semiconductors for non-technical people. It is designed for Motorolans who are in support, administrative, and sales roles who are not EEs, but are involved in the daily business of serving SPS customers. It will also be ideal for our authorized distributors and direct customer buyers who would like to know more about the products they are purchasing. The series was produced by the Sales and Marketing Training Department.

The program is designed to answer the following questions:

- Why are we in business – what is the benefit to the customer?
- What do we make, and how do we make it?
- How do our products work?

- How are our products used by the customer, and where do they use them?
- What do our products do to provide specific customer solutions in their products?

The program uses many "real-life" examples and analogies. It graphically shows, through video animation and live footage, how electrons and the products we build to control them affect our everyday lives. The program includes supportive written material and is designed in a four part series:

- Part 1 – "The Fundamentals"
- Part 2 – "Discretes"
- Part 3 – "Integrated Circuits"
- Part 4 – "Microprocessors and Microcontrollers", including Memories.

The order number for this training program is SEMIVID/D and it can be ordered from the Literature Distribution Center for \$100.

**Cassettes and videos are available through Literature Distribution Center – call (602) 994-6561 or 1-800-441-2447**

# Device Index and Subject Index

---

## In Brief . . .

### Device Index

The following index lists the device numbers of the products contained in this selector guide and references the page number where each device is described in greater detail.<sup>(1)</sup> The listing is in a numeric sequence organized in a "computer sort." This means that all the devices listed herein follow a 39 character alphabet. This "new" alphabet starts with a Period, a Dash and a Slash (.-/), followed by the 26 letter alphabet (A thru Z), which is then followed by 10 numbers (0 thru 9).

The ranking or hierarchy of this 39 character alphabet is as follows:

.- / A B C D E F G H I J K L M N O P Q R S T U V W X  
Y Z 0 1 2 3 4 5 6 7 8 9

Therefore, if you are looking for a device starting with a letter of the alphabet like an MC1741CP, it would appear before a device starting with a number, such as 2N1132.

To find a device in this index, start with the first character of the device and find that section of the index; next move to the second character in the device number, and move to that character within the same portion of the listing; and so on until the device number is found. In other words, it is used just like a dictionary, character by character.

For example, to find the 2N6837, go to that section of the listing that begins with the number "2" (Notice that the section follows all devices that begin with a letter of the alphabet or "1"). Next, find that portion of the listing that begins with "2N" (Notice it follows those devices that begin with "2K"). Next, find that portion of the listing that begins with "2N6" (Notice it follows those devices that begin with "2N5"). Continue looking for those portions that begin with the next consecutive character until you have found the entire number.

Because of the way "Computer Sort" works it is not necessary to be concerned with the absolute value or number of characters in a part number, just move across the device part number, left to right, one character at a time until you find the number.

### Subject Index

This listing is intended to simplify the identification of products where specific device numbers are not known.

	Page
Device Index .....	8.1-1
General Index .....	8.2-1
Subject Index .....	8.2-8

<sup>(1)</sup> The device numbers contained in this index are for reference only and do not necessarily represent the complete device number necessary to order the device. Contact your local Sales Office or Authorized Distributor for complete ordering information.





# Device Index

AM26LS30	4.6-6	BC368	5.1-4	BC848ALT1	5.1-10
AM26LS31	4.6-5, 4.6-6	BC369	5.1-4	BC848BLT1	5.1-10
AM26LS32	4.6-6	BC373	5.1-4	BC848CLT1	5.1-10
AM26L532	4.6-6	BC489	5.1-4	BC856ALT1	5.1-10
ATV6031	5.10-26	BC490	5.1-4	BC856BLT1	5.1-10
ATV6060	5.10-26	BC517	5.1-4	BC857ALT1	5.1-11
BAL99LT1	5.1-35	BC546	5.1-2	BC857BLT1	5.1-11
BAS116LT1	5.1-36	BC546A	5.1-2	BC858ALT1	5.1-11
BAS16LT1	5.1-35	BC546B	5.1-2	BC858BLT1	5.1-11
BAS16WT1	5.1-35	BC547	5.1-2	BC858CLT1	5.1-11
BAS21LT1	5.1-35	BC547A	5.1-2	BDB01C	5.1-3
BAV170LT1	5.1-36	BC547B	5.1-2	BDB01D	5.1-3
BAV199LT1	5.1-36	BC547C	5.1-2	BDB02C	5.1-3
BAV70LT1	5.1-36	BC548	5.1-2	BDB02D	5.1-3
BAV70WT1	5.1-36	BC548A	5.1-2	BDC01D	5.1-3
BAV74LT1	5.1-36	BC548B	5.1-2	BDC02D	5.1-3
BAV99LT1	5.1-36	BC548C	5.1-2	BDC05	5.1-5
BAW156LT1	5.1-36	BC549B	5.1-3	BDV64B	5.5-7
BAW156LT1	5.1-36	BC549C	5.1-3	BDV65B	5.5-7
BAW56LT1	5.1-36	BC550B	5.1-3	BDW42	5.5-7
BAW56WT1	5.1-36	BC550C	5.1-3	BDW47	5.5-7
BCP53T1	5.1-15	BC556	5.1-2	BDX33B	5.5-6
BCP56T1	5.1-15	BC556A	5.1-2	BDX33C	5.5-7
BCP68T1	5.1-16	BC556B	5.1-2	BDX34B	5.5-6
BCP69T1	5.1-16	BC557	5.1-2	BDX34C	5.5-7
BCY58-VIII	5.1-17	BC557A	5.1-2	BDX53B	5.5-6
BCY59-IX	5.1-17	BC557B	5.1-2	BDX53C	5.5-6
BCY59-VIII	5.1-17	BC557C	5.1-2	BDX54B	5.5-6
BCY59B/NBP	6.4-29	BC558B	5.1-2	BDX54C	5.5-6
BCY79-IX	5.1-17	BC559B	5.1-3	BDX66AA/NBP	6.4-29
BCY79-VIII	5.1-17	BC559C	5.1-3	BDX67AA/NBP	6.4-29
BCY79B/NBP	6.4-29	BC560B	5.1-3	BD135	5.5-11
BC107	5.1-17	BC560C	5.1-3	BD136	5.5-11
BC107A	5.1-17	BC618	5.1-4	BD137	5.5-11
BC107B	5.1-17	BC639	5.1-4	BD138	5.5-11
BC107B/NBP	6.4-29	BC640	5.1-4	BD139	5.5-11
BC109C	5.1-17	BC807-16LT1	5.1-10	BD140	5.5-11
BC177B	5.1-17	BC807-25LT1	5.1-11	BD140.10	5.5-11
BC182	5.1-2	BC807-40LT1	5.1-11	BD157	5.5-10
BC212	5.1-2	BC817-16LT1	5.1-10	BD158	5.5-10
BC237B	5.1-2	BC817-25LT1	5.1-10	BD159	5.5-11
BC239	5.1-3	BC817-40LT1	5.1-10	BD165	5.5-11
BC307B	5.1-2	BC846ALT1	5.1-10	BD166	5.5-11
BC327	5.1-2	BC846BLT1	5.1-10	BD169	5.5-11
BC328	5.1-2	BC847ALT1	5.1-10	BD179	5.5-11
BC337	5.1-2	BC847BLT1	5.1-10	BD180	5.5-11
BC338	5.1-2	BC847CLT1	5.1-10	BD237	5.5-11

# Device Index

BD238	5.5-11	BFR92LT1	5.1-15	BSS76B/NBP	6.4-29
BD241B	5.5-4	BFR93ALT1	5.10-16	BSS89	5.1-22
BD241C	5.5-4	BFR93LT1	5.1-15	BSV52LT1	5.1-12
BD242B	5.5-4	BFR96	5.10-16, 5.10-19	BSX20	5.1-19
BD242C	5.5-4	BFS17LT1	5.10-16	BSX52BB/NBP	6.4-29
BD243B	5.5-5	BFS17LT1	5.1-15	BS107	5.1-22
BD243BA/NBP	6.4-29	BFY90X/NBP	6.4-31	BS107A	5.1-22
BD243C	5.5-5	BF199	5.1-6	BS170	5.1-22
BD244B	5.5-5	BF224	5.1-6	BUL146	5.5-5
BD244BA/NBP	6.4-29	BF246A	5.1-21	BUL146F	5.5-3
BD244C	5.5-5	BF246B	5.1-21	BUL147	5.5-6
BD249C	5.5-8	BF393	5.1-5	BUL147F	5.5-3
BD250C	5.5-8	BF420	5.1-5	BUL44	5.5-4
BD437	5.5-11	BF421	5.1-5	BUL44F	5.5-3
BD438	5.5-11	BF422	5.1-5	BUL45	5.5-5
BD440	5.5-11	BF423	5.1-5	BUL45F	5.5-3
BD441	5.5-11	BF493S	5.1-5	BUS48A/NBP	6.4-29
BD442	5.5-11	BF720T1	5.1-16	BUS50	5.5-17
BD677	5.5-11	BF721T1	5.1-16	BUS50A/NBP	6.4-29
BD677A	5.5-11	BF844	5.1-5	BUS98	5.5-16
BD678	5.5-11	BF959	5.1-6	BUS98A	5.5-16
BD678A	5.5-11	BRX44-30	5.7-2	BUS98AA/NBP	6.4-29
BD679	5.5-11	BRX45-60	5.7-2	BUT11AF	5.5-3
BD679A	5.5-11	BRX46-100	5.7-2	BUT33	5.5-17
BD680	5.5-11	BRX47-200	5.7-2	BUT34	5.5-17
BD680A	5.5-11	BRX49-400	5.7-2	BUT51P	5.5-8
BD681	5.5-12	BRY55-30	5.7-2	BUV11	5.5-15
BD682	5.5-12	BRY55-60	5.7-2	BUV11A/NBP	6.4-29
BD776	5.5-11	BRY55-100	5.7-2	BUV18A	5.5-17
BD777	5.5-11	BRY55-200	5.7-2	BUV20	5.5-16
BD778	5.5-11	BRY55-400	5.7-2	BUV21	5.5-16
BD779	5.5-12	BRY55-500	5.7-2	BUV22	5.5-16
BD780	5.5-12	BRY55-600	5.7-2	BUV23	5.5-16
BD787	5.5-11	BSP16T1	5.1-16	BUV48	5.5-8
BD788	5.5-11	BSP19AT1	5.1-16	BUV48A	5.5-8
BD789	5.5-11	BSP20AT1	5.1-16	BUV60	5.5-16
BD790	5.5-11	BSP52T1	5.1-16	BUX10A/NBP	6.4-29
BD791	5.5-12	BSP62T1	5.1-16	BUX20A/NBP	6.4-29
BD792	5.5-12	BSS123LT1	5.1-24	BUX39	5.5-16
BD801	5.5-5	BSS51 B/NBP	6.4-29	BUX41	5.5-14
BD802	5.5-5	BSS63LT1	5.1-14	BUX48	5.5-15
BD808	5.5-6	BSS64LT1	5.1-14	BUX48A	5.5-15
BD809	5.5-6	BSS71 B/NBP	6.4-29	BUX48A/NBP	6.4-29
BD810	5.5-6	BSS73	5.1-18	BUX85	5.5-4
BFR90	5.10-19	BSS73B/NBP	6.4-29	BUX98	5.5-16
BFR90	5.10-16	BSS74B/NBP	6.4-29	BUX98A	5.5-16
BFR92ALT1	5.10-16	BSS76	5.1-18	BUY49P	5.5-11

# Device Index

BUZ11	5.4-9	BZX55C24RL	5.2-17	BZX79C12RL	5.2-16
BUZ11A	5.4-9	BZX55C27RL	5.2-17	BZX79C120RL	5.2-17
BUZ71	5.4-9	BZX55C3V0A/NBP	6.4-31	BZX79C13RL	5.2-16
BUZ71A	5.4-9	BZX55C3V0RL	5.2-16	BZX79C130RL	5.2-17
BUZ84A	5.4-13	BZX55C3V3A/NBP	6.4-31	BZX79C15RL	5.2-16
BU208A	5.5-13	BZX55C3V3RL	5.2-16	BZX79C150RL	5.2-17
BU323A	5.5-14	BZX55C3V6RL	5.2-16	BZX79C16RL	5.2-16
BU323AP	5.5-7	BZX55C3V9A/NBP	6.4-31	BZX79C160RL	5.2-17
BU406,D	5.5-5	BZX55C3V9RL	5.2-16	BZX79C18RL	5.2-16
BU407,D	5.5-5	BZX55C30A/NBP	6.4-31	BZX79C180RL	5.2-17
BU508A	5.5-7, 5.5-20	BZX55C30RL	5.2-17	BZX79C2V4RL	5.2-16
BU522B	5.5-5	BZX55C33A/NBP	6.4-31	BZX79C2V7RL	5.2-16
BU806	5.5-6	BZX55C33RL	5.2-17	BZX79C20RL	5.2-17
BYS35-45X/NBP	6.4-32	BZX55C36A/NBP	6.4-31	BZX79C200RL	5.2-17
BYS35-50/NBP	6.4-32	BZX55C36RL	5.2-17	BZX79C22RL	5.2-17
BYS60-45X/NBP	6.4-32	BZX55C39RL	5.2-17	BZX79C24RL	5.2-17
BYS75-45X/NBP	6.4-32	BZX55C4V3RL	5.2-16	BZX79C27RL	5.2-17
BYS75-50X/NBP	6.4-32	BZX55C4V7A/NBP	6.4-31	BZX79C27RL	5.2-17
BYT230PIV-1000M	5.6-13	BZX55C4V7RL	5.2-16	BZX79C3V0RL	5.2-16
BYT230PIV-400M	5.6-13	BZX55C43RL	5.2-17	BZX79C3V3RL	5.2-16
BYT261PIV-1000M	5.6-13	BZX55C47RL	5.2-17	BZX79C3V6RL	5.2-16
BYT261PIV-400M	5.6-13	BZX55C5V1A/NBP	6.4-31	BZX79C3V9RL	5.2-16
BYW77-150X/NBP	6.4-32	BZX55C5V1RL	5.2-16	BZX79C30RL	5.2-17
BYW77-200X/NBP	6.4-32	BZX55C5V6A/NBP	6.4-31	BZX79C33RL	5.2-17
BZX55C10A/NBP	6.4-31	BZX55C5V6RL	5.2-16	BZX79C36RL	5.2-17
BZX55C10RL	5.2-16	BZX55C51RL	5.2-17	BZX79C39RL	5.2-17
BZX55C11A/NBP	6.4-31	BZX55C56RL	5.2-17	BZX79C4V3RL	5.2-16
BZX55C11RL	5.2-16	BZX55C6V2A/NBP	6.4-31	BZX79C43RL	5.2-17
BZX55C12A/NBP	6.4-31	BZX55C6V2RL	5.2-16	BZX79C47RL	5.2-17
BZX55C12RL	5.2-16	BZX55C6V8A/NBP	6.4-31	BZX79C47RL	5.2-17
BZX55C13A/NBP	6.4-31	BZX55C6V8RL	5.2-16	BZX79C5V1RL	5.2-16
BZX55C13RL	5.2-16	BZX55C62A/NBP	6.4-31	BZX79C5V6RL	5.2-16
BZX55C15A/NBP	6.4-31	BZX55C62RL	5.2-17	BZX79C51RL	5.2-17
BZX55C15RL	5.2-16	BZX55C68RL	5.2-17	BZX79C56RL	5.2-17
BZX55C16A/NBP	6.4-31	BZX55C7V5A/NBP	6.4-32	BZX79C6V2RL	5.2-16
BZX55C16RL	5.2-16	BZX55C7V5RL	5.2-16	BZX79C6V8RL	5.2-16
BZX55C18A/NBP	6.4-31	BZX55C75RL	5.2-17	BZX79C62RL	5.2-17
BZX55C18RL	5.2-16	BZX55C8V2A/NBP	6.4-32	BZX79C68RL	5.2-17
BZX55C2V4A/NBP	6.4-31	BZX55C8V2RL	5.2-16	BZX79C7V5RL	5.2-16
BZX55C2V4RL	5.2-16	BZX55C82RL	5.2-17	BZX79C75RL	5.2-17
BZX55C2V7A/NBP	6.4-31	BZX55C9V1A/NBP	6.4-32	BZX79C8V2RL	5.2-16
BZX55C2V7RL	5.2-16	BZX55C9V1RL	5.2-16	BZX79C82RL	5.2-17
BZX55C20A/NBP	6.4-31	BZX55C91RL	5.2-17	BZX79C9V1RL	5.2-16
BZX55C20RL	5.2-17	BZX79C10RL	5.2-16	BZX79C91RL	5.2-17
BZX55C22A/NBP	6.4-31	BZX79C100RL	5.2-17	BZX83C10RL	5.2-16
BZX55C22RL	5.2-17	BZX79C11RL	5.2-16	BZX83C11RL	5.2-16
BZX55C24A/NBP	6.4-31	BZX79C110RL	5.2-17	BZX83C12RL	5.2-16
				BZX83C13RL	5.2-16

# Device Index

BZX83C15RL	5.2-16	BZX84C47LT1	5.2-22, 5.2-24	BZX85C36A/NBP	6.4-31
BZX83C16RL	5.2-16	BZX84C5V1LT1	5.2-21, 5.2-24	BZX85C36RL	5.2-18
BZX83C18RL	5.2-16	BZX84C5V6LT1	5.2-21, 5.2-24	BZX85C39A/NBP	6.4-31
BZX83C2V7RL	5.2-16	BZX84C51LT1	5.2-22, 5.2-24	BZX85C39RL	5.2-18
BZX83C20RL	5.2-17	BZX84C56LT1	5.2-22, 5.2-24	BZX85C4V3RL	5.2-18
BZX83C22RL	5.2-17	BZX84C6V2LT1	5.2-21, 5.2-24	BZX85C4V7A/NBP	6.4-31
BZX83C24RL	5.2-17	BZX84C6V8LT1	5.2-21, 5.2-24	BZX85C4V7RL	5.2-18
BZX83C27RL	5.2-17	BZX84C62LT1	5.2-22, 5.2-24	BZX85C43RL	5.2-18
BZX83C3V0RL	5.2-16	BZX84C68LT1	5.2-22, 5.2-24	BZX85C47RL	5.2-18
BZX83C3V3RL	5.2-16	BZX84C7V5LT1	5.2-21, 5.2-24	BZX85C5V1A/NBP	6.4-31
BZX83C3V6RL	5.2-16	BZX84C75LT1	5.2-22, 5.2-24	BZX85C5V1RL	5.2-18
BZX83C3V9RL	5.2-16	BZX84C8V2LT1	5.2-21, 5.2-24	BZX85C5V6A/NBP	6.4-31
BZX83C30RL	5.2-17	BZX84C9V1LT1	5.2-21, 5.2-24	BZX85C5V6RL	5.2-18
BZX83C33RL	5.2-17	BZX85C10A/NBP	6.4-32	BZX85C51RL	5.2-18
BZX83C4V3RL	5.2-16	BZX85C10RL	5.2-18	BZX85C56A/NBP	6.4-31
BZX83C4V7RL	5.2-16	BZX85C100A/NBP	6.4-32	BZX85C56RL	5.2-18
BZX83C5V1RL	5.2-16	BZX85C100RL	5.2-19	BZX85C6V2A/NBP	6.4-31
BZX83C5V6RL	5.2-16	BZX85C11A/NBP	6.4-32	BZX85C6V2RL	5.2-18
BZX83C6V2RL	5.2-16	BZX85C11RL	5.2-18	BZX85C6V8A/NBP	6.4-31
BZX83C6V8RL	5.2-16	BZX85C12A/NBP	6.4-32	BZX85C6V8RL	5.2-18
BZX83C7V5RL	5.2-16	BZX85C12RL	5.2-18	BZX85C62A/NBP	6.4-31
BZX83C8V2RL	5.2-16	BZX85C13A/NBP	6.4-32	BZX85C62RL	5.2-18
BZX83C9V1RL	5.2-16	BZX85C13RL	5.2-18	BZX85C68RL	5.2-18
BZX84C10LT1	5.2-21, 5.2-24	BZX85C15A/NBP	6.4-32	BZX85C7V5A/NBP	6.4-31
BZX84C11LT1	5.2-21, 5.2-24	BZX85C15RL	5.2-18	BZX85C7V5RL	5.2-18
BZX84C12LT1	5.2-21, 5.2-24	BZX85C16A/NBP	6.4-31	BZX85C75RL	5.2-19
BZX84C13LT1	5.2-21, 5.2-24	BZX85C16RL	5.2-18	BZX85C8V2A/NBP	6.4-31
BZX84C15LT1	5.2-21, 5.2-24	BZX85C18A/NBP	6.4-31	BZX85C8V2RL	5.2-18
BZX84C16LT1	5.2-21, 5.2-24	BZX85C18RL	5.2-18	BZX85C82A/NBP	6.4-31
BZX84C18LT1	5.2-21, 5.2-24	BZX85C20A/NBP	6.4-31	BZX85C82RL	5.2-19
BZX84C2V4LT1	5.2-21, 5.2-24	BZX85C20RL	5.2-18	BZX85C9V1A/NBP	6.4-31
BZX84C2V7LT1	5.2-21, 5.2-24	BZX85C22A/NBP	6.4-31	BZX85C9V1RL	5.2-18
BZX84C20LT1	5.2-21, 5.2-24	BZX85C22RL	5.2-18	BZX85C91RL	5.2-19
BZX84C22LT1	5.2-21, 5.2-24	BZX85C24A/NBP	6.4-31	CA2810C	5.10-30
BZX84C24LT1	5.2-21, 5.2-24	BZX85C24RL	5.2-18	CA2810CS	5.10-30
BZX84C27LT1	5.2-21, 5.2-24	BZX85C27A/NBP	6.4-31	CA2818C	5.10-30
BZX84C3V0LT1	5.2-21, 5.2-24	BZX85C27RL	5.2-18	CA2818CS	5.10-30
BZX84C3V3LT1	5.2-21, 5.2-24	BZX85C3V3A/NBP	6.4-31	CA2830C	5.10-30
BZX84C3V6LT1	5.2-21, 5.2-24	BZX85C3V3RL	5.2-18	CA2830CS	5.10-30
BZX84C3V9LT1	5.2-21	BZX85C3V6A/NBP	6.4-31	CA2832C	5.10-30
BZX84C30LT1	5.2-22, 5.2-24	BZX85C3V6RL	5.2-18	CA2832CS	5.10-30
BZX84C33LT1	5.2-22, 5.2-24	BZX85C3V9A/NBP	6.4-31	CA2833C	5.10-30
BZX84C36LT1	5.2-22, 5.2-24	BZX85C3V9RL	5.2-18	CA2833CS	5.10-30
BZX84C39LT1	5.2-22, 5.2-24	BZX85C30A/NBP	6.4-31	CA2842C	5.10-30
BZX84C4V3LT1	5.2-21, 5.2-24	BZX85C30RL	5.2-18	CA2842CS	5.10-30
BZX84C4V7LT1	5.2-21, 5.2-24	BZX85C33A/NBP	6.4-31	CA3059	4.3-2
BZX84C43LT1	5.2-22, 5.2-24	BZX85C33RL	5.2-18	CA3079	4.3-2

# Device Index

CA3146	4.8-5	C106B	5.7-3	DSP56002ADM	2.1-7
CA3146D	4.11-2	C106D	5.7-3	DSP56002ADSA	2.1-7
CA4800C	5.10-30	C106F	5.7-3	DSP56002ADSB	2.1-7
CA4800CS	5.10-30	C106M	5.7-3	DSP56002ADSF	2.1-7
CA4812C	5.10-30	C122A1	5.7-4	DSP56002FC40	2.1-4
CA4812CS	5.10-30	C122B1	5.7-4	DSP56002RC40	2.1-4
CA4815C	5.10-30	C122D1	5.7-4	DSP56004ADM	2.1-7
CA4815CS	5.10-30	C122F1	5.7-4	DSP56004ADSA	2.1-7
CA5800C	5.10-30	C122M1	5.7-4	DSP56004ADSB	2.1-7
CA5800CS	5.10-30	C122N1	5.7-4	DSP56004ADSF	2.1-7
CA5801	5.10-30	DAC-08	4.5-3	DSP56004AIB	2.1-7
CA5801S	5.10-30	DAC-08CD	4.11-2	DSP56100ADSA	2.1-7
CA5815C	5.10-30	DAC-08ED	4.11-2	DSP56100ADSB	2.1-7
CA5815CS	5.10-30	DSPCOMMAND	2.1-7	DSP56100ADSF	2.1-7
CA901	5.10-29	DSPMACHOST	2.1-7	DSP56100CLASA	2.1-8
CA901A	5.10-29	DSPPCHOST	2.1-7	DSP56100CLASB	2.1-8
CA902	5.10-29	DSPSUN4HOST	2.1-7	DSP56100CLASF	2.1-8
CA902A	5.10-29	DSP56ADC16S	2.1-6	DSP56156ADM	2.1-7
CA912	5.10-29	DSP56ICCCA	2.1-9	DSP56401FN	2.1-6
CA912A	5.10-29	DSP56ICCCF	2.1-9	DSP96KCCA	2.1-9
CA922	5.10-29	DSP56KCCA	2.1-9	DSP96KCCF	2.1-9
CA922A	5.10-29	DSP56KCCAJ	2.1-9	DSP96000ADM	2.1-7
CA97901	5.10-27	DSP56KCCF	2.1-9	DSP96000ADSA	2.1-7
CNX35	5.8-6	DSP56KCCFJ	2.1-9	DSP96000ADSB	2.1-7
CNX35F	5.8-9	DSP56KT2A	2.1-7	DSP96000ADSF	2.1-7
CNX35S	5.8-9	DSP56KT2B	2.1-7	DSP96000CLASA	2.1-8
CNX36	5.8-6	DSP56KT2F	2.1-7	DSP96000CLASB	2.1-8
CNX36F	5.8-9	DSP56L002FC40	2.1-4	DSP96000CLASF	2.1-8
CNX36S	5.8-9	DSP56000ADM	2.1-7	DS0026	4.2-17
CNX82	5.8-6	DSP56000ADSA	2.1-7	D44C12	5.5-5
CNX82F	5.8-10	DSP56000ADSB	2.1-7	D44E3	5.5-6
CNX82S	5.8-10	DSP56000ADSF	2.1-7	D44H10	5.5-6
CNX83	5.8-6	DSP56000CLASA	2.1-8	D44H11	5.5-6
CNX83F	5.8-9	DSP56000CLASB	2.1-8	D44H8	5.5-6
CNX83S	5.8-9	DSP56000CLASF	2.1-8	D44VH10	5.5-7
CNY17-1	5.8-6	DSP56000FC20	2.1-4	D45C12	5.5-5
CNY17-1F	5.8-9	DSP56000FE20	2.1-4	D45H10	5.5-6
CNY17-1S	5.8-9	DSP56000RC20	2.1-4	D45H11	5.5-6
CNY17-2	5.8-6	DSP56001FC20	2.1-4	D45H8	5.5-6
CNY17-2F	5.8-9	DSP56001FC27	2.1-4	D45VH10	5.5-7
CNY17-2S	5.8-9	DSP56001FC33	2.1-4	HDC003	1.1-3
CNY17-3	5.8-6	DSP56001FE20	2.1-4	HDC006	1.1-3
CNY17-3F	5.8-9	DSP56001FE27	2.1-4	HDC008	1.1-3
CNY17-3S	5.8-9	DSP56001FE33	2.1-4	HDC011	1.1-3
CR2428	5.10-30	DSP56001RC20	2.1-4	HDC016	1.1-3
CR3428	5.10-30	DSP56001RC27	2.1-4	HDC027	1.1-3
C106A	5.7-3	DSP56001RC33	2.1-4	HDC031	1.1-3

# Device Index

HDC049	1.1-3	H11B1F	5.8-10	H4C035	1.1-4
H11AA1	5.8-7	H11B1S	5.8-10	H4C057	6.2-28
H11AA1F	5.8-10	H11B2	5.8-7	H4C057	1.1-4
H11AA1S	5.8-10	H11B2F	5.8-10	H4C086	6.2-28
H11AA2	5.8-7	H11B2S	5.8-10	H4C086	1.1-4
H11AA2F	5.8-10	H11B255	5.8-7	H4C123	6.2-28
H11AA2S	5.8-10	H11B255F	5.8-10	H4C123	1.1-4
H11AA3	5.8-7	H11B255S	5.8-10	H4C161	6.2-28
H11AA3F	5.8-10	H11D1	5.8-8	H4C161	1.1-4
H11AA3S	5.8-10	H11D1F	5.8-11	H4C195	6.2-28
H11AA4	5.8-7	H11D1S	5.8-11	H4C195	1.1-4
H11AA4F	5.8-10	H11D2	5.8-8	H4C267	6.2-28
H11AA4S	5.8-10	H11D2F	5.8-11	H4C267	1.1-4
H11AV1	5.8-6	H11D2S	5.8-11	H4C318	6.2-28
H11AV1F	5.8-9	H11G1	5.8-7	H4C318	1.1-4
H11AV1S	5.8-9	H11G1F	5.8-11	ICTE-10	5.2-6
H11AV2	5.8-6	H11G1S	5.8-11	ICTE-10C	5.2-6
H11AV2F	5.8-9	H11G2	5.8-7	ICTE-12	5.2-6
H11AV2S	5.8-9	H11G2F	5.8-11	ICTE-12C	5.2-6
H11AV3	5.8-6	H11G2S	5.8-11	ICTE-15	5.2-6
H11AV3F	5.8-9	H11G3	5.8-7	ICTE-15C	5.2-6
H11AV3S	5.8-9	H11G3S	5.8-11	ICTE-18	5.2-6
H11A1	5.8-6	H11L1	5.8-8	ICTE-18C	5.2-6
H11A1F	5.8-9	H11L1F	5.8-12	ICTE-22	5.2-6
H11A1S	5.8-9	H11L1S	5.8-12	ICTE-22C	5.2-6
H11A2	5.8-6	H11L2	5.8-8	ICTE-36	5.2-6
H11A2F	5.8-9	H11L2F	5.8-11	ICTE-36C	5.2-6
H11A2S	5.8-9	H11L2S	5.8-12	ICTE-45	5.2-6
H11A3	5.8-6	H21A1	5.8-15	ICTE-45C	5.2-6
H11A3F	5.8-9	H21A2	5.8-15	ICTE-5	5.2-6
H11A3S	5.8-9	H21A3	5.8-15	ICTE-8	5.2-6
H11A4	5.8-6	H21B1	5.8-15	ICTE-8C	5.2-6
H11A4F	5.8-9	H22A1	5.8-15	IRFZ20	5.4-9
H11A4S	5.8-9	H22A2	5.8-15	IRFZ30	5.4-9
H11A5	5.8-6	H22A3	5.8-15	IRFZ44	5.4-9
H11A5F	5.8-9	H22B1	5.8-15	IRF130	5.4-13
H11A5S	5.8-9	H4CP028	1.1-5	IRF130A/NBP	6.4-30
H11A5100	5.8-6	H4CP048	1.1-5	IRF140	5.4-13
H11A5100F	5.8-9	H4CP075	1.1-5	IRF140A/NBP	6.4-30
H11A5100S	5.8-9	H4CP109	1.1-5	IRF150	5.4-13
H11A520	5.8-6	H4CP146	1.1-5	IRF150A/NBP	6.4-30
H11A520F	5.8-9	H4CP178	1.1-5	IRF230	5.4-13
H11A520S	5.8-9	H4C018	6.2-28	IRF240	5.4-13
H11A550	5.8-6	H4C018	1.1-4	IRF250	5.4-13
H11A550F	5.8-9	H4C027	6.2-28	IRF250A/NBP	6.4-30
H11A550S	5.8-9	H4C027	1.1-4	IRF330A/NBP	6.4-30
H11B1	5.8-7	H4C035	6.2-28	IRF350A/NBP	6.4-30

# Device Index

IRF450	5.4-13	LM101AH	6.4-26	LM2931AD-5.0	4.11-2
IRF450A/NBP	6.4-30	LM108AH	6.4-26	LM2931C	4.2-5
IRF510	5.4-9	LM11C	4.1-3	LM2931CD	4.11-2
IRF520	5.4-9	LM11CL	4.1-3	LM2931D-5.0	4.11-2
IRF530	5.4-9	LM11H	6.4-26	LM2931	4.9-2
IRF540	5.4-9	LM111	4.1-9	LM2931C	4.9-2
IRF610	5.4-8	LM117AH	6.4-26	LM2935	4.2-2, 4.9-2
IRF620	5.4-8	LM117K	6.4-26	LM301A	4.1-2
IRF630	5.4-8	LM124	4.1-6	LM301AD	4.11-2
IRF640	5.4-9	LM124AJ	6.4-26	LM307	4.1-3
IRF720	5.4-8	LM124J	6.4-26	LM308A	4.1-2
IRF730	5.4-8	LM137H	6.4-26	LM311	4.1-9
IRF740	5.4-8	LM137K	6.4-26	LM311D	4.11-2
IRF820	5.4-8	LM139	4.1-10	LM317	4.2-5
IRF830	5.4-8	LM139A	4.1-10	LM317L	4.2-5
IRF840	5.4-8	LM139AJ	6.4-26	LM317LD	4.11-2
J110	5.1-21	LM139J	6.4-26	LM317M	4.2-5
J111	5.1-21	LM158	4.1-5	LM317MDT	4.11-2
J112	5.1-21	LM201A	4.1-2	LM323	4.2-3
J113	5.1-21	LM201AD	4.11-2	LM323A	4.2-3
J202	5.1-20	LM211	4.1-9	LM324	4.1-5
J203	5.1-20	LM211D	4.11-2	LM324AD	4.11-2
J300	5.1-20	LM224	4.1-6	LM324D	4.11-2
J308	5.1-20	LM224D	4.11-2	LM337	4.2-5
J309	5.1-20	LM239	4.1-10	LM337M	4.2-5
J310	5.1-20	LM239A	4.1-10	LM339	4.1-10
LF347	4.1-5	LM239AD	4.11-2	LM339A	4.1-10
LF347B	4.1-5	LM239D	4.11-2	LM339AD	4.11-2
LF351	4.1-2	LM248	4.1-6	LM339D	4.11-2
LF351D	4.11-2	LM258	4.1-4	LM340-12	4.2-4
LF353	4.1-3	LM258D	4.11-2	LM340-15	4.2-4
LF353D	4.11-2	LM285D-1.2	4.11-2	LM340-18	4.2-4
LF356	4.1-2	LM285D-2.5	4.11-2	LM340-24	4.2-5
LF356B	4.1-2	LM285Z-1.2	4.4-2	LM340-5	4.2-3
LF357	4.1-2	LM285Z-2.5	4.4-2	LM340-6	4.2-3
LF357B	4.1-2	LM2900	4.1-6	LM340-8	4.2-3
LF411C	4.1-2	LM2901	4.1-10	LM340A-12	4.2-4
LF411CD	4.11-2	LM2901D	4.11-2	LM340A-15	4.2-4
LF412C	4.1-4	LM2902	4.1-6	LM340A-5	4.2-3
LF412CD	4.11-2	LM2902D	4.11-2	LM348	4.1-5
LF441C	4.1-3	LM2903	4.1-9	LM348D	4.11-2
LF441CD	4.11-2	LM2903D	4.11-2	LM350	4.2-5
LF442C	4.1-4	LM2904	4.1-4	LM358	4.1-4
LF442CD	4.11-2	LM2904D	4.11-2	LM358D	4.11-2
LF444C	4.1-5	LM293D	4.11-2	LM385BZ-1.2	4.4-2
LF444CD	4.11-2	LM2931-5.0	4.2-2	LM385BZ-2.5	4.4-2
LM101A	4.1-2	LM2931A-5.0	4.2-2	LM385D-1.2	4.11-2



# Device Index

LM385D-2.5	4.11-2	MAC16N	5.7-14	MAC218A4	5.7-9
LM385Z-1.2	4.4-2	MAC210-10	5.7-12	MAC218A4FP	5.7-10
LM385Z-2.5	4.4-2	MAC210-10FP	5.7-12	MAC218A6	5.7-9
LM3900	4.1-5	MAC210-4	5.7-12	MAC218A6FP	5.7-10
LM3900D	4.11-2	MAC210-4FP	5.7-12	MAC218A8	5.7-9
LM393	4.1-9	MAC210-6	5.7-12	MAC218A8FP	5.7-10
LM393A	4.1-9	MAC210-6FP	5.7-12	MAC219-10	5.7-10
LM393D	4.11-2	MAC210-8	5.7-12	MAC219-4	5.7-10
LM833	4.1-4	MAC210-8FP	5.7-12	MAC219-6	5.7-10
LM833D	4.11-2	MAC210A10	5.7-12	MAC219-8	5.7-10
LP1001	5.10-15, 5.10-19	MAC210A10FP	5.7-12	MAC223-10	5.7-15
LP1001A	5.10-15, 5.10-19	MAC210A4	5.7-12	MAC223-10FP	5.7-15
LP1983	5.10-15	MAC210A4FP	5.7-12	MAC223-4	5.7-15
MAC08BT1	5.7-7	MAC210A6	5.7-12	MAC223-4FP	5.7-15
MAC08DT1	5.7-7	MAC210A6FP	5.7-12	MAC223-6	5.7-15
MAC08MT1	5.7-7	MAC210A8	5.7-12	MAC223-6FP	5.7-15
MAC137-500	5.7-10	MAC210A8FP	5.7-12	MAC223-8	5.7-15
MAC137-600	5.7-10	MAC212-10	5.7-13	MAC223-8FP	5.7-15
MAC137-800	5.7-10	MAC212-10FP	5.7-13	MAC223A10	5.7-15
MAC137G-500	5.7-10	MAC212-4	5.7-13	MAC223A10FP	5.7-15
MAC137G-600	5.7-10	MAC212-4FP	5.7-13	MAC223A4	5.7-15
MAC137G-800	5.7-10	MAC212-6	5.7-13	MAC223A4FP	5.7-15
MAC15-10	5.7-14	MAC212-6FP	5.7-13	MAC223A6	5.7-15
MAC15-10FP	5.7-14	MAC212-8	5.7-13	MAC223A6FP	5.7-15
MAC15-4	5.7-14	MAC212-8FP	5.7-13	MAC223A8	5.7-15
MAC15-4FP	5.7-14	MAC212A10	5.7-13	MAC223A8FP	5.7-15
MAC15-6	5.7-14	MAC212A10FP	5.7-13	MAC224-10	5.7-15
MAC15-6FP	5.7-14	MAC212A4	5.7-13	MAC224-4	5.7-15
MAC15-8	5.7-14	MAC212A4FP	5.7-13	MAC224-6	5.7-15
MAC15-8FP	5.7-14	MAC212A6	5.7-13	MAC224-8	5.7-15
MAC15A10	5.7-14	MAC212A6FP	5.7-13	MAC224A10	5.7-15
MAC15A10FP	5.7-14	MAC212A8	5.7-13	MAC224A4	5.7-15
MAC15A4	5.7-14	MAC212A8FP	5.7-13	MAC224A6	5.7-15
MAC15A4FP	5.7-14	MAC213-10	5.7-13	MAC224A8	5.7-15
MAC15A6	5.7-14	MAC213-4	5.7-13	MAC228-10	5.7-11
MAC15A6FP	5.7-14	MAC213-6	5.7-13	MAC228-10FP	5.7-11
MAC15A8	5.7-14	MAC213-8	5.7-13	MAC228-4	5.7-11
MAC15A8FP	5.7-14	MAC218-10	5.7-9	MAC228-4FP	5.7-11
MAC15D	5.7-14	MAC218-10FP	5.7-10	MAC228-6	5.7-11
MAC15M	5.7-14	MAC218-4	5.7-9	MAC228-6FP	5.7-11
MAC15N	5.7-14	MAC218-4FP	5.7-10	MAC228-8	5.7-11
MAC16-10	5.7-14	MAC218-6	5.7-9	MAC228-8FP	5.7-11
MAC16-4	5.7-14	MAC218-6FP	5.7-10	MAC228A10	5.7-11
MAC16-6	5.7-14	MAC218-8	5.7-9	MAC228A10FP	5.7-11
MAC16-8	5.7-14	MAC218-8FP	5.7-10	MAC228A4	5.7-11
MAC16D	5.7-14	MAC218A10	5.7-9	MAC228A4FP	5.7-11
MAC16M	5.7-14	MAC218A10FP	5.7-10	MAC228A6	5.7-11

8

# Device Index

MAC228A6FP	5.7-11	MAC320-10	5.7-14	MBD101	5.1-33
MAC228A8	5.7-11	MAC320-10FP	5.7-14	MBD301	5.1-33
MAC228A8FP	5.7-11	MAC320-4	5.7-14	MBD701	5.1-33
MAC229-10	5.7-11	MAC320-4FP	5.7-14	MBRB1545CT	5.6-5
MAC229-10FP	5.7-11	MAC320-6	5.7-14	MBRB20100CT	5.6-5
MAC229-4	5.7-11	MAC320-6FP	5.7-14	MBRB20200CT	5.6-5
MAC229-4FP	5.7-11	MAC320-8	5.7-14	MBRB2060CT	5.6-5
MAC229-6	5.7-11	MAC320-8FP	5.7-14	MBRB2515L	5.6-3, 5.6-5
MAC229-6FP	5.7-11	MAC320A10	5.7-14	MBRB2535CTL	5.6-3, 5.6-5
MAC229-8	5.7-11	MAC320A10FP	5.7-14	MBRB2545CT	5.6-5
MAC229-8FP	5.7-11	MAC320A4	5.7-14	MBRB3030CT	5.6-5
MAC229A10	5.7-11	MAC320A4FP	5.7-14	MBRB3030CTL	5.6-3, 5.6-5
MAC229A10FP	5.7-11	MAC320A6	5.7-14	MBRB4030	5.6-5
MAC229A4	5.7-11	MAC320A6FP	5.7-14	MBRD1035CTL	5.6-5
MAC229A4FP	5.7-11	MAC320A8	5.7-14	MBRD340	5.6-5
MAC229A6	5.7-11	MAC320A8FP	5.7-14	MBRD360	5.6-5
MAC229A6FP	5.7-11	MAC321-10	5.7-15	MBRD640CT	5.6-5
MAC229A8	5.7-11	MAC321-4	5.7-15	MBRD660CT	5.6-5
MAC229A8FP	5.7-11	MAC321-6	5.7-15	MBRD835L	5.6-5
MAC3010-4	5.7-16	MAC321-8	5.7-15	MBRF1045	5.6-7
MAC3010-8	5.7-16	MAC625-4	5.7-15	MBRF1545CT	5.6-7
MAC3010-15	5.7-16	MAC625-6	5.7-15	MBRF20100CT	5.6-7
MAC3010-25	5.7-16	MAC625-8	5.7-15	MBRF20200CT	5.6-7
MAC3020-4	5.7-16	MAC635-4	5.7-15	MBRF2045CT	5.6-7
MAC3020-8	5.7-16	MAC635-6	5.7-15	MBRF2060CT	5.6-7
MAC3020-15	5.7-16	MAC635-8	5.7-15	MBRF2545CT	5.6-7
MAC3020-25	5.7-16	MAC8D	5.7-10	MBRF745	5.6-7
MAC3030-4	5.7-16	MAC8M	5.7-10	MBRP20030CTL	5.6-3, 5.6-10
MAC3030-8	5.7-16	MAC8N	5.7-10	MBRP20045CT	5.6-10
MAC3030-15	5.7-16	MAC9D	5.7-12	MBRP20060CT	5.6-10
MAC3030-25	5.7-16	MAC9M	5.7-12	MBRP30045CT	5.6-10
MAC3040-4	5.7-16	MAC9N	5.7-12	MBRP30060CT	5.6-10
MAC3040-8	5.7-16	MAC97-4	5.7-7	MBRP60035CTL	5.6-3, 5.6-10
MAC3040-15	5.7-16	MAC97-6	5.7-7	MBRS1100T3	5.6-4
MAC3040-25	5.7-16	MAC97-8	5.7-7	MBRS130LT3	5.6-3, 5.6-4
MAC3060-4	5.7-16	MAC97A4	5.7-7	MBRS140T3	5.6-4
MAC3060-8	5.7-16	MAC97A6	5.7-7	MBRS340T3	5.6-4
MAC3060-15	5.7-16	MAC97A8	5.7-7	MBRS360T3	5.6-4
MAC3060-25	5.7-16	MAC97B4	5.7-7	MBR0520L	5.6-3, 5.6-4
MAC310-10	5.7-12	MAC97B6	5.7-7	MBR0530	5.6-4
MAC310-4	5.7-12	MAC97B8	5.7-7	MBR0540	5.6-4
MAC310-6	5.7-12	MAD1103P	5.1-38	MBR10100	5.6-7
MAC310-8	5.7-12	MAD1105P	5.1-38	MBR1045	5.6-7
MAC310A10	5.7-12	MAD1107P	5.1-38	MBR1060	5.6-7
MAC310A4	5.7-12	MAD1108P	5.1-38	MBR1100	5.6-6
MAC310A6	5.7-12	MAD1109P	5.1-38	MBR1545CT	5.6-7
MAC310A8	5.7-12	MAD130P	5.1-38	MBR160	5.6-6

# Device Index

MBR1645	5.6-7	MCA3200ETL	1.1-2	MCM32400D	2.7-5
MBR20100CT	5.6-7	MCA6200ETL	1.1-2	MCM32410	2.7-5
MBR20200CT	5.6-7	MCA750ETL	1.1-2	MCM32420D	2.7-5
MBR2030CTL	5.6-7	MCCF33093	4.9-2	MCM3264A	2.7-4
MBR2045CT	5.6-7	MCCF33094	4.9-2	MCM32800	2.7-5
MBR2060CT	5.6-7	MCCF33095	4.9-3	MCM33100	2.7-5
MBR240100V	5.6-10	MCCF33096	4.9-3	MCM36100	2.7-5
MBR25060V	5.6-10	MCCF3334	4.9-2	MCM36100R8	2.7-7
MBR2515L	5.6-3, 5.6-7	MCCF79076	4.9-2	MCM36104	2.7-5
MBR2535CTL	5.6-3, 5.6-7	MCCS142233	3.1-9, 3.1-23	MCM36200	2.7-5
MBR2545CT	5.6-7	MCCS142234	3.1-9, 3.1-23	MCM36200R8	2.7-7
MBR28045V	5.6-10	MCCS142235	3.1-9, 3.1-23	MCM36204	2.7-5
MBR30100	5.6-8	MCH12140	3.1-25	MCM36400	2.7-5
MBR3045CT	5.6-9	MCH12140	3.1-10	MCM36404	2.7-5
MBR3045PT	5.6-8	MCK12140	3.1-10, 3.1-25	MCM36800	2.7-5
MBR3045ST	5.6-7	MCM101524	2.7-3	MCM36804	2.7-5
MBR3045WT	5.6-8	MCM101525	2.7-3	MCM4L4100B	2.7-6
MBR3100	5.6-6	MCM16100R8	2.7-7	MCM4L4400B	2.7-6
MBR340	5.6-6	MCM16200R8	2.7-7	MCM40100	2.7-5
MBR3545	5.6-9	MCM18100	2.7-5	MCM40200	2.7-5
MBR360	5.6-6	MCM18100R8	2.7-7	MCM40400	2.7-5
MBR4015LWT	5.6-8	MCM18200	2.7-5	MCM40420	2.7-5
MBR4045PT	5.6-8	MCM18200R8	2.7-7	MCM40800	2.7-5
MBR4045WT	5.6-8	MCM18400	2.7-5	MCM44100B	2.7-6
MBR5025L	5.6-8	MCM18800	2.7-5	MCM44182	4.8-6
MBR6030L	5.6-3, 5.6-9	MCM2814	2.7-6	MCM44256 Series	2.7-4
MBR6045	5.6-9	MCM29010E6	2.7-7	MCM44400B	2.7-6
MBR6045PT	5.6-8	MCM29020	2.7-6	MCM4464 Series	2.7-4
MBR6045WT	5.6-8	MCM29020E6	2.7-7	MCM5L4100A	2.7-6
MBR6545	5.6-9	MCM29040	2.7-6	MCM5L4170B	2.7-6
MBR745	5.6-7	MCM29040E6	2.7-7	MCM5L4190B	2.7-6
MBR7545	5.6-9	MCM29080	2.7-6	MCM5L4260B	2.7-6
MBR8045	5.6-9	MCM29100E6	2.7-7	MCM5L4280B	2.7-6
MBS4991	5.7-17	MCM32AX128	2.7-4	MCM5L4400A	2.7-6
MBS4992	5.7-17	MCM32AX32	2.7-4	MCM5L4800A	2.7-6
MBS4993	5.7-17	MCM32AX64	2.7-4	MCM5V4170B	2.7-6
MCA10000ECL	1.1-2	MCM32A32	2.7-4	MCM5V4190B	2.7-6
MCA2200ECL	1.1-2	MCM32A64	2.7-4	MCM5V4260B	2.7-6
MCA230	5.8-7	MCM32100D	2.7-5	MCM5V4800A	2.7-6
MCA230F	5.8-10	MCM32100R8	2.7-7	MCM5L1000A	2.7-6
MCA230S	5.8-10	MCM32103D	2.7-5	MCM5L14256A	2.7-6
MCA231	5.8-7	MCM32128	2.7-4	MCM511000A	2.7-6
MCA231F	5.8-10	MCM32130	2.7-5	MCM514256A	2.7-6
MCA231S	5.8-10	MCM32200R8	2.7-7	MCM516100	2.7-6
MCA255	5.8-7	MCM32230	2.7-5	MCM516100BJ	2.7-6
MCA255F	5.8-10	MCM32257	2.7-4	MCM516100BT	2.7-6
MCA255S	5.8-10	MCM32400	2.7-5	MCM516160AJ	2.7-6

# Device Index

MCM516160AT	2.7-6	MCM62980	2.7-2	MCM84000	2.7-5
MCM516180AJ	2.7-6	MCM62981	2.7-2	MCM84030	2.7-5
MCM516180AT	2.7-6	MCM62990A	2.7-2	MCM91000	2.7-5
MCM516400	2.7-6	MCM62995A	2.7-2	MCM91430	2.7-5
MCM516400B	2.7-6	MCM62996	2.7-3	MCM91600	2.7-5
MCM517400	2.7-6	MCM6306D	2.7-3	MCM94000	2.7-5
MCM517400B	2.7-6	MCM64AA32	2.7-4	MCM94030	2.7-5
MCM518160AJ	2.7-6	MCM64AB32	2.7-4	MCR08BT1	5.7-2
MCM518160AT	2.7-6	MCM64100	2.7-5	MCR08DT1	5.7-2
MCM518180AJ	2.7-6	MCM64400	2.7-5	MCR08MT1	5.7-2
MCM518180AT	2.7-6	MCM67A518	2.7-2	MCR100-3	5.7-2
MCM54100A	2.7-6	MCM67A618	2.7-2	MCR100-4	5.7-2
MCM54100A-C	2.7-6	MCM67B518	2.7-2	MCR100-6	5.7-2
MCM54170B	2.7-6	MCM67B618	2.7-2	MCR100-8	5.7-2
MCM54190B	2.7-6	MCM67C518	2.7-2	MCR102	5.7-2
MCM54260B	2.7-6	MCM67C618	2.7-2	MCR103	5.7-2
MCM54280B	2.7-6	MCM67D709	2.7-2	MCR106-2	5.7-3
MCM54400A	2.7-6	MCM67H518	2.7-2	MCR106-3	5.7-3
MCM54400A-C	2.7-6	MCM67H618	2.7-2	MCR106-4	5.7-3
MCM54400A-V	2.7-6	MCM67J518	2.7-2	MCR106-6	5.7-3
MCM54800A	2.7-6	MCM67J618	2.7-2	MCR106-8	5.7-3
MCM56824A	2.7-2	MCM67M518	2.7-2	MCR218-10	5.7-4
MCM62X308	2.7-2	MCM67M618	2.7-2	MCR218-10FP	5.7-4
MCM62Y308	2.7-2	MCM67Q709	2.7-2	MCR218-2	5.7-4
MCM6205D	2.7-3	MCM67Q804	2.7-2	MCR218-2FP	5.7-4
MCM6206D	2.7-3	MCM67T316	2.7-2	MCR218-3	5.7-4
MCM6208C	2.7-3	MCM6705A	2.7-3	MCR218-4	5.7-4
MCM6209C	2.7-3	MCM6706A	2.7-3	MCR218-4FP	5.7-4
MCM62110	2.7-2	MCM6706R	2.7-3	MCR218-6	5.7-4
MCM62110	2.3-3	MCM6708A	2.7-3	MCR218-6FP	5.7-4
MCM6226A	2.7-3	MCM6709A	2.7-3	MCR218-8	5.7-4
MCM6226B	2.7-3	MCM6709R	2.7-3	MCR218-8FP	5.7-4
MCM6227A	2.7-3	MCM6726	2.7-3	MCR22-2	5.7-2
MCM6227B	2.7-3	MCM6726A	2.7-3	MCR22-3	5.7-2
MCM6229A	2.7-3	MCM6728	2.7-3	MCR22-4	5.7-2
MCM6229B	2.7-3	MCM6728A	2.7-3	MCR22-6	5.7-2
MCM6246	2.7-3	MCM6729	2.7-3	MCR22-8	5.7-2
MCM62486A	2.7-2	MCM6729A	2.7-3	MCR225-10FP	5.7-6
MCM62486B	2.7-2	MCM72BA32	2.7-4	MCR225-2FP	5.7-6
MCM6249	2.7-3	MCM72BA64	2.7-4	MCR225-4FP	5.7-6
MCM6264C	2.7-3	MCM72BB32	2.7-4	MCR225-6FP	5.7-6
MCM6265C	2.7-3	MCM72BB64	2.7-4	MCR225-8FP	5.7-6
MCM62940A	2.7-2	MCM72MS32	2.7-4	MCR264-10	5.7-6
MCM62940B	2.7-2	MCM72MS64	2.7-4	MCR264-4	5.7-6
MCM62973A	2.7-2	MCM81000	2.7-5	MCR264-6	5.7-6
MCM62974A	2.7-2	MCM81430	2.7-5	MCR264-8	5.7-6
MCM62975A	2.7-2	MCM81600	2.7-5	MCR265-10	5.7-6

# Device Index

MCR265-2	5.7-6	MCT273	5.8-6	MC10EL11	3.1-22, 3.1-40
MCR265-4	5.7-6	MCT273F	5.8-9	MC10EL12	3.1-40
MCR265-6	5.7-6	MCT273S	5.8-9	MC10EL16	3.1-40
MCR265-8	5.7-6	MCT274	5.8-6	MC10EL31	3.1-40
MCR310-10	5.7-4	MCT274F	5.8-9	MC10EL32	3.1-40
MCR310-2	5.7-4	MCT274S	5.8-9	MC10EL33	3.1-40
MCR310-3	5.7-4	MCT275	5.8-6	MC10EL35	3.1-40
MCR310-4	5.7-4	MCT275F	5.8-9	MC10EL51	3.1-40
MCR310-6	5.7-4	MCT275S	5.8-9	MC10EL52	3.1-40
MCR310-8	5.7-4	MCT7805B	4.2-3	MC10EL58	3.1-40
MCR506-2	5.7-3	MCT7805C	4.2-3	MC10EL89	3.1-40
MCR506-3	5.7-3	MCT7806B	4.2-3	MC10E016	3.1-39
MCR506-4	5.7-3	MCT7806C	4.2-3	MC10E101	3.1-39
MCR506-6	5.7-3	MCT7808B	4.2-3	MC10E104	3.1-39
MCR506-8	5.7-3	MCT7808C	4.2-3	MC10E107	3.1-39
MCR68-2	5.7-5	MCT7812B	4.2-4	MC10E111	3.1-22, 3.1-39
MCR68-3	5.7-5	MCT7812C	4.2-4	MC10E112	3.1-39
MCR68-6	5.7-5	MCT7815B	4.2-4	MC10E116	3.1-39
MCR69-2	5.7-6	MCT7815C	4.2-4	MC10E122	3.1-39
MCR69-3	5.7-6	MCT7824B	4.2-5	MC10E131	3.1-39
MCR69-6	5.7-6	MCT7824C	4.2-5	MC10E136	3.1-39
MCR703A	5.7-3	MC10/100ELT25	3.1-8	MC10E137	3.1-39
MCR703A1	5.7-3	MC10/100EL11	3.1-7	MC10E141	3.1-39
MCR704A	5.7-3	MC10/100E111	3.1-7	MC10E142	3.1-39
MCR704A1	5.7-3	MC10/100E195	3.1-8	MC10E143	3.1-39
MCR706A	5.7-3	MC10/100E196	3.1-8	MC10E150	3.1-39
MCR706A1	5.7-3	MC10/100E211	3.1-7	MC10E151	3.1-39
MCR708A	5.7-3	MC10/100H600	3.1-8	MC10E154	3.1-39
MCR708A1	5.7-3	MC10/100H601	3.1-8	MC10E155	3.1-39
MCR72-10	5.7-4	MC10/100H602	3.1-8	MC10E156	3.1-39
MCR72-2	5.7-4	MC10/100H603	3.1-8	MC10E157	3.1-39
MCR72-3	5.7-4	MC10/100H604	3.1-8	MC10E158	3.1-39
MCR72-4	5.7-4	MC10/100H605	3.1-8	MC10E160	3.1-39
MCR72-6	5.7-4	MC10/100H606	3.1-8	MC10E163	3.1-39
MCR72-8	5.7-4	MC10/100H607	3.1-8	MC10E164	3.1-39
MCT2	5.8-6	MC10/100H640	3.1-7	MC10E1651	3.1-40
MCT2E	5.8-6	MC10/100H641	3.1-8	MC10E1652	3.1-40
MCT2EF	5.8-9	MC10/100H642	3.1-7	MC10E166	3.1-39
MCT2ES	5.8-9	MC10/100H643	3.1-7	MC10E167	3.1-39
MCT2F	5.8-9	MC10/100H644	3.1-7	MC10E171	3.1-39
MCT2S	5.8-9	MC10/100H646	3.1-7	MC10E175	3.1-39
MCT271	5.8-6	MC10/100H660	3.1-9	MC10E193	3.1-39
MCT271F	5.8-9	MC10ELT25	3.1-23, 3.1-40	MC10E195	3.1-23, 3.1-39
MCT271S	5.8-9	MC10EL01	3.1-40	MC10E196	3.1-23, 3.1-39
MCT272	5.8-6	MC10EL04	3.1-40	MC10E197	3.1-39
MCT272F	5.8-9	MC10EL05	3.1-40	MC10E211	3.1-22, 3.1-39
MCT272S	5.8-9	MC10EL07	3.1-40	MC10E212	3.1-39

# Device Index

MC10E241	3.1-39	MC10H166	3.1-37	MC100ELT25	3.1-23, 3.1-40
MC10E256	3.1-39	MC10H171	3.1-37	MC100EL01	3.1-40
MC10E336	3.1-39	MC10H172	3.1-37	MC100EL04	3.1-40
MC10E337	3.1-40	MC10H173	3.1-37	MC100EL05	3.1-40
MC10E404	3.1-40	MC10H174	3.1-37	MC100EL07	3.1-40
MC10E416	3.1-40	MC10H175	3.1-37	MC100EL11	3.1-22, 3.1-40
MC10E431	3.1-40	MC10H176	3.1-37	MC100EL12	3.1-40
MC10E445	3.1-40	MC10H179	3.1-38	MC100EL16	3.1-40
MC10E446	3.1-40	MC10H180	3.1-38	MC100EL31	3.1-40
MC10E451	3.1-40	MC10H181	3.1-38	MC100EL32	3.1-40
MC10E452	3.1-40	MC10H186	3.1-38	MC100EL33	3.1-40
MC10E457	3.1-40	MC10H188	3.1-38	MC100EL35	3.1-40
MC10H016	3.1-37	MC10H189	3.1-38	MC100EL51	3.1-40
MC10H100	3.1-37	MC10H209	3.1-38	MC100EL52	3.1-40
MC10H101	3.1-37	MC10H210	3.1-38	MC100EL58	3.1-40
MC10H102	3.1-37	MC10H211	3.1-38	MC100E016	3.1-39
MC10H103	3.1-37	MC10H330	3.1-38	MC100E101	3.1-39
MC10H104	3.1-37	MC10H332	3.1-38	MC100E104	3.1-39
MC10H105	3.1-37	MC10H334	3.1-38	MC100E107	3.1-39
MC10H106	3.1-37	MC10H350	3.1-8, 3.1-23	MC100E111	3.1-22, 3.1-39
MC10H107	3.1-37		3.1-38	MC100E112	3.1-39
MC10H109	3.1-37	MC10H351	3.1-8, 3.1-23	MC100E116	3.1-39
MC10H113	3.1-37		3.1-38	MC100E122	3.1-39
MC10H115	3.1-37	MC10H352	3.1-8, 3.1-23	MC100E131	3.1-39
MC10H116	3.1-37		3.1-38	MC100E136	3.1-39
MC10H117	3.1-37	MC10H423	3.1-38	MC100E137	3.1-39
MC10H118	3.1-37	MC10H424	3.1-8, 3.1-23	MC100E141	3.1-39
MC10H119	3.1-37		3.1-38	MC100E142	3.1-39
MC10H121	3.1-37	MC10H600	3.1-23, 3.1-38	MC100E143	3.1-39
MC10H123	3.1-37	MC10H601	3.1-23, 3.1-38	MC100E150	3.1-39
MC10H124	3.1-8, 3.1-23	MC10H602	3.1-23, 3.1-38	MC100E151	3.1-39
	3.1-37	MC10H603	3.1-23, 3.1-38	MC100E154	3.1-39
MC10H125	3.1-8, 3.1-23	MC10H604	3.1-23, 3.1-38	MC100E155	3.1-39
	3.1-37	MC10H605	3.1-23, 3.1-38	MC100E156	3.1-39
MC10H130	3.1-37	MC10H606	3.1-23, 3.1-38	MC100E157	3.1-39
MC10H131	3.1-37	MC10H607	3.1-23, 3.1-38	MC100E158	3.1-39
MC10H135	3.1-37	MC10H640	3.1-22, 3.1-38	MC100E160	3.1-39
MC10H136	3.1-37	MC10H641	3.1-22, 3.1-38	MC100E163	3.1-39
MC10H141	3.1-37	MC10H642	3.1-22, 3.1-38	MC100E164	3.1-39
MC10H145	3.1-37	MC10H643	3.1-22, 3.1-38	MC100E166	3.1-39
MC10H158	3.1-37	MC10H644	3.1-22, 3.1-38	MC100E167	3.1-39
MC10H159	3.1-37	MC10H645	3.1-7, 3.1-22	MC100E171	3.1-39
MC10H160	3.1-37		3.1-38	MC100E175	3.1-39
MC10H161	3.1-37	MC10H646	3.1-22, 3.1-38	MC100E193	3.1-39
MC10H162	3.1-37	MC10H660	3.1-23, 3.1-38	MC100E195	3.1-23, 3.1-39
MC10H164	3.1-37	MC10H680	3.1-38	MC100E196	3.1-23, 3.1-39
MC10H165	3.1-37	MC10H681	3.1-38	MC100E211	3.1-22, 3.1-39

# Device Index

MC100E212	3.1-39	MC10119	3.1-35	MC10192	3.1-36
MC100E241	3.1-39	MC10121	3.1-35	MC10193	3.1-36
MC100E256	3.1-39	MC10123	3.1-35	MC10195	3.1-36
MC100E336	3.1-39	MC10124	3.1-8, 3.1-23	MC10197	3.1-36
MC100E337	3.1-40		3.1-35	MC10198	3.1-36
MC100E404	3.1-40	MC10125	3.1-8, 3.1-23	MC10210	3.1-36
MC100E416	3.1-40		3.1-35	MC10211	3.1-36
MC100E431	3.1-40	MC10128	3.1-35	MC10212	3.1-36
MC100E445	3.1-40	MC10129	3.1-35	MC10216	3.1-36
MC100E446	3.1-40	MC10130	3.1-35	MC10231	3.1-36
MC100E451	3.1-40	MC10131	3.1-35	MC10319	4.5-2, 4.8-4
MC100E452	3.1-40	MC10132	3.1-35	MC10319DW	4.11-3
MC100E457	3.1-40	MC10133	3.1-35	MC10320	4.5-3
MC100H600	3.1-23, 3.1-38	MC10134	3.1-35	MC10320-1	4.5-3
MC100H601	3.1-23, 3.1-38	MC10135	3.1-35	MC10321	4.5-2, 4.8-4
MC100H602	3.1-23, 3.1-38	MC10136	3.1-35	MC10321DW	4.11-3
MC100H603	3.1-23, 3.1-38	MC10137	3.1-35	MC10322	4.5-3, 4.8-4
MC100H604	3.1-23, 3.1-38	MC10138	3.1-35	MC10324	4.5-3, 4.8-4
MC100H605	3.1-23, 3.1-38	MC10141	3.1-35	MC10804	3.1-36
MC100H606	3.1-23, 3.1-38	MC10153	3.1-35	MC10805	3.1-36
MC100H607	3.1-23, 3.1-38	MC10154	3.1-35	MC12000	4.7-31
MC100H640	3.1-22, 3.1-38	MC10158	3.1-35	MC12002	4.7-31
MC100H641	3.1-22, 3.1-38	MC10159	3.1-35	MC12002	3.1-10, 3.1-24
MC100H642	3.1-22, 3.1-38	MC10160	3.1-35	MC12009	4.7-31
MC100H643	3.1-22, 3.1-38	MC10161	3.1-35	MC12009	3.1-10, 3.1-24
MC100H644	3.1-22, 3.1-38	MC10162	3.1-36	MC12011	4.7-31
MC100H646	3.1-22, 3.1-38	MC10164	3.1-36	MC12011	3.1-10, 3.1-24
MC100H660	3.1-23, 3.1-38	MC10165	3.1-36	MC12013	4.7-31
MC100H680	3.1-38	MC10166	3.1-36	MC12013	3.1-10, 3.1-24
MC100H681	3.1-38	MC10168	3.1-36	MC12014	4.7-31
MC10100	3.1-35	MC10170	3.1-36	MC12014	3.1-10, 3.1-24
MC10101	3.1-35	MC10171	3.1-36	MC12015	4.7-31
MC10102	3.1-35	MC10172	3.1-36	MC12015	3.1-10, 3.1-24
MC10103	3.1-35	MC10173	3.1-36	MC12016	4.7-31
MC10104	3.1-35	MC10174	3.1-36	MC12016	3.1-10, 3.1-24
MC10105	3.1-35	MC10175	3.1-36	MC12017	4.7-31
MC10106	3.1-35	MC10176	3.1-36	MC12017	3.1-10, 3.1-24
MC10107	3.1-35	MC10177	3.1-23	MC12018	4.7-31
MC10109	3.1-35	MC10177	3.1-8	MC12018	3.1-10, 3.1-24
MC10110	3.1-35	MC10178	3.1-36	MC12019	4.7-31
MC10111	3.1-35	MC10181	3.1-36	MC12019	3.1-10, 3.1-24
MC10113	3.1-35	MC10186	3.1-36	MC12022A	4.7-31
MC10114	3.1-35	MC10188	3.1-36	MC12022A	3.1-9, 3.1-24
MC10115	3.1-35	MC10189	3.1-36	MC12022B	4.7-31
MC10116	3.1-35	MC10190	3.1-8, 3.1-23	MC12022B	3.1-9, 3.1-24
MC10117	3.1-35		3.1-36	MC12022LVA	3.1-9, 3.1-24
MC10118	3.1-35	MC10191	3.1-8	MC12022LVB	3.1-9, 3.1-24

# Device Index

MC12022SLA	3.1-9, 3.1-24	MC13022DW	4.11-3	MC14001B	3.1-43
MC12022SLB	3.1-9, 3.1-24	MC13024	4.8-2	MC14001UB	3.1-43
MC12022TSA	3.1-9, 3.1-24	MC13024DW	4.11-4	MC14002B	3.1-43
MC12022TSB	3.1-9, 3.1-24	MC13025	4.8-2	MC14002UB	3.1-43
MC12022TVA	3.1-9, 3.1-24	MC13028	4.8-2	MC14006B	3.1-43
MC12022TVB	3.1-9, 3.1-24	MC13055	4.7-2	MC14007UB	3.1-43
MC12023	4.7-31	MC13055D	4.11-4	MC14008B	3.1-43
MC12023	3.1-10, 3.1-24	MC13060	4.7-28, 4.8-2	MC14011B	3.1-43
MC12025	3.1-10, 3.1-24	MC13060D	4.11-4	MC14011UB	3.1-43
MC12026A	3.1-24	MC13077	4.8-3, 4.8-9	MC14012B	3.1-43
MC12026B	3.1-24	MC13077DW	4.8-9	MC14012UB	3.1-43
MC12028A	3.1-9, 3.1-24	MC13077P	4.8-9	MC14013B	3.1-43
MC12028B	3.1-9, 3.1-24	MC13081	4.8-4	MC14014B	3.1-43
MC12031A	3.1-10, 3.1-24	MC13135	4.7-2, 4.7-6	MC14015B	3.1-43
MC12031B	3.1-10, 3.1-24	MC13136	4.7-2	MC14016B	3.1-43
MC12032A	3.1-10, 3.1-25	MC13136DW	4.7-6	MC14017B	3.1-43
MC12032B	3.1-10, 3.1-25	MC13136P	4.7-6	MC14018B	3.1-43
MC12033A	3.1-9, 3.1-25	MC13155	4.7-2	MC14020B	3.1-43
MC12033B	3.1-10, 3.1-25	MC13155D	4.7-4	MC14021B	3.1-43
MC12034A	3.1-9, 3.1-25	MC13156	4.7-2, 4.7-5	MC14022B	3.1-43
MC12034B	3.1-9, 3.1-25	MC13156DW	4.7-5	MC14023B	3.1-43
MC12036A	3.1-9, 3.1-25	MC13175	4.7-3, 4.7-6	MC14023UB	3.1-43
MC12036B	3.1-9, 3.1-25	MC13176	4.7-3, 4.7-6	MC14024B	3.1-43
MC12040	4.7-31	MC13176D	4.7-6	MC14025B	3.1-43
MC12040	3.1-10, 3.1-25	MC1330A	4.8-4	MC14025UB	3.1-43
MC12061	4.7-31	MC1350	4.1-7, 4.8-4	MC14027B	3.1-43
MC12061	3.1-10, 3.1-25	MC1350D	4.1-7, 4.11-2	MC14028B	3.1-43
MC12073	4.7-31	MC1357	4.8-5	MC14029B	3.1-43
MC12073	3.1-9, 3.1-25	MC1357D	4.11-2	MC1403	4.4-2
MC12074	4.7-31	MC1373	4.8-4	MC1403A	4.4-2
MC12074	3.1-9, 3.1-25	MC1374	4.8-4	MC1403D	4.11-2
MC12076	3.1-9, 3.1-25	MC1377	4.8-3	MC14035B	3.1-43
MC12078	3.1-9, 3.1-25	MC1377DW	4.11-2	MC14038B	3.1-43
MC12079	3.1-25	MC1378	4.8-5, 4.8-8	MC1404AU10	4.4-2
MC12080	3.1-25	MC1378FN	4.8-8, 4.11-2	MC1404AU5	4.4-2
MC12083	3.1-9, 3.1-25	MC1378P	4.8-8	MC1404AU6	4.4-2
MC12089	3.1-10, 3.1-25	MC1382DW	4.11-2	MC1404U10	4.4-2
MC12090	4.7-31	MC1388	4.8-3	MC1404U5	4.4-2
MC12090	3.1-10, 3.1-25	MC1391	4.8-3	MC1404U6	4.4-2
MC12100	3.1-10, 3.1-25	MC14C88B	4.6-5, 4.6-6	MC14040B	3.1-43
MC12101	3.1-10, 3.1-25	MC14C88BD	4.11-2	MC14042B	3.1-43
MC12148	3.1-10, 3.1-25	MC14C89ABD	4.11-3	MC14043B	3.1-43
MC13001X	4.8-4	MC14C89B	4.6-6	MC14044B	3.1-43
MC13007X	4.8-4	MC14C89BD	4.11-3	MC14046B	3.1-43
MC13017	4.8-3	MC14LC5472	4.7-12, 4.7-13	MC14046B	3.1-10
MC13020	4.8-2	MC14LC5494EVK	4.7-13	MC14049B	3.1-43
MC13022	4.8-2	MC14000UB	3.1-43	MC14049UB	3.1-43



# Device Index

MC14050B	3.1-43	MC142103	4.11-7	MC145000FN	4.11-6
MC14051B	3.1-43	MC143120	2.6-2	MC145001	4.6-8
MC14052B	3.1-44	MC143150	2.6-3	MC145001FN	4.11-6
MC14053B	3.1-44	MC143403	4.1-6	MC14501UB	3.1-44
MC14060B	3.1-44	MC143403D	4.11-7	MC145010	4.10-3
MC14066B	3.1-44	MC143404	4.1-6	MC145010DW	4.11-7
MC14067B	3.1-44	MC1436	4.1-3	MC145011	4.10-3
MC14068B	3.1-44	MC1436CD	4.11-2	MC145011DW	4.11-7
MC14069UB	3.1-44	MC1436D	4.11-2	MC14502B	3.1-44
MC14070B	3.1-44	MC14410DW	4.11-7	MC145026	4.8-25
MC14071B	3.1-44	MC144105	4.8-6	MC145026D	4.11-7
MC14072B	3.1-44	MC14411	4.7-25	MC145027	4.8-25
MC14073B	3.1-44	MC14411DW	4.11-7	MC145027DW	4.11-7
MC14075B	3.1-44	MC144110	4.5-3	MC145028	4.8-25
MC14076B	3.1-44	MC144110DW	4.11-6	MC145028DW	4.11-7
MC14077B	3.1-44	MC144111	4.5-3	MC14503B	3.1-44
MC14078B	3.1-44	MC144111DW	4.11-6	MC145030	4.8-25
MC1408	4.5-3	MC144143	4.8-5, 4.8-21	MC145030DW	4.11-7
MC14081B	3.1-44	MC144143P	4.8-21	MC145033	4.8-25
MC14082B	3.1-44	MC14415	3.1-44	MC145033DW	4.11-7
MC14093B	3.1-44	MC14433	4.5-2	MC145034	4.8-25
MC14094B	3.1-44	MC14433DW	4.11-6	MC145034DW	4.11-7
MC14099B	3.1-44	MC14442	4.5-2	MC145035	4.8-25
MC14106B	3.1-44	MC14442FN	4.11-6	MC145035DW	4.11-7
MC1411	4.6-7	MC14443	4.5-2	MC14504B	3.1-8, 3.1-23
MC1411B	4.6-7	MC14443DW	4.11-6		3.1-44
MC1412	4.6-7	MC14447	4.5-2	MC145040	4.5-2
MC1412B	4.6-7	MC14447DW	4.11-6	MC145040FN1	4.11-6
MC1413	4.6-7	MC1445	4.1-7	MC145040FN2	4.11-6
MC1413B	4.6-7	MC14467	4.11-7	MC145041	4.5-2
MC1413D	4.11-2	MC14467-1	4.10-3	MC145041FN1	4.11-6
MC1416	4.6-7	MC14468	4.10-3, 4.11-7	MC145041FN2	4.11-6
MC1416B	4.6-7	MC14469	4.8-25	MC145050	4.5-2
MC14161B	3.1-44	MC14469FN	4.11-7	MC145050DW	4.11-6
MC141620	4.8-4	MC14470	4.10-3	MC145051	4.5-2
MC141621	4.8-3, 4.8-4	MC14489	4.6-8	MC145051DW	4.11-6
	4.8-22	MC14489DW	4.11-6	MC145053	4.5-2
MC141621FU	4.8-22	MC14490	3.1-9, 3.1-24	MC145053D	4.11-6
MC141625	4.8-3, 4.8-4		3.1-44	MC14506UB	3.1-44
	4.8-23	MC14495	4.6-8	MC14508B	3.1-44
MC141625FU	4.8-23	MC14495DW1	4.11-6	MC14510B	3.1-44
MC14163B	3.1-44	MC14497	4.8-25, 4.11-7	MC145100	4.7-11
MC14174B	3.1-44	MC14499	4.6-8	MC145106	4.7-30
MC14175B	3.1-44	MC14499DW	4.11-6	MC145106FN	4.11-6
MC14194B	3.1-44	MC14500B	3.1-9, 3.1-24	MC14511B	4.6-8
MC142100	4.7-11		3.1-44	MC14511B	3.1-44
MC142100DW	4.11-7	MC145000	4.6-8	MC14512B	3.1-44

# Device Index

MC14513B	4.6-8	MC14519B	3.1-45	MC145428	4.7-15
MC14513B	3.1-44	MC145191	4.7-30	MC145428DW	4.11-7
MC14514B	3.1-44	MC145192	4.7-30	MC145429	4.7-16
MC145145-2	4.7-30	MC14520B	3.1-45	MC14543B	4.6-9
MC145145DW1	4.11-6	MC14521B	3.1-45	MC14543B	3.1-45
MC145146-2	4.7-30	MC14522B	3.1-45	MC145432	4.7-10
MC145146DW1	4.11-6	MC14526B	3.1-45	MC145436	4.7-11
MC145149	4.7-30	MC14527B	3.1-45	MC145436DW	4.11-7
MC145149DW	4.11-6	MC14528B	3.1-45	MC145439	4.11-7
MC14515B	3.1-45	MC14529B	3.1-45	MC14544B	4.6-9
MC145151-2	4.7-30	MC14530B	3.1-45	MC14544B	3.1-45
MC145151DW2	4.11-6	MC14531B	3.1-45	MC145442	4.7-25
MC145151FN2	4.11-6	MC14532B	3.1-45	MC145442DW	4.11-7
MC145152-2	4.7-30	MC14534B	3.1-45	MC145443	4.7-25
MC145152DW2	4.11-6	MC14536B	3.1-45	MC145443DW	4.11-7
MC145152FN2	4.11-6	MC14538B	3.1-45	MC145444	4.7-25
MC145155-2	4.7-30	MC14539B	3.1-45	MC145447DW	4.11-7
MC145155DW2	4.11-6	MC145402	4.5-3	MC145453	4.6-9
MC145155FN2	4.11-6	MC145403	4.6-7	MC145453FN	4.11-6
MC145156-2	4.7-30	MC145403DW	4.11-7	MC145460EVK	4.7-26
MC145156DW2	4.11-6	MC145404	4.6-7	MC14547B	4.6-8
MC145156FN2	4.11-6	MC145404DW	4.11-7	MC14547B	3.1-45
MC145157-2	4.7-30	MC145405	4.6-7	MC145472	4.7-12
MC145157DW2	4.11-6	MC145405DW	4.11-7	MC145472FE	4.11-7
MC145157FN2	4.11-6	MC145406	4.6-7, 4.7-11	MC145472FU	4.11-7
MC145158-2	4.7-30	MC145406DW	4.11-7	MC145474	4.7-11, 4.7-12
MC145158DW2	4.11-6	MC145407	4.6-7, 4.7-11		4.7-13
MC145158FN2	4.11-6	MC145407DW	4.11-7	MC145475	4.7-11, 4.7-12
MC145159-1	4.7-30	MC145408	4.6-7		4.7-13
MC145159DW1	4.11-6	MC145408DW	4.11-7	MC145475DW	4.11-7
MC145159FN	4.11-6	MC14541B	3.1-45	MC145480	4.7-11, 4.7-25
MC14516B	3.1-45	MC145411	4.7-25	MC145480DW	4.11-7
MC145160	4.7-30	MC145412	4.7-16, 4.11-7	MC145488	4.7-11, 4.7-13
MC145160DW	4.11-6	MC145413	4.7-16		4.11-7
MC145161	4.7-30	MC145414	4.7-10	MC14549B	4.5-2
MC145161DW	4.11-6	MC145416	4.7-16	MC14549B	3.1-45
MC145166	4.7-30	MC145416DW	4.11-7	MC1455BP1	4.10-2
MC145166DW	4.11-6	MC145421	4.7-9, 4.7-15	MC1455D	4.11-2
MC145167	4.7-30	MC145421DW	4.11-7	MC1455D1	4.10-2
MC145167DW	4.11-6	MC145422	4.7-9, 4.7-14	MC1455P1	4.10-2
MC145168	4.7-30		4.7-15	MC1455U1	4.10-2
MC145168DW	4.11-6	MC145422DW	4.11-7	MC145500	4.7-8, 4.7-11
MC145169	4.7-30	MC145425	4.7-9, 4.7-15	MC145500 Series	4.7-8
MC14517B	3.1-45	MC145425DW	4.11-7	MC145501	4.7-8
MC145170	4.7-30	MC145426	4.7-9, 4.7-14	MC145502	4.7-8, 4.11-7
MC145170D	4.11-6		4.7-15	MC145503	4.7-8
MC14518B	3.1-45	MC145426DW	4.11-7	MC145503DW	4.11-7

# Device Index

MC145505	4.7-8	MC14576A	4.8-24	MC1596	4.7-3, 4.7-31
MC145505DW	4.11-7	MC14576B	4.8-5, 4.8-24	MC16LX543	3.1-7, 3.1-22
MC14551B	3.1-45	MC14576BF	4.11-6	MC16LX646	3.1-7, 3.1-22
MC145512	4.7-16	MC14577A	4.8-24	MC16LX952	3.1-7, 3.1-22
MC145513	4.7-16	MC14577B	4.1-8, 4.8-24	MC1648	4.7-31
MC14553B	3.1-45	MC14577BF	4.8-24, 4.11-6	MC1648	3.1-54
MC145532	4.7-9, 4.7-11	MC14577P	4.8-24	MC1650	3.1-54
	4.7-25	MC14578	4.1-9, 4.10-3	MC1651	3.1-54
MC145532DW	4.11-7	MC14578D	4.11-6	MC1658	4.7-31
MC145536	4.7-25	MC1458	4.1-4	MC1658	3.1-54
MC145537EVK	4.7-10	MC1458C	4.1-4	MC1660	3.1-54
MC145540	4.7-9, 4.7-10	MC1458CD	4.11-2	MC1662	3.1-54
MC145540DW	4.11-7	MC1458D	4.11-2	MC1670	3.1-54
MC14555B	3.1-45	MC14583B	3.1-45	MC1672	3.1-54
MC145554	4.7-8	MC14584B	3.1-45	MC1690	4.7-31
MC145554DW	4.11-7	MC14585B	3.1-46	MC1692	3.1-54
MC145557	4.7-8	MC14598B	3.1-46	MC1723	4.2-5
MC145557DW	4.11-7	MC14599B	3.1-46	MC1723CD	4.11-3
MC14556B	3.1-45	MC14618	2.5-28	MC1741	4.1-3
MC145564	4.7-8	MC146805E2	2.5-28	MC1741C	4.1-3
MC145564DW	4.11-7	MC146818A	2.5-28	MC1741CD	4.11-3
MC145567	4.7-8	MC146823	2.5-28	MC1747	4.1-5
MC145567DW	4.11-7	MC1472	4.6-7	MC1747C	4.1-4
MC14557B	3.1-45	MC1488	4.6-5, 4.6-6	MC1747CD	4.11-3
MC14558B	4.6-8, 4.6-9	MC1488D	4.11-2	MC1748C	4.1-2
MC14559B	4.5-2	MC1489	4.6-5, 4.6-6	MC1776	4.1-3
MC14559B	3.1-45	MC1489A	4.6-5, 4.6-6	MC1776C	4.1-3
MC14560B	3.1-45	MC1489D	4.11-3	MC1776CD	4.11-3
MC14561B	3.1-45	MC1490	4.1-7	MC18LX843	3.1-7, 3.1-22
MC145611	4.7-11	MC1494	4.10-2	MC20LX240	3.1-7, 3.1-22
MC14562B	3.1-45	MC1494L	4.10-2	MC20LX244	3.1-7, 3.1-22
MC14566B	3.1-45	MC1495D	4.11-3	MC20LX245	3.1-7, 3.1-22
MC14568B	3.1-10, 3.1-45	MC1495L	4.10-2	MC20LX373	3.1-7, 3.1-22
MC14569B	3.1-45	MC1496	4.7-3, 4.7-31	MC20LX374	3.1-7, 3.1-22
MC145705	4.6-7	MC1496D	4.11-3	MC26LS30	4.6-6
MC145705DW	4.11-7	MC1503	4.4-2	MC26LS31	4.6-6
MC145706	4.6-7	MC1503A	4.4-2	MC26LS31D	4.11-3
MC145706DW	4.11-7	MC1504U10	4.4-2	MC26LS32	4.6-6
MC145707	4.6-7	MC1504U5	4.4-2	MC26LS32D	4.11-3
MC145707DW	4.11-7	MC1504U6	4.4-2	MC26S10	4.6-5
MC14572UB	3.1-45	MC1508	4.5-3	MC26S10D	4.11-3
MC14573	4.1-8	MC1536	4.1-3	MC2681	2.2-14
MC14573D	4.11-6	MC1545	4.1-7	MC2831A	4.7-3
MC14574	4.1-10	MC1558	4.1-5	MC2831AD	4.11-3
MC14574D	4.11-6	MC1594	4.10-2	MC2833	4.7-3
MC14575	4.1-8, 4.1-9	MC1594L	4.10-2	MC3301	4.1-6
MC14575D	4.11-6	MC1595L	4.10-2	MC3302	4.1-10

# Device Index

MC33023	4.2-9	MC33076	4.1-4	MC33172D	4.11-4
MC33023DW	4.11-4	MC33076D	4.11-4	MC33174	4.1-6
MC33023FN	4.11-4	MC33077	4.1-4	MC33174D	4.11-4
MC33025	4.2-10	MC33077D	4.11-4	MC33178	4.1-4
MC33025DW	4.11-4	MC33078	4.1-4	MC33178D	4.11-4
MC33025FN	4.11-4	MC33078D	4.11-4	MC33179	4.1-6
MC3303	4.1-6	MC33079	4.1-6	MC33179D	4.11-4
MC3303D	4.11-3	MC33079D	4.11-4	MC33181	4.1-3
MC33030P	4.3-7	MC33091	4.9-3, 4.9-7	MC33182	4.1-4
MC33033	4.3-5, 4.3-8	MC33091D	4.9-7, 4.11-4	MC33184	4.1-6
MC33033DW	4.3-5, 4.11-4	MC33091P	4.9-7	MC33192	4.9-3
MC33033P	4.3-5	MC33092	4.9-2	MC33192DW	4.9-8
MC33034	4.3-5, 4.3-6 4.3-8	MC33092DW	4.9-8	MC33201	4.1-3
MC33035	4.3-4, 4.3-5 4.3-6, 4.3-8	MC33102	4.1-4	MC33202	4.1-5
MC33035DW	4.3-6, 4.11-4	MC33102D	4.11-4	MC33204	4.1-6
MC33035P	4.3-6	MC33110	4.7-28, 4.7-29	MC33218	4.7-21, 4.7-23 4.7-28, 4.7-29
MC33039D	4.11-4	MC33110D	4.11-4	MC33218DW	4.7-12, 4.11-4
MC33039D	4.3-8	MC33111	4.7-28, 4.7-29	MC33218P	4.7-21
MC33039P	4.3-8	MC33120	4.7-7, 4.7-9 4.7-11, 4.7-28	MC33261	4.2-12
MC33060A	4.2-7	MC33120FN	4.7-7, 4.11-4	MC33261D	4.2-12, 4.11-4
MC33060AD	4.11-4	MC331201P	4.7-7	MC33261P	4.2-12
MC33063A	4.2-9	MC33121	4.7-7, 4.7-28	MC33262	4.2-12, 4.2-13
MC33064	4.2-15	MC33121FN	4.11-4	MC33262D	4.2-13
MC33064D-5	4.2-15, 4.11-4	MC33122	4.7-8, 4.7-28	MC33262P	4.2-13
MC33064P-5	4.2-15	MC33129	4.2-7	MC33267	4.2-3, 4.2-6 4.9-2
MC33065	4.2-11	MC33129D	4.11-4	MC33269-ADJ	4.2-5
MC33065DW	4.11-4	MC33151D	4.2-17, 4.11-4	MC33269-12	4.2-3
MC33065DW-H	4.11-4	MC33151P	4.2-17	MC33269-3.3	4.2-2
MC33065DW-L	4.11-4	MC33152D	4.2-17, 4.11-4	MC33269-5	4.2-3
MC33066	4.2-10	MC33152P	4.2-17	MC33272	4.1-4
MC33066DW	4.11-4	MC33160	4.2-6	MC33272D	4.11-4
MC33067	4.2-10	MC33160P	4.2-16	MC33274	4.1-6
MC33067DW	4.11-4	MC33161D	4.2-16, 4.11-4	MC33274D	4.11-4
MC33071	4.1-3	MC33161P	4.2-16	MC33282	4.1-4
MC33071A	4.1-3	MC33163	4.2-9	MC33282D	4.11-4
MC33071AD	4.11-4	MC33164	4.2-15	MC33284	4.1-6
MC33071D	4.11-4	MC33164D-3	4.2-15, 4.11-4	MC33284D	4.11-4
MC33072	4.1-4	MC33164D-5	4.2-15, 4.11-4	MC33293	4.9-3
MC33072A	4.1-4	MC33164P-3	4.2-15	MC33293T	4.9-4
MC33072AD	4.11-4	MC33164P-5	4.2-15	MC33295	4.9-3
MC33072D	4.11-4	MC33165	4.2-9	MC33298	4.9-3
MC33074	4.1-6	MC33166	4.2-9	MC33298P	4.9-5
MC33074A	4.1-6	MC33167	4.2-9	MC3334	4.9-2
MC33074AD	4.11-4	MC33171	4.1-3	MC3335	4.7-2
MC33074D	4.11-4	MC33171D	4.11-4	MC3335DW	4.11-3
		MC33172	4.1-4		

# Device Index

MC3340	4.8-2	MC34012-1	4.7-17, 4.7-28	MC34065	4.2-11
MC3346	4.8-5	MC34012-1D	4.11-4	MC34065DW	4.11-5
MC3346D	4.11-3	MC34012-2	4.7-17, 4.7-28	MC34065DW-H	4.11-5
MC3356	4.7-2	MC34012-2D	4.11-4	MC34065DW-L	4.11-5
MC3356DW	4.11-3	MC34012-3	4.7-17, 4.7-28	MC34066	4.2-10
MC3357	4.7-2	MC34012-3D	4.11-4	MC34066DW	4.11-5
MC3358	4.1-4	MC34012D	4.7-17	MC34067	4.2-10
MC3359	4.7-2	MC34012P	4.7-17	MC34067DW	4.11-5
MC3359DW	4.11-3	MC34014	4.7-18, 4.7-28	MC34071	4.1-3
MC3361AD	4.11-3		4.7-29	MC34071A	4.1-3
MC3361B	4.7-2	MC34014DW	4.7-18, 4.11-4	MC34071D,AD	4.11-5
MC3362	4.7-2	MC34014P	4.7-18	MC34072	4.1-4
MC3362DW	4.11-3	MC34017	4.7-17, 4.7-29	MC34072A	4.1-4
MC3363	4.7-2	MC34017-1	4.7-17, 4.7-28	MC34072D,AD	4.11-5
MC3363DW	4.11-3	MC34017-1D	4.11-4	MC34074	4.1-5
MC3367	4.7-2	MC34017-2	4.7-17, 4.7-28	MC34074A	4.1-5
MC3367DW	4.11-3	MC34017-2D	4.11-4	MC34074D,AD	4.11-5
MC3371	4.7-2	MC34017-3	4.7-17, 4.7-28	MC34080	4.1-3
MC3371D	4.11-3	MC34017-3D	4.11-4	MC34080D	4.11-5
MC3372	4.7-2	MC34017D	4.7-17	MC34081	4.1-3
MC3372D	4.11-3	MC34017P	4.7-17	MC34081D	4.11-5
MC3373	4.8-25	MC34018	4.7-20, 4.7-23	MC34082	4.1-4
MC3373P	4.8-25		4.7-28, 4.7-29	MC34083	4.1-4
MC3391DW	4.11-3	MC34018DW	4.7-20, 4.11-4	MC34084	4.1-5
MC3392	4.9-3, 4.9-6	MC34018P	4.7-20	MC34084ADW	4.11-5
MC3392DW	4.9-6	MC34023	4.2-9	MC34084DW	4.11-5
MC3392T	4.9-6	MC34023DW	4.11-4	MC34085	4.1-5
MC3392T-2	4.9-6	MC34023FN	4.11-4	MC34085ADW	4.11-5
MC3399	4.9-3	MC34025	4.2-10	MC34085DW	4.11-5
MC3399T	4.3-3	MC34025DW	4.11-5	MC34114	4.7-28, 4.7-29
MC34001	4.1-3	MC34025FN	4.11-5	MC34114DW	4.7-19, 4.11-5
MC34001B	4.1-3	MC3403	4.1-5	MC34114P	4.7-19
MC34001BD	4.11-4	MC3403D	4.11-3	MC34115	4.7-27, 4.7-29
MC34001D	4.11-4	MC3405	4.1-8, 4.1-9	MC34115DW	4.11-5
MC34002	4.1-4	MC34050	4.6-7	MC34115P	4.7-27
MC34002B	4.1-4	MC34050D	4.11-5	MC34117	4.7-17
MC34002BD	4.11-4	MC34051	4.6-7	MC34118	4.7-22, 4.7-23
MC34002D	4.11-4	MC34051D	4.11-5		4.7-28, 4.7-29
MC34004	4.1-5	MC34055	4.6-8	MC34118DW	4.7-22, 4.11-5
MC34004B	4.1-5	MC34055DW	4.6-3	MC34118P	4.7-22
MC3401	4.1-5	MC34055P	4.6-3	MC34119	4.7-21, 4.7-22
MC3401D	4.11-3	MC34060A	4.2-7		4.7-28, 4.7-29, 4.8-2
MC34010	4.7-16, 4.7-28	MC34060AD	4.11-5	MC34119D	4.7-24, 4.11-5
	4.7-29	MC34063A	4.2-9	MC34119P	4.7-24
MC34010FN	4.7-16, 4.11-4	MC34063AD	4.11-5	MC34129	4.2-7, 4.7-11
MC34010P	4.7-16	MC34064	4.2-15		4.7-29
MC34012	4.7-17, 4.7-29	MC34064D-5	4.2-15, 4.11-5	MC34129D	4.11-5

# Device Index

MC34129D	4.7-24	MC34261D	4.2-12, 4.11-5	MC35072A	4.1-5
MC34129P	4.7-24	MC34261P	4.2-12	MC35074	4.1-6
MC34142	4.6-3, 4.6-8	MC34262	4.2-12, 4.2-13	MC35074A	4.1-6
MC34142DW	4.6-3	MC34262D	4.2-13	MC35080	4.1-3
MC34142FN	4.6-3	MC34262P	4.2-13	MC35081	4.1-3
MC34151	4.2-17	MC34268	4.2-6	MC35084	4.1-6
MC34151D	4.2-17, 4.11-5	MC3430	4.1-10	MC35085	4.1-6
MC34151P	4.2-17	MC3431	4.1-10	MC3517	4.7-27, 4.7-29
MC34152	4.2-17	MC3432	4.1-10	MC3517/18	4.7-27
MC34152D	4.2-17, 4.11-5	MC3433	4.1-10	MC3517/18L	4.7-27
MC34152P	4.2-17	MC3437	4.6-5	MC35171	4.1-3
MC34160	4.2-6, 4.2-16	MC3447	4.6-5	MC35172	4.1-5
MC34160P	4.2-16	MC3448A	4.6-5	MC35174	4.1-6
MC34161	4.2-16	MC3448AD	4.11-3	MC3518	4.7-27, 4.7-29
MC34161D	4.2-16, 4.11-5	MC3450	4.6-5, 4.6-6	MC3523U	4.2-14
MC34161P	4.2-16	MC3450D	4.11-3	MC3558	4.1-5
MC34163	4.2-9	MC3452	4.6-5, 4.6-6	MC4016	3.1-10, 3.1-24
MC34164	4.2-15	MC3452D	4.11-3	MC4018	3.1-10, 3.1-24
MC34164D-3	4.2-15, 4.11-5	MC3453	4.6-5, 4.6-6	MC4024	4.7-31
MC34164D-5	4.2-15, 4.11-5	MC3456D	4.11-3	MC4024	3.1-10, 3.1-24
MC34164P-3	4.2-15	MC3456L	4.10-2	MC4044	4.7-31
MC34164P-5	4.2-15	MC3456P	4.10-2	MC4044	3.1-10, 3.1-24
MC34165	4.2-9	MC3458	4.1-4	MC4316	4.7-31
MC34166	4.2-9	MC3458D	4.11-3	MC4316	3.1-10, 3.1-24
MC34167	4.2-9, 4.6-4	MC3470	4.6-4	MC4324	4.7-31
MC3417	4.7-27	MC3470A	4.6-4	MC4324	3.1-10, 3.1-24
MC3417/18L	4.7-27	MC3471	4.6-4	MC4344	4.7-31
MC3418	4.7-27, 4.7-29	MC3476	4.1-3	MC4344	3.1-10, 3.1-24
MC3418DW	4.11-3	MC3479P	4.3-9	MC44000	4.8-11, 4.8-13
MC34181	4.1-3	MC3481	4.6-6	MC44001	4.8-6, 4.8-10
MC34181D	4.11-5	MC3485	4.6-6	MC44001P	4.8-10
MC34182	4.1-4	MC3486	4.6-6	MC44011	4.8-11, 4.8-13
MC34182D	4.11-5	MC3486D	4.11-3	MC44011FN	4.8-11
MC34184	4.1-5	MC3487	4.6-5, 4.6-6	MC44106	4.8-6
MC34184D	4.11-5	MC3487D	4.11-3	MC44130	4.8-6
MC3419	4.7-9	MC3488A	4.6-6	MC44131	4.8-12
MC3419-1	4.7-28	MC35001B	4.1-3	MC44131P	4.8-12
MC3419-1L	4.7-7	MC35002	4.1-5	MC44140	4.8-3, 4.8-6
MC34217	4.7-28, 4.7-29	MC35002B	4.1-5		4.8-10, 4.8-13
MC34217D	4.7-18, 4.11-5	MC35004	4.1-6	MC44140DW	4.8-13
MC34217P	4.7-18	MC35004B	4.1-6	MC44140P	4.8-13
MC3423D	4.11-3	MC3503	4.1-6	MC44144	4.8-5, 4.8-14
MC3423P1	4.2-14	MC3505	4.1-8	MC44144D	4.8-14
MC3423U	4.2-14	MC35063A	4.2-9	MC44144P	4.8-14
MC3425	4.2-14	MC35071	4.1-3	MC44145	4.8-3, 4.8-5
MC3425P1	4.2-14	MC35071A	4.1-3		4.8-15
MC34261	4.2-12	MC35072	4.1-5	MC44145D	4.8-15

# Device Index

MC44200	4.8-3, 4.8-4 4.8-15	MC54HCT245A	3.1-49	MC54HC240A	3.1-47
MC44200FU	4.8-15	MC54HCT273A	3.1-49	MC54HC241A	3.1-47
MC44250	4.5-2, 4.8-3 4.8-4, 4.8-16	MC54HCT32A	3.1-49	MC54HC242	3.1-47
MC44250FN	4.11-6	MC54HCT373A	3.1-49	MC54HC244A	3.1-47
MC44251	4.8-3, 4.8-4 4.8-16	MC54HCT374A	3.1-49	MC54HC245A	3.1-47
MC44251FN	4.8-16	MC54HCT541	3.1-49	MC54HC251	3.1-47
MC44301	4.8-4, 4.8-6 4.8-17	MC54HCT573A	3.1-49	MC54HC253	3.1-47
MC44301DW	4.8-17, 4.11-5	MC54HCT574A	3.1-49	MC54HC257	3.1-47
MC44301P	4.8-17	MC54HCT640A	3.1-49	MC54HC259	3.1-47
MC44602	4.2-8, 4.8-6	MC54HCT74A	3.1-49	MC54HC27	3.1-46
MC44614	4.8-3	MC54HCU04	3.1-46	MC54HC273A	3.1-47
MC44615A	4.8-3	MC54HC00A	3.1-46	MC54HC280	3.1-47
MC448010	4.8-6	MC54HC02A	3.1-46	MC54HC299	3.1-47
MC448017	4.8-19	MC54HC03A	3.1-46	MC54HC30	3.1-46
MC448017D	4.8-19	MC54HC04A	3.1-46	MC54HC32A	3.1-46
MC44802/10	4.8-6	MC54HC08A	3.1-46	MC54HC365	3.1-47
MC44802A	4.8-4, 4.8-20	MC54HC10	3.1-46	MC54HC366	3.1-47
MC44802AP	4.8-18	MC54HC107	3.1-46	MC54HC367	3.1-47
MC44807	4.8-4, 4.8-19	MC54HC109	3.1-46	MC54HC368	3.1-47
MC44807P	4.8-19	MC54HC11	3.1-46	MC54HC373A	3.1-47
MC44810	4.8-4, 4.8-18 4.8-20	MC54HC112	3.1-46	MC54HC374A	3.1-47
MC44810P	4.8-20	MC54HC125A	3.1-46	MC54HC390	3.1-47
MC44817	4.8-4	MC54HC126A	3.1-46	MC54HC393	3.1-47
MC44818	4.8-4	MC54HC132A	3.1-46	MC54HC4002	3.1-48
MC44824	4.8-4	MC54HC133	3.1-46	MC54HC4016	3.1-48
MC4558	4.1-5	MC54HC137	3.1-46	MC54HC4017	3.1-48
MC4558AC	4.1-4	MC54HC138A	3.1-46	MC54HC4020	3.1-48
MC4558C	4.1-4	MC54HC139A	3.1-46	MC54HC4024	3.1-48
MC4558CD	4.11-3	MC54HC14A	3.1-46	MC54HC4040	3.1-48
MC4741	4.1-6	MC54HC147	3.1-46	MC54HC4046A	3.1-48
MC4741C	4.1-5	MC54HC151	3.1-46	MC54HC4049	3.1-48
MC4741CD	4.11-3	MC54HC153	3.1-46	MC54HC4050	3.1-48
MC54HCT00A	3.1-49	MC54HC154	3.1-47	MC54HC4051	3.1-48
MC54HCT04A	3.1-49	MC54HC157A	3.1-47	MC54HC4052	3.1-48
MC54HCT08A	3.1-49	MC54HC160	3.1-47	MC54HC4053	3.1-48
MC54HCT138A	3.1-49	MC54HC161A	3.1-47	MC54HC4060	3.1-48
MC54HCT14A	3.1-49	MC54HC162	3.1-47	MC54HC4066	3.1-48
MC54HCT157A	3.1-49	MC54HC163A	3.1-47	MC54HC4075	3.1-48
MC54HCT174A	3.1-49	MC54HC164	3.1-47	MC54HC4078	3.1-48
MC54HCT240A	3.1-49	MC54HC165	3.1-47	MC54HC42	3.1-46
MC54HCT241A	3.1-49	MC54HC173	3.1-47	MC54HC4316	3.1-48
MC54HCT244A	3.1-49	MC54HC174A	3.1-47	MC54HC4351	3.1-48
		MC54HC175	3.1-47	MC54HC4353	3.1-48
		MC54HC194	3.1-47	MC54HC4511	3.1-48
		MC54HC195	3.1-47	MC54HC4514	3.1-48
		MC54HC20	3.1-46	MC54HC4538A	3.1-48
		MC54HC237	3.1-47	MC54HC51	3.1-46

# Device Index

MC54HC534A	3.1-47	MC68EC040	2.2-13	MC68HC11A7	2.5-23
MC54HC540	3.1-47	MC68F333	2.5-42	MC68HC11A8	2.5-23, 2.5-41
MC54HC541	3.1-48	MC68HCB34	2.5-27	MC68HC11D0	2.5-23, 2.5-41
MC54HC563	3.1-48	MC68HC000	2.2-12	MC68HC11D3	2.5-23, 2.5-41
MC54HC564	3.1-48	MC68HC001	2.2-12	MC68HC11ED0	2.5-23
MC54HC573A	3.1-48	MC68HC04R1	4.8-6	MC68HC11E0	2.5-23, 2.5-41
MC54HC574A	3.1-48	MC68HC05	4.7-12	MC68HC11E1	2.5-23, 2.5-41
MC54HC58	3.1-46	MC68HC05B16	2.5-40	MC68HC11E2	2.5-41
MC54HC589	3.1-48	MC68HC05B4	2.5-7, 2.5-40	MC68HC11E8	2.5-23
MC54HC595A	3.1-48	MC68HC05B6	2.5-7, 2.5-40	MC68HC11E9	2.5-23, 2.5-41
MC54HC597	3.1-48	MC68HC05B8	2.5-7, 2.5-40	MC68HC11F1	2.5-23, 2.5-42
MC54HC640A	3.1-48	MC68HC05C12	2.5-7, 2.5-40	MC68HC11G5	2.5-42
MC54HC646	3.1-48	MC68HC05C4	2.5-7, 2.5-40	MC68HC11G7	2.5-41
MC54HC688	3.1-48	MC68HC05C4A	2.5-40	MC68HC11KA0	2.5-24
MC54HC7266	3.1-48	MC68HC05C5	2.5-7, 2.5-40	MC68HC11KA1	2.5-24
MC54HC73	3.1-46	MC68HC05C8	2.5-7, 2.5-40	MC68HC11KA3	2.5-24
MC54HC74A	3.1-46	MC68HC05C9	2.5-7, 2.5-40	MC68HC11KA4	2.5-24, 2.5-42
MC54HC75	3.1-46	MC68HC05D24	2.5-8, 2.4-40	MC68HC11K0	2.5-24, 2.5-42
MC54HC85	3.1-46	MC68HC05D9	2.5-7, 2.5-40	MC68HC11K1	2.5-24, 2.5-42
MC54HC86	3.1-46	MC68HC05E0	2.5-8	MC68HC11K3	2.5-24
MC660	3.1-54	MC68HC05E1	2.5-8, 2.5-40	MC68HC11K4	2.5-24, 2.5-42
MC661	3.1-54	MC68HC05F5	2.5-8	MC68HC11L0	2.5-24, 2.5-42
MC662	3.1-54	MC68HC05F6	2.5-8	MC68HC11L1	2.5-24, 2.5-42
MC663	3.1-54	MC68HC05G1	2.5-8, 2.5-40	MC68HC11L5	2.5-24
MC664	3.1-54	MC68HC05G3	2.5-8	MC68HC11L6	2.5-25, 2.5-42
MC667	3.1-54	MC68HC05J1	2.5-9, 2.5-40	MC68HC11M2	2.5-25, 2.5-42
MC668	3.1-54	MC68HC05J1A	2.5-9	MC68HC11N4	2.5-42
MC669	3.1-54	MC68HC05L10	2.5-10, 2.5-41	MC68HC11P2	2.5-42
MC670	3.1-54	MC68HC05L12	2.5-10	MC68HC16Y1	2.5-35, 2.5-42
MC671	3.1-54	MC68HC05L16	2.5-11	MC68HC16Z1	2.5-35, 2.5-42
MC672	3.1-54	MC68HC05L5	2.5-10, 2.5-41	MC68HC16Z2	2.5-35, 2.5-42
MC677	3.1-54	MC68HC05L7	2.5-10, 2.5-41	MC68HC24	2.5-27
MC678	3.1-54	MC68HC05L9	2.5-10, 2.5-41	MC68HC27	2.5-27
MC68B00	2.5-27	MC68HC05P1	2.5-11, 2.5-41	MC68HC68L9	2.5-28
MC68B09	2.5-27	MC68HC05P2	2.5-11	MC68HC705B16	2.5-13, 2.5-40
MC68B09E	2.5-27	MC68HC05P4	2.5-11, 2.5-41	MC68HC705B5	2.5-13, 2.5-40
MC68B10	2.5-27	MC68HC05P5	2.5-11	MC68HC705C8	2.5-13, 2.5-40
MC68B21	2.5-27	MC68HC05P6	2.5-11, 2.5-41	MC68HC705D9	2.5-40
MC68B40	2.5-27	MC68HC05P7	2.5-11, 2.5-41	MC68HC705E1	2.5-14, 2.5-40
MC68B44	2.5-27	MC68HC05P8	2.5-11, 2.5-41	MC68HC705G1	2.5-14
MC68B488	2.5-27	MC68HC05P9	2.5-11, 2.5-41	MC68HC705G4	2.5-14
MC68B50	2.5-27	MC68HC05T1	2.5-12, 2.5-41	MC68HC705J2	2.5-15, 2.5-40
MC68B52	2.5-27	MC68HC05T10	2.5-12, 2.5-41	MC68HC705L13	2.5-16
MC68B54	2.5-27	MC68HC05T7	2.5-12, 2.5-41	MC68HC705L16	2.5-16
MC68EC000	2.2-12	MC68HC11AA	2.5-41	MC68HC705L5	2.5-15, 2.5-41
MC68EC020	2.2-13	MC68HC11A0	2.5-23, 2.5-41	MC68HC705X16	2.5-16, 2.5-41
MC68EC030	2.2-13	MC68HC11A1	2.5-23	MC68HC711D3	2.5-41



# Device Index

MC68HC711E9	2.5-41	MC68331	2.2-13	MC74ACT158	3.1-52
MC68HC711G5	2.5-42	MC68332	2.5-38, 2.5-42	MC74ACT160	3.1-52
MC68HC711K4	2.5-42	MC68332	2.2-13	MC74ACT161	3.1-52
MC68HC711L6	2.5-42	MC68340	2.2-13	MC74ACT162	3.1-52
MC68HC711M2	2.5-42	MC68340V	2.2-13	MC74ACT163	3.1-52
MC68HC711N4	2.5-42	MC68360	4.6-8	MC74ACT174	3.1-52
MC68HC711P2	2.5-42	MC68360	2.2-13	MC74ACT175	3.1-52
MC68HC811AE2	2.5-41	MC68440	2.2-13	MC74ACT194	3.1-52
MC68HC811A8	2.5-41	MC6845	2.5-27	MC74ACT20	3.1-51
MC68HC811E2	2.5-23	MC68450	2.2-13	MC74ACT240	3.1-52
MC68LC040	2.2-13	MC68605	2.2-13	MC74ACT241	3.1-52
MC68000	4.7-13	MC68606	2.2-13	MC74ACT244	3.1-52
MC68000	2.2-12	MC68681	2.2-14	MC74ACT245	3.1-52
MC68008	2.2-12	MC68701	2.5-27, 2.5-40	MC74ACT251	3.1-52
MC6801	2.5-27, 2.5-40	MC68701U4	2.5-27, 2.5-40	MC74ACT253	3.1-52
MC6801U4	2.5-27, 2.5-40	MC6880A	4.6-4	MC74ACT256	3.1-52
MC68010	2.2-12	MC68824	2.2-14	MC74ACT258	3.1-52
MC6802	2.5-27	MC68836	2.2-14	MC74ACT259	3.1-52
MC68020	2.2-13	MC68837	2.2-14	MC74ACT273	3.1-52
MC6803	2.5-27, 2.5-40	MC68838	2.2-14	MC74ACT299	3.1-52
MC6803U4	2.5-27, 2.5-40	MC68839	2.2-14	MC74ACT32	3.1-51
MC68030	2.2-13	MC68851	2.2-14	MC74ACT323	3.1-52
MC68040	2.2-13	MC6887	4.6-4	MC74ACT350	3.1-52
MC68040V	2.2-13	MC6887	4.6-4	MC74ACT352	3.1-52
MC6805P2	2.5-28	MC6888	4.6-4	MC74ACT353	3.1-52
MC6805P6	2.5-28	MC68881	2.2-14	MC74ACT373	3.1-52
MC6805R2	2.5-28, 2.5-42	MC68882	2.2-14	MC74ACT374	3.1-52
MC6805R3	2.5-28, 2.5-42	MC68901	2.2-14	MC74ACT377	3.1-52
MC6805R6	2.5-28	MC74ACT00	3.1-51	MC74ACT378	3.1-52
MC6805S2	2.5-28	MC74ACT02	3.1-51	MC74ACT521	3.1-52
MC6805S3	2.5-28	MC74ACT04	3.1-51	MC74ACT533	3.1-52
MC6805U2	2.5-28	MC74ACT05	3.1-51	MC74ACT534	3.1-52
MC6805U3	2.5-28	MC74ACT08	3.1-51	MC74ACT540	3.1-52
MC68060	2.2-13	MC74ACT10	3.1-51	MC74ACT541	3.1-52
MC68160	4.6-2, 4.6-8	MC74ACT109	3.1-51	MC74ACT563	3.1-52
MC68160FB	4.6-2	MC74ACT11	3.1-51	MC74ACT564	3.1-52
MC68184	2.2-13	MC74ACT112	3.1-51	MC74ACT573	3.1-52
MC68185	2.2-13	MC74ACT113	3.1-51	MC74ACT574	3.1-53
MC68194	3.1-9, 3.1-23	MC74ACT125	3.1-51	MC74ACT620	3.1-53
MC68194	2.2-13	MC74ACT126	3.1-51	MC74ACT623	3.1-53
MC68195	2.2-13	MC74ACT132	3.1-51	MC74ACT640	3.1-53
MC68230	2.2-13	MC74ACT138	3.1-51	MC74ACT643	3.1-53
MC68302	4.7-11, 4.7-13	MC74ACT139	3.1-51	MC74ACT646	3.1-53
MC68302	2.2-13	MC74ACT14	3.1-51	MC74ACT648	3.1-53
MC68306	2.2-13	MC74ACT151	3.1-52	MC74ACT652	3.1-53
MC68330	2.2-13	MC74ACT153	3.1-52	MC74ACT74	3.1-51
MC68331	2.5-38, 2.5-42	MC74ACT157	3.1-52	MC74ACT810	3.1-53

# Device Index

MC74ACT86	3.1-51	MC74AC373	3.1-50	MC74F162A	3.1-31
MC74AC00	3.1-49	MC74AC374	3.1-50	MC74F163A	3.1-31
MC74AC02	3.1-49	MC74AC377	3.1-50	MC74F164	3.1-31
MC74AC04	3.1-49	MC74AC378	3.1-50	MC74F168	3.1-31
MC74AC05	3.1-49	MC74AC4020	3.1-51	MC74F169	3.1-31
MC74AC08	3.1-49	MC74AC4040	3.1-51	MC74F174	3.1-31
MC74AC10	3.1-49	MC74AC533	3.1-50	MC74F175	3.1-31
MC74AC109	3.1-49	MC74AC534	3.1-50	MC74F1803	3.1-7, 3.1-22
MC74AC11	3.1-49	MC74AC540	3.1-51		3.1-33
MC74AC112	3.1-49	MC74AC541	3.1-51	MC74F181	3.1-32
MC74AC113	3.1-49	MC74AC563	3.1-51	MC74F182	3.1-32
MC74AC125	3.1-50	MC74AC564	3.1-51	MC74F194	3.1-32
MC74AC126	3.1-50	MC74AC573	3.1-51	MC74F195	3.1-32
MC74AC132	3.1-50	MC74AC574	3.1-51	MC74F20	3.1-31
MC74AC138	3.1-50	MC74AC620	3.1-51	MC74F21	3.1-31
MC74AC139	3.1-50	MC74AC623	3.1-51	MC74F240	3.1-32
MC74AC14	3.1-49	MC74AC640	3.1-51	MC74F241	3.1-32
MC74AC151	3.1-50	MC74AC643	3.1-51	MC74F242	3.1-32
MC74AC153	3.1-50	MC74AC646	3.1-51	MC74F243	3.1-32
MC74AC157	3.1-50	MC74AC648	3.1-51	MC74F244	3.1-32
MC74AC158	3.1-50	MC74AC652	3.1-51	MC74F245	3.1-32
MC74AC160	3.1-50	MC74AC74	3.1-49	MC74F251	3.1-32
MC74AC161	3.1-50	MC74AC810	3.1-51	MC74F253	3.1-32
MC74AC162	3.1-50	MC74AC86	3.1-49	MC74F256	3.1-32
MC74AC163	3.1-50	MC74F00	3.1-31	MC74F257A	3.1-32
MC74AC174	3.1-50	MC74F02	3.1-31	MC74F258A	3.1-32
MC74AC175	3.1-50	MC74F04	3.1-31	MC74F259	3.1-32
MC74AC190	3.1-50	MC74F08	3.1-31	MC74F269	3.1-32
MC74AC194	3.1-50	MC74F10	3.1-31	MC74F280	3.1-32
MC74AC20	3.1-49	MC74F109	3.1-31	MC74F283	3.1-32
MC74AC240	3.1-50	MC74F11	3.1-31	MC74F299	3.1-32
MC74AC241	3.1-50	MC74F112	3.1-31	MC74F32	3.1-31
MC74AC244	3.1-50	MC74F1245	3.1-33	MC74F323	3.1-32
MC74AC245	3.1-50	MC74F125	3.1-31	MC74F350	3.1-32
MC74AC251	3.1-50	MC74F126	3.1-31	MC74F352	3.1-32
MC74AC253	3.1-50	MC74F13	3.1-31	MC74F353	3.1-32
MC74AC256	3.1-50	MC74F132	3.1-31	MC74F365	3.1-32
MC74AC257	3.1-50	MC74F138	3.1-31	MC74F366	3.1-32
MC74AC258	3.1-50	MC74F139	3.1-31	MC74F367	3.1-32
MC74AC259	3.1-50	MC74F14	3.1-31	MC74F368	3.1-32
MC74AC273	3.1-50	MC74F148	3.1-31	MC74F37	3.1-31
MC74AC299	3.1-50	MC74F151	3.1-31	MC74F373	3.1-32
MC74AC32	3.1-49	MC74F153	3.1-31	MC74F374	3.1-32
MC74AC323	3.1-50	MC74F157A	3.1-31	MC74F377	3.1-32
MC74AC350	3.1-50	MC74F158A	3.1-31	MC74F378	3.1-32
MC74AC352	3.1-50	MC74F160A	3.1-31	MC74F379	3.1-32
MC74AC353	3.1-50	MC74F161A	3.1-31	MC74F38	3.1-31

# Device Index

MC74F381	3.1-32	MC74HCT32A	3.1-49	MC74HC242	3.1-47
MC74F382	3.1-32	MC74HCT373A	3.1-49	MC74HC244A	3.1-47
MC74F3893A	3.1-33	MC74HCT374A	3.1-49	MC74HC245A	3.1-47
MC74F398	3.1-32	MC74HCT541	3.1-49	MC74HC251	3.1-47
MC74F399	3.1-32	MC74HCT573A	3.1-49	MC74HC253	3.1-47
MC74F40	3.1-31	MC74HCT574A	3.1-49	MC74HC257	3.1-47
MC74F51	3.1-31	MC74HCT640A	3.1-49	MC74HC259	3.1-47
MC74F521	3.1-32	MC74HCT74A	3.1-49	MC74HC27	3.1-46
MC74F533	3.1-32	MC74HCU04	3.1-46	MC74HC273A	3.1-47
MC74F534	3.1-32	MC74HC00A	3.1-46	MC74HC280	3.1-47
MC74F537	3.1-33	MC74HC02A	3.1-46	MC74HC299	3.1-47
MC74F538	3.1-33	MC74HC03A	3.1-46	MC74HC30	3.1-46
MC74F539	3.1-33	MC74HC04A	3.1-46	MC74HC32A	3.1-46
MC74F543	3.1-33	MC74HC08A	3.1-46	MC74HC365	3.1-47
MC74F544	3.1-33	MC74HC10	3.1-46	MC74HC366	3.1-47
MC74F568	3.1-33	MC74HC107	3.1-46	MC74HC367	3.1-47
MC74F569	3.1-33	MC74HC109	3.1-46	MC74HC368	3.1-47
MC74F574	3.1-33	MC74HC11	3.1-46	MC74HC373A	3.1-47
MC74F579	3.1-33	MC74HC112	3.1-46	MC74HC374A	3.1-47
MC74F620	3.1-33	MC74HC125A	3.1-46	MC74HC390	3.1-47
MC74F623	3.1-33	MC74HC126A	3.1-46	MC74HC393	3.1-47
MC74F64	3.1-31	MC74HC132A	3.1-46	MC74HC4002	3.1-48
MC74F640	3.1-33	MC74HC133	3.1-46	MC74HC4016	3.1-48
MC74F646	3.1-33	MC74HC137	3.1-46	MC74HC4017	3.1-48
MC74F657A	3.1-33	MC74HC138A	3.1-46	MC74HC4020	3.1-48
MC74F657B	3.1-33	MC74HC139A	3.1-46	MC74HC4024	3.1-48
MC74F74	3.1-31	MC74HC14A	3.1-46	MC74HC4040	3.1-48
MC74F779	3.1-33	MC74HC147	3.1-46	MC74HC4046A	3.1-48
MC74F803	3.1-7, 3.1-22	MC74HC151	3.1-46	MC74HC4049	3.1-48
	3.1-33	MC74HC153	3.1-46	MC74HC4050	3.1-48
MC74F823	3.1-33	MC74HC154	3.1-47	MC74HC4051	3.1-48
MC74F827	3.1-33	MC74HC157A	3.1-47	MC74HC4052	3.1-48
MC74F828	3.1-33	MC74HC160	3.1-47	MC74HC4053	3.1-48
MC74F85	3.1-31	MC74HC161A	3.1-47	MC74HC4060	3.1-48
MC74F86	3.1-31	MC74HC162	3.1-47	MC74HC4066	3.1-48
MC74HCT00A	3.1-49	MC74HC163A	3.1-47	MC74HC4075	3.1-48
MC74HCT04A	3.1-49	MC74HC164	3.1-47	MC74HC4078	3.1-48
MC74HCT08A	3.1-49	MC74HC165	3.1-47	MC74HC42	3.1-46
MC74HCT138A	3.1-49	MC74HC173	3.1-47	MC74HC4316	3.1-48
MC74HCT14A	3.1-49	MC74HC174A	3.1-47	MC74HC4351	3.1-48
MC74HCT157A	3.1-49	MC74HC175	3.1-47	MC74HC4353	3.1-48
MC74HCT174A	3.1-49	MC74HC194	3.1-47	MC74HC4511	3.1-48
MC74HCT240A	3.1-49	MC74HC195	3.1-47	MC74HC4514	3.1-48
MC74HCT241A	3.1-49	MC74HC20	3.1-46	MC74HC4538A	3.1-48
MC74HCT244A	3.1-49	MC74HC237	3.1-47	MC74HC51	3.1-46
MC74HCT245A	3.1-49	MC74HC240A	3.1-47	MC74HC534A	3.1-47
MC74HCT273A	3.1-49	MC74HC241A	3.1-47	MC74HC540	3.1-47

# Device Index

MC74HC541	3.1-48	MC78M12CDT	4.11-3	MC79L18AC	4.2-4
MC74HC563	3.1-48	MC78M15C	4.2-4	MC79L18C	4.2-4
MC74HC564	3.1-48	MC78M15CDT	4.11-3	MC79L24AC	4.2-4
MC74HC573A	3.1-48	MC78M18C	4.2-4	MC79L24C	4.2-4
MC74HC574A	3.1-48	MC78M20C	4.2-4	MC79M05BC	4.2-2
MC74HC58	3.1-46	MC78M24C	4.2-4	MC79M05C	4.2-2
MC74HC589	3.1-48	MC78T05AC	4.2-3	MC79M05CDT	4.11-3
MC74HC595A	3.1-48	MC78T05C	4.2-3	MC79M08	4.2-3
MC74HC597	3.1-48	MC78T08C	4.2-3	MC79M12BC	4.2-4
MC74HC640A	3.1-48	MC78T12AC	4.2-4	MC79M12C	4.2-4
MC74HC646	3.1-48	MC78T12C	4.2-4	MC79M12CDT	4.11-3
MC74HC688	3.1-48	MC78T15AC	4.2-4	MC79M15BC	4.2-4
MC74HC7266	3.1-48	MC78T15C	4.2-4	MC79M15C	4.2-4
MC74HC73	3.1-46	MC7805AC	4.2-3	MC79M15CDT	4.11-3
MC74HC74A	3.1-46	MC7805B	4.2-3	MC7905.2C	4.2-3
MC74HC75	3.1-46	MC7805C	4.2-3	MC7905AC	4.2-3
MC74HC85	3.1-46	MC7806AC	4.2-3	MC7905C	4.2-3
MC74HC86	3.1-46	MC7806B	4.2-3	MC7906C	4.2-3
MC75S110	4.6-5, 4.6-6	MC7806C	4.2-3	MC7908C	4.2-3
MC75107	4.6-5, 4.6-6	MC7808AC	4.2-3	MC7912C	4.2-4
MC75108	4.6-5, 4.6-6	MC7808B	4.2-3	MC7915C	4.2-4
MC75172B	4.6-6	MC7808C	4.2-3	MC7918C	4.2-4
MC75172BDW	4.11-5	MC7809C	4.2-3	MC7924C	4.2-5
MC75174B	4.6-6	MC7812AC	4.2-4	MC8HC705G1	2.5-40
MC75174BDW	4.11-5	MC7812B	4.2-4	MC8T26A	4.6-4
MC78L05AC	4.2-2	MC7812C	4.2-4	MC8T97	4.6-4
MC78L05ACD	4.11-3	MC7815AC	4.2-4	MC8T98	4.6-4
MC78L05C	4.2-2	MC7815B	4.2-4	MC830	3.1-54
MC78L08AC	4.2-3	MC7815C	4.2-4	MC832	3.1-54
MC78L08ACD	4.11-3	MC7818AC	4.2-4	MC836	3.1-54
MC78L08C	4.2-3	MC7818B	4.2-4	MC837	3.1-54
MC78L12AC	4.2-3	MC7818C	4.2-4	MC840	3.1-54
MC78L12ACD	4.11-3	MC7824AC	4.2-5	MC844	3.1-54
MC78L12C	4.2-3	MC7824B	4.2-5	MC845	3.1-54
MC78L15AC	4.2-4	MC7824C	4.2-5	MC846	3.1-54
MC78L15ACD	4.11-3	MC79L05AB	4.2-2	MC849	3.1-54
MC78L15C	4.2-4	MC79L05AC	4.2-2	MC88100	2.3-3
MC78L18AC	4.2-4	MC79L05ACD	4.11-3	MC88100RC	2.3-2
MC78L18C	4.2-4	MC79L05C	4.2-2	MC88110	2.3-3
MC78L24AC	4.2-4	MC79L12AB	4.2-3	MC88110RC	2.3-2
MC78L24C	4.2-4	MC79L12AC	4.2-3	MC88200	2.3-2, 2.3-3
MC78M05C	4.2-2	MC79L12ACD	4.11-3	MC88200RC	2.3-3
MC78M05CDT	4.11-3	MC79L12C	4.2-3	MC88204RC	2.3-3
MC78M06C	4.2-3	MC79L15AB	4.2-4	MC88410	2.3-3
MC78M08C	4.2-3	MC79L15AC	4.2-4	MC88913	3.1-7, 3.1-22
MC78M08CDT	4.11-3	MC79L15ACD	4.11-3	MC88914	3.1-7, 3.1-22
MC78M12C	4.2-4	MC79L15C	4.2-4	MC88915T100	3.1-7, 3.1-22

# Device Index

MC88915T133	3.1-8, 3.1-22	MGB20N40CL	5.4-23	MHW607-3	5.10-25
MC88915T160	3.1-8, 3.1-22	MGP20N35CL	5.4-23	MHW607-4	5.10-25
MC88915T55	3.1-7, 3.1-22	MGP20N40CL	5.4-23	MHW6122	5.10-28
MC88915T70	3.1-7, 3.1-22	MG8MEVB16Y1	2.5-42	MHW6142	5.10-28
MC8891555	3.1-7, 3.1-22	MHPM7A12A120A	5.3-2	MHW6172	5.10-28
MC8891570	3.1-7, 3.1-22	MHPM7A15A60A	5.3-2	MHW6182	5.10-28
MC8891670	3.1-8, 3.1-22	MHPM7A16A120B	5.3-2	MHW6182-6	5.10-28
MC8891680	3.1-8, 3.1-22	MHPM7A20A60A	5.3-2	MHW6183	5.10-28
MC88920	3.1-8, 3.1-22	MHPM7A30A60B	5.3-2	MHW6185-6	5.10-28
MC88921	3.1-8, 3.1-22	MHPM7A8A120A	5.3-2	MHW6185B	5.10-28
MC936	3.1-54	MHQ2222X/NBP	6.4-31	MHW6205	5.10-28
MC937	3.1-54	MHQ2369	6.3-5	MHW6222	5.10-28
MC944	3.1-54	MHQ2369HX	6.3-16	MHW6222-6	5.10-28
MC945	3.1-54	MHQ2369X/NBP	6.4-31	MHW6225	5.10-28
MC946	3.1-54	MHQ2484	6.3-5	MHW6272	5.10-28
MC951	3.1-54	MHQ2484HX	6.3-16	MHW6342	5.10-28
MC952	3.1-54	MHQ2907X/NBP	6.4-31	MHW704-1	5.10-25
MC953	3.1-54	MHQ3251A	6.3-5	MHW704-2	5.10-25
MD2369A	6.3-5	MHQ3251AHX	6.3-16	MHW707-1	5.10-25
MD2369AB/NBP	6.4-30	MHQ3467X/NBP	6.4-31	MHW707-2	5.10-25
MD2369AHX	6.3-16	MHQ3468	6.3-5	MHW707-3	5.10-25
MD2369HXV	6.3-16	MHQ3468HX	6.3-16	MHW707-4	5.10-25
MD3251A	6.3-5	MHQ3468HXV	6.3-16	MHW7182	5.10-29
MD3251AHX	6.3-16	MHQ3735X/NBP	6.4-31	MHW720A1	5.10-25
MD3251HXV	6.3-16	MHQ6002	6.3-5	MHW720A2	5.10-25
MD3468	6.3-5	MHQ6002HX	6.3-16	MHW720A3	5.10-25
MD3468HX	6.3-16	MHQ6002HXV	6.3-16	MHW7222	5.10-29
MD3468HXV	6.3-16	MHQ6002X/NBP	6.4-31	MHW803-1	5.10-25
MD5000AX/NBP	6.4-30	MHQ918	6.3-5	MHW803-2	5.10-25
MD6002	6.3-5	MHQ918HX	6.3-16	MHW803-3	5.10-25
MD6002HX	6.3-16	MHW105	5.10-25	MHW804-1	5.10-25
MD6002HXV	6.3-16	MHW1134	5.10-27	MHW804-2	5.10-25
MD6003B/NBP	6.4-30	MHW1224	5.10-27	MHW806A1	5.10-25
MD918	6.3-5	MHW5122A	5.10-27	MHW806A2	5.10-25
MD918AB/NBP	6.4-30	MHW5142A	5.10-27	MHW806A3	5.10-25
MD918HX	6.3-16	MHW5172A	5.10-27	MHW806A4	5.10-25
MD918HXV	6.3-16	MHW5182A	5.10-27	MHW812A3	5.10-25
MFF124B	5.10-27	MHW5183	5.10-27	MHW8182	5.10-29
MFF224B	5.10-28	MHW5185B	5.10-27	MHW8222	5.10-29
MFF324B	5.10-28	MHW5205	5.10-27	MHW851-1	5.10-25
MFOD71	5.8-16	MHW5222A	5.10-27	MHW851-2	5.10-25
MFOD72	5.8-16	MHW5225	5.10-27	MHW851-3	5.10-25
MFOD73	5.8-16	MHW5272A	5.10-27	MHW851-4	5.10-25
MFOD75	5.8-16	MHW5342A	5.10-27	MHW9002-1	5.10-25
MFOE71	5.8-16	MHW5382A	5.10-27	MHW9002-2	5.10-25
MFOE76	5.8-16	MHW607-1	5.10-25	MHW9002-3	5.10-25
MGB20N35CL	5.4-23	MHW607-2	5.10-25	MHW9002-4	5.10-25

# Device Index

MHW903	5.10-26	MJE15029	5.5-6	MJE5731A	5.5-4
MHW909	5.10-26	MJE15030	5.5-18	MJE5740	5.5-6
MHW912	5.10-26	MJE15030	5.5-6	MJE5741	5.5-6
MHW914	5.10-26	MJE15031	5.5-18	MJE5742	5.5-6
MHW915	5.10-26	MJE15031	5.5-6	MJE5850	5.5-6
MHW9182	5.10-29	MJE16002	5.5-5	MJE5851	5.5-6
MHW927A	5.10-26	MJE16004	5.5-5	MJE5852	5.5-6
MHW927B	5.10-26	MJE16106	5.5-6	MJE700	5.5-11
MHW932	5.10-26	MJE16204	5.5-5, 5.5-20	MJE700T	5.5-5
MHW953	5.10-26	MJE171	5.5-11	MJE702	5.5-12
MHW954	5.10-26	MJE172	5.5-11	MJE703	5.5-12
MJD112	5.5-13	MJE18002	5.5-4	MJE800	5.5-11
MJD117	5.5-13	MJE18004	5.5-5	MJE800T	5.5-5
MJD122	5.5-13	MJE18006	5.5-5	MJE802	5.5-12
MJD127	5.5-13	MJE18008	5.5-6	MJE803	5.5-12
MJD13003	5.5-12	MJE18009	5.5-7	MJE8503A	5.5-5
MJD148	5.5-13	MJE181	5.5-11	MJE9780	5.5-4
MJD200	5.5-13	MJE182	5.5-11	MJF122	5.5-3
MJD210	5.5-13	MJE18204	5.5-5	MJF127	5.5-3
MJD243	5.5-13	MJE200	5.5-12	MJF13007	5.5-3
MJD253	5.5-13	MJE210	5.5-12	MJF13009	5.5-3
MJD2955	5.5-13	MJE2360T	5.5-4	MJF15030	5.5-3
MJD3055	5.5-13	MJE2361T	5.5-4	MJF15031	5.5-3
MJD31	5.5-13	MJE240	5.5-12	MJF16002	5.5-3
MJD31C	5.5-13	MJE241	5.5-12	MJF16204	5.5-3, 5.5-20
MJD32	5.5-13	MJE243	5.5-12	MJF18002	5.5-3
MJD32C	5.5-13	MJE250	5.5-12	MJF18004	5.5-3
MJD340	5.5-12	MJE251	5.5-12	MJF18006	5.5-3
MJD350	5.5-12	MJE253	5.5-12	MJF18008	5.5-3
MJD41C	5.5-13	MJE270	5.5-11	MJF18009	5.5-3
MJD42C	5.5-13	MJE271	5.5-11	MJF18204	5.5-3
MJD44E3	5.5-13	MJE2955T	5.5-6	MJF2955	5.5-3
MJD44H11	5.5-13	MJE3055T	5.5-6	MJF3055	5.5-3
MJD45H11	5.5-13	MJE340	5.5-10	MJF31C	5.5-3
MJD47	5.5-12	MJE341	5.5-10	MJF32C	5.5-3
MJD50	5.5-12	MJE3439	5.5-10	MJF44H11	5.5-3
MJD5731	5.5-12	MJE344	5.5-10	MJF45H11	5.5-3
MJD6036	5.5-13	MJE350	5.5-10	MJF47	5.5-3
MJD6039	5.5-13	MJE371	5.5-11	MJF6107	5.5-3
MJE1123	5.5-5	MJE4342	5.5-8	MJF6388	5.5-3
MJE13002	5.5-11	MJE4343	5.5-8	MJF6668	5.5-3
MJE13003	5.5-11	MJE4352	5.5-8	MJH10012	5.5-7
MJE13005	5.5-5	MJE4353	5.5-8	MJH11017	5.5-8
MJE13007	5.5-6	MJE521	5.5-11	MJH11018	5.5-8
MJE13009	5.5-7	MJE5420Z	5.5-6	MJH11019	5.5-8
MJE1320	5.5-4	MJE5730	5.5-4	MJH11020	5.5-8
MJE15028	5.5-6	MJE5731	5.5-4	MJH11021	5.5-8

# Device Index

MJH11022	5.5-8	MJ10021	5.5-17	MJ15003	5.5-15, 5.5-18
MJH16002	5.5-7	MJ10022	5.5-16	MJ15004	5.5-15, 5.5-18
MJH16002A	5.5-7	MJ10023	5.5-16	MJ15011	5.5-14
MJH16004	5.5-7	MJ11011	5.5-16	MJ15012	5.5-14
MJH16006	5.5-7	MJ11012	5.5-16	MJ15012A/NBP	6.4-30
MJH16006A	5.5-7	MJ11012A/NBP	6.4-29	MJ15015	5.5-14, 5.5-18
MJH16008	5.5-7	MJ11013	5.5-16	MJ15015A/NBP	6.4-30
MJH6282	5.5-8	MJ11014	5.5-16	MJ15016	5.5-14, 5.5-18
MJH6283	5.5-8	MJ11015	5.5-16	MJ15018	5.5-13
MJH6284	5.5-8	MJ11016	5.5-16	MJ15019	5.5-13
MJH6285	5.5-8	MJ11017	5.5-14	MJ15020	5.5-13, 5.5-18
MJH6286	5.5-8	MJ11018	5.5-14	MJ15021	5.5-13, 5.5-18
MJH6287	5.5-8	MJ11019	5.5-15	MJ15022	5.5-15
MJL1302A	5.5-10, 5.5-18	MJ11020	5.5-14	MJ15022A/FBP	6.4-30
MJL16218	5.5-20	MJ11021	6.3-5	MJ15023	5.5-15
MJL16218	5.5-10	MJ11021	5.5-15	MJ15023A/FBP	6.4-30
MJL21193	5.5-10, 5.5-18	MJ11021HX	6.3-14	MJ15024	5.5-15, 5.5-18
MJL21194	5.5-10, 5.5-18	MJ11021HXV	6.3-14	MJ15025	5.5-15, 5.5-18
MJL3281A	5.5-10, 5.5-18	MJ11022	6.3-5	MJ16002A	5.5-13
MJW16010	5.5-9	MJ11022	5.5-15	MJ16006	5.5-14
MJW16010A	5.5-9	MJ11022HX	6.3-14	MJ16006A	5.5-14
MJW16012	5.5-9	MJ11022HXV	6.3-14	MJ16008	5.5-14
MJW16018	5.5-9	MJ11028	5.5-16	MJ16010	5.5-15
MJW16110	5.5-9	MJ11029	5.5-16	MJ16010A	5.5-15
MJW16206	5.5-9, 5.5-20	MJ11030	5.5-16	MJ16012	5.5-15
MJW16210	5.5-9, 5.5-20	MJ11031	5.5-16	MJ16012A/NBP	6.4-30
MJW16212	5.5-9, 5.5-20	MJ11032	6.3-5	MJ16014	5.5-15
MJW6678	5.5-9	MJ11032	5.5-16	MJ16016	5.5-15
MJ1000	5.5-13	MJ11032HX	6.3-14	MJ16018	5.5-14
MJ10000	5.5-15	MJ11032HXV	6.3-14	MJ16018A/NBP	6.4-30
MJ10001	5.5-15	MJ11033	6.3-5	MJ16020	5.5-16
MJ10004	5.5-15	MJ11033	5.5-16	MJ16022	5.5-16
MJ10005	5.5-15	MJ11033HX	6.3-14	MJ16110	5.5-15
MJ10005A/NBP	6.4-29	MJ11033HXV	6.3-14	MJ21193	5.5-15, 5.5-18
MJ10007	5.5-14	MJ13014	5.5-14	MJ21194	5.5-15, 5.5-18
MJ10008	5.5-15	MJ13015	5.5-14	MJ2500	5.5-14
MJ10009	5.5-15	MJ1302A	5.5-15, 5.5-18	MJ2501	5.5-14
MJ1001	5.5-13	MJ13333	5.5-15	MJ2501A/NBP	6.4-30
MJ10012	5.5-14	MJ13335	5.5-15	MJ2955	5.5-14
MJ10014	5.5-14	MJ14000	5.5-17	MJ2955A	5.5-18
MJ10015	5.5-17	MJ14001	5.5-17	MJ2955A	5.5-14
MJ10016	6.3-5	MJ14002	5.5-17	MJ2955A/NBP	6.4-30
MJ10016	5.5-17	MJ14003	5.5-17	MJ3000	5.5-14
MJ10016A/NBP	6.4-29	MJ15001	5.5-14, 5.5-18	MJ3001	5.5-14
MJ10016HX	6.3-14	MJ15001A/NBP	6.4-30	MJ3001A/NBP	6.4-30
MJ10016HXV	6.3-14	MJ15002	5.5-14, 5.5-18	MJ3041	5.5-14
MJ10020	5.5-17	MJ15002A/NBP	6.4-30	MJ3281A	5.5-15, 5.5-18

# Device Index

MJ413	5.5-14	MMBD301LT1	5.1-33	MMBR931LT1	5.1-15
MJ423	5.5-14	MMBD352LT1	5.1-33	MMBR941BLT1	5.10-16
MJ4502	5.5-16	MMBD353LT1	5.1-33	MMBR941LT1	5.10-16, 5.10-18
MJ4502A/NBP	6.4-30	MMBD354LT1	5.1-33	MMBR941LT1	5.1-15
MJ4647A/NBP	6.4-30	MMBD6050LT1	5.1-35	MMBR951ALT1	5.10-16
MJ6308	5.5-13	MMBD6100LT1	5.1-36	MMBR951LT1	5.10-16, 5.10-18
MJ6316	6.3-5	MMBD7000LT1	5.1-36	MMBR951LT1	5.1-15
MJ6316HX	6.3-14	MMBD7011LT1	5.1-33	MMBTA06LT1	5.1-14
MJ6316HXV	6.3-14	MMBD914LT1	5.1-35	MMBTA13LT1	5.1-13
MJ6318	6.3-5	MMBFJ175LT1	5.1-24	MMBTA14LT1	5.1-13
MJ6318HX	6.3-14	MMBFJ177LT1	5.1-24	MMBTA42LT1	5.1-14
MJ6318HXV	6.3-14	MMBFJ309LT1	5.1-23	MMBTA56LT1	5.1-14
MJ6503	5.5-14	MMBFJ310LT1	5.1-23	MMBTA64LT1	5.1-13
MJ802	5.5-16	MMBFU310LT1	5.1-23	MMBTA92LT1	5.1-14
MJ900	5.5-13	MMBF170LT1	5.1-24	MMBTH10LT1	5.1-13
MJ901	5.5-13	MMBF4391LT1	5.1-24	MMBTH24LT1	5.1-13
MKP1V120	5.7-17	MMBF4392LT1	5.1-24	MMBTH69LT1	5.1-13
MKP1V130	5.7-17	MMBF4393LT1	5.1-24	MMBTH81LT1	5.1-13
MKP1V140	5.7-17	MMBF4416LT1	5.1-23	MMBT2222ALT1	5.1-10
MKP1V240	5.7-17	MMBF4856LT1	5.1-24	MMBT2369LT1	5.1-12
MKP1V260	5.7-17	MMBF4860LT1	5.1-24	MMBT2484LT1	5.1-14
MKP1V270	5.7-17	MMBF5457LT1	5.1-23	MMBT2907ALT1	5.1-10
MKP3V110	5.7-17	MMBF5459LT1	5.1-23	MMBT3640LT1	5.1-12
MKP3V120	5.7-17	MMBF5460LT1	5.1-23	MMBT3904LT1	5.1-10
MKP3V130	5.7-17	MMBF5484LT1	5.1-23	MMBT3906LT1	5.1-11
MKP3V240	5.7-17	MMBF5486LT1	5.1-23	MMBT404ALT1	5.1-13
MKP3V260	5.7-17	MMBR2060LT1	5.1-15	MMBT4401LT1	5.1-10
MKP3V270	5.7-17	MMBR2857LT1	5.1-15	MMBT4403LT1	5.1-11
MLED81	5.8-14	MMBR4957LT1	5.10-16, 5.10-19	MMBT5087LT1	5.1-14
MLED91	5.8-14	MMBR4957LT1	5.1-15	MMBT5089LT1	5.1-14
MLED930	5.8-14	MMBR5031LT1	5.10-16, 5.10-19	MMBT5401LT1	5.1-14
MLED96	5.8-14	MMBR5031LT1	5.1-15	MMBT5551LT1	5.1-14
MLED97	5.8-14	MMBR5179LT1	5.10-16, 5.10-19	MMBT6428LT1	5.1-14
MLP1N06CL	5.4-23	MMBR5179LT1	5.1-15	MMBT6429LT1	5.1-14
MLP2N06CL	5.4-23	MMBR5211LT1	5.10-16, 5.10-18	MMBT6517LT1	5.1-14
MMAD1103	5.1-38	MMBR536LT1	5.10-16	MMBT6520LT1	5.1-14
MMAD1105	5.1-38	MMBR536LT1	5.1-15	MMBT8099LT1	5.1-10
MMAD1106	5.1-38	MMBR571LT1	5.10-16, 5.10-18	MMBT8599LT1	5.1-10
MMAD1107	5.1-38	MMBR571LT1	5.1-15	MMBT918LT1	5.1-13
MMAD1108	5.1-38	MMBR901LT1	5.10-16, 5.10-18	MMBV105GLT1	5.1-31
MMAD1109	5.1-38	MMBR901LT1	5.1-15	MMBV109LT1	5.1-31
MMAD130	5.1-38	MMBR911LT1	5.10-16, 5.10-18	MMBV2101LT1	5.1-28
MMBD101LT1	5.1-33	MMBR911LT1	5.1-15	MMBV2103LT1	5.1-28
MMBD2835LT1	5.1-36	MMBR920LT1	5.10-16, 5.10-19	MMBV2104LT1	5.1-28
MMBD2836LT1	5.1-36	MMBR920LT1	5.1-15	MMBV2105LT1	5.1-28
MMBD2837LT1	5.1-36	MMBR930LT1	5.1-15	MMBV2107LT1	5.1-28
MMBD2838LT1	5.1-36	MMBR931LT1	5.10-16	MMBV2108LT1	5.1-28



# Device Index

MMBV2109LT1	5.1-28	MMBZ5258BLT1	5.2-22, 5.2-25	MMSF5N03HD	5.4-3, 5.4-4
MMBV3102LT1	5.1-31	MMBZ5259BLT1	5.2-22, 5.2-25	MMSF6N01HD	5.4-3, 5.4-4
MMBV3401LT1	5.1-35	MMBZ5260BLT1	5.2-22, 5.2-25	MMSZ10T1	5.2-21, 5.2-29
MMBV3700LT1	5.1-35	MMBZ5261BLT1	5.2-22, 5.2-26	MMSZ11T1	5.2-21, 5.2-29
MMBV409LT1	5.1-31	MMBZ5262BLT1	5.2-22, 5.2-26	MMSZ12T1	5.2-21, 5.2-29
MMBV432LT1	5.1-28	MMBZ5263BLT1	5.2-22, 5.2-26	MMSZ13T1	5.2-21, 5.2-29
MMBV609LT1	5.1-32	MMBZ5264BLT1	5.2-22, 5.2-26	MMSZ15T1	5.2-21, 5.2-29
MMBV809LT1	5.1-31	MMBZ5265BLT1	5.2-22, 5.2-26	MMSZ16T1	5.2-21, 5.2-29
MMBZ15VDLT1	5.2-9	MMBZ5266BLT1	5.2-22, 5.2-26	MMSZ18T1	5.2-21, 5.2-29
MMBZ5V6ALT1	5.2-9	MMBZ5267BLT1	5.2-22, 5.2-26	MMSZ2V4T1	5.2-21, 5.2-29
MMBZ5221BLT1	5.2-21, 5.2-25	MMBZ5268BLT1	5.2-22, 5.2-26	MMSZ2V7T1	5.2-21, 5.2-29
MMBZ5222BLT1	5.2-21, 5.2-25	MMBZ5269BLT1	5.2-22, 5.2-26	MMSZ20T1	5.2-21, 5.2-29
MMBZ5223BLT1	5.2-21, 5.2-25	MMBZ5270BLT1	5.2-22, 5.2-26	MMSZ22T1	5.2-21, 5.2-29
MMBZ5224BLT1	5.2-21, 5.2-25	MMDF1N05E	5.4-3, 5.4-4	MMSZ24T1	5.2-21, 5.2-29
MMBZ5225BLT1	5.2-21, 5.2-25	MMDF2C01HD	5.4-3, 5.4-4	MMSZ27T1	5.2-21, 5.2-30
MMBZ5226BLT1	5.2-21, 5.2-25	MMDF2C02E	5.4-3, 5.4-4	MMSZ3V0T1	5.2-21, 5.2-29
MMBZ5227BLT1	5.2-21, 5.2-25	MMDF2C03HD	5.4-3, 5.4-4	MMSZ3V3T1	5.2-21, 5.2-29
MMBZ5228BLT1	5.2-21, 5.2-25	MMDF2N02E	5.4-3, 5.4-4	MMSZ3V6T1	5.2-21, 5.2-29
MMBZ5229BLT1	5.2-21, 5.2-25	MMDF2P01HD	5.4-3, 5.4-14	MMSZ3V9T1	5.2-21, 5.2-29
MMBZ5230BLT1	5.2-21, 5.2-25	MMDF2P02E	5.4-3, 5.4-14	MMSZ30T1	5.2-22, 5.2-30
MMBZ5231BLT1	5.2-21, 5.2-25	MMDF2P03HD	5.4-3, 5.4-14	MMSZ33T1	5.2-22, 5.2-30
MMBZ5232BLT1	5.2-21, 5.2-25	MMDF3N02HD	5.4-3, 5.4-4	MMSZ36T1	5.2-22, 5.2-30
MMBZ5233BLT1	5.2-21, 5.2-25	MMDF3N03HD	5.4-3, 5.4-4	MMSZ39T1	5.2-22, 5.2-30
MMBZ5234BLT1	5.2-21, 5.2-25	MMDF4N01HD	5.4-3, 5.4-4	MMSZ4V3T1	5.2-21, 5.2-29
MMBZ5235BLT1	5.2-21, 5.2-25	MMFT1N10E	5.4-5	MMSZ4V7T1	5.2-21, 5.2-29
MMBZ5236BLT1	5.2-21, 5.2-25	MMFT107T1	5.1-24	MMSZ43T1	5.2-22, 5.2-30
MMBZ5237BLT1	5.2-21, 5.2-25	MMFT2N02EL	5.4-5, 5.4-18	MMSZ4678T1	5.2-21, 5.2-28
MMBZ5238BLT1	5.2-21, 5.2-25	MMFT2406T1	5.1-24	MMSZ4679T1	5.2-21, 5.2-28
MMBZ5239BLT1	5.2-21, 5.2-25	MMFT2955E	5.4-14	MMSZ4680T1	5.2-21, 5.2-28
MMBZ5240BLT1	5.2-21, 5.2-25	MMFT3055E	5.4-5	MMSZ4681T1	5.2-21, 5.2-28
MMBZ5241BLT1	5.2-21, 5.2-25	MMFT3055EL	5.4-18	MMSZ4682T1	5.2-21, 5.2-28
MMBZ5242BLT1	5.2-21, 5.2-25	MMFT3055EL	5.4-5	MMSZ4683T1	5.2-21, 5.2-28
MMBZ5243BLT1	5.2-21, 5.2-25	MMFT6661T1	5.1-24	MMSZ4684T1	5.2-21, 5.2-28
MMBZ5244BLT1	5.2-21, 5.2-25	MMFT960T1	5.1-24	MMSZ4685T1	5.2-21, 5.2-28
MMBZ5245BLT1	5.2-21, 5.2-25	MMH0026	4.2-17	MMSZ4686T1	5.2-21, 5.2-28
MMBZ5246BLT1	5.2-21, 5.2-25	MMPQ2222A	5.1-9	MMSZ4687T1	5.2-21, 5.2-28
MMBZ5247BLT1	5.2-21, 5.2-25	MMPQ2369	5.1-9	MMSZ4688T1	5.2-21, 5.2-28
MMBZ5248BLT1	5.2-21, 5.2-25	MMPQ2907A	5.1-9	MMSZ4689T1	5.2-21, 5.2-28
MMBZ5249BLT1	5.2-21, 5.2-25	MMPQ3467	5.1-9	MMSZ4690T1	5.2-21, 5.2-28
MMBZ5250BLT1	5.2-21, 5.2-25	MMPQ3725	5.1-9	MMSZ4691T1	5.2-21, 5.2-28
MMBZ5251BLT1	5.2-21, 5.2-25	MMPQ3799	5.1-9	MMSZ4692T1	5.2-21, 5.2-28
MMBZ5252BLT1	5.2-21, 5.2-25	MMPQ3904	5.1-9	MMSZ4693T1	5.2-21, 5.2-28
MMBZ5253BLT1	5.2-21, 5.2-25	MMPQ3906	5.1-9	MMSZ4694T1	5.2-21, 5.2-28
MMBZ5254BLT1	5.2-21, 5.2-25	MMPQ6700	5.1-9	MMSZ4695T1	5.2-21, 5.2-28
MMBZ5255BLT1	5.2-22, 5.2-25	MMSF3P02HD	5.4-3, 5.4-14	MMSZ4696T1	5.2-21, 5.2-28
MMBZ5256BLT1	5.2-22, 5.2-25	MMSF4P01HD	5.4-3, 5.4-14	MMSZ4697T1	5.2-21, 5.2-28
MMBZ5257BLT1	5.2-22, 5.2-25	MMSF5N02HD	5.4-3, 5.4-4	MMSZ4698T1	5.2-21, 5.2-28

# Device Index

MMSZ4699T1	5.2-21, 5.2-28	MMSZ5245BT1	5.2-21, 5.2-27	MOC119S	5.8-10
MMSZ477T1	5.2-22, 5.2-30	MMSZ5246BT1	5.2-21, 5.2-27	MOC2A40-10	5.8-13
MMSZ4700T1	5.2-21, 5.2-28	MMSZ5247BT1	5.2-21, 5.2-27	MOC2A40-5	5.8-13
MMSZ4701T1	5.2-21, 5.2-28	MMSZ5248BT1	5.2-21, 5.2-27	MOC2A60-10	5.8-13
MMSZ4702T1	5.2-21, 5.2-28	MMSZ5249BT1	5.2-21, 5.2-27	MOC2A60-5	5.8-13
MMSZ4703T1	5.2-21, 5.2-28	MMSZ5250BT1	5.2-21, 5.2-27	MOC2012F	5.8-11
MMSZ4704T1	5.2-21, 5.2-28	MMSZ5251BT1	5.2-21, 5.2-27	MOC205R1	5.8-12
MMSZ4705T1	5.2-21, 5.2-28	MMSZ5252BT1	5.2-21, 5.2-27	MOC205R2	5.8-12
MMSZ4706T1	5.2-21, 5.2-28	MMSZ5253BT1	5.2-21, 5.2-27	MOC206R1	5.8-12
MMSZ4707T1	5.2-21, 5.2-28	MMSZ5254BT1	5.2-21, 5.2-27	MOC206R2	5.8-12
MMSZ4708T1	5.2-21, 5.2-28	MMSZ5255BT1	5.2-22, 5.2-27	MOC207R1	5.8-12
MMSZ4709T1	5.2-21, 5.2-28	MMSZ5256BT1	5.2-22, 5.2-27	MOC207R2	5.8-12
MMSZ4710T1	5.2-21, 5.2-28	MMSZ5257BT1	5.2-22, 5.2-27	MOC211R1	5.8-12
MMSZ4711T1	5.2-21, 5.2-28	MMSZ5258BT1	5.2-22, 5.2-27	MOC211R2	5.8-12
MMSZ4712T1	5.2-22, 5.2-28	MMSZ5259BT1	5.2-22, 5.2-27	MOC212R1	5.8-12
MMSZ4713T1	5.2-22, 5.2-28	MMSZ5260BT1	5.2-22, 5.2-27	MOC212R2	5.8-12
MMSZ4714T1	5.2-22, 5.2-28	MMSZ5261BT1	5.2-22, 5.2-27	MOC213R1	5.8-12
MMSZ4715T1	5.2-22, 5.2-28	MMSZ5262BT1	5.2-22, 5.2-27	MOC213R2	5.8-12
MMSZ4716T1	5.2-22, 5.2-28	MMSZ5263BT1	5.2-22, 5.2-27	MOC215R1	5.8-12
MMSZ4717T1	5.2-22, 5.2-28	MMSZ5264BT1	5.2-22, 5.2-27	MOC215R2	5.8-12
MMSZ5V1T1	5.2-21, 5.2-29	MMSZ5265BT1	5.2-22, 5.2-27	MOC216R1	5.8-12
MMSZ5V6T1	5.2-21, 5.2-29	MMSZ5266BT1	5.2-22, 5.2-27	MOC216R2	5.8-12
MMSZ51T1	5.2-22, 5.2-30	MMSZ5267BT1	5.2-22, 5.2-27	MOC217R1	5.8-12
MMSZ5221BT1	5.2-21, 5.2-26	MMSZ5268BT1	5.2-22, 5.2-27	MOC217R2	5.8-12
MMSZ5222BT1	5.2-21, 5.2-26	MMSZ5269BT1	5.2-22, 5.2-27	MOC221R1	5.8-12
MMSZ5223BT1	5.2-21, 5.2-26	MMSZ5270BT1	5.2-22, 5.2-27	MOC221R2	5.8-12
MMSZ5224BT1	5.2-21, 5.2-26	MMSZ5271BT1	5.2-22	MOC222R1	5.8-12
MMSZ5225BT1	5.2-21, 5.2-26	MMSZ56T1	5.2-22, 5.2-30	MOC222R2	5.8-12
MMSZ5226BT1	5.2-21, 5.2-26	MMSZ6V2T1	5.2-21, 5.2-29	MOC223R1	5.8-12
MMSZ5227BT1	5.2-21, 5.2-26	MMSZ6V8T1	5.2-21, 5.2-29	MOC223R2	5.8-12
MMSZ5228BT1	5.2-21, 5.2-26	MMSZ62T1	5.2-22, 5.2-30	MOC3009	5.7-16
MMSZ5229BT1	5.2-21, 5.2-26	MMSZ68T1	5.2-22, 5.2-30	MOC3009	5.8-8
MMSZ5230BT1	5.2-21, 5.2-26	MMSZ7V5T1	5.2-21, 5.2-29	MOC3009F	5.8-11
MMSZ5231BT1	5.2-21, 5.2-27	MMSZ75T1	5.2-22, 5.2-30	MOC3009S	5.8-11
MMSZ5232BT1	5.2-21, 5.2-27	MMSZ8V2T1	5.2-21, 5.2-29	MOC3010	5.7-16
MMSZ5233BT1	5.2-21, 5.2-27	MMSZ9V1T1	5.2-21, 5.2-29	MOC3010	5.8-8
MMSZ5234BT1	5.2-21, 5.2-27	MMUN2111LT1	5.1-12	MOC3010F	5.8-11
MMSZ5235BT1	5.2-21, 5.2-27	MMUN2112LT1	5.1-12	MOC3010S	5.8-11
MMSZ5236BT1	5.2-21, 5.2-27	MMUN2113LT1	5.1-12	MOC3011	5.7-16
MMSZ5237BT1	5.2-21, 5.2-27	MMUN2114LT1	5.1-12	MOC3011	5.8-8
MMSZ5238BT1	5.2-21, 5.2-27	MMUN2211LT1	5.1-12	MOC3011F	5.8-11
MMSZ5239BT1	5.2-21, 5.2-27	MMUN2212LT1	5.1-12	MOC3011S	5.8-11
MMSZ5240BT1	5.2-21, 5.2-27	MMUN2213LT1	5.1-12	MOC3012	5.8-8
MMSZ5241BT1	5.2-21, 5.2-27	MMUN2214LT1	5.1-12	MOC3012S	5.8-11
MMSZ5242BT1	5.2-21, 5.2-27	MM3725	5.1-19	MOC3020	5.7-16
MMSZ5243BT1	5.2-21, 5.2-27	MOC119	5.8-7	MOC3020	5.8-8
MMSZ5244BT1	5.2-21, 5.2-27	MOC119F	5.8-10	MOC3020F	5.8-11

# Device Index

MOC3020S	5.8-11	MOC3063F	5.8-11	MOC8021F	5.8-10
MOC3021	5.7-16	MOC3063FR2V	5.8-3	MOC8021S	5.8-10
MOC3021	5.8-8	MOC3063FV	5.8-3	MOC8030	5.8-7
MOC3021F	5.8-11	MOC3063S	5.8-11	MOC8030F	5.8-10
MOC3021S	5.8-11	MOC3063S	5.8-3	MOC8030S	5.8-10
MOC3022	5.8-8	MOC3063SV	5.8-3	MOC8050	5.8-7
MOC3022F	5.8-11	MOC3063TV	5.8-3	MOC8050F	5.8-10
MOC3022S	5.8-11	MOC3063V	5.8-3	MOC8050S	5.8-10
MOC3023	5.8-8	MOC3081	5.8-8	MOC8080	5.8-7
MOC3023F	5.8-11	MOC3081F	5.8-11	MOC8080F	5.8-10
MOC3023S	5.8-11	MOC3081S	5.8-11	MOC8080S	5.8-10
MOC3030	5.7-16	MOC3082	5.8-8	MOC8100	5.8-6
MOC3031	5.7-16	MOC3082F	5.8-11	MOC8100F	5.8-9
MOC3031	5.8-8	MOC3082S	5.8-11	MOC8100S	5.8-9
MOC3031F	5.8-11	MOC3083F	5.8-11	MOC8101F	5.8-10
MOC3031S	5.8-11	MOC3083S	5.8-11	MOC8101S	5.8-10
MOC3032	5.8-8	MOC3162	5.8-8	MOC8102	5.8-6
MOC3032F	5.8-11	MOC3162F	5.8-11	MOC8102F	5.8-10
MOC3032S	5.8-11	MOC3162S	5.8-11	MOC8102S	5.8-10
MOC3033	5.8-8	MOC3163	5.8-8	MOC8103	5.8-6
MOC3033F	5.8-11	MOC3163F	5.8-11	MOC8103F	5.8-10
MOC3033S	5.8-11	MOC3163S	5.8-11	MOC8103S	5.8-10
MOC3040	5.7-16	MOC5007	5.8-8	MOC8104	5.8-6
MOC3041	5.8-8	MOC5007F	5.8-12	MOC8104F	5.8-10
MOC3041F	5.8-11	MOC5007S	5.8-12	MOC8104S	5.8-10
MOC3041S	5.8-11	MOC5008	5.8-8	MOC8111	5.8-6
MOC3042	5.8-8	MOC5008F	5.8-12	MOC8111F	5.8-10
MOC3042F	5.8-11	MOC5008S	5.8-12	MOC8111S	5.8-10
MOC3042S	5.8-11	MOC5009	5.8-8	MOC8112	5.8-6
MOC3043	5.8-8	MOC5009F	5.8-11	MOC8112F	5.8-10
MOC3043F	5.8-11	MOC5009S	5.8-12	MOC8112S	5.8-10
MOC3043S	5.8-11	MOC70P1	5.8-15	MOC8113	5.8-6
MOC3051	5.8-8	MOC70P2	5.8-15	MOC8113F	5.8-10
MOC3051F	5.8-11	MOC70T1	5.8-15	MOC8113S	5.8-10
MOC3051S	5.8-11	MOC70T2	5.8-15	MOC8204	5.8-8
MOC3052	5.8-8	MOC70U1	5.8-15	MOC8204F	5.8-11
MOC3052F	5.8-11	MOC70U2	5.8-15	MOC8204S	5.8-11
MOC3052S	5.8-11	MOC70V1	5.8-15	MPC601	2.4-2
MOC3060	5.7-16	MOC70W1	5.8-15	MPC603	2.4-4
MOC3061	5.7-16	MOC71U1	5.8-15	MPF102	5.1-20
MOC3061	5.8-8	MOC71W1	5.8-15	MPF3821	5.1-20
MOC3061F	5.8-11	MOC75T1	5.8-15	MPF3822	5.1-20
MOC3061S	5.8-11	MOC75U1	5.8-15	MPF4392	5.1-21
MOC3062	5.8-8	MOC8020	5.8-7	MPF4393	5.1-21
MOC3062F	5.8-11	MOC8020F	5.8-10	MPF4856	5.1-21
MOC3062S	5.8-11	MOC8020S	5.8-10	MPF4857	5.1-21
MOC3063	5.8-8	MOC8021	5.8-7	MPF4858	5.1-21

# Device Index

MPF4859	5.1-21	MPSA13	5.1-4	MPS536	5.10-15
MPF4860	5.1-21	MPSA14	5.1-4	MPS571	5.10-15, 5.10-18
MPF4861	5.1-21	MPSA16	5.1-7	MPS6428	5.1-3
MPF6659	5.1-22	MPSA17	5.1-7	MPS650	5.1-4
MPF6660	5.1-22	MPSA18	5.1-3	MPS651	5.1-4
MPF6661	5.1-22	MPSA20	5.1-2	MPS6521	5.1-3
MPF910	5.1-22	MPSA27	5.1-4	MPS6523	5.1-3
MPF930	5.1-22	MPSA29	5.1-4	MPS6595	5.1-6
MPF960	5.1-22	MPSA42	5.1-5	MPS6602	5.1-2
MPF970	5.1-21	MPSA44	5.1-5	MPS6652	5.1-2
MPF971	5.1-21	MPSA55	5.1-2	MPS6715	5.1-4
MPF990	5.1-22	MPSA56	5.1-2	MPS6717	5.1-3
MPM3002	5.4-21	MPSA63	5.1-4	MPS6727	5.1-4
MPM3003	5.4-21	MPSA64	5.1-4	MPS750	5.1-4
MPM3004	5.4-21	MPSA70	5.1-2	MPS751	5.1-4
MPM3008	5.4-21	MPSA75	5.1-4	MPS8099	5.1-2
MPM3010	5.4-21	MPSA77	5.1-4	MPS8599	5.1-2
MPM3017	5.4-21	MPSA92	5.1-5	MPS901	5.10-15, 5.10-18
MPN3404	5.1-35	MPSH07A	5.1-6	MPS911	5.10-15, 5.10-18
MPN3700	5.1-35	MPSH10	5.1-6	MPS918	5.1-6
MPQ2222A	5.1-9	MPSH11	5.1-6	MPTE-10	5.2-6
MPQ2369	5.1-9	MPSH17	5.1-6	MPTE-10C	5.2-6
MPQ2483	5.1-9	MPSH20	5.1-6	MPTE-12	5.2-6
MPQ2484	5.1-9	MPSH24	5.1-6	MPTE-12C	5.2-6
MPQ2907A	5.1-9	MPSH69	5.1-6	MPTE-15	5.2-6
MPQ3467	5.1-9	MPSH81	5.1-6	MPTE-15C	5.2-6
MPQ3725	5.1-9	MPSW01A	5.1-4	MPTE-18	5.2-6
MPQ3762	5.1-9	MPSW06	5.1-3	MPTE-18C	5.2-6
MPQ3798	5.1-9	MPSW42	5.1-5	MPTE-22	5.2-6
MPQ3799	5.1-9	MPSW45A	5.1-4	MPTE-22C	5.2-6
MPQ3904	5.1-9	MPSW51A	5.1-4	MPTE-36	5.2-6
MPQ3906	5.1-9	MPSW56	5.1-3	MPTE-36C	5.2-6
MPQ6001	5.1-9	MPSW64	5.1-4	MPTE-45	5.2-6
MPQ6002	5.1-9	MPSW92	5.1-5	MPTE-45C	5.2-6
MPQ6100A	5.1-9	MPS2222A	5.1-2	MPTE-5	5.2-6
MPQ6426	5.1-9	MPS2369A	5.1-6	MPTE-8	5.2-6
MPQ6501	5.1-9	MPS2907A	5.1-2	MPTE-8C	5.2-6
MPQ6502	5.1-9	MPS3563	5.1-6	MPX10D	5.9-4, 5.9-8
MPQ6600A1	5.1-9	MPS3646	5.1-6	MPX10DP	5.9-8
MPQ6700	5.1-9	MPS3866	5.10-15, 5.10-19	MPX10GP	5.9-8
MPQ6842	5.1-9	MPS3866	5.1-6	MPX10GS	5.9-8
MPQ7042	5.1-9	MPS3904	5.1-3	MPX10GSX	5.9-8
MPQ7043	5.1-9	MPS3906	5.1-3	MPX10GVP	5.9-8
MPQ7051	5.1-9	MPS404A	5.1-7	MPX10GVS	5.9-8
MPQ7093	5.1-9	MPS4250	5.1-3	MPX10GVSX	5.9-8
MPSA05	5.1-2	MPS4258	5.1-6	MPX100A	5.9-4, 5.9-8
MPSA06	5.1-2	MPS5179	5.1-6	MPX100AP	5.9-8

# Device Index

MPX100AS	5.9-8	MPX2052GVS	5.9-9	MPX50GVS	5.9-8
MPX100ASX	5.9-8	MPX2052GVSX	5.9-9	MPX50GVSX	5.9-8
MPX100D	5.9-4, 5.9-8	MPX2100A	5.9-4, 5.9-9	MPX5050D	5.9-4, 5.9-10
MPX100DP	5.9-8	MPX2100AS	5.9-9	MPX5050DP	5.9-10
MPX100GP	5.9-8	MPX2100ASX	5.9-9	MPX5050GP	5.9-10
MPX100GS	5.9-8	MPX2100D	5.9-4, 5.9-9	MPX5050GS	5.9-10
MPX100GSX	5.9-8	MPX2100DP	5.9-9	MPX5050GSX	5.9-10
MPX100GVP	5.9-8	MPX2100GP	5.9-9	MPX5050GVP	5.9-10
MPX100GVS	5.9-8	MPX2100GS	5.9-9	MPX5050GVS	5.9-10
MPX100GVSX	5.9-8	MPX2100GSX	5.9-9	MPX5050GVSX	5.9-10
MPX12D	5.9-4	MPX2100GVP	5.9-9	MPX5100A	5.9-4, 5.9-10
MPX200A	5.9-4, 5.9-8	MPX2100GVS	5.9-9	MPX5100AP	5.9-10
MPX200AP	5.9-8	MPX2100GVSX	5.9-9	MPX5100AS	5.9-10
MPX200AS	5.9-8	MPX2200A	5.9-4, 5.9-9	MPX5100ASX	5.9-10
MPX200ASX	5.9-8	MPX2200AS	5.9-9	MPX5100D	5.9-4, 5.9-10
MPX200D	5.9-4, 5.9-8	MPX2200ASX	5.9-9	MPX5100DP	5.9-10
MPX200DP	5.9-8	MPX2200D	5.9-4, 5.9-9	MPX5100GP	5.9-10
MPX200GP	5.9-8	MPX2200DP	5.9-9	MPX5100GS	5.9-10
MPX200GS	5.9-8	MPX2200GP	5.9-9	MPX5100GSX	5.9-10
MPX200GSX	5.9-8	MPX2200GS	5.9-9	MPX5100GVP	5.9-10
MPX200GVP	5.9-8	MPX2200GSX	5.9-9	MPX5100GVS	5.9-10
MPX200GVS	5.9-8	MPX2200GVP	5.9-9	MPX5100GVSX	5.9-10
MPX200GVSX	5.9-8	MPX2200GVS	5.9-9	MPX700A	5.9-8
MPX201A	5.9-4	MPX2200GVSX	5.9-9	MPX700AP	5.9-8
MPX201D	5.9-4	MPX2700D	5.9-4	MPX700AS	5.9-8
MPX2010D	5.9-4, 5.9-9	MPX4100A	5.9-4, 5.9-10	MPX700ASX	5.9-8
MPX2010DP	5.9-9	MPX4100AP	5.9-10	MPX700D	5.9-4, 5.9-8
MPX2010GP	5.9-9	MPX4100AS	5.9-10	MPX700DP	5.9-8
MPX2010GS	5.9-9	MPX4100ASX	5.9-10	MPX700GP	5.9-8
MPX2010GSX	5.9-9	MPX4101A	5.9-4, 5.9-10	MPX700GS	5.9-8
MPX2010GVP	5.9-9	MPX4101AP	5.9-10	MPX700GSX	5.9-8
MPX2010GVS	5.9-9	MPX4101AS	5.9-10	MPX700GVP	5.9-8
MPX2010GVSX	5.9-9	MPX4101ASX	5.9-10	MPX700GVS	5.9-8
MPX2050D	5.9-4, 5.9-9	MPX4115A	5.9-4, 5.9-10	MPX700GVSX	5.9-8
MPX2050DP	5.9-9	MPX4115AP	5.9-10	MPX7050D	5.9-4, 5.9-10
MPX2050GP	5.9-9	MPX4115AS	5.9-10	MPX7050DP	5.9-10
MPX2050GS	5.9-9	MPX4115ASX	5.9-10	MPX7050GP	5.9-10
MPX2050GSX	5.9-9	MPX4250A	5.9-4, 5.9-10	MPX7050GS	5.9-10
MPX2050GVP	5.9-9	MPX4250AP	5.9-10	MPX7050GSX	5.9-10
MPX2050GVS	5.9-9	MPX4250AS	5.9-10	MPX7050GVP	5.9-10
MPX2050GVSX	5.9-9	MPX4250ASX	5.9-10	MPX7050GVS	5.9-10
MPX2052D	5.9-4, 5.9-9	MPX50D	5.9-4, 5.9-8	MPX7050GVSX	5.9-10
MPX2052DP	5.9-9	MPX50DP	5.9-8	MPX7100A	5.9-4, 5.9-10
MPX2052GP	5.9-9	MPX50GP	5.9-8	MPX7100AP	5.9-10
MPX2052GS	5.9-9	MPX50GS	5.9-8	MPX7100AS	5.9-10
MPX2052GSX	5.9-9	MPX50GSX	5.9-8	MPX7100ASX	5.9-10
MPX2052GVP	5.9-9	MPX50GVP	5.9-8	MPX7100D	5.9-4, 5.9-10

8

# Device Index

MPX7100DP	5.9-10	MRA1000-7L	5.10-12	MRF10150HX	6.3-17
MPX7100GP	5.9-10	MRA1417-6	5.10-11	MRF1029	5.10-12
MPX7100GS	5.9-10	MRD300	5.8-14	MRF1030	5.10-12
MPX7100GSX	5.9-10	MRD3050	5.8-14	MRF1031	5.10-12
MPX7100GVP	5.9-10	MRD3056	5.8-14	MRF1032	5.10-12
MPX7100GVS	5.9-10	MRD310	5.8-14	MRF1035MA	5.10-10
MPX7100GVSX	5.9-10	MRD360	5.8-14	MRF1035MB	5.10-10
MPX7200A	5.9-4, 5.9-10	MRD370	5.8-14	MRF10350	5.10-11
MPX7200AP	5.9-10	MRD500	5.8-14	MRF10350HX	6.3-17
MPX7200AS	5.9-10	MRD5009	5.8-14	MRF10500	5.10-11
MPX7200ASX	5.9-10	MRD510	5.8-14	MRF10500HX	6.3-17
MPX7200D	5.9-4, 5.9-10	MRD821	5.8-14	MRF1090MA	5.10-10
MPX7200DP	5.9-10	MRD901	5.8-14	MRF1090MB	5.10-10
MPX7200GP	5.9-10	MRD911	5.8-14	MRF1150MA	5.10-10
MPX7200GS	5.9-10	MRD921	5.8-14	MRF1150MB	5.10-10
MPX7200GSX	5.9-10	MRD950	5.8-14	MRF134	5.10-4
MPX7200GVP	5.9-10	MRFA2600	5.10-26	MRF136	5.10-4
MPX7200GVS	5.9-10	MRFA2602	5.10-26	MRF136Y	5.10-4
MPX7200GVSX	5.9-10	MRFIC1801	5.10-22	MRF137	5.10-4
MQ2369A	6.3-5	MRFIC1803	5.10-22	MRF1375	5.10-11
MQ2369AHXV	6.3-17	MRFIC1804	5.10-22	MRF138	5.10-4
MQ2369AHXV	6.3-16	MRFIC2001	5.10-21	MRF140	5.10-4
MQ2484	6.3-5	MRFIC2002	5.10-21	MRF141	5.10-4
MQ2484HXV	6.3-17	MRFIC2003	5.10-21	MRF141G	5.10-4
MQ2484HXV	6.3-16	MRFIC2004	5.10-21	MRF148	5.10-4
MQ2605	6.3-5	MRFIC2006	5.10-21	MRF150	5.10-4
MQ2605HXV	6.3-17	MRFIC2101	5.10-21	MRF1500	5.10-11
MQ3251A	6.3-5	MRFIC2101	5.10-21	MRF15030	5.10-10
MQ3251AHXV	6.3-17	MRFQ17	5.10-17, 5.10-19	MRF15090	5.10-10
MQ3251AHXV	6.3-16	MRF0211LT1	5.10-17, 5.10-18	MRF151	5.10-4
MQ3468	6.3-5	MRF1000MA	5.10-10	MRF151G	5.10-4
MQ3468HXV	6.3-17	MRF1000MB	5.10-10	MRF154	5.10-4
MQ3468HXV	6.3-16	MRF10005	5.10-10	MRF157	5.10-4
MQ6002	6.3-5	MRF10005HX	6.3-17	MRF158	5.10-5
MQ6002	6.3-5	MRF1002MA	5.10-10	MRF158R	5.10-5
MQ6002HXV	6.3-17	MRF1002MB	5.10-10	MRF161	5.10-5
MQ6002HXV	6.3-16	MRF10031	5.10-10	MRF162	5.10-5
MQ918	6.3-5	MRF10031HX	6.3-17	MRF163	5.10-5
MQ918HXV	6.3-17	MRF1004MA	5.10-10	MRF164W	5.10-5
MQ918HXV	6.3-16	MRF1004MB	5.10-10	MRF166	5.10-4
MRAL1720-20	5.10-11	MRF10070	5.10-11	MRF166C	5.10-5
MRAL2023-18	5.10-11	MRF10070HX	6.3-17	MRF171	5.10-4
MRAL2023-3	5.10-11	MRF10120	5.10-10	MRF173	5.10-4
MRAL2023-6	5.10-11	MRF10120HX	6.3-17	MRF173CQ	5.10-4
MRAL2327-12	5.10-11	MRF1015MA	5.10-10	MRF174	5.10-4
MRAL2327-3	5.10-11	MRF1015MB	5.10-10	MRF175GU	5.10-5
MRA1000-14L	5.10-12	MRF10150	5.10-11	MRF175GV	5.10-4

# Device Index

MRF175LU	5.10-5	MRF454	5.10-6	MRF6603HX	6.3-15
MRF175LV	5.10-4	MRF455	5.10-6	MRF6603HXV	6.3-17
MRF176GU	5.10-5	MRF464	5.10-6	MRF6603HXV	6.3-15
MRF176GV	5.10-4	MRF492	5.10-6	MRF6604	6.3-5
MRF177	5.10-5	MRF4957	6.3-5	MRF6604AHXV	6.3-17
MRF177M	5.10-5	MRF4957HX	6.3-15	MRF6604HXV	6.3-15
MRF182	5.10-5	MRF4957HXV	6.3-15	MRF837	5.10-8, 5.10-16
MRF183	5.10-5	MRF5003	5.10-5	MRF8372	5.10-17
MRF1946	5.10-7	MRF5015	5.10-5	MRF8372	5.10-8
MRF1946A	5.10-7	MRF5035	5.10-5	MRF839F	5.10-8
MRF2000-5L	5.10-12	MRF5109	6.3-5	MRF840	5.10-8
MRF224	5.10-7	MRF5109HX	6.3-15	MRF842	5.10-8
MRF240	5.10-7	MRF5109HXV	6.3-15	MRF844	5.10-8
MRF247	5.10-7	MRF521	5.10-16, 5.10-18	MRF847	5.10-8
MRF2628	5.10-7	MRF5211LT1	5.10-17, 5.10-18	MRF857	5.10-9
MRF2857	6.3-5	MRF522	6.3-5	MRF857S	5.10-9
MRF2857HX	6.3-15	MRF522HXV	6.3-15, 6.3-17	MRF858	5.10-9
MRF2857HXV	6.3-15	MRF553	5.10-7, 5.10-16	MRF860	5.10-9
MRF3094	5.10-12	MRF555	5.10-8, 5.10-16	MRF861	5.10-9
MRF3095	5.10-12	MRF557	5.10-8, 5.10-16	MRF862	5.10-9
MRF3096	5.10-12	MRF5583	6.3-5	MRF880	5.10-9
MRF3104	5.10-12	MRF5583	5.10-17, 5.10-19	MRF890	5.10-9
MRF3105	5.10-12	MRF5583HX	6.3-15	MRF890S	5.10-9
MRF3106	5.10-12	MRF5583HXV	6.3-15	MRF891	5.10-9
MRF313	5.10-7	MRF559	5.10-8, 5.10-16	MRF891S	5.10-9
MRF314	5.10-6	MRF571	5.10-16, 5.10-18	MRF892	5.10-9
MRF315	5.10-6	MRF5711LT1	5.10-17, 5.10-18	MRF894	5.10-9
MRF316	5.10-6	MRF581	5.10-8, 5.10-16	MRF896	5.10-9
MRF317	5.10-6		5.10-18, 5.10-19	MRF896S	5.10-9
MRF321	5.10-7	MRF581A	5.10-16, 5.10-19	MRF897	5.10-9
MRF323	5.10-7	MRF5812	5.10-17, 5.10-18	MRF898	5.10-9
MRF325	5.10-7		5.10-19	MRF899	5.10-9
MRF326	5.10-7	MRF587	5.10-17, 5.10-19	MRF901	5.10-18
MRF327	5.10-7	MRF5943	5.10-17, 5.10-19	MRF901	5.10-16
MRF329	5.10-7	MRF6401	5.10-13	MRF9011LT1	5.10-17, 5.10-18
MRF3866	5.10-17, 5.10-19	MRF6402	5.10-13	MRF904X/NBP	6.4-31
MRF3866A	6.3-5	MRF6404	5.10-13	MRF914X/NBP	6.4-31
MRF3866AHX	6.3-15	MRF641	5.10-8	MRF9331LT1	5.10-17
MRF3866HXV	6.3-15	MRF644	5.10-8	MRF941	5.10-16, 5.10-18
MRF392	5.10-7	MRF650	5.10-8	MRF9411BLT1	5.10-17
MRF393	5.10-7	MRF652	5.10-8	MRF9411LT1	5.10-17, 5.10-18
MRF421	5.10-6	MRF652S	5.10-8	MRF947BT1	5.10-17, 5.10-18
MRF422	5.10-6	MRF653	5.10-8	MRF947T1	5.10-17, 5.10-18
MRF426	5.10-6	MRF653S	5.10-8	MRF951	5.10-16, 5.10-18
MRF429	5.10-6	MRF654	5.10-8	MRF9511LT1	5.10-17, 5.10-18
MRF4427	5.10-7, 5.10-17	MRF658	5.10-8	MRF957T1	5.10-17, 5.10-18
MRF448	5.10-6	MRF6603	6.3-5	MRW2001	5.10-11

# Device Index

MRW2003	5.10-11	MTA2955E	5.4-16	MTD20P06HDL	5.4-3, 5.4-15
MRW2005	5.10-11	MTA30N06E	5.4-10		5.4-18, 5.4-20
MRW2010	5.10-11	MTA3055E	5.4-10	MTD2955E	5.4-15
MRW3001	5.10-11	MTA4N40E	5.4-10	MTD3N25E	5.4-6
MRW3003	5.10-11	MTA4N50E	5.4-10	MTD3055E	5.4-6
MRW3005	5.10-11	MTA4N60E	5.4-10	MTD3055EL	5.4-6, 5.4-18, 5.4-20
MRW52602	5.10-13	MTA5N50E	5.4-10	MTD4N20	5.4-6
MRW52604	5.10-13	MTA6N40E	5.4-10	MTD4N20E	5.4-6
MRW53502	5.10-13	MTA8N10E	5.4-10	MTD5N25E	5.4-6
MRW53601	5.10-13	MTB1N100E	5.4-7	MTD5P06E	5.4-15
MRW54001	5.10-13	MTB10N40E	5.4-7	MTD6N10E	5.4-6
MRW54601	5.10-13	MTB15N06E	5.4-7	MTD6N15	5.4-6
MR10120E	5.6-3, 5.6-12	MTB2P50E	5.4-15	MTD6P10E	5.4-15
	5.6-14	MTB20N20E	5.4-7	MTD8N06E	5.4-6
MR10120E	5.5-20	MTB23P06E	5.4-15	MTD9N10E	5.4-6
MR10150E	5.6-3, 5.6-12	MTB3N100E	5.4-7	MTE125N20E	5.4-22
	5.6-14	MTB3N120E	5.4-7	MTE215N10E	5.4-22
MR10150E	5.5-20	MTB30N06EL	5.4-7	MTE53N50E	5.4-22
MR2504	5.6-14		and 5.4-19	MTM12P10	5.4-17
MR2510	5.6-14	MTB33N10E	5.4-7	MTM15N40E	5.4-13
MR2535L	5.6-3, 5.6-14	MTB36N06E	5.4-7	MTP1N100E	5.4-8
MR2535L	5.2-15	MTB4N80E	5.4-7	MTP1N50E	5.4-8
MR4422CT	5.6-14	MTB50N06E	5.4-7	MTP1N60E	5.4-8
MR4422CTR	5.6-14	MTB50N06EL	5.4-7, 5.4-19	MTP10N10E	5.4-9
MR754	5.6-14		5.4-20	MTP10N15	5.4-9
MR760	5.6-14	MTB50P03HDL	5.4-3, 5.4-15	MTP10N40E	5.4-8
MR852	5.6-14		5.4-19, 5.4-20	MTP12N10E	5.4-9
MR856	5.6-14	MTB6N60E	5.4-7	MTP12N20	5.4-9
MSA1022-BT1	5.1-13	MTB60N06HD	5.4-3, 5.4-7	MTP12P06	5.4-16
MSA1022-CT1	5.1-13	MTB75N03HDL	5.4-3, 5.4-7	MTP12P10	5.4-16
MSB1218A-RT1	5.1-11		5.4-19, 5.4-20	MTP13P06V	5.4-24
MSB709-RT1	5.1-11	MTB75N05HD	5.4-3, 5.4-7	MTP15N05E	5.4-9
MSB709-ST1	5.1-11	MTB75N06HD	5.4-3, 5.4-7	MTP15N05EL	5.4-20
MSB710-QT1	5.1-11	MTB8N50E	5.4-7	MTP15N06E	5.4-9
MSB710-RT1	5.1-11	MTD1N50E	5.4-6	MTP15N06V	5.4-24
MSC1621T1	5.1-12	MTD1N60E	5.4-6	MTP15N15	5.4-9
MSC2295-BT1	5.1-13	MTD1N80E	5.4-6	MTP16P06V	5.4-24
MSC2295-CT1	5.1-13	MTD10N05E	5.4-6	MTP2N20	5.4-8
MSC2404-CT1	5.1-13	MTD2N40E	5.4-6	MTP2N40E	5.4-8
MSC3130T1	5.1-13	MTD2N50E	5.4-6	MTP2N50E	5.4-8
MSD1328-RT1	5.1-11	MTD20N03HDL	5.4-3, 5.4-6	MTP2N60E	5.4-8
MSD1819A-RT1	5.1-11		5.4-18, 5.4-20	MTP2P50E	5.4-16
MSD601-RT1	5.1-11	MTD20N06HD	5.4-3, 5.4-6	MTP20N06	5.4-9
MSD601-ST1	5.1-11	MTD20N06HDL	5.4-3, 5.4-6	MTP20N06V	5.4-24
MSD602-RT1	5.1-11		5.4-18, 5.4-20	MTP20N20E	5.4-9
MTA1N60E	5.4-10	MTD20P03HDL	5.4-3, 5.4-15	MTP23P06	5.4-16
MTA2N60E	5.4-10		5.4-20	MTP25N06V	5.4-24



# Device Index

MTP25P06V	5.4-24	MTW14P20	5.4-17	MURF10150E	5.6-12
MTP2955E	5.4-16	MTW15N25E	5.4-11	MURF1620CT	5.6-12
MTP2955V	5.4-24	MTW16N40E	5.4-11	MURF1660CT	5.6-12
MTP3N100E	5.4-8	MTW20N20E	5.4-11	MURF820	5.6-12
MTP3N120E	5.4-8	MTW20N50E	5.4-11	MURHB840CT	5.6-11
MTP3N25E	5.4-8	MTW20P10	5.4-17	MURH840CT	5.6-3, 5.6-12
MTP3N50E	5.4-8	MTW23N25E	5.4-11	MURH860CT	5.6-3, 5.6-12
MTP3N60E	5.4-8	MTW24N40E	5.4-11	MURP20020CT	5.6-13
MTP30N06EL	5.4-20	MTW26N15E	5.4-11	MURP20040CT	5.6-13
MTP30P06V	5.4-24	MTW32N20E	5.4-11	MURS120T3	5.6-11
MTP3055E	5.4-9	MTW32N25E	5.4-11	MURS160T3	5.6-11
MTP3055EL	5.4-20	MTW33N10E	5.4-11	MURS320T3	5.6-11
MTP3055V	5.4-24	MTW35N15E	5.4-11	MURS360T3	5.6-11
MTP33N10E	5.4-9	MTW4N80E	5.4-11	MUR10120E	5.6-3, 5.6-12
MTP36N06E	5.4-9	MTW45N10E	5.4-11	MUR10120E	5.5-20
MTP36N06V	5.4-24	MTW54N05E	5.4-11	MUR10150E	5.6-3, 5.6-12
MTP4N40E	5.4-8	MTW6N100E	5.4-11	MUR10150E	5.5-20
MTP4N50E	5.4-8	MTW6N60E	5.4-11	MUR1100E	5.6-11
MTP4N80E	5.4-8	MTW7N80E	5.4-11	MUR120	5.6-11
MTP5N40E	5.4-8	MTW8N50E	5.4-11	MUR140	5.6-11
MTP5P25	5.4-16	MTW8N60E	5.4-11	MUR1520	5.6-12
MTP50N05E	5.4-9	MTY10N100E	5.4-12	MUR1540	5.6-12
MTP50N06E	5.4-9	MTY100N10E	5.4-12	MUR1560	5.6-12
MTP50N06EL	5.4-20	MTY25N60E	5.4-12	MUR160	5.6-11
MTP50N06V	5.4-24	MTY30N50E	5.4-12	MUR1620CT	5.6-12
MTP50P03HDL	5.4-3, 5.4-16 5.4-19, 5.4-20	MTY55N20E	5.4-12	MUR1620CTR	5.6-12
MTP6N10	5.4-9	MUN2111T1	5.1-11	MUR1640CT	5.6-12
MTP6N60E	5.4-8	MUN2112T1	5.1-11	MUR1660CT	5.6-12
MTP6P20E	5.4-16	MUN2113T1	5.1-11	MUR3020PT	5.6-13
MTP60N06HD	5.4-3, 5.4-9	MUN2114T1	5.1-11	MUR3020WT	5.6-13
MTP7N20	5.4-8	MUN2211T1	5.1-11	MUR3040	5.6-13
MTP7P06	5.4-16	MUN2212T1	5.1-11	MUR3040PT	5.6-13
MTP7P06V	5.4-24	MUN2213T1	5.1-11	MUR3040WT	5.6-13
MTP75N03HDL	5.4-3, 5.4-9 5.4-19, 5.4-20	MUN2214T1	5.1-11	MUR3060	5.6-13
MTP75N05HD	5.4-3, 5.4-9	MUN5111T1	5.1-12	MUR3060PT	5.6-13
MTP75N06HD	5.4-3, 5.4-9	MUN5112T1	5.1-12	MUR3060WT	5.6-13
MTP8N20	5.4-9	MUN5113T1	5.1-12	MUR3080	5.6-13
MTP8N50E	5.4-8	MUN5114T1	5.1-12	MUR4100E	5.6-11
MTP8P10	5.4-16	MUN5211T1	5.1-12	MUR420	5.6-11
MTP8P20	5.4-16	MUN5212T1	5.1-12	MUR440	5.6-11
MTS102	5.9-4	MUN5213T1	5.1-12	MUR460	5.6-11
MTS105	5.9-4	MUN5214T1	5.1-12	MUR5150E	5.6-3, 5.6-12
MTW10N100E	5.4-11	MURB1620CT	5.6-11	MUR5150E	5.5-20
MTW10N40E	5.4-11	MURB1660CT	5.6-11	MUR6040	5.6-13
MTW14N50E	5.4-11	MURD320	5.6-11	MUR620CT	5.6-12
		MURD620CT	5.6-11	MUR8100E	5.6-12
		MURF10120E	5.6-12	MUR8100E	5.5-20

# Device Index

MUR820	5.6-12	MZC120A5HV	6.3-22	MZC7.5A5HV	6.3-22
MUR840	5.6-12	MZC13A5HV	6.3-22	MZC75A5H	6.3-22
MUR860	5.6-12	MZC130A5HV	6.3-22	MZC8.2A5HV	6.3-22
MUR860E	5.5-20	MZC14A5HV	6.3-22	MZC8.7AHV	6.3-22
MUR880E	5.6-3, 5.6-12	MZC140A5HV	6.3-22	MZC82A5HV	6.3-22
MVAM108	5.1-32	MZC15A5HV	6.3-22	MZC87A5HV	6.3-22
MVAM109	5.1-32	MZC150A5HB	6.3-22	MZC9.1A5HV	6.3-22
MVAM115	5.1-32	MZC16A5HV	6.3-22	MZC91A5HV	6.3-22
MVAM125	5.1-32	MZC160A5HV	6.3-22	MZD10RL	5.2-18
MV104	5.1-28	MZC17A5HV	6.3-22	MZD100	5.2-19
MV1403	5.1-32	MZC170A5HV	6.3-22	MZD11RL	5.2-18
MV1404	5.1-32	MZC18A5HV	6.3-22	MZD110	5.2-19
MV1404X/NBP	6.4-32	MZC180A5HV	6.3-22	MZD12RL	5.2-18
MV1405	5.1-32	MZC19A5HV	6.3-22	MZD120	5.2-19
MV1620	5.1-27	MZC190A5HV	6.3-22	MZD13RL	5.2-18
MV1624	5.1-27	MZC2.4A5HV	6.3-22	MZD130	5.2-19
MV1626	5.1-27	MZC2.5A5HV	6.3-22	MZD15RL	5.2-18
MV1628	5.1-27	MZC2.7A5HV	6.3-22	MZD150	5.2-19
MV1630	5.1-27	MZC2.8A5HV	6.3-22	MZD16RL	5.2-18
MV1634	5.1-27	MZC20A5HV	6.3-22	MZD160	5.2-19
MV1636	5.1-27	MZC200A5HV	6.3-22	MZD18RL	5.2-18
MV1638	5.1-27	MZC22A5HV	6.3-22	MZD180	5.2-19
MV1640	5.1-27	MZC24A5HV	6.3-22	MZD20RL	5.2-18
MV1642	5.1-27	MZC25A5HV	6.3-22	MZD200	5.2-19
MV1644	5.1-27	MZC27A5HV	6.3-22	MZD22RL	5.2-18
MV1648	5.1-27	MZC28A5HV	6.3-22	MZD24RL	5.2-18
MV1650	5.1-27	MZC3.0A5HV	6.3-22	MZD27RL	5.2-18
MV209	5.1-31	MZC3.3A5HV	6.3-22	MZD3.9RL	5.2-18
MV2101	5.1-27	MZC3.9A5HV	6.3-22	MZD30RL	5.2-18
MV2103	5.1-27	MZC30A5HV	6.3-22	MZD33RL	5.2-18
MV2104	5.1-27	MZC33A5HV	6.3-22	MZD36RL	5.2-18
MV2105	5.1-27	MZC36A5HV	6.3-22	MZD39RL	5.2-18
MV2107	5.1-27	MZC39A5HV	6.3-22	MZD4.3RL	5.2-18
MV2108	5.1-27	MZC4.3A5HV	6.3-22	MZD4.7RL	5.2-18
MV2109	5.1-27	MZC4.7A5HV	6.3-22	MZD43RL	5.2-18
MV2111	5.1-27	MZC43A5HV	6.3-22	MZD47RL	5.2-18
MV2113	5.1-27	MZC47A5HV	6.3-22	MZD5.1RL	5.2-18
MV2114	5.1-27	MZC5.1A5HCV	6.3-22	MZD5.6RL	5.2-18
MV2115	5.1-27	MZC5.6A5HV	6.3-22	MZD51	5.2-18
MV409	5.1-31	MZC51A5HV	6.3-22	MZD56	5.2-18
MV7005T1	5.1-32	MZC56A5HV	6.3-22	MZD6.2RL	5.2-18
MV7404T1	5.1-32	MZC6.0A5HV	6.3-22	MZD6.8RL	5.2-18
MZC100A5HV	6.3-22	MZC6.2A5HV	6.3-22	MZD62	5.2-18
MZC10A5HV	6.3-22	MZC6.8A5HV	6.3-22	MZD68	5.2-18
MZC11A5HV	6.3-22	MZC60A5HV	6.3-22	MZD7.5RL	5.2-18
MZC110A5HV	6.3-22	MZC62A5HV	6.3-22	MZD75	5.2-19
MZC12A5HV	6.3-22	MZC68A5HV	6.3-22	MZD8.2RL	5.2-18

# Device Index

MZD82	5.2-19	MZP4737A	5.2-18	MZ4627	5.2-16
MZD9.1RL	5.2-18	MZP4738A	5.2-18	MZ5520B	5.2-16
MZD91	5.2-19	MZP4739A	5.2-18	MZ5521B	5.2-16
MZPY10RL	5.2-18	MZP4740A	5.2-18	MZ5522B	5.2-16
MZPY100RL	5.2-19	MZP4741A	5.2-18	MZ5523B	5.2-16
MZPY11RL	5.2-18	MZP4742A	5.2-18	MZ5524B	5.2-16
MZPY12RL	5.2-18	MZP4743A	5.2-18	MZ5525B	5.2-16
MZPY13RL	5.2-18	MZP4744A	5.2-18	MZ5526B	5.2-16
MZPY15RL	5.2-18	MZP4745A	5.2-18	MZ5527B	5.2-16
MZPY16RL	5.2-18	MZP4746A	5.2-18	MZ5528B	5.2-16
MZPY18RL	5.2-18	MZP4747A	5.2-18	MZ5529B	5.2-16
MZPY20RL	5.2-18	MZP4748A	5.2-18	MZ5530B	5.2-16
MZPY22RL	5.2-18	MZP4749A	5.2-18	M1MA141KT1	5.1-35
MZPY24RL	5.2-18	MZP4750A	5.2-18	M1MA141WAT1	5.1-36
MZPY27RL	5.2-18	MZP4751A	5.2-18	M1MA141WKT1	5.1-36
MZPY3.9RL	5.2-18	MZP4752A	5.2-18	M1MA142KT1	5.1-35
MZPY30RL	5.2-18	MZP4753A	5.2-18	M1MA142WAT1	5.1-36
MZPY33RL	5.2-18	MZP4754A	5.2-18	M1MA142WKT1	5.1-36
MZPY36RL	5.2-18	MZP4755A	5.2-18	M1MA151AT1	5.1-35
MZPY39RL	5.2-18	MZP4756A	5.2-18	M1MA151KT1	5.1-35
MZPY4.3RL	5.2-18	MZP4757A	5.2-18	M1MA151WAT1	5.1-36
MZPY4.7RL	5.2-18	MZP4758A	5.2-18	M1MA151WKT1	5.1-36
MZPY43RL	5.2-18	MZP4759A	5.2-18	M143120EVBU	2.6-7
MZPY47RL	5.2-18	MZP4760A	5.2-18	M143150EVBU	2.6-7
MZPY5.1RL	5.2-18	MZP4761A	5.2-19	M143204EVK	2.6-7
MZPY5.6RL	5.2-18	MZP4762A	5.2-19	M143205EVK	2.6-7
MZPY51RL	5.2-18	MZP4763A	5.2-19	M143206EVK	2.6-7
MZPY56RL	5.2-18	MZP4764A	5.2-19	M143207EVK	2.6-7
MZPY6.2RL	5.2-18	MZ4099	5.2-16	M143208EVK	2.6-7
MZPY6.8RL	5.2-18	MZ4100	5.2-16	M44000	4.8-15
MZPY62RL	5.2-18	MZ4101	5.2-16	M68HC05BPGMR	2.5-40
MZPY68RL	5.2-18	MZ4102	5.2-16	M68HC05C5EVS	2.5-40
MZPY7.5RL	5.2-18	MZ4103	5.2-16	M68HC05C9EVS	2.5-40
MZPY75RL	5.2-19	MZ4104	5.2-16	M68HC05D32EVS	2.5-40
MZPY8.2RL	5.2-18	MZ4614	5.2-16	M68HC05E1EVS	2.5-40
MZPY82RL	5.2-19	MZ4615	5.2-16	M68HC05F6EVM	2.5-40
MZPY9.1RL	5.2-18	MZ4616	5.2-16	M68HC05F8EVM	2.5-40
MZPY91RL	5.2-19	MZ4617	5.2-16	M68HC05G1EVM	2.5-40
MZP4728A	5.2-18	MZ4618	5.2-16	M68HC05G10EVM	2.5-40
MZP4729A	5.2-18	MZ4619	5.2-16	M68HC05G9EVM	2.5-40
MZP4730A	5.2-18	MZ4620	5.2-16	M68HC05H2EVS	2.5-40
MZP4731A	5.2-18	MZ4621	5.2-16	M68HC05I8EVS	2.5-40
MZP4732A	5.2-18	MZ4622	5.2-16	M68HC05J3EVS	2.5-40
MZP4733A	5.2-18	MZ4623	5.2-16	M68HC05L1EVM	2.5-41
MZP4734A	5.2-18	MZ4624	5.2-16	M68HC05L10EVM	2.5-41
MZP4735A	5.2-18	MZ4625	5.2-16	M68HC05L11EVM	2.5-41
MZP4736A	5.2-18	MZ4626	5.2-16	M68HC05L2EVS	2.5-41

8

# Device Index

M68HC05L4EVS	2.5-41	PBF259S	5.1-7	P6KE150CA	5.2-5, 5.2-12
M68HC05L5EVS	2.5-41	PBF493	5.1-7	P6KE16A	5.2-4, 5.2-12
M68HC05L9EVM2	2.5-41	PBF493S	4.1-7	P6KE16CA	5.2-4, 5.2-12
M68HC05M4EVM	2.5-41	PC68F333	2.5-38	P6KE160A	5.2-5, 5.2-12
M68HC05PGMR-2	2.5-40	PC68HC11G0	2.5-24	P6KE160CA	5.2-5, 5.2-12
M68HC05P3EVS	2.5-41	PC68HC11G5	2.5-24	P6KE170A	5.2-5, 5.2-12
M68HC05P8EVS	2.5-41	PC68HC11G7	2.5-24	P6KE170CA	5.2-5, 5.2-12
M68HC05P8EVS	2.5-40	PC68HC11J6	2.5-24	P6KE18A	5.2-4, 5.2-12
M68HC05P9EVS	2.5-41	PC68HC711D3	2.5-25	P6KE18CA	5.2-4, 5.2-12
M68HC05SCEVS	2.5-41	PC68HC711E20	2.5-25	P6KE180A	5.2-5, 5.2-12
M68HC05T12EVM	2.5-41	PC68HC711E9	2.5-25	P6KE180CA	5.2-5, 5.2-12
M68HC05T2EVS	2.5-41	PC68HC711G5	2.5-25	P6KE20A	5.2-4, 5.2-12
M68HC05T4EVM	2.5-41	PC68HC711J6	2.5-25	P6KE20CA	5.2-4, 5.2-12
M68HC05T7EVM	2.5-41	PC68HC711K4	2.5-25	P6KE200A	5.2-5, 5.2-12
M68HC05X16EVS	2.5-41	PC68HC711L6	2.5-25	P6KE200CA	5.2-5, 5.2-12
M68HC05X16EVS	2.5-40	PC68HC711M2	2.5-25	P6KE22A	5.2-4, 5.2-12
M68HC05X4EVS	2.5-41	PC68HC711N4	2.5-25	P6KE22CA	5.2-4, 5.2-12
M68HC11EVB	2.5-41	PZTA14T1	5.1-16	P6KE24A	5.2-4, 5.2-12
M68HC11EVB	2.5-41	PZTA42T1	5.1-16	P6KE24CA	5.2-4, 5.2-12
M68HC11EVB2	2.5-41	PZTA64T1	5.1-16	P6KE27A	5.2-4, 5.2-12
M68HC11EVM	2.5-41	PZTA92T1	5.1-16	P6KE27CA	5.2-4, 5.2-12
M68HC705F8PGMR	2.5-40	PZTA96T1	5.1-16	P6KE30A	5.2-4, 5.2-12
M68HC705G1PGMR	2.5-40	PZT2222AT1	5.1-15	P6KE30CA	5.2-4, 5.2-12
M68HC705G9PGMR	2.5-40	PZT2907AT1	5.1-15	P6KE33A	5.2-4, 5.2-12
M68HC705J2PGMR	2.5-40	PZT651T1	5.1-16	P6KE33CA	5.2-4, 5.2-12
M68HC705KICS	2.5-40	PZT751T1	5.1-16	P6KE36A	5.2-4, 5.2-12
M68HC705KIGANG	2.5-40	P2N2222A	5.1-7	P6KE36CA	5.2-4, 5.2-12
M68HC705L2PGMR	2.5-41	P2N2907A	5.1-7	P6KE39A	5.2-4, 5.2-12
M68HC705L4PGMR	2.5-41	P6KE10A	5.2-4, 5.2-12	P6KE39CA	5.2-4, 5.2-12
M68HC705L4PGMR	2.5-40	P6KE10CA	5.2-4, 5.2-12	P6KE43A	5.2-4, 5.2-12
M68HC705L5PGMR	2.5-41	P6KE100A	5.2-4, 5.2-12	P6KE43CA	5.2-4, 5.2-12
M68HC705P9PGMR	2.5-41	P6KE100CA	5.2-4, 5.2-12	P6KE47A	5.2-4, 5.2-12
M68HC705T10PGMR	2.5-41	P6KE11A	5.2-4, 5.2-12	P6KE47CA	5.2-4, 5.2-12
M68HC705T12PGMR	2.5-41	P6KE11CA	5.2-4, 5.2-12	P6KE51A	5.2-4, 5.2-12
M68HC705X16PGMR	2.5-41	P6KE110A	5.2-4, 5.2-12	P6KE51CA	5.2-4, 5.2-12
M68HC705X4PGMR	2.5-41	P6KE110CA	5.2-4, 5.2-12	P6KE56A	5.2-4, 5.2-12
M68HC711D3EVB	2.5-41	P6KE12A	5.2-4, 5.2-12	P6KE56CA	5.2-4, 5.2-12
M68MEVB16Z1	2.5-42	P6KE12CA	5.2-4, 5.2-12	P6KE6.8A	5.2-4, 5.2-12
M68MEVB16Z1	2.5-42	P6KE120A	5.2-4, 5.2-12	P6KE6.8CA	5.2-4, 5.2-12
M68MEVB333	2.5-42	P6KE120CA	5.2-4, 5.2-12	P6KE62A	5.2-4, 5.2-12
M68701EVM	2.5-40	P6KE13A	5.2-4, 5.2-12	P6KE62CA	5.2-4, 5.2-12
NC74ACT257	3.1-52	P6KE13CA	5.2-4, 5.2-12	P6KE68A	5.2-4, 5.2-12
NE556A	4.10-2	P6KE130A	5.2-4, 5.2-12	P6KE68CA	5.2-4, 5.2-12
NE556D	4.11-5	P6KE130CA	5.2-4, 5.2-12	P6KE7.5A	5.2-4, 5.2-12
NE556D	4.10-2	P6KE15A	5.2-4, 5.2-12	P6KE7.5CA	5.2-4, 5.2-12
NE556N	4.10-2	P6KE15CA	5.2-4, 5.2-12	P6KE75A	5.2-4, 5.2-12
PBF259	5.1-7	P6KE150A	5.2-5, 5.2-12	P6KE75CA	5.2-4, 5.2-12

# Device Index

P6KE8.2A	5.2-4, 5.2-12	P6SMB43CAT3	5.2-12	SA16CA	5.2-2, 5.2-10
P6KE8.2CA	5.2-4, 5.2-12	P6SMB47AT3	5.2-12	SA160A	5.2-3, 5.2-11
P6KE82A	5.2-4, 5.2-12	P6SMB47CAT3	5.2-12	SA160CA	5.2-3, 5.2-11
P6KE82CA	5.2-4, 5.2-12	P6SMB51AT3	5.2-12	SA17A	5.2-2, 5.2-10
P6KE9.1A	5.2-4, 5.2-12	P6SMB51CAT3	5.2-12	SA17CA	5.2-2, 5.2-10
P6KE9.1CA	5.2-4, 5.2-12	P6SMB56AT3	5.2-12	SA170A	5.2-3, 5.2-11
P6KE91A	5.2-4, 5.2-12	P6SMB56CAT3	5.2-12	SA170CA	5.2-3, 5.2-11
P6KE91CA	5.2-4, 5.2-12	P6SMB6.8AT3	5.2-12	SA18A	5.2-3, 5.2-10
P6SMB10AT3	5.2-12	P6SMB62AT3	5.2-12	SA18CA	5.2-3, 5.2-10
P6SMB100AT3	5.2-12	P6SMB62CAT3	5.2-12	SA20A	5.2-3, 5.2-10
P6SMB11AT3	5.2-12	P6SMB68AT3	5.2-12	SA20CA	5.2-3, 5.2-10
P6SMB11CAT3	5.2-12	P6SMB68CAT3	5.2-12	SA22A	5.2-3, 5.2-10
P6SMB110AT3	5.2-12	P6SMB7.5AT3	5.2-12	SA22CA	5.2-3, 5.2-10
P6SMB12AT3	5.2-12	P6SMB75AT3	5.2-12	SA24A	5.2-3, 5.2-10
P6SMB12CAT3	5.2-12	P6SMB75CAT3	5.2-12	SA24CA	5.2-3, 5.2-10
P6SMB120AT3	5.2-12	P6SMB8.2AT3	5.2-12	SA26A	5.2-3, 5.2-10
P6SMB13AT3	5.2-12	P6SMB82AT3	5.2-12	SA26CA	5.2-3, 5.2-10
P6SMB13CAT3	5.2-12	P6SMB82CAT3	5.2-12	SA28A	5.2-3, 5.2-10
P6SMB130AT3	5.2-12	P6SMB9.1AT3	5.2-12	SA28CA	5.2-3, 5.2-10
P6SMB15AT3	5.2-12	P6SMB91AT3	5.2-12	SA30A	5.2-3, 5.2-10
P6SMB15CAT3	5.2-12	P6SMB91CAT3	5.2-12	SA30CA	5.2-3, 5.2-10
P6SMB150AT3	5.2-12	RFA8090B	5.10-26	SA33A	5.2-3, 5.2-10
P6SMB16AT3	5.2-12	RFA8180B	5.10-26	SA33CA	5.2-3, 5.2-10
P6SMB16CAT3	5.2-12	SAA1042	4.3-9	SA36A	5.2-3, 5.2-10
P6SMB160AT3	5.2-12	SA10A	5.2-2, 5.2-10	SA36CA	5.2-3, 5.2-10
P6SMB170AT3	5.2-12	SA10CA	5.2-2, 5.2-10	SA40A	5.2-3, 5.2-10
P6SMB18AT3	5.2-12	SA100A	5.2-3, 5.2-11	SA40CA	5.2-3, 5.2-10
P6SMB18CAT3	5.2-12	SA100CA	5.2-3, 5.2-11	SA43A	5.2-3, 5.2-10
P6SMB180AT3	5.2-12	SA11A	5.2-2, 5.2-10	SA43CA	5.2-3, 5.2-10
P6SMB20AT3	5.2-12	SA11CA	5.2-2, 5.2-10	SA45A	5.2-3, 5.2-10
P6SMB20CAT3	5.2-12	SA110A	5.2-3, 5.2-11	SA45CA	5.2-3, 5.2-10
P6SMB200AT3	5.2-12	SA110CA	5.2-3, 5.2-11	SA48A	5.2-3, 5.2-10
P6SMB22AT3	5.2-12	SA12A	5.2-2, 5.2-10	SA48CA	5.2-3, 5.2-10
P6SMB22CAT3	5.2-12	SA12CA	5.2-2, 5.2-10	SA5.0A	5.2-2, 5.2-10
P6SMB24AT3	5.2-12	SA120A	5.2-3, 5.2-11	SA5.0CA	5.2-2
P6SMB24CAT3	5.2-12	SA120CA	5.2-3, 5.2-11	SA51A	5.2-3, 5.2-10
P6SMB27AT3	5.2-12	SA13A	5.2-2, 5.2-10	SA51CA	5.2-3, 5.2-10
P6SMB27CAT3	5.2-12	SA13CA	5.2-2, 5.2-10	SA54A	5.2-3, 5.2-10
P6SMB30AT3	5.2-12	SA130A	5.2-3, 5.2-11	SA54CA	5.2-3, 5.2-10
P6SMB30CAT3	5.2-12	SA130CA	5.2-3, 5.2-11	SA58A	5.2-3, 5.2-10
P6SMB33AT3	5.2-12	SA14A	5.2-2, 5.2-10	SA58CA	5.2-3, 5.2-10
P6SMB33CAT3	5.2-12	SA14CA	5.2-2, 5.2-10	SA6.0A	5.2-2, 5.2-10
P6SMB36AT3	5.2-12	SA15A	5.2-2, 5.2-10	SA6.0CA	5.2-2, 5.2-10
P6SMB36CAT3	5.2-12	SA15CA	5.2-2, 5.2-10	SA6.5A	5.2-2, 5.2-10
P6SMB39AT3	5.2-12	SA150A	5.2-3, 5.2-11	SA6.5CA	5.2-2, 5.2-10
P6SMB39CAT3	5.2-12	SA150CA	5.2-3, 5.2-11	SA60A	5.2-3, 5.2-10
P6SMB43AT3	5.2-12	SA16A	5.2-2, 5.2-10	SA60CA	5.2-3, 5.2-10

# Device Index

SA64A	5.2-3, 5.2-10	SL5501S	5.8-9	SN54LS170	3.1-28
SA64CA	5.2-3, 5.2-10	SN54LS00	3.1-27	SN54LS173A	3.1-28
SA7.0A	5.2-2, 5.2-10	SN54LS01	3.1-27	SN54LS174	3.1-28
SA7.0CA	5.2-2, 5.2-10	SN54LS02	3.1-27	SN54LS175	3.1-29
SA7.5A	5.2-2, 5.2-10	SN54LS03	3.1-27	SN54LS181	3.1-29
SA7.5CA	5.2-2, 5.2-10	SN54LS04	3.1-27	SN54LS190	3.1-29
SA70A	5.2-3, 5.2-10	SN54LS05	3.1-27	SN54LS191	3.1-29
SA70CA	5.2-3, 5.2-10	SN54LS08	3.1-27	SN54LS192	3.1-29
SA75A	5.2-3, 5.2-10	SN54LS09	3.1-27	SN54LS193	3.1-29
SA75CA	5.2-3, 5.2-10	SN54LS10	3.1-27	SN54LS194A	3.1-29
SA78A	5.2-3, 5.2-11	SN54LS107A	3.1-28	SN54LS195A	3.1-29
SA78CA	5.2-3, 5.2-11	SN54LS109A	3.1-28	SN54LS196	3.1-29
SA8.0A	5.2-2, 5.2-10	SN54LS11	3.1-27	SN54LS197	3.1-29
SA8.0CA	5.2-2, 5.2-10	SN54LS112A	3.1-28	SN54LS20	3.1-27
SA8.5A	5.2-2, 5.2-10	SN54LS113A	3.1-28	SN54LS21	3.1-27
SA8.5CA	5.2-2, 5.2-10	SN54LS114A	3.1-28	SN54LS22	3.1-27
SA85A	5.2-3, 5.2-11	SN54LS12	3.1-27	SN54LS221	3.1-29
SA85CA	5.2-3, 5.2-11	SN54LS122	3.1-28	SN54LS240	3.1-29
SA9.0A	5.2-2, 5.2-10	SN54LS123	3.1-28	SN54LS241	3.1-29
SA9.0CA	5.2-2, 5.2-10	SN54LS125A	3.1-28	SN54LS242	3.1-29
SA90A	5.2-3, 5.2-11	SN54LS126A	3.1-28	SN54LS243	3.1-29
SA90CA	5.2-3, 5.2-11	SN54LS13	3.1-27	SN54LS244	3.1-29
SC141B	5.7-9	SN54LS132	3.1-28	SN54LS245	3.1-29
SC141D	5.7-9	SN54LS133	3.1-28	SN54LS247	3.1-29
SC141M	5.7-9	SN54LS137	3.1-28	SN54LS248	3.1-29
SC141N	5.7-9	SN54LS138	3.1-28	SN54LS249	3.1-29
SC143B	5.7-9	SN54LS139	3.1-28	SN54LS251	3.1-29
SC143D	5.7-9	SN54LS14	3.1-27	SN54LS253	3.1-29
SC143M	5.7-9	SN54LS145	3.1-28	SN54LS256	3.1-29
SC146B	5.7-12	SN54LS147	3.1-28	SN54LS257B	3.1-29
SC146D	5.7-12	SN54LS148	3.1-28	SN54LS258B	3.1-29
SC146M	5.7-12	SN54LS15	3.1-27	SN54LS259	3.1-29
SC146N	5.7-12	SN54LS151	3.1-28	SN54LS26	3.1-27
SC149B	5.7-13	SN54LS153	3.1-28	SN54LS260	3.1-29
SC149D	5.7-13	SN54LS155	3.1-28	SN54LS266	3.1-29
SC149M	5.7-13	SN54LS156	3.1-28	SN54LS27	3.1-27
SD241	5.6-9	SN54LS157	3.1-28	SN54LS273	3.1-29
SD41	5.6-9	SN54LS158	3.1-28	SN54LS279	3.1-29
SD51	5.6-9	SN54LS160A	3.1-28	SN54LS28	3.1-27
SG3525A	4.2-10	SN54LS161A	3.1-28	SN54LS280	3.1-29
SG3526	4.2-10	SN54LS162A	3.1-28	SN54LS283	3.1-29
SG3527A	4.2-10	SN54LS163A	3.1-28	SN54LS290	3.1-29
SL5500	5.8-6	SN54LS164	3.1-28	SN54LS293	3.1-29
SL5500F	5.8-9	SN54LS165	3.1-28	SN54LS298	3.1-29
SL5500S	5.8-9	SN54LS166	3.1-28	SN54LS299	3.1-29
SL5501	5.8-6	SN54LS168	3.1-28	SN54LS30	3.1-27
SL5501F	5.8-9	SN54LS169	3.1-28	SN54LS32	3.1-27

# Device Index

SN54LS322A	3.1-29	SN54LS75	3.1-27	SN74LS151	3.1-28
SN54LS323	3.1-29	SN54LS76A	3.1-27	SN74LS153	3.1-28
SN54LS33	3.1-27	SN54LS77	3.1-27	SN74LS155	3.1-28
SN54LS348	3.1-29	SN54LS795	3.1-30	SN74LS156	3.1-28
SN54LS352	3.1-29	SN54LS796	3.1-30	SN74LS157	3.1-28
SN54LS353	3.1-30	SN54LS797	3.1-30	SN74LS158	3.1-28
SN54LS365A	3.1-30	SN54LS798	3.1-30	SN74LS160A	3.1-28
SN54LS366A	3.1-30	SN54LS83A	3.1-27	SN74LS161A	3.1-28
SN54LS367A	3.1-30	SN54LS848	3.1-30	SN74LS162A	3.1-28
SN54LS368A	3.1-30	SN54LS85	3.1-27	SN74LS163A	3.1-28
SN54LS37	3.1-27	SN54LS86	3.1-27	SN74LS164	3.1-28
SN54LS373	3.1-30	SN54LS90	3.1-28	SN74LS165	3.1-28
SN54LS374	3.1-30	SN54LS92	3.1-28	SN74LS166	3.1-28
SN54LS375	3.1-30	SN54LS93	3.1-28	SN74LS168	3.1-28
SN54LS377	3.1-30	SN54LS95B	3.1-28	SN74LS169	3.1-28
SN54LS378	3.1-30	SN74LS00	3.1-27	SN74LS170	3.1-28
SN54LS379	3.1-30	SN74LS01	3.1-27	SN74LS173A	3.1-28
SN54LS38	3.1-27	SN74LS02	3.1-27	SN74LS174	3.1-28
SN54LS386	3.1-30	SN74LS03	3.1-27	SN74LS175	3.1-29
SN54LS390	3.1-30	SN74LS04	3.1-27	SN74LS181	3.1-29
SN54LS393	3.1-30	SN74LS05	3.1-27	SN74LS190	3.1-29
SN54LS398	3.1-30	SN74LS08	3.1-27	SN74LS191	3.1-29
SN54LS399	3.1-30	SN74LS09	3.1-27	SN74LS192	3.1-29
SN54LS40	3.1-27	SN74LS10	3.1-27	SN74LS193	3.1-29
SN54LS42	3.1-27	SN74LS107A	3.1-28	SN74LS194A	3.1-29
SN54LS47	3.1-27	SN74LS109A	3.1-28	SN74LS195A	3.1-29
SN54LS48	3.1-27	SN74LS11	3.1-27	SN74LS196	3.1-29
SN54LS490	3.1-30	SN74LS112A	3.1-28	SN74LS197	3.1-29
SN54LS51	3.1-27	SN74LS113A	3.1-28	SN74LS20	3.1-27
SN54LS54	3.1-27	SN74LS114A	3.1-28	SN74LS21	3.1-27
SN54LS540	3.1-30	SN74LS12	3.1-27	SN74LS22	3.1-27
SN54LS541	3.1-30	SN74LS122	3.1-28	SN74LS221	3.1-29
SN54LS55	3.1-27	SN74LS123	3.1-28	SN74LS240	3.1-29
SN54LS569A	3.1-30	SN74LS125A	3.1-28	SN74LS241	3.1-29
SN54LS623	3.1-30	SN74LS126A	3.1-28	SN74LS242	3.1-29
SN54LS640	3.1-30	SN74LS13	3.1-27	SN74LS243	3.1-29
SN54LS641	3.1-30	SN74LS132	3.1-28	SN74LS244	3.1-29
SN54LS642	3.1-30	SN74LS133	3.1-28	SN74LS245	3.1-29
SN54LS645	3.1-30	SN74LS136	3.1-28	SN74LS247	3.1-29
SN54LS669	3.1-30	SN74LS137	3.1-28	SN74LS248	3.1-29
SN54LS670	3.1-30	SN74LS138	3.1-28	SN74LS249	3.1-29
SN54LS682	3.1-30	SN74LS139	3.1-28	SN74LS251	3.1-29
SN54LS684	3.1-30	SN74LS14	3.1-27	SN74LS253	3.1-29
SN54LS688	3.1-30	SN74LS145	3.1-28	SN74LS256	3.1-29
SN54LS73A	3.1-27	SN74LS147	3.1-28	SN74LS257B	3.1-29
SN54LS74A	3.1-27	SN74LS148	3.1-28	SN74LS258B	3.1-29
SN54LS748	3.1-30	SN74LS15	3.1-27	SN74LS259	3.1-29

# Device Index

SN74LS26	3.1-27	SN74LS541	3.1-30	TDA3190	4.8-5
SN74LS260	3.1-29	SN74LS55	3.1-27	TDA3301B	4.8-3
SN74LS266	3.1-29	SN74LS569A	3.1-30	TDA3330	4.8-3
SN74LS27	3.1-27	SN74LS623	3.1-30	TIL111	5.8-6
SN74LS273	3.1-29	SN74LS640	3.1-30	TIL111F	5.8-9
SN74LS279	3.1-29	SN74LS641	3.1-30	TIL111S	5.8-9
SN74LS28	3.1-27	SN74LS642	3.1-30	TIL112	5.8-6
SN74LS280	3.1-29	SN74LS645	3.1-30	TIL112F	5.8-9
SN74LS283	3.1-29	SN74LS669	3.1-30	TIL112S	5.8-9
SN74LS290	3.1-29	SN74LS670	3.1-30	TIL113	5.8-7
SN74LS293	3.1-29	SN74LS682	3.1-30	TIL113F	5.8-10
SN74LS298	3.1-29	SN74LS684	3.1-30	TIL113S	5.8-10
SN74LS299	3.1-29	SN74LS688	3.1-30	TIL116	5.8-6
SN74LS30	3.1-27	SN74LS724	4.7-31	TIL116F	5.8-9
SN74LS32	3.1-27	SN74LS73A	3.1-27	TIL116S	5.8-9
SN74LS322A	3.1-29	SN74LS74A	3.1-27	TIL117	5.8-6
SN74LS323	3.1-29	SN74LS748	3.1-30	TIL117F	5.8-9
SN74LS33	3.1-27	SN74LS75	3.1-27	TIL117S	5.8-9
SN74LS348	3.1-29	SN74LS76A	3.1-27	TIL119	5.8-7
SN74LS352	3.1-29	SN74LS77	3.1-27	TIL119F	5.8-10
SN74LS353	3.1-30	SN74LS795	3.1-30	TIL119S	5.8-10
SN74LS365A	3.1-30	SN74LS796	3.1-30	TIL126	5.8-6
SN74LS366A	3.1-30	SN74LS797	3.1-30	TIL126F	5.8-9
SN74LS367A	3.1-30	SN74LS798	3.1-30	TIL126S	5.8-9
SN74LS368A	3.1-30	SN74LS83A	3.1-27	TIP100	5.5-6
SN74LS37	3.1-27	SN74LS848	3.1-30	TIP101	5.5-6
SN74LS373	3.1-30	SN74LS85	3.1-27	TIP102	5.5-6
SN74LS374	3.1-30	SN74LS86	3.1-27	TIP105	5.5-6
SN74LS375	3.1-30	SN74LS90	3.1-28	TIP106	5.5-6
SN74LS377	3.1-30	SN74LS92	3.1-28	TIP107	5.5-6
SN74LS378	3.1-30	SN74LS93	3.1-28	TIP110	5.5-4
SN74LS379	3.1-30	SN74LS95B	3.1-28	TIP111	5.5-4
SN74LS38	3.1-27	SN75173	4.6-6	TIP112	5.5-4
SN74LS386	3.1-30	SN75175	4.6-6	TIP115	5.5-4
SN74LS390	3.1-30	S2800A	5.7-5	TIP116	5.5-4
SN74LS393	3.1-30	S2800B	5.7-5	TIP117	5.5-4
SN74LS395	3.1-30	S2800D	5.7-5	TIP120	5.5-5
SN74LS398	3.1-30	S2800F	5.7-5	TIP121	5.5-5
SN74LS399	3.1-30	S2800M	5.7-5	TIP122	5.5-5
SN74LS40	3.1-27	S2800N	5.7-5	TIP125	5.5-5
SN74LS42	3.1-27	TCA0372	4.1-5	TIP126	5.5-5
SN74LS47	3.1-27	TCA5600	4.2-11	TIP127	5.5-5
SN74LS48	3.1-27	TCF5600	4.2-11	TIP140	5.5-7
SN74LS490	3.1-30	TCF6000	4.9-3	TIP141	5.5-7
SN74LS51	3.1-27	TDA1085A	4.3-10	TIP142	5.5-7
SN74LS54	3.1-27	TDA1085C	4.3-10	TIP145	5.5-7
SN74LS540	3.1-30	TDA1185A	4.3-11	TIP146	5.5-7



# Device Index

TIP147	5.5-7	TL072ACD	4.11-5	TP3019S	5.10-9
TIP29B	5.5-4	TL072C	4.1-4	TP3020A	5.10-9
TIP29C	5.5-4	TL072CD	4.11-5	TP3022B	5.10-9
TIP2955	5.5-8	TL072M	4.1-5	TP3024B	5.10-9
TIP30B	5.5-4	TL074AC	4.1-6	TP3032	5.10-9
TIP30C	5.5-4	TL074C	4.1-6	TP3034	5.10-9
TIP3055	5.5-8	TL074M	4.1-6	TP3061	5.10-9
TIP31A	5.5-4	TL081AC	4.1-3	TP3062	5.10-9
TIP31B	5.5-4	TL081ACD	4.11-5	TP3064	5.10-9
TIP31C	5.5-4	TL081C	4.1-3	TP3069	5.10-9
TIP32A	5.5-4	TL081CD	4.11-5	TP5002S	5.10-8
TIP32B	5.5-4	TL081M	4.1-3	TP5051	5.10-8
TIP32C	5.5-4	TL082AC	4.1-4	TP62601	5.10-12
TIP33B	5.5-7	TL082ACD	4.11-5	T2322B	5.7-7
TIP33C	5.5-7	TL082C	4.1-4	T2322D	5.7-7
TIP34B	5.5-7	TL082CD	4.11-5	T2322M	5.7-7
TIP34C	5.5-7	TL082M	4.1-5	T2323B	5.7-8
TIP35A	5.5-8	TL084AC	4.1-6	T2323D	5.7-8
TIP35B	5.5-8	TL084C	4.1-6	T2323M	5.7-8
TIP35C	5.5-8	TL084M	4.1-6	T2500B	5.7-8
TIP36A	5.5-8	TL431AC	4.4-2	T2500BFP	5.7-9
TIP36B	5.5-8	TL431ACD	4.11-5	T2500D	5.7-8
TIP36C	5.5-8	TL431AID	4.11-5	T2500DFP	5.7-9
TIP41A	5.5-5	TL431BC	4.4-2	T2500M	5.7-8
TIP41B	5.5-5	TL431C	4.4-2	T2500MFP	5.7-9
TIP41C	5.5-5	TL431I	4.4-2	T2500N	5.7-8
TIP42A	5.5-5	TL431M	4.4-2	T2500NFP	5.7-9
TIP42B	5.5-5	TL4311AI	4.4-2	T2800B	5.7-10
TIP42C	5.5-5	TL4311BI	4.4-2	T2800D	5.7-10
TIP47	5.5-4	TL494	4.2-10	T2800M	5.7-10
TIP48	5.5-4	TL594	4.2-10	T2801B	5.7-9
TIP49	5.5-4	TL780-05C	4.2-3	T2801D	5.7-9
TIP50	5.5-4	TL780-12C	4.2-4	T2801M	5.7-9
TL062AC	4.1-4	TL780-15C	4.2-4	T2802B	5.7-11
TL062C	4.1-4	TPV595A	5.10-13	T2802D	5.7-11
TL062M	4.1-5	TPV596A	5.10-13	T2802M	5.7-11
TL062V	4.1-4	TPV597	5.10-13	T68HC000ADCXH	6.4-8
TL064AC	4.1-5	TPV598	5.10-13	T68HC000ARCXH	6.4-8
TL064C	4.1-5	TPV6030	5.10-13	T68HC000CDCXH	6.4-8
TL064CD	4.11-5	TPV695A	5.10-13	T68HC000CRCXH	6.4-8
TL064M	4.1-6	TPV7025	5.10-13	T68000ADCXH	6.4-8
TL064V	4.1-6	TPV8100B	5.10-13	T68000ARCXH	6.4-8
TL071AC	4.1-3	TPV8200B	5.10-13	T68000CDCXH	6.4-8
TL071ACD	4.11-5	TP3005	5.10-9	T68000CRCXH	6.4-8
TL071C	4.1-3	TP3006	5.10-9	T68020ARCXH	6.4-8
TL071CD	4.11-5	TP3007S	5.10-9	T68020ASCXH	6.4-8
TL072AC	4.1-4	TP3008	5.10-9	T68020CRCXH	6.4-8

# Device Index

T68020CSCXH	6.4-8	UC3845B	4.2-8	XC68HC05L6	2.5-10
T68882ARCXH	6.4-9	UC3845BD	4.11-5	XC68HC05M4	2.5-11, 2.5-41
T68882ASCXH	6.4-9	UC3845BD1	4.11-5	XC68HC05M6	2.5-11
T68882CRCXH	6.4-9	UC3845BV	4.2-8	XC68HC05PE0	2.5-12
T68882CSCXH	6.4-9	UC3845D	4.11-5	XC68HC05P1A	2.5-11
UAA1016B	4.3-3	ULN2001A	4.6-7	XC68HC05P10	2.5-11
UAA1041B	4.9-3	ULN2002A	4.6-7	XC68HC05P3	2.5-11, 2.5-41
UAA1041D	4.11-5	ULN2003A	4.6-7	XC68HC05SC11	2.5-12, 2.5-41
UC2842A	4.2-7	ULN2004A	4.6-7	XC68HC05SC21	2.5-12, 2.5-41
UC2842AD	4.11-5	ULN2068B	4.6-8	XC68HC05SC24	2.5-12, 2.5-41
UC2842B	4.2-8	ULN2801	4.6-7	XC68HC05SC27	2.5-12, 2.5-41
UC2842BD	4.11-5	ULN2802	4.6-7	XC68HC05T12	2.5-13, 2.5-41
UC2842BD1	4.11-5	ULN2803	4.6-7	XC68HC05T2	2.5-12, 2.5-41
UC2843A	4.2-7	ULN2804	4.6-7	XC68HC05T3	2.5-12, 2.5-41
UC2843AD	4.11-5	VN0300L	5.1-22	XC68HC05T4	2.5-12, 2.5-41
UC2843B	4.2-8	VN0610LL	5.1-22	XC68HC05X16	2.5-13, 2.5-41
UC2843BD	4.11-5	VN10LM	5.1-22	XC68HC05X4	2.5-13, 2.5-41
UC2843BD1	4.11-5	VN1706L	5.1-22	XC68HC11C0	2.5-23
UC2844	4.2-7	VN2222LL	5.1-22	XC68HC11E20	2.5-23
UC2844B	4.2-8	VN2406L	5.1-22	XC68HC11N4	2.5-25
UC2844BD	4.11-5	VN2410L	5.1-22	XC68HC11P2	2.5-25
UC2844BD1	4.11-5	XC56002FC66	2.1-4	XC68HC705C	2.5-40
UC2844D	4.11-5	XC56004FJ40	2.1-4	XC68HC705C5	2.5-13, 2.5-40
UC2845	4.2-8	XC56156FE40	2.1-2	XC68HC705C8A	2.5-13
UC2845B	4.2-8	XC56156FE60	2.1-2	XC68HC705C9	2.5-13
UC2845BD	4.11-5	XC56166FE60	2.1-2	XC68HC705D9	2.5-13
UC2845BD1	4.11-5	XC56200LC10	2.1-5	XC68HC705E24	2.5-14
UC2845D	4.11-5	XC68HC05B16	2.5-7	XC68HC705F4	2.5-14
UC3842A	4.2-7	XC68HC05CC1	2.5-7	XC68HC705F6	2.5-14
UC3842AD	4.11-5	XC68HC05C4	2.5-40	XC68HC705F8	2.5-14, 2.5-40
UC3842B	4.2-8	XC68HC05C9A	2.5-7	XC68HC705G10	2.5-15, 2.5-40
UC3842BD	4.11-5	XC68HC05D32	2.5-8, 2.5-40	XC68HC705G9	2.5-14, 2.5-40
UC3842BD1	4.11-5	XC68HC05F2	2.5-8, 2.5-40	XC68HC705H2	2.5-15
UC3842BV	4.2-7	XC68HC05F6	2.5-40	XC68HC705I8	2.5-15, 2.5-40
UC3843A	4.2-7	XC68HC05F8	2.5-8, 2.5-40	XC68HC705J3	2.5-15, 2.5-40
UC3843AD	4.11-5	XC68HC05G10	2.5-9, 2.5-40	XC68HC705K1	2.5-15, 2.5-40
UC3843B	4.2-8	XC68HC05G9	2.5-8, 2.5-40	XC68HC705L1	2.5-15, 2.5-41
UC3843BD	4.11-5	XC68HC05H2	2.5-9, 2.5-40	XC68HC705L2	2.5-15, 2.5-41
UC3843BD1	4.11-5	XC68HC05I8	2.5-9, 2.5-40	XC68HC705L4	2.5-41
UC3843BV	4.2-7	XC68HC05J3	2.5-9, 2.5-40	XC68HC705P6	2.5-16
UC3844	4.2-7	XC68HC05K0	2.5-9	XC68HC705P9	2.5-16, 2.5-41
UC3844B	4.2-8	XC68HC05K0/K1	2.5-40	XC68HC705T10	2.5-16, 2.5-41
UC3844BD	4.11-5	XC68HC05K1	2.5-9	XC68HC705T12	2.5-16, 2.5-41
UC3844BD1	4.11-5	XC68HC05L1	2.5-9, 2.5-41	XC68HC705T3	2.5-16
UC3844BV	4.2-8	XC68HC05L11	2.5-10, 2.5-41	XC68HC705T4	2.5-16
UC3844D	4.11-5	XC68HC05L2	2.5-9, 2.5-41	XC68HC705X4	2.5-16, 2.5-41
UC3845	4.2-7	XC68HC05L4	2.5-10, 2.5-41	XC68HC711P2	2.5-25

# Device Index

XC68HC916X1	2.5-35	1.5KE11A	5.2-7, 5.2-13	1.5KE39CA	5.2-7, 5.2-13
XC68HC916Y1	2.5-35	1.5KE11CA	5.2-7, 5.2-13	1.5KE43A	5.2-7, 5.2-13
XC68H05P15	2.5-11	1.5KE110A	5.2-7, 5.2-13	1.5KE43CA	5.2-7, 5.2-13
XC68334	2.5-38	1.5KE110CA	5.2-7, 5.2-13	1.5KE47A	5.2-7, 5.2-13
XC96002RC33	2.1-5	1.5KE12A	5.2-7, 5.2-13	1.5KE47CA	5.2-7, 5.2-13
XC96002RC40	2.1-5	1.5KE12CA	5.2-7, 5.2-13	1.5KE51A	5.2-7, 5.2-13
XMC145474	4.7-9	1.5KE120A	5.2-7, 5.2-13	1.5KE51CA	5.2-7, 5.2-13
XMC145475	4.7-9	1.5KE120CA	5.2-7, 5.2-13	1.5KE56A	5.2-7, 5.2-13
ZPD10RL	5.2-16	1.5KE13A	5.2-7, 5.2-13	1.5KE56CA	5.2-7, 5.2-13
ZPD11RL	5.2-16	1.5KE13CA	5.2-7, 5.2-13	1.5KE6.8A	5.2-7, 5.2-13
ZPD12RL	5.2-16	1.5KE130A	5.2-7, 5.2-13	1.5KE6.8CA	5.2-7, 5.2-13
ZPD13RL	5.2-16	1.5KE130CA	5.2-7, 5.2-13	1.5KE62A	5.2-7, 5.2-13
ZPD15RL	5.2-16	1.5KE15A	5.2-7, 5.2-13	1.5KE62CA	5.2-7, 5.2-13
ZPD16RL	5.2-16	1.5KE15CA	5.2-7, 5.2-13	1.5KE68A	5.2-7, 5.2-13
ZPD18RL	5.2-16	1.5KE150A	5.2-8, 5.2-13	1.5KE68CA	5.2-7, 5.2-13
ZPD2.7RL	5.2-16	1.5KE150CA	5.2-8, 5.2-13	1.5KE7.5A	5.2-7, 5.2-13
ZPD20RL	5.2-17	1.5KE16A	5.2-7, 5.2-13	1.5KE7.5CA	5.2-7, 5.2-13
ZPD22RL	5.2-17	1.5KE16CA	5.2-7, 5.2-13	1.5KE75A	5.2-7, 5.2-13
ZPD24RL	5.2-17	1.5KE160A	5.2-8, 5.2-13	1.5KE75CA	5.2-7, 5.2-13
ZPD27RL	5.2-17	1.5KE160CA	5.2-8, 5.2-13	1.5KE8.2A	5.2-7, 5.2-13
ZPD3.0RL	5.2-16	1.5KE170A	5.2-8, 5.2-13	1.5KE8.2CA	5.2-7, 5.2-13
ZPD3.3RL	5.2-16	1.5KE170CA	5.2-8, 5.2-13	1.5KE82A	5.2-7, 5.2-13
ZPD3.6RL	5.2-16	1.5KE18A	5.2-7, 5.2-13	1.5KE82CA	5.2-7, 5.2-13
ZPD3.9RL	5.2-16	1.5KE18CA	5.2-7, 5.2-13	1.5KE9.1A	5.2-7, 5.2-13
ZPD30RL	5.2-17	1.5KE180A	5.2-8, 5.2-13	1.5KE9.1CA	5.2-7, 5.2-13
ZPD33RL	5.2-17	1.5KE180CA	5.2-8, 5.2-13	1.5KE91A	5.2-7, 5.2-13
ZPD4.3RL	5.2-16	1.5KE20A	5.2-7, 5.2-13	1.5KE91CA	5.2-7, 5.2-13
ZPD4.7RL	5.2-16	1.5KE20CA	5.2-7, 5.2-13	1.5SMC10AT3	5.2-13
ZPD5.1RL	5.2-16	1.5KE200A	5.2-8, 5.2-13	1.5SMC11AT3	5.2-13
ZPD5.6RL	5.2-16	1.5KE200CA	5.2-8, 5.2-13	1.5SMC12AT3	5.2-13
ZPD6.2RL	5.2-16	1.5KE22A	5.2-7, 5.2-13	1.5SMC13AT3	5.2-13
ZPD6.8RL	5.2-16	1.5KE22CA	5.2-7, 5.2-13	1.5SMC15AT3	5.2-13
ZPD7.5RL	5.2-16	1.5KE220A	5.2-8	1.5SMC16AT3	5.2-13
ZPD8.2RL	5.2-16	1.5KE220CA	5.2-8	1.5SMC18AT3	5.2-13
ZPD9.1RL	5.2-16	1.5KE24A	5.2-7, 5.2-13	1.5SMC20AT3	5.2-13
μA78S40	4.2-9	1.5KE24CA	5.2-7, 5.2-13	1.5SMC22AT3	5.2-13
μA9636A	4.6-6	1.5KE250A	5.2-8	1.5SMC24AT3	5.2-13
071M/YBDGAQ	6.4-24	1.5KE250CA	5.2-8	1.5SMC27AT3	5.2-13
072M/YBDGAQ	6.4-24	1.5KE27A	5.2-7, 5.2-13	1.5SMC30AT3	5.2-13
074M/YBDGAQ	6.4-24	1.5KE27CA	5.2-7, 5.2-13	1.5SMC33AT3	5.2-13
081M/YBDGAQ	6.4-24	1.5KE30A	5.2-7, 5.2-13	1.5SMC36AT3	5.2-13
082M/YBDGAQ	6.4-24	1.5KE30CA	5.2-7, 5.2-13	1.5SMC39AT3	5.2-13
084M/YBDGAQ	6.4-24	1.5KE33A	5.2-7, 5.2-13	1.5SMC43AT3	5.2-13
1.5KE10A	5.2-7, 5.2-13	1.5KE33CA	5.2-7, 5.2-13	1.5SMC47AT3	5.2-13
1.5KE10CA	5.2-7, 5.2-13	1.5KE36A	5.2-7, 5.2-13	1.5SMC51AT3	5.2-13
1.5KE100A	5.2-7, 5.2-13	1.5KE36CA	5.2-7, 5.2-13	1.5SMC56AT3	5.2-13
1.5KE100CA	5.2-7, 5.2-13	1.5KE39A	5.2-7, 5.2-13	1.5SMC6.8AT3	5.2-13

# Device Index

1.5SMC62AT3	5.2-13	1C985BHV	6.3-22	1N4705	5.2-16
1.5SMC68AT3	5.2-13	1C986BHV	6.3-22	1N4706	5.2-17
1.5SMC7.5AT3	5.2-13	1C987BHV	6.3-22	1N4707	5.2-17
1.5SMC75AT3	5.2-13	1C988BHV	6.3-22	1N4708	5.2-17
1.5SMC8.2AT3	5.2-13	1C989BHV	6.3-22	1N4709	5.2-17
1.5SMC82AT3	5.2-13	1C990BHV	6.3-22	1N4710	5.2-17
1.5SMC9.1AT3	5.2-13	1C991BHV	6.3-22	1N4711	5.2-17
1.5SMC91AT3	5.2-13	1C992BHV	6.3-22	1N4712	5.2-17
1C4370AHV	6.3-22	1M110ZS5	5.2-19	1N4713	5.2-17
1C4371AHV	6.3-22	1M120ZS5	5.2-19	1N4714	5.2-17
1C4372AHV	6.3-22	1M130ZS5	5.2-19	1N4715	5.2-17
1C746AHV	6.3-22	1M150ZS5	5.2-19	1N4716	5.2-17
1C747AHV	6.3-22	1M160ZS5	5.2-19	1N4717	5.2-17
1C748AHV	6.3-22	1M180ZS5	5.2-19	1N4728A	5.2-18
1C749AHV	6.3-22	1M200ZS5	5.2-19	1N4729A	5.2-18
1C750AHV	6.3-22	1N4004	5.6-14	1N4730A	5.2-18
1C751AHV	6.3-22	1N4007	5.6-14	1N4731A	5.2-18
1C752AHV	6.3-22	1N4370A	5.2-16	1N4732A	5.2-18
1C753AHV	6.3-22	1N4371A	5.2-16	1N4733A	5.2-18
1C754AHV	6.3-22	1N4372A	5.2-16	1N4734A	5.2-18
1C755AHV	6.3-22	1N4678	5.2-16	1N4734AA/NBP	6.4-32
1C756AHV	6.3-22	1N4679	5.2-16	1N4735A	5.2-18
1C757AHV	6.3-22	1N4680	5.2-16	1N4736A	5.2-18
1C758AHV	6.3-22	1N4681	5.2-16	1N4737A	5.2-18
1C759AHV	6.3-22	1N4682	5.2-16	1N4738A	5.2-18
1C962BHV	6.3-22	1N4683	5.2-16	1N4739A	5.2-18
1C964BHV	6.3-22	1N4684	5.2-16	1N4740A	5.2-18
1C965BHV	6.3-22	1N4685	5.2-16	1N4741A	5.2-18
1C966BHV	6.3-22	1N4686	5.2-16	1N4742A	5.2-18
1C967BHV	6.3-22	1N4687	5.2-16	1N4743A	5.2-18
1C968BHV	6.3-22	1N4688	5.2-16	1N4744A	5.2-18
1C969BHV	6.3-22	1N4689	5.2-16	1N4745A	5.2-18
1C970BHV	6.3-22	1N4690	5.2-16	1N4746A	5.2-18
1C971BHV	6.3-22	1N4691	5.2-16	1N4746AA/NBP	6.4-32
1C972BHV	6.3-22	1N4692	5.2-16	1N4747A	5.2-18
1C973BHV	6.3-22	1N4693	5.2-16	1N4747AA/NBP	6.4-32
1C974BHV	6.3-22	1N4694	5.2-16	1N4748A	5.2-18
1C975BHV	6.3-22	1N4695	5.2-16	1N4748AA/NBP	6.4-32
1C976BHV	6.3-22	1N4696	5.2-16	1N4749A	5.2-18
1C977BHV	6.3-22	1N4697	5.2-16	1N4749AA/NBP	6.4-32
1C978BHV	6.3-22	1N4698	5.2-16	1N4750A	5.2-18
1C979BHV	6.3-22	1N4699	5.2-16	1N4750AA/NBP	6.4-32
1C980BHV	6.3-22	1N4700	5.2-16	1N4751A	5.2-18
1C981BHV	6.3-22	1N4701	5.2-16	1N4751AA/NBP	6.4-32
1C982BHV	6.3-22	1N4702	5.2-16	1N4752A	5.2-18
1C983BHV	6.3-22	1N4703	5.2-16	1N4752AA/NBP	6.4-32
1C984BHV	6.3-22	1N4704	5.2-16	1N4753A	5.2-18

# Device Index

1N4753AA/NBP	6.4-32	1N5230B	5.2-16	1N5277B	5.2-17
1N4754A	5.2-18	1N5231B	5.2-16	1N5278B	5.2-17
1N4754AA/NBP	6.4-32	1N5232B	5.2-16	1N5279B	5.2-17
1N4755A	5.2-18	1N5233B	5.2-16	1N5280B	5.2-17
1N4755AA/NBP	6.4-32	1N5234B	5.2-16	1N5281B	5.2-17
1N4756A	5.2-18	1N5235B	5.2-16	1N5283	5.2-31
1N4756AA/NBP	6.4-32	1N5236B	5.2-16	1N5284	5.2-31
1N4757A	5.2-18	1N5237B	5.2-16	1N5285	5.2-31
1N4757AA/NBP	6.4-32	1N5238B	5.2-16	1N5286	5.2-31
1N4758A	5.2-18	1N5239B	5.2-16	1N5287	5.2-31
1N4758AA/NBP	6.4-32	1N5240B	5.2-16	1N5288	5.2-32
1N4759A	5.2-18	1N5241B	5.2-16	1N5289	5.2-32
1N4759AA/NBP	6.4-32	1N5242B	5.2-16	1N5290	5.2-32
1N4760A	5.2-18	1N5243B	5.2-16	1N5291	5.2-32
1N4760AA/NBP	6.4-32	1N5244B	5.2-16	1N5292	5.2-32
1N4761A	5.2-19	1N5245B	5.2-16	1N5293	5.2-32
1N4761AA/NBP	6.4-32	1N5246B	5.2-16	1N5294	5.2-32
1N4762A	5.2-19	1N5247B	5.2-16	1N5295	5.2-32
1N4762AA/NBP	6.4-32	1N5248B	5.2-16	1N5296	5.2-32
1N4763A	5.2-19	1N5249B	5.2-17	1N5297	5.2-32
1N4763AA/NBP	6.4-32	1N5250B	5.2-17	1N5298	5.2-32
1N4764A	5.2-19	1N5251B	5.2-17	1N5299	5.2-32
1N4764AA/NBP	6.4-32	1N5252B	5.2-17	1N5300	5.2-32
1N4935	5.6-14	1N5253B	5.2-17	1N5301	5.2-32
1N4935X/NBP	6.4-32	1N5254B	5.2-17	1N5302	5.2-32
1N4936X/NBP	6.4-32	1N5255B	5.2-17	1N5303	5.2-32
1N4937	5.6-14	1N5256B	5.2-17	1N5304	5.2-32
1N4937X/NBP	6.4-32	1N5257B	5.2-17	1N5305	5.2-32
1N5139	5.1-26	1N5258B	5.2-17	1N5306	5.2-32
1N5140	5.1-26	1N5259B	5.2-17	1N5307	5.2-32
1N5141	5.1-26	1N5260B	5.2-17	1N5308	5.2-32
1N5142	5.1-26	1N5261B	5.2-17	1N5309	5.2-32
1N5143	5.1-26	1N5262B	5.2-17	1N5310	5.2-32
1N5144	5.1-26	1N5263B	5.2-17	1N5311	5.2-32
1N5145	5.1-26	1N5264B	5.2-17	1N5312	5.2-32
1N5146	5.1-26	1N5265B	5.2-17	1N5313	5.2-32
1N5147	5.1-26	1N5266B	5.2-17	1N5314	5.2-32
1N5148	5.1-26	1N5267B	5.2-17	1N5314X/NBP	6.4-32
1N5221B	5.2-16	1N5268B	5.2-17	1N5333B	5.2-18
1N5222B	5.2-16	1N5269B	5.2-17	1N5334B	5.2-18
1N5223B	5.2-16	1N5270B	5.2-17	1N5335B	5.2-18
1N5224B	5.2-16	1N5271B	5.2-17	1N5336B	5.2-18
1N5225B	5.2-16	1N5272B	5.2-17	1N5337B	5.2-18
1N5226B	5.2-16	1N5273B	5.2-17	1N5338B	5.2-18
1N5227B	5.2-16	1N5274B	5.2-17	1N5339B	5.2-18
1N5228B	5.2-16	1N5275B	5.2-17	1N5340B	5.2-18
1N5229B	5.2-16	1N5276B	5.2-17	1N5341B	5.2-18

# Device Index

1N5342B	5.2-18	1N5388B	5.2-19	1N5919B	5.2-18
1N5343B	5.2-18	1N5404	5.6-14	1N5920B	5.2-18
1N5344B	5.2-18	1N5406	5.6-14	1N5921B	5.2-18
1N5345B	5.2-18	1N5441A	5.1-26	1N5922B	5.2-18
1N5346B	5.2-18	1N5443A	5.1-26	1N5923B	5.2-18
1N5347B	5.2-18	1N5444A	5.1-26	1N5924B	5.2-18
1N5348B	5.2-18	1N5445A	5.1-26	1N5925B	5.2-18
1N5349B	5.2-18	1N5446A	5.1-26	1N5926B	5.2-18
1N5350B	5.2-18	1N5448A	5.1-26	1N5927B	5.2-18
1N5351B	5.2-18	1N5449A	5.1-26	1N5928B	5.2-18
1N5352B	5.2-18	1N5450A	5.1-26	1N5929B	5.2-18
1N5353B	5.2-18	1N5451A	5.1-26	1N5930B	5.2-18
1N5354B	5.2-18	1N5452A	5.1-26	1N5931B	5.2-18
1N5355B	5.2-18	1N5453A	5.1-26	1N5932B	5.2-18
1N5356B	5.2-18	1N5455A	5.1-26	1N5933B	5.2-18
1N5357B	5.2-18	1N5456A	5.1-26	1N5934B	5.2-18
1N5358B	5.2-18	1N5817	5.6-6	1N5935B	5.2-18
1N5359B	5.2-18	1N5817X/NBP	6.4-32	1N5936B	5.2-18
1N5359BA/NBP	6.4-32	1N5818	5.6-6	1N5937B	5.2-18
1N5360B	5.2-18	1N5818X/NBP	6.4-32	1N5938B	5.2-18
1N5361B	5.2-18	1N5819	5.6-6	1N5939B	5.2-18
1N5362B	5.2-18	1N5819X/NBP	6.4-32	1N5940B	5.2-18
1N5363B	5.2-18	1N5820	5.6-6	1N5941B	5.2-18
1N5364B	5.2-18	1N5821	5.6-6	1N5942B	5.2-18
1N5365B	5.2-18	1N5822	5.6-6	1N5943B	5.2-18
1N5366B	5.2-18	1N5822B/NBP	6.4-32	1N5944B	5.2-18
1N5367B	5.2-18	1N5823	5.6-6	1N5945B	5.2-18
1N5368B	5.2-18	1N5823X/NBP	6.4-32	1N5946B	5.2-19
1N5369B	5.2-18	1N5824	5.6-6	1N5947B	5.2-19
1N5370B	5.2-18	1N5825	5.6-6	1N5948B	5.2-19
1N5371B	5.2-18	1N5825B/NBP	6.4-32	1N5949B	5.2-19
1N5372B	5.2-18	1N5826	5.6-9	1N5950B	5.2-19
1N5373B	5.2-18	1N5827	5.6-9	1N5951B	5.2-19
1N5374B	5.2-19	1N5828	5.6-9	1N5952B	5.2-19
1N5375B	5.2-19	1N5829	5.6-9	1N5953B	5.2-19
1N5376B	5.2-19	1N5830	5.6-9	1N5954B	5.2-19
1N5377B	5.2-19	1N5831	5.6-9	1N5955B	5.2-19
1N5378B	5.2-19	1N5832	5.6-9	1N5956B	5.2-19
1N5379B	5.2-19	1N5833	5.6-9	1N5985B	5.2-16
1N5380B	5.2-19	1N5834	5.6-9	1N5986B	5.2-16
1N5381B	5.2-19	1N5908	5.2-6	1N5987B	5.2-16
1N5382B	5.2-19	1N5913B	5.2-18	1N5988B	5.2-16
1N5383B	5.2-19	1N5914B	5.2-18	1N5989B	5.2-16
1N5384B	5.2-19	1N5915B	5.2-18	1N5990B	5.2-16
1N5385B	5.2-19	1N5916B	5.2-18	1N5991B	5.2-16
1N5386B	5.2-19	1N5917B	5.2-18	1N5992B	5.2-16
1N5387B	5.2-19	1N5918B	5.2-18	1N5993B	5.2-16

# Device Index

1N5994B	5.2-16	1N6277A	5.2-7, 5.2-13	1N749A	5.2-16
1N5995B	5.2-16	1N6278A	5.2-7, 5.2-13	1N750A	5.2-16
1N5996B	5.2-16	1N6279A	5.2-7, 5.2-13	1N751A	5.2-16
1N5997B	5.2-16	1N6280A	5.2-7, 5.2-13	1N752A	5.2-16
1N5998B	5.2-16	1N6281A	5.2-7, 5.2-13	1N753A	5.2-16
1N5999B	5.2-16	1N6282A	5.2-7, 5.2-13	1N754A	5.2-16
1N6000B	5.2-16	1N6283A	5.2-7, 5.2-13	1N755A	5.2-16
1N6001B	5.2-16	1N6284A	5.2-7, 5.2-13	1N756A	5.2-16
1N6002B	5.2-16	1N6285A	5.2-7, 5.2-13	1N757A	5.2-16
1N6003B	5.2-16	1N6286A	5.2-7, 5.2-13	1N758A	5.2-16
1N6004B	5.2-16	1N6287A	5.2-7, 5.2-13	1N759A	5.2-16
1N6005B	5.2-16	1N6288A	5.2-7, 5.2-13	1N821	5.2-31
1N6006B	5.2-16	1N6289A	5.2-7, 5.2-13	1N821A	5.2-31
1N6007B	5.2-17	1N6290A	5.2-7, 5.2-13	1N821AX/NBP	6.4-32
1N6008B	5.2-17	1N6291A	5.2-7, 5.2-13	1N823	5.2-31
1N6009B	5.2-17	1N6292A	5.2-7, 5.2-13	1N823A	5.2-31
1N6010B	5.2-17	1N6293A	5.2-7, 5.2-13	1N823AX/NBP	6.4-32
1N6011B	5.2-17	1N6294A	5.2-7, 5.2-13	1N825	5.2-31
1N6012B	5.2-17	1N6295A	5.2-7, 5.2-13	1N825A	5.2-31
1N6013B	5.2-17	1N6296A	5.2-7, 5.2-13	1N825AA/NBP	6.4-32
1N6014B	5.2-17	1N6297A	5.2-7, 5.2-13	1N825AX/NBP	6.4-32
1N6015B	5.2-17	1N6298A	5.2-7, 5.2-13	1N827	5.2-31
1N6016B	5.2-17	1N6299A	5.2-8, 5.2-13	1N827A	5.2-31
1N6017B	5.2-17	1N6300A	5.2-8, 5.2-13	1N827AX/NBP	6.4-32
1N6018B	5.2-17	1N6301A	5.2-8, 5.2-13	1N829	5.2-31
1N6019B	5.2-17	1N6302A	5.2-8, 5.2-13	1N829A	5.2-31
1N6020B	5.2-17	1N6303A	5.2-8, 5.2-13	1N829AX/NBP	6.4-32
1N6021B	5.2-17	1N6373	5.2-6	1N914	4.8-25
1N6022B	5.2-17	1N6374	5.2-6	1N957B	5.2-16
1N6023B	5.2-17	1N6375	5.2-6	1N958B	5.2-16
1N6024B	5.2-17	1N6376	5.2-6	1N959B	5.2-16
1N6025B	5.2-17	1N6377	5.2-6	1N960B	5.2-16
1N6095	5.6-9	1N6378	5.2-6	1N961B	5.2-16
1N6096	5.6-9	1N6379	5.2-6	1N962B	5.2-16
1N6096X/NBP	6.4-32	1N6380	5.2-6	1N963B	5.2-16
1N6097	5.6-9	1N6381	5.2-6	1N964B	5.2-16
1N6098	5.6-9	1N6382	5.2-6	1N965B	5.2-16
1N6267A	5.2-7, 5.2-13	1N6383	5.2-6	1N966B	5.2-16
1N6268A	5.2-7, 5.2-13	1N6384	5.2-6	1N967B	5.2-16
1N6269A	5.2-7, 5.2-13	1N6385	5.2-6	1N968B	5.2-17
1N6270A	5.2-7, 5.2-13	1N6386	5.2-6	1N969B	5.2-17
1N6271A	5.2-7, 5.2-13	1N6387	5.2-6	1N970B	5.2-17
1N6272A	5.2-7, 5.2-13	1N6388	5.2-6	1N971B	5.2-17
1N6273A	5.2-7, 5.2-13	1N6389	5.2-6	1N972B	5.2-17
1N6274A	5.2-7, 5.2-13	1N746A	5.2-16	1N973B	5.2-17
1N6275A	5.2-7, 5.2-13	1N747A	5.2-16	1N974B	5.2-17
1N6276A	5.2-7, 5.2-13	1N748A	5.2-16	1N975B	5.2-17

# Device Index

1N976B	5.2-17	1SMB24CAT3	5.2-10	1SMB5934BT3	5.2-21
1N977B	5.2-17	1SMB26AT3	5.2-10	1SMB5935BT3	5.2-21
1N978B	5.2-17	1SMB26CAT3	5.2-10	1SMB5936BT3	5.2-22
1N979B	5.2-17	1SMB28AT3	5.2-10	1SMB5937BT3	5.2-22
1N980B	5.2-17	1SMB28CAT3	5.2-10	1SMB5938BT3	5.2-22
1N981B	5.2-17	1SMB30AT3	5.2-10	1SMB5939BT3	5.2-22
1N982B	5.2-17	1SMB30CAT3	5.2-10	1SMB5940BT3	5.2-22
1N983B	5.2-17	1SMB33AT3	5.2-10	1SMB5941BT3	5.2-22
1N984B	5.2-17	1SMB33CAT3	5.2-10	1SMB5942BT3	5.2-22
1N985B	5.2-17	1SMB36AT3	5.2-10	1SMB5943BT3	5.2-22
1N986B	5.2-17	1SMB36CAT3	5.2-10	1SMB5944BT3	5.2-22
1N987B	5.2-17	1SMB40AT3	5.2-10	1SMB5945BT3	5.2-22
1N988B	5.2-17	1SMB40CAT3	5.2-10	1SMB5946BT3	5.2-22
1N989B	5.2-17	1SMB43AT3	5.2-10	1SMB5947BT3	5.2-22
1N990B	5.2-17	1SMB43CAT3	5.2-10	1SMB5948BT3	5.2-22
1N991B	5.2-17	1SMB45AT3	5.2-10	1SMB5949BT3	5.2-22
1N992B	5.2-17	1SMB45CAT3	5.2-10	1SMB5950BT3	5.2-22
1SMB10AT3	5.2-10	1SMB48AT3	5.2-10	1SMB5951BT3	5.2-22
1SMB10CAT3	5.2-10	1SMB48CAT3	5.2-10	1SMB5952BT3	5.2-22
1SMB100AT3	5.2-11	1SMB5.0AT3	5.2-10	1SMB5953BT3	5.2-22
1SMB11AT3	5.2-10	1SMB51AT3	5.2-10	1SMB5954BT3	5.2-22
1SMB11CAT3	5.2-10	1SMB51CAT3	5.2-10	1SMB5955BT3	5.2-22
1SMB110AT3	5.2-11	1SMB54AT3	5.2-10	1SMB5956BT3	5.2-22
1SMB12AT3	5.2-10	1SMB54CAT3	5.2-10	1SMB6.0AT3	5.2-10
1SMB12CAT3	5.2-10	1SMB58AT3	5.2-10	1SMB6.5AT3	5.2-10
1SMB120AT3	5.2-11	1SMB58CAT3	5.2-10	1SMB60AT3	5.2-10
1SMB13AT3	5.2-10	1SMB5913BT3	5.2-21	1SMB60CAT3	5.2-10
1SMB13CAT3	5.2-10	1SMB5914BT3	5.2-21	1SMB64AT3	5.2-10
1SMB130AT3	5.2-11	1SMB5915BT3	5.2-21	1SMB64CAT3	5.2-10
1SMB14AT3	5.2-10	1SMB5916BT3	5.2-21	1SMB7.0AT3	5.2-10
1SMB14CAT3	5.2-10	1SMB5917BT3	5.2-21	1SMB7.5AT3	5.2-10
1SMB15AT3	5.2-10	1SMB5918BT3	5.2-21	1SMB70AT3	5.2-10
1SMB15CAT3	5.2-10	1SMB5919BT3	5.2-21	1SMB70CAT3	5.2-10
1SMB150AT3	5.2-11	1SMB5920BT3	5.2-21	1SMB75AT3	5.2-10
1SMB16AT3	5.2-10	1SMB5921BT3	5.2-21	1SMB75CAT3	5.2-10
1SMB16CAT3	5.2-10	1SMB5922BT3	5.2-21	1SMB78AT3	5.2-11
1SMB160AT3	5.2-11	1SMB5923BT3	5.2-21	1SMB78CAT3	5.2-11
1SMB17AT3	5.2-10	1SMB5924BT3	5.2-21	1SMB8.0AT3	5.2-10
1SMB17CAT3	5.2-10	1SMB5925BT3	5.2-21	1SMB8.5AT3	5.2-10
1SMB170AT3	5.2-11	1SMB5926BT3	5.2-21	1SMB85AT3	5.2-11
1SMB18AT3	5.2-10	1SMB5927BT3	5.2-21	1SMB9.0AT3	5.2-10
1SMB18CAT3	5.2-10	1SMB5928BT3	5.2-21	1SMB90AT3	5.2-11
1SMB20AT3	5.2-10	1SMB5929BT3	5.2-21	1SMC10AT3	5.2-14
1SMB20CAT3	5.2-10	1SMB5930BT3	5.2-21	1SMC11AT3	5.2-14
1SMB22AT3	5.2-10	1SMB5931BT3	5.2-21	1SMC12AT3	5.2-14
1SMB22CAT3	5.2-10	1SMB5932BT3	5.2-21	1SMC13AT3	5.2-14
1SMB24AT3	5.2-10	1SMB5933BT3	5.2-21	1SMC14AT3	5.2-14



# Device Index

1SMC15AT3	5.2-14	10E507	6.2-5	10H751	6.2-10
1SMC16AT3	5.2-14	10E511	6.2-5	100ELT20	6.2-6
1SMC17AT3	5.2-14	10E516	6.2-5	100ELT21	6.2-6
1SMC18AT3	5.2-14	10E531	6.2-5	100ELT22	6.2-6
1SMC20AT3	5.2-14	10E541	6.2-5	100ELT23	6.2-6
1SMC22AT3	5.2-14	10E551	6.2-5	100ELT24	6.2-6
1SMC24AT3	5.2-14	10E595	6.2-5	100ELT25	6.2-6
1SMC26AT3	5.2-14	10E851	6.2-6	100ELT26	6.2-6
1SMC28AT3	5.2-14	10H1042	6.2-10	100ELT28	6.2-6
1SMC30AT3	5.2-14	10H416	6.2-9	100EL01	6.2-6
1SMC33AT3	5.2-14	10H500	6.2-9	100EL04	6.2-6
1SMC36AT3	5.2-14	10H501	6.2-9	100EL05	6.2-6
1SMC40AT3	5.2-14	10H502	6.2-9	100EL07	6.2-6
1SMC43AT3	5.2-14	10H503	6.2-9	100EL11	6.2-6
1SMC45AT3	5.2-14	10H504	6.2-9	100EL12	6.2-6
1SMC48AT3	5.2-14	10H505	6.2-9	100EL15	6.2-6
1SMC5.0AT3	5.2-14	10H506	6.2-9	100EL16	6.2-6
1SMC51AT3	5.2-14	10H507	6.2-9	100EL31	6.2-6
1SMC54AT3	5.2-14	10H509	6.2-9	100EL32	6.2-6
1SMC58AT3	5.2-14	10H513	6.2-9	100EL33	6.2-6
1SMC6.0AT3	5.2-14	10H515	6.2-9	100EL34	6.2-6
1SMC6.5AT3	5.2-14	10H516	6.2-9	100EL35	6.2-6
1SMC60AT3	5.2-14	10H517	6.2-9	100EL51	6.2-6
1SMC64AT3	5.2-14	10H518	6.2-9	100EL52	6.2-6
1SMC7.0AT3	5.2-14	10H519	6.2-9	100EL57	6.2-6
1SMC7.5AT3	5.2-14	10H521	6.2-9	100EL58	6.2-6
1SMC70AT3	5.2-14	10H524	6.2-9	100E416	6.2-5
1SMC75AT3	5.2-14	10H525	6.2-9	100E501	6.2-5
1SMC78AT3	5.2-14	10H531	6.2-9	100E504	6.2-5
1SMC8.0AT3	5.2-14	10H535	6.2-9	100E507	6.2-5
1SMC8.5AT3	5.2-14	10H536	6.2-9	100E511	6.2-5
1SMC9.0AT3	5.2-14	10H541	6.2-9	100E516	6.2-5
10ELT20	6.2-6	10H558	6.2-9	100E531	6.2-5
10ELT21	6.2-6	10H560	6.2-9	100E541	6.2-5
10ELT22	6.2-6	10H561	6.2-9	100E551	6.2-5
10ELT23	6.2-6	10H562	6.2-9	100E595	6.2-5
10ELT24	6.2-6	10H564	6.2-9	100E851	6.2-5
10ELT25	6.2-6	10H571	6.2-9	100H1042	6.2-10
10ELT26	6.2-6	10H574	6.2-9	101A/YBCMAQ	6.4-24
10ELT28	6.2-6	10H576	6.2-9	101A/YBDGAQ	6.4-24
10ELT34	6.2-6	10H581	6.2-9	10319	6.2-2
10ELT35	6.2-6	10H586	6.2-9	10500	6.2-7
10ELT57	6.2-6	10H588	6.2-9	10501	6.2-7
10EL15	6.2-6	10H589	6.2-9	10502	6.2-7
10E416	6.2-5	10H609	6.2-9	10503	6.2-7
10E501	6.2-5	10H610	6.2-9	10504	6.2-7
10E504	6.2-5	10H750	6.2-10	10505	6.2-7

# Device Index

10506	6.2-7	10578	6.2-8	14001B	6.2-17
10507	6.2-7	10579	6.2-8	14002A	6.2-17
10509	6.2-7	10580	6.2-8	14007A	6.2-17
10513	6.2-7	10581	6.2-8	14011A	6.2-17
10514	6.2-7	10582	6.2-8	14011B	6.2-17
10515	6.2-7	10586	6.2-8	14012B	6.2-17
10516	6.2-7	10590	6.2-8	14013B	6.2-17
10517	6.2-7	10591	6.2-8	14014B	6.2-17
10518	6.2-7	10592	6.2-8	14015B	6.2-17
10519	6.2-7	10593	6.2-8	14016B	6.2-17
10521	6.2-7	10595	6.2-8	14017B	6.2-17
10523	6.2-7	10597	6.2-8	14018B	6.2-17
10524	6.2-7	10598	6.2-8	14020B	6.2-17
10525	6.2-7	10610	6.2-8	14021B	6.2-18
10530	6.2-7	10611	6.2-8	14023A	6.2-20
10531	6.2-7	10612	6.2-8	14023B	6.2-20
10533	6.2-7	10616	6.2-8	14024B	6.2-20
10535	6.2-7	10631	6.2-8	14025A	6.2-20
10536	6.2-7	108	6.2-2	14025B	6.2-20
10537	6.2-7	108/YBCMAQ	6.4-24	14027B	6.2-20
10538	6.2-7	108/YBDGAQ	6.4-24	14028B	6.2-20
10539	6.2-20	108A	6.2-2	14029B	6.2-20
10539	6.2-7	108A/YBCMAQ	6.4-24	14040B	6.2-18
10541	6.2-7	108A/YBDGAQ	6.4-24	14042B	6.2-18
10545	6.2-22	111	6.2-2	14043B	6.2-18
10545	6.2-7	111/YBCMAQ	6.4-24	14044B	6.2-18
10549	6.2-20	111/YBDGAQ	6.4-24	14046B	6.2-18
10549	6.2-7	117/YBCMAQ	6.4-24	14049A	6.2-18
10552	6.2-20	117/YBKMAQ	6.4-24	14050B	6.2-18
10552	6.2-7	123/NBKMAP	6.4-25	14051B	6.2-18
10553	6.2-7	124	6.2-2	14052B	6.2-18
10558	6.2-7	124/YBDGAQ	6.4-24	14053B	6.2-18
10560	6.2-7	12502	6.2-10	14066B	6.2-18
10561	6.2-7	12509	6.2-10	14069A	6.2-18
10562	6.2-7	12511	6.2-10	14070B	6.2-18
10563	6.2-8	12513	6.2-10	14071B	6.2-18
10564	6.2-8	12514	6.2-10	14072B	6.2-18
10565	6.2-8	12515	6.2-10	14073B	6.2-18
10566	6.2-8	12540	6.2-10	14075B	6.2-18
10568	6.2-8	12561	6.2-10	14076B	6.2-18
10570	6.2-8	137/YBCMAQ	6.4-24	14081B	6.2-18
10571	6.2-8	137/YBKMAQ	6.4-24	14082B	6.2-18
10572	6.2-8	139	6.2-2	14093B	6.2-18
10573	6.2-8	139/YBDGAQ	6.4-24	14094B	6.2-18
10574	6.2-8	139A	6.2-2	14099B	6.2-18
10575	6.2-8	139A/YBDGAQ	6.4-24	14161B	6.2-18
10576	6.2-8	14001A	6.2-17	14174B	6.2-18

# Device Index

14175B	6.2-18	1545	6.2-2	1741S	6.2-3
14490A	6.2-18	155/YBCMAQ	6.4-24	1741S/NBCMAP	6.4-25
14502B	6.2-18	155A/YBCMAQ	6.4-24	1747	6.2-3
14503B	6.2-18	1550	6.2-2	1748/NBCMAP	6.4-25
14504B	6.2-18	1554	6.2-2	1748/NBDGAP	6.4-26
14511B	6.2-18	1555	6.2-2	188100	6.2-33
14512B	6.2-18	1555/NBCMAP	6.4-25	193	6.2-3
145146-2	6.2-4	1555/NBDGAP	6.4-25	193/YBCMAQ	6.4-25
145151-2	6.2-4	1556	6.2-2	193A	6.2-3
145152-2	6.2-4	1558	6.2-2	193A/YBCMAQ	6.4-25
145155-2	6.2-4	1558/YBCMAQ	6.4-25	196002	6.2-33
145156-2	6.2-4	1558/YBDGAQ	6.4-25	2C2222AHV	6.3-21
145157-2	6.2-4	1558S	6.2-2	2C2369AHV	6.3-21
145158-2	6.2-4	156/YBCMAQ	6.4-24	2C2484HV	6.3-21
14517B	6.2-19	156A/YBCMAQ	6.4-25	2C2605HV	6.3-21
14518B	6.2-19	1563	6.2-2	2C2857HV	6.3-22
14519B	6.2-19	1568	6.2-2	2C2907AHV	6.3-21
145190	6.2-4	1569	6.2-2	2C3019HV	6.3-21
145191	6.2-4	157/YBCMAQ	6.4-25	2C3251AHV	6.3-21
145192	6.2-4	158	6.2-2	2C3439HV	6.3-21
14520B	6.2-19	158/YBCMAQ	6.4-25	2C3468HV	6.3-21
14532B	6.2-19	158/YBDGAQ	6.4-25	2C3501HV	6.3-21
14536B	6.2-19	1588/NBDGAP	6.4-25	2C3553HV	6.3-21
14538B	6.2-19	1589/NBDGAP	6.4-25	2C3716HV	6.3-21
14539B	6.2-19	1590	6.2-2	2C3741HV	6.3-21
145406-2	6.2-4	1590/NBCMAP	6.4-25	2C3767HV	6.3-21
145407-2	6.2-4	1594	6.2-2	2C3792HV	6.3-21
14541B	6.2-19	1595	6.2-2	2C3866AHV	6.3-21
14555B	6.2-19	1596	6.2-3	2C5109HV	6.3-22
14557B	6.2-19	1596/NBDGAP	6.4-25	2C5339HV	6.3-21
14572A	6.2-19	1596/NBPCCP	6.4-25	2C6052HV	6.3-21
14584B	6.2-19	1648M	6.2-10	2C6059HV	6.3-21
14585B	6.2-19	1650	6.2-10	2C6193HV	6.3-21
148/YBDGAQ	6.4-24	1651	6.2-10	2C918HV	6.3-21
1488	6.2-2	1654	6.2-10	2N1613B/FBQ	6.4-28
1489	6.2-2	1660	6.2-10	2N1711B/FBQ	6.4-28
1489A	6.2-2	1662	6.2-10	2N1893	5.1-17
1508	6.2-2	1664	6.2-10	2N1893B/FBQ	6.4-28
1513/NBDGAP	6.4-25	1670	6.2-10	2N2060	6.3-2, 6.3-10
1514/NBDGAP	6.4-25	1672	6.2-10	2N2102B/NBP	6.4-29
1525A/NBDGAP	6.4-25	1678	6.2-10	2N2218A	5.1-17
1526	6.2-2	1690	6.2-10	2N2218AB/FBQ	6.4-28
1526/NBDGAP	6.4-25	1692	6.2-10	2N2219A	6.3-2, 6.3-8, 6.4-28
1536	6.2-2	1709	6.2-3	2N2219A	5.1-17
1536/NBCMAP	6.4-25	1723	6.2-3	2N2219AA/FAQ	6.4-28
1537	6.2-2	1733	6.2-3	2N2219AA/FBQ	6.4-28
1539	6.2-2	1741	6.2-3	2N2219AB/FBQ	6.4-28

8

# Device Index

2N2222	6.3-2, 6.3-5, 6.3-8	2N3440	6.3-2, 6.3-10, 6.4-28	2N3739	6.3-2, 6.3-7
2N2222A	6.3-2, 6.3-8, 6.4-28	2N3440B/FBQ	6.4-28	2N3740	6.3-2, 6.3-7
2N2222A	5.1-17	2N3441A/NBP	6.4-29	2N3740A/NBP	6.4-29
2N2222AA/FBQ	6.4-28	2N3442	5.5-14	2N3741	6.3-2, 6.3-7
2N2222AB/FAQ	6.4-28	2N3442A/NBP	6.4-29	2N3741A/NBP	6.4-29
2N2222AB/FBQ	6.4-28	2N3467	6.3-2, 6.3-9	2N3743	6.3-3, 6.3-10
2N2369A	6.3-2, 6.3-5, 6.3-9	2N3467	5.1-19	2N3764	6.3-3, 6.3-9
2N2369A	5.1-19	2N3468	6.3-5	2N3766	6.3-3, 6.3-7
2N2369AB/FBQ	6.4-28	2N3468	5.1-19	2N3767	6.3-3, 6.3-7
2N2484	6.3-2, 6.3-5, 6.3-8	2N3486A	6.3-2, 6.3-8	2N3767A/NBP	6.4-29
2N2484	5.1-18	2N3497	5.1-18	2N3771	6.3-3
2N2605	6.3-2, 6.3-5, 6.3-8	2N3499	6.4-28	2N3771	5.5-16
2N2609	6.3-2	2N3500	5.1-18	2N3772	6.3-3
2N2857	6.3-5	2N3501	6.3-2, 6.3-10	2N3772	5.5-15
2N2904	6.3-2, 6.3-8		6.4-28	2N3773	5.5-15
2N2904A	5.1-17	2N3501	5.1-18	2N3791	5.5-14
2N2905A	6.3-2, 6.3-8, 6.4-28	2N3501B/NBP	6.4-29	2N3791A/NBP	6.4-29
2N2905A	5.1-17	2N3506	6.3-2, 6.3-9	2N3792	6.3-3, 6.3-6
2N2905AA/FBQ	6.4-28	2N3507	6.3-2, 6.3-9	2N3792	5.5-14
2N2905AB/FBQ	6.4-28	2N3546	5.1-19	2N3799	5.1-18
2N2906A	6.3-2, 6.3-8	2N3553X/NBP	6.4-31	2N3810	6.3-3, 6.3-10
2N2906A	5.1-17	2N3584	6.3-2	2N3810B/NBP	6.4-30
2N2907	6.3-2, 6.3-5, 6.3-8	2N3585	6.3-2	2N3811	6.3-3, 6.3-10
2N2907A	6.3-2, 6.3-8	2N3585A/NBP	6.4-29	2N3811B/NBP	6.4-30
	6.4-28	2N3634	6.3-2, 6.3-9	2N3819	6.3-10
2N2907A	5.1-17		6.3-10	2N3820	6.3-10
2N2907AA/FBQ	6.4-28	2N3634B/NBP	6.4-29	2N3821	6.3-3, 6.3-11
2N2907AB/FAQ	6.4-28	2N3635	6.3-9, 6.3-10	2N3821X/NBP	6.4-30
2N2907AB/FBQ	6.4-28	2N3636	6.3-2, 6.3-9	2N3866A	6.3-5
2N2919B/NBP	6.4-29		6.3-10, 6.4-28	2N3867S	6.3-3, 6.3-7
2N2920	6.3-2	2N3636	5.1-18	2N3868S	6.3-3, 6.3-7
2N2920B/NBP	6.4-29	2N3637	6.3-2, 6.3-9	2N3879	6.3-3
2N3013	6.3-2, 6.3-9		6.3-10, 6.4-28	2N3903	5.1-2
2N3019	5.1-17	2N3637	5.1-18	2N3904	5.1-2
2N3019B/FBQ	6.4-28	2N3637B/NBP	6.4-29	2N3905	5.1-2
2N3019S	6.3-2, 6.3-8	2N3700	6.3-2, 6.3-8	2N3906	5.1-2
2N3020	5.1-17	2N3700	5.1-17	2N3947	5.1-17
2N3054A/NBP	6.4-29	2N3700B/NBP	6.4-29	2N3964	5.1-18
2N3055	5.5-14	2N3715	6.3-2, 6.3-6	2N3964B/NBP	6.4-29
2N3055A	5.5-14, 5.5-18	2N3715	5.5-14	2N4014	5.1-19
2N3055A/NBP	6.4-29	2N3715A/NBP	6.4-29	2N4032	5.1-17
2N3055AA/NBP	6.4-29	2N3716	6.3-2, 6.3-6	2N4033	6.3-3, 6.3-8, 6.3-9
2N3251A	6.3-2, 6.3-5, 6.3-8	2N3716	5.5-14	2N4033	5.1-17
2N3251A	5.1-17	2N3716A/NBP	6.4-29	2N4036	5.1-17
2N3439	6.3-2, 6.3-10	2N3735	6.3-2, 6.3-9	2N4036B/NBP	6.4-29
	6.4-28	2N3737	6.3-2, 6.3-9	2N4091B/NBP	6.4-29
2N3439B/FBQ	6.4-28	2N3738A/NBP	6.4-29	2N4092B/NBP	6.4-29

# Device Index

2N4123	5.1-2	2N5062	5.7-2	2N5680B/NBP	6.4-29
2N4124	5.1-2	2N5064	5.7-2	2N5682B/NBP	6.4-29
2N4125	5.1-2	2N5086	5.1-3	2N5683	6.3-3
2N4126	5.1-2	2N5087	5.1-3	2N5683	5.5-16
2N4236B/NBP	6.4-29	2N5088	5.1-3	2N5683	6.3-6
2N4261	6.3-3, 6.3-9	2N5089	5.1-3	2N5684	6.3-3
2N4261X/NBP	6.4-29	2N5109	6.3-5	2N5684	5.5-16
2N4264	5.1-6	2N5109B/NBP	6.4-31	2N5684	6.3-6
2N4265	5.1-6	2N5191	5.5-11	2N5685	6.3-3, 6.3-6
2N4392B/NBP	6.4-30	2N5192	5.5-11	2N5685	5.5-16
2N4398	5.5-16	2N5194	5.5-11	2N5686	6.3-3
2N4399	6.3-3, 6.3-6	2N5195	5.5-11	2N5686	5.5-16
2N4399	5.5-16	2N5301	5.5-16	2N5686	6.3-6
2N4400	5.1-2	2N5302	6.3-3, 6.3-6	2N5745	6.3-3, 6.3-6
2N4401	5.1-2	2N5302	5.5-16	2N5745	5.5-15
2N4402	5.1-2	2N5303	6.3-3, 6.3-6	2N5758	5.5-13
2N4403	5.1-2	2N5303	5.5-15	2N5794	6.3-4, 6.3-10
2N4405	6.3-3, 6.3-8, 6.3-9	2N5322B/NBP	6.4-29	2N5796	6.3-4, 6.3-10
2N4410	5.1-2	2N5339	6.3-3, 6.3-7	2N5875	5.5-14
2N4416A	6.3-3, 6.3-11	2N5401	5.1-5	2N5876	5.5-14
2N4416AX/NBP	6.4-30	2N5415B/FBQ	6.4-28	2N5877	5.5-14
2N4416X/NBP	6.4-30	2N5416B/FBQ	6.4-28	2N5878	5.5-14
2N4449	6.3-3, 6.3-9	2N5416S	6.3-3, 6.3-10	2N5879	5.5-14
2N4854	6.3-3, 6.3-10	2N5457	5.1-20	2N5880	5.5-14
2N4856	6.3-3, 6.3-11	2N5458	5.1-20	2N5881	5.5-14
2N4857	6.3-3, 6.3-11	2N5459	5.1-20	2N5882	5.5-14
2N4857B/NBP	6.4-30	2N5460	5.1-20	2N5883	5.5-16
2N4858	6.3-3, 6.3-11	2N5461	5.1-20	2N5884	5.5-16
2N4860A/NBP	6.4-29	2N5462	5.1-20	2N5884A/NBP	6.4-29
2N4860B/NBP	6.4-29	2N5484	5.1-20	2N5885	5.5-16
2N4912A/NBP	6.4-29	2N5485	5.1-20	2N5886	5.5-16
2N4918	5.5-11	2N5486	5.1-20	2N5886A/NBP	6.4-29
2N4919	5.5-11	2N5551	5.1-5	2N6027	5.7-17
2N4920	5.5-11	2N5555	5.1-21	2N6028	5.7-17
2N4921	5.5-11	2N5582	6.3-3, 6.3-8	2N6030	5.5-15
2N4922	5.5-11	2N5583	6.3-5	2N6031	5.5-15
2N4923	5.5-11	2N5583X/NBP	6.4-31	2N6035	5.5-11
2N4927	5.1-18	2N5630	5.5-15	2N6036	5.5-12
2N4931	6.3-3, 6.3-10	2N5631	5.5-15	2N6038	5.5-11
2N4931	5.1-18	2N5639	5.1-21	2N6039	5.5-12
2N4957	6.3-5	2N5640	5.1-21	2N6040	5.5-6
2N5038	6.3-3, 6.3-6	2N5655	5.5-10	2N6041	5.5-6
2N5038	5.5-15	2N5656	5.5-10	2N6042	5.5-6
2N5039	6.3-3, 6.3-6	2N5657	5.5-11	2N6043	5.5-6
2N5039	5.5-15	2N5668	5.1-20	2N6044	5.5-6
2N5060	5.7-2	2N5669	5.1-20	2N6045	5.5-6
2N5061	5.7-2	2N5670	5.1-20	2N6050	5.5-14

# Device Index

2N6051	6.3-4, 6.3-6	2N6284	6.3-4, 6.3-6	2N6379	5.5-16
2N6051	5.5-14	2N6284	5.5-15	2N6379	6.3-6
2N6052	6.3-4, 6.3-6	2N6284A/NBP	6.4-30	2N6385	6.3-4, 6.3-6
2N6052	5.5-14	2N6285	5.5-15	2N6387	5.5-6
2N6052A/NBP	6.4-29	2N6286	6.3-4, 6.3-6	2N6388	5.5-6
2N6053	5.5-13	2N6286	5.5-15	2N6394	5.7-5
2N6054	5.5-13	2N6287	6.3-4, 6.3-6	2N6395	5.7-5
2N6055	5.5-13	2N6287	5.5-15	2N6396	5.7-5
2N6056	5.5-13	2N6287A/NBP	6.4-30	2N6397	5.7-5
2N6057	5.5-14	2N6288	5.5-5	2N6398	5.7-5
2N6058	6.3-4, 6.3-6	2N6292	5.5-5	2N6399	5.7-5
2N6058	5.5-14	2N6298	6.3-4, 6.3-7	2N6400	5.7-5
2N6059	6.3-4, 6.3-6	2N6299	6.3-4, 6.3-7	2N6401	5.7-5
2N6059	5.5-14	2N6300	6.3-4, 6.3-7	2N6402	5.7-5
2N6059A/NBP	6.4-30	2N6301	6.3-4, 6.3-7	2N6403	5.7-5
2N6071	5.7-8	2N6306	6.3-4, 6.3-6	2N6404	5.7-5
2N6071A	5.7-8	2N6308	6.3-4, 6.3-6	2N6405	5.7-5
2N6071B	5.7-8	2N6316	6.3-5	2N6426	5.1-4
2N6073	5.7-8	2N6317A/NBP	6.4-30	2N6427	5.1-4
2N6073A	5.7-8	2N6318	6.3-5	2N6431	5.1-18
2N6073B	5.7-8	2N6328	5.5-16	2N6433	5.1-18
2N6075	5.7-8	2N6338	6.3-4	2N6436	5.5-16
2N6075A	5.7-8	2N6338	5.5-16	2N6437	6.3-4, 6.3-6
2N6075B	5.7-8	2N6339	5.5-16	2N6437	5.5-16
2N6107	5.5-5	2N6340	5.5-16	2N6438	6.3-4, 6.3-6
2N6109	5.5-5	2N6341	6.3-4	2N6438	5.5-16
2N6111	5.5-5	2N6341	5.5-16	2N6439	5.10-7
2N6193	6.3-4, 6.3-7	2N6342	5.7-10	2N6487	5.5-7
2N6211	6.3-4	2N6342A	5.7-13	2N6488	5.5-7
2N6212	6.3-4	2N6343	5.7-10	2N6490	5.5-7
2N6213	6.3-4	2N6343A	5.7-13	2N6491	5.5-7
2N6233A/NBP	6.4-30	2N6344	5.7-10	2N6497	5.5-5
2N6237	5.7-3	2N6344A	5.7-13	2N6498	5.5-5
2N6238	5.7-3	2N6345	5.7-10	2N6504	5.7-5
2N6239	5.7-3	2N6345A	5.7-13	2N6505	5.7-5
2N6240	5.7-3	2N6346	5.7-10	2N6506	5.7-5
2N6241	5.7-3	2N6346A	5.7-13	2N6507	5.7-5
2N6251	5.5-15	2N6347	5.7-10	2N6508	5.7-5
2N6274	6.3-4	2N6347A	5.7-13	2N6509	5.7-5
2N6274	5.5-16	2N6348	5.7-10	2N6517	5.1-5
2N6274	6.3-6	2N6348A	5.7-13	2N6519	5.1-5
2N6275	5.5-16	2N6349	5.7-10	2N6520	5.1-5
2N6277	5.5-17	2N6349A	5.7-13	2N6546	6.3-4, 6.3-6
2N6277	6.3-4, 6.3-6	2N6378	6.3-4	2N6547	6.3-4, 6.3-6
2N6282	5.5-15	2N6378	5.5-16	2N6547	5.5-15
2N6283	6.3-4, 6.3-6	2N6378	6.3-6	2N6576	5.5-14
2N6283	5.5-15	2N6379	6.3-4	2N6577	5.5-14

# Device Index

2N6578	5.5-14	3EZ16D5	5.2-18	35063	6.2-3
2N6603	6.3-5	3EZ160D5	5.2-19	35074	6.2-3
2N6604	6.3-5	3EZ17D5	5.2-18	35074/NBDGAP	6.4-26
2N6609	5.5-15	3EZ170D5	5.2-19	35074A	6.2-3
2N6609A/NBP	6.4-30	3EZ18D5	5.2-18	35102	6.2-3
2N6650	6.3-4, 6.3-6	3EZ180D5	5.2-19	35161	6.2-3
2N6667	5.5-6	3EZ19D5	5.2-18	35164	6.2-3
2N6668	5.5-6	3EZ190D5	5.2-19	3517	6.2-3
2N6836	5.5-15	3EZ20D5	5.2-18	35174	6.2-3
2N6985	5.10-7	3EZ200D5	5.2-19	35179	6.2-3
2N6986	5.10-7	3EZ22D5	5.2-18	35204	6.2-3
2N6987	6.3-4, 6.3-10	3EZ220D5	5.2-19	3523	6.2-3
2N6988	6.3-4, 6.3-10	3EZ24D5	5.2-18	3523/NBDGAP	6.4-26
2N6988JTXV	6.3-17	3EZ240D5	5.2-19	35304	6.2-4
2N6989	6.3-4, 6.3-10	3EZ27D5	5.2-18	4N25	5.8-6
2N6990	6.3-4, 6.3-10	3EZ270D5	5.2-19	4N25A	5.8-6
2N6990JTXV	6.3-17	3EZ28D5	5.2-18	4N25AF	5.8-9
2N7000	5.1-22	3EZ3.9D5	5.2-18	4N25AS	5.8-9
2N7002LT1	5.1-24	3EZ30D5	5.2-18	4N25F	5.8-9
2N7008	5.1-22	3EZ300D5	5.2-19	4N25S	5.8-9
2N708	6.3-2, 6.3-9	3EZ33D5	5.2-18	4N25,A	5.8-6
2N720A	5.1-17	3EZ330D5	5.2-19	4N26	5.8-6
2N869A	6.3-2, 6.3-9	3EZ36D5	5.2-18	4N26F	5.8-9
2N914	6.3-9	3EZ360D5	5.2-19	4N26S	5.8-9
2N918	6.3-2, 6.3-5, 6.3-9	3EZ39D5	5.2-18	4N27	5.8-6
2N930	6.3-2, 6.3-8	3EZ4.3D5	5.2-18	4N27F	5.8-9
2N930	5.1-18	3EZ4.7D5	5.2-18	4N27S	5.8-9
2N930A	5.1-18	3EZ400D5	5.2-19	4N28	5.8-6
2N930B/NBP	6.4-29	3EZ43D5	5.2-18	4N28F	5.8-9
2003A	6.2-3	3EZ47D5	5.2-18	4N28S	5.8-9
22V10XXX	6.2-11, 6.2-13	3EZ5.1D5	5.2-18	4N29	5.8-7
26LS31	6.2-3	3EZ5.6D5	5.2-18	4N29A	5.8-7
26LS31C/YBDGAQ	6.4-24	3EZ51D5	5.2-18	4N29F	5.8-10
26LS32	6.2-3	3EZ56D5	5.2-18	4N29S	5.8-10
26LS32C/YBDGAQ	6.4-24	3EZ6.2D5	5.2-18	4N30	5.8-7
3EZ10D5	5.2-18	3EZ6.8D5	5.2-18	4N30F	5.8-10
3EZ100D5	5.2-19	3EZ62D5	5.2-18	4N30S	5.8-10
3EZ11D5	5.2-18	3EZ68D5	5.2-18	4N31	5.8-7
3EZ110D5	5.2-19	3EZ7.5D5	5.2-18	4N31F	5.8-10
3EZ12D5	5.2-18	3EZ75D5	5.2-19	4N31S	5.8-10
3EZ120D5	5.2-19	3EZ8.2D5	5.2-18	4N32	5.8-7
3EZ13D5	5.2-18	3EZ82D5	5.2-19	4N32A	5.8-7
3EZ130D5	5.2-19	3EZ9.1D5	5.2-18	4N32F	5.8-10
3EZ14D5	5.2-18	3EZ91D5	5.2-19	4N32S	5.8-10
3EZ140D5	5.2-19	3486/NBDGAP	6.4-26	4N33	5.8-7
3EZ15D5	5.2-18	35035	6.2-3	4N33F	5.8-10
3EZ150D5	5.2-19	35039	6.2-3	4N33S	5.8-10

# Device Index

4N35	5.8-6	4066BF/RBDQ	6.4-15	462110	6.2-29
4N35F	5.8-9	4068BF/RBDQ	6.4-15	46226	6.2-29
4N35S	5.8-9	4069UBF/RBDQ	6.4-15	4741/NBDGAP	6.4-26
4N36	5.8-6	4070BF/RBDQ	6.4-15	51L1000A11	6.2-22
4N36F	5.8-9	4071BF/RBDQ	6.4-15	51L1000A12	6.2-22
4N36S	5.8-9	4072BF/RBDQ	6.4-16	51L1000A8	6.2-21
4N37	5.8-6	4073BF/RBDQ	6.4-16	51L1000A9	6.2-21
4N37F	5.8-9	4075BF/RBDQ	6.4-16	51L4256A11	6.2-22
4N37S	5.8-9	4076BF/RBDQ	6.4-16	51L4256A12	6.2-22
4N38F	5.8-9	4077BF/RBDQ	6.4-16	51L4256A8	6.2-22
4N38S	5.8-9	4078BF/RBDQ	6.4-16	51L4256A9	6.2-22
4N38	5.8-6	4081BF/RBDQ	6.4-16	511000A11	6.2-21, 6.2-22, 6.2-24
4N38A	5.8-6	4082BF/RBDQ	6.4-16	511000A12	6.2-22
4001BF/RBDQ	6.4-15	4093BF/RBDQ	6.4-16	511000A8	6.2-21
4002BF/RBDQ	6.4-15	4094BF/RBDQ	6.4-16	511000A9	6.2-21, 6.2-22, 6.2-23
4006BF/RBDQ	6.4-15	4099BF/RBDQ	6.4-16	514256A11	6.2-22
4008BF/RBDQ	6.4-15	4161BF/RBDQ	6.4-16	514256A12	6.2-22
4011BF/RBDQ	6.4-15	4174BF/RBDQ	6.4-16	514256A8	6.2-22
4012BF/RBDQ	6.4-15	4175BF/RBDQ	6.4-16	514256A9	6.2-22
4013BF/RBDQ	6.4-15	431	6.2-4	514400A7	6.2-22
4014BF/RBDQ	6.4-15	4324	6.2-19	514400A8	6.2-22
4015BF/RBDQ	6.4-15	4344	6.2-19	514400A9	6.2-22
4016BF/RBDQ	6.4-15	4490BF/RBDQ	6.4-16	54ACT00/YBDGAQ	6.4-23
4017BF/RBDQ	6.4-15	4501UBF/RBDQ	6.4-16	54ACT02/YBDGAQ	6.4-23
4018BF/RBDQ	6.4-15	4502BF/RBDQ	6.4-16	54ACT04/YBDGAQ	6.4-23
4020BF/RBDQ	6.4-15	4503BF/RBDQ	6.4-16	54ACT08/YBDGAQ	6.4-23
4021BF/RBDQ	6.4-15	4504BF/RBDP	6.4-16	54ACT109/YBDGAQ	6.4-23
4022BF/RBDQ	6.4-15	4506UBF/RBDQ	6.4-16	54ACT11/YBDGAQ	6.4-23
4023BF/RBDQ	6.4-15	4510BF/RBDQ	6.4-16	54ACT138/YBDGAQ	6.4-23
4024BF/RBDQ	6.4-15	4511BF/RBDQ	6.4-16	54ACT139/YBDGAQ	6.4-23
4025BF/RBDQ	6.4-15	4512BF/RBDQ	6.4-16	54ACT14/YBDGAQ	6.4-23
4027BF/RBDQ	6.4-15	4516BF/RBDQ	6.4-16	54ACT151/YBDGAQ	6.4-23
4028BF/RBDQ	6.4-15	4517BF/RBDQ	6.4-16	54ACT157/YBDGAQ	6.4-23
4029BF/RBDQ	6.4-15	4518BF/RBDQ	6.4-16	54ACT161/YBDGAQ	6.4-23
4032BF/RBDQ	6.4-15	4519BF/RBDQ	6.4-16	54ACT163/YBDGAQ	6.4-24
4035BF/RBDQ	6.4-15	4521BF/RBDQ	6.4-16	54ACT244/YBDGAQ	6.4-24
4040BF/RBDQ	6.4-15	4526BF/RBDQ	6.4-16	54ACT245/YBDGAQ	6.4-24
4042BF/RBDQ	6.4-15	4527BF/RBDQ	6.4-16	54ACT257/YBDGAQ	6.4-24
4043BF/RBDQ	6.4-15	4528BF/RBDQ	6.4-16	54ACT32/YBDGAQ	6.4-23
4044BF/RBDQ	6.4-15	4531BF/RBDQ	6.4-16	54ACT373/YBDGAQ	6.4-24
4046BF/RBDP	6.4-15	4532BF/RBDQ	6.4-16	54ACT374/YBDGAQ	6.4-24
4049UBF/RBDQ	6.4-15	4536BF/RBDQ	6.4-16	54ACT564/YBDGAQ	6.4-24
4050BF/RBDQ	6.4-15	4538BF/RBDQ	6.4-16	54ACT74/YBDGAQ	6.4-23
4051BF/RBDQ	6.4-15	4541BF/RBDQ	6.4-16	54AC00/YBDGAQ	6.4-23
4052BF/RBDQ	6.4-15	4556BF/RBDQ	6.4-16	54AC02/YBDGAQ	6.4-23
4053BF/RBDQ	6.4-15	4584BF/RBDQ	6.4-16	54AC04/YBDGAQ	6.4-23
4060BF/RBDP	6.4-15	4585BF/RBDQ	6.4-16	54AC08/YBDGAQ	6.4-23



# Device Index

54AC10/YBDGAQ	6.4-23	54F161A/YBDGAQ	6.4-19	54F803	6.2-13
54AC109/YBDGAQ	6.4-23	54F163A/YBDGAQ	6.4-19	54F86	6.2-13
54AC11/YBDGAQ	6.4-23	54F174	6.2-12	54HCU04/YBDGAQ	6.4-18
54AC138/YBDGAQ	6.4-23	54F174/YBDGAQ	6.4-19	54HC00/YBDGAQ	6.4-17
54AC14/YBDGAQ	6.4-23	54F175	6.2-12	54HC02/YBDGAQ	6.4-17
54AC158/YBDGAQ	6.4-23	54F175/YBDGAQ	6.4-19	54HC03/YBDGAQ	6.4-17
54AC163/YBDGAQ	6.4-23	54F182	6.2-12	54HC04/YBDGAQ	6.4-17
54AC174/YBDGAQ	6.4-23	54F194	6.2-12	54HC08/YBDGAQ	6.4-17
54AC240/YBDGAQ	6.4-23	54F20	6.2-12	54HC10/YBDGAQ	6.4-17
54AC244/YBDGAQ	6.4-23	54F20/YBDGAQ	6.4-19	54HC107/YBDGAQ	6.4-17
54AC245/YBDGAQ	6.4-23	54F240	6.2-12	54HC109/YBDGAQ	6.4-17
54AC273/YBDGAQ	6.4-23	54F240/YBDGAQ	6.4-19	54HC11/YBDGAQ	6.4-17
54AC299/YBDGAQ	6.4-23	54F241	6.2-12	54HC132/YBDGAQ	6.4-17
54AC32/YBDGAQ	6.4-23	54F241/YBDGAQ	6.4-19	54HC138/YBDGAQ	6.4-17
54AC373/YBDGAQ	6.4-23	54F242	6.2-12	54HC139/YBDGAQ	6.4-17
54AC374/YBDGAQ	6.4-23	54F243	6.2-12	54HC14/YBDGAQ	6.4-17
54AC74/YBDGAQ	6.4-23	54F244	6.2-12	54HC151/YBDGAQ	6.4-17
54F00	6.2-12	54F244/YBDGAQ	6.4-19	54HC153/YBDGAQ	6.4-17
54F00/YBDGAQ	6.4-19	54F245	6.2-12	54HC157/YBDGAQ	6.4-17
54F02	6.2-12	54F245/YBDGAQ	6.4-19	54HC158/YBDGAQ	6.4-17
54F02/YBDGAQ	6.4-19	54F251	6.2-12	54HC160/YBDGAQ	6.4-17
54F04	6.2-12	54F253	6.2-12	54HC161/YBDGAQ	6.4-17
54F04/YBDGAQ	6.4-19	54F257	6.2-12	54HC162/YBDGAQ	6.4-17
54F08	6.2-12	54F258	6.2-12	54HC163/YBDGAQ	6.4-17
54F08/YBDGAQ	6.4-19	54F280	6.2-12	54HC164/YBDGAQ	6.4-17
54F10	6.2-12	54F283	6.2-12	54HC165/YBDGAQ	6.4-17
54F10/YBDGAQ	6.4-19	54F32	6.2-12	54HC173/YBDGAQ	6.4-17
54F109	6.2-12	54F32/YBDGAQ	6.4-19	54HC174/YBDGAQ	6.4-17
54F109/YBDGAQ	6.4-19	54F352	6.2-13	54HC175/YBDGAQ	6.4-17
54F11	6.2-12	54F353	6.2-15	54HC194/YBDGAQ	6.4-17
54F11/YBDGAQ	6.4-19	54F373	6.2-13	54HC195/YBDGAQ	6.4-17
54F125	6.2-12	54F373/YBDGAQ	6.4-19	54HC20/YBDGAQ	6.4-17
54F126	6.2-12	54F374	6.2-13	54HC240/YBDGAQ	6.4-17
54F13	6.2-12	54F374/YBDGAQ	6.4-19	54HC242/YBDGAQ	6.4-17
54F132	6.2-12	54F378	6.2-13	54HC244/YBDGAQ	6.4-17
54F138	6.2-12	54F379	6.2-13	54HC245/YBDGAP	6.4-17
54F138/YBDGAQ	6.4-19	54F381	6.2-13	54HC251/YBDGAQ	6.4-17
54F139	6.2-12	54F382	6.2-13	54HC253/YBDGAQ	6.4-18
54F139/YBDGAQ	6.4-19	54F398	6.2-13	54HC257/YBDGAQ	6.4-18
54F14	6.2-12	54F399	6.2-13	54HC280/YBDGAQ	6.4-18
54F151	6.2-12	54F521	6.2-13	54HC32/YBDGAQ	6.4-17
54F153	6.2-12	54F533	6.2-13	54HC373/YBDGAQ	6.4-18
54F153/YBDGAQ	6.4-19	54F534	6.2-13	54HC374/YBDGAQ	6.4-18
54F157A	6.2-12	54F64	6.2-13	54HC390/YBDGAQ	6.4-18
54F157A/YBDGAQ	6.4-19	54F64/YBDGAQ	6.4-19	54HC4002/YBDGAQ	6.4-18
54F158A	6.2-12	54F74	6.2-13	54HC4020/YBDGAQ	6.4-18
54F161A	6.2-12	54F74/YBDGAQ	6.4-19	54HC4024/YBDGAQ	6.4-18

# Device Index

54HC4040/YBDGAQ	6.4-18	54LS125A/RBDQ	6.4-21	54LS174	6.2-14
54HC4075/YBDGAQ	6.4-18	54LS125A/YBDGAQ2	6.4-21	54LS174/RBDQ	6.4-21
54HC42/YBDGAQ	6.4-17	54LS126A	6.2-14	54LS174/YBDGAQ2	6.4-21
54HC534/YBDGAQ	6.4-18	54LS13	6.2-14	54LS175	6.2-15
54HC74/YBDGAQ	6.4-17	54LS132	6.2-14	54LS175/RBDQ	6.4-21
54HC85/YBDGAQ	6.4-17	54LS132/RBDQ	6.4-21	54LS175/YBDGAQ2	6.4-21
54HC86/YBDGAQ	6.4-17	54LS132/YBDGAQ2	6.4-21	54LS181	6.2-15
54LS00	6.2-13	54LS133	6.2-14	54LS190	6.2-15
54LS00/RBDQ	6.4-20	54LS138	6.2-14	54LS191	6.2-15
54LS00/YBDGAQ2	6.4-20	54LS138/RBDQ	6.4-21	54LS191/RBDQ	6.4-22
54LS02	6.2-13	54LS138/YBDGAQ2	6.4-21	54LS191/YBDGAQ2	6.4-22
54LS02/RBDQ	6.4-20	54LS139	6.2-14	54LS192	6.2-15
54LS02/YBDGAQ2	6.4-20	54LS139/RBDQ	6.4-21	54LS193	6.2-15
54LS03	6.2-13	54LS139/YBDGAQ2	6.4-21	54LS193/RBDQ	6.4-22
54LS03/YBDGAQ2	6.4-20	54LS14	6.2-14	54LS193/YBDGAQ2	6.4-22
54LS04	6.2-13	54LS14/RBDQ	6.4-20	54LS194A	6.2-15
54LS04/RBDQ	6.4-20	54LS15	6.2-14	54LS195A	6.2-15
54LS04/YBDGAQ2	6.4-20	54LS151	6.2-14	54LS20	6.2-15
54LS05	6.2-13	54LS151/RBDQ	6.4-21	54LS20/RBDQ	6.4-20
54LS05/YBDGAQ2	6.4-20	54LS153	6.2-14	54LS20/YBDGAQ2	6.4-20
54LS08	6.2-13	54LS153/RBDQ	6.4-21	54LS21	6.2-15
54LS08/RBDQ	6.4-20	54LS153/YBDGAQ2	6.4-21	54LS21/RBDQ	6.4-20
54LS08/YBDGAQ2	6.4-20	54LS155	6.2-14	54LS21/YBDGAQ2	6.4-20
54LS09	6.2-13	54LS155/RBDQ	6.4-21	54LS22	6.2-15
54LS09/YBDGAQ2	6.4-20	54LS155/YBDGAQ2	6.4-21	54LS22/YBDGAQ2	6.4-20
54LS10	6.2-13	54LS156	6.2-14	54LS221	6.2-15
54LS10/RBDQ	6.4-20	54LS157	6.2-14	54LS221/YBDGAQ2	6.4-22
54LS10/YBDGAQ2	6.4-20	54LS157/RBDQ	6.4-21	54LS240	6.2-15
54LS107A	6.2-13	54LS157/YBDGAQ2	6.4-21	54LS240/RBDQ	6.4-22
54LS107A/YBDGAQ2	6.4-21	54LS158	6.2-14	54LS240/YBDGAQ2	6.4-22
54LS109A	6.2-13	54LS160A	6.2-14	54LS241	6.2-15
54LS109A/YBDGAQ2	6.4-21	54LS161A	6.2-14	54LS241/RBDQ	6.4-22
54LS11	6.2-13	54LS161A/RBDQ	6.4-21	54LS241/YBDGAQ2	6.4-22
54LS11/RBDQ	6.4-20	54LS161A/YBDGAQ2	6.4-21	54LS242	6.2-15
54LS11/YBDGAQ2	6.4-20	54LS162A	6.2-14	54LS243	6.2-15
54LS112A	6.2-13	54LS163A	6.2-14	54LS244	6.2-15
54LS112A/RBDQ	6.4-21	54LS163A/RBDQ	6.4-21	54LS244/RBDQ	6.4-22
54LS112A/YBDGAQ2	6.4-21	54LS163A/YBDGAQ2	6.4-21	54LS244/YBDGAQ2	6.4-22
54LS113A	6.2-14	54LS164	6.2-14	54LS245	6.2-15
54LS114A	6.2-14	54LS164/RBDQ	6.4-21	54LS245/RBDQ	6.4-22
54LS12	6.2-14	54LS164/YBDGAQ2	6.4-21	54LS245/YBDGAQ2	6.4-22
54LS122	6.2-14	54LS165	6.2-14	54LS251	6.2-15
54LS122/YBDGAQ2	6.4-21	54LS166	6.2-14	54LS253	6.2-15
54LS123	6.2-14	54LS169	6.2-14	54LS253/RBDQ	6.4-22
54LS123/RBDQ	6.4-21	54LS170/RBDQ	6.4-21	54LS253/YBDGAQ2	6.4-22
54LS123/YBDGAQ2	6.4-21	54LS170/YBDGAQ2	6.4-21	54LS257A	6.2-15
54LS125A	6.2-14	54LS173	6.2-14	54LS257A/RBDQ	6.4-22

# Device Index

54LS257A/YBDGAQ2	6.4-22	54LS374/YBDGAQ2	6.4-22	56001-20	6.2-27
54LS258A	6.2-15	54LS375	6.2-16	56001C20/YBRCC	6.4-10
54LS259	6.2-15	54LS377	6.2-16	56001C20/YBSCC	6.4-10
54LS259/RBDQ	6.4-22	54LS38	6.2-16	56002-40	6.2-27
54LS259/YBDGAQ2	6.4-22	54LS38/RBDQ	6.4-20	56156	6.2-4, 6.2-27
54LS26	6.2-15	54LS390	6.2-16	56824A-25	6.2-20
54LS26/RBDQ	6.4-20	54LS390/RBDQ	6.4-22	56824A-30	6.2-20
54LS26/YBDGAQ2	6.4-20	54LS390/YBDGAQ2	6.4-22	62S950A-15	6.2-21
54LS266	6.2-16	54LS393	6.2-16	62S950A-25	6.2-21
54LS27	6.2-16	54LS393/RBDQ	6.4-22	62S950A-35	6.2-21
54LS27/RBDQ	6.4-20	54LS393/YBDGAQ2	6.4-22	6205C-15	6.2-22
54LS273	6.2-16	54LS399	6.2-16	6205C-20	6.2-22
54LS273/RBDQ	6.4-22	54LS40	6.2-16	6205C-25	6.2-22
54LS273/YBDGAQ2	6.4-22	54LS42/RBDQ	6.4-20	6206C-100	6.2-22
54LS279	6.2-16	54LS42A	6.2-16	6206C-15	6.2-22
54LS279/RBDQ	6.4-22	54LS47	6.2-16	6206C-20	6.2-22
54LS279/YBDGAQ2	6.4-22	54LS51	6.2-17	6206C-25	6.2-22
54LS28	6.2-16	54LS51/RBDQ	6.4-20	6206C-35	6.2-22
54LS28/RBDQ	6.4-20	54LS51/YBDGAQ2	6.4-20	6206C-45	6.2-22
54LS28/YBDGAQ2	6.4-20	54LS54/YBDGAQ2	6.4-20	6206C-55	6.2-22
54LS280	6.2-16	54LS569	6.2-17	6206C-70	6.2-22
54LS283	6.2-16	54LS645	6.2-17	62110-15	6.2-20
54LS283/YBDGAQ2	6.4-22	54LS670	6.2-17	62110-25	6.2-20
54LS298	6.2-16	54LS670/RBDQ	6.4-22	62110-35	6.2-20
54LS298/YBDGAQ2	6.4-22	54LS670/YBDGAQ2	6.4-22	6226A-100	6.2-23
54LS30	6.2-16	54LS716	6.2-17	6226A-25	6.2-23
54LS30/YBDGAQ2	6.4-20	54LS718	6.2-17	6226A-30	6.2-23
54LS32	6.2-16	54LS719	6.2-17	6226A-35	6.2-23
54LS32/RBDQ	6.4-20	54LS73A	6.2-17	6226A-45	6.2-23
54LS32/YBDGAQ2	6.4-20	54LS73A/RBDQ	6.4-20	6226A-55	6.2-23
54LS365A	6.2-16	54LS73A/YBDGAQ2	6.4-20	6226A-70	6.2-23
54LS365A/YBDGAQ2	6.4-22	54LS74A	6.2-17	6229A-100	6.2-23
54LS366A	6.2-16	54LS74A/RBDQ	6.4-21	6229A-25	6.2-23
54LS366A/YBDGAQ2	6.4-22	54LS74A/YBDGAQ2	6.4-21	6229A-30	6.2-23
54LS367A	6.2-16	54LS75	6.2-17	6229A-35	6.2-23
54LS367A/RBDQ	6.4-22	54LS75/YBDGAQ2	6.4-21	6229A-45	6.2-23
54LS367A/YBDGAQ2	6.4-22	54LS76A	6.2-17	6229A-55	6.2-23
54LS368A	6.2-16	54LS85	6.2-17	6229A-70	6.2-23
54LS368A/YBDGAQ2	6.4-22	54LS85/RBDQ	6.4-21	62486A-15	6.2-20
54LS37	6.2-16	54LS85/YBDGAQ2	6.4-21	62486A-25	6.2-20
54LS37/RBDQ	6.4-20	54LS86	6.2-17	62486A-35	6.2-20
54LS37/YBDGAQ2	6.4-20	54LS86/RBDQ	6.4-21	6264C-15	6.2-23
54LS373	6.2-16	54LS86/YBDGAQ2	6.4-21	6264C-20	6.2-23
54LS373/RBDQ	6.4-22	54LS95B	6.2-17	6264C-25	6.2-23
54LS373/YBDGAQ2	6.4-22	55107	6.2-4	6264C-35	6.2-23
54LS374	6.2-16	56ADC16	6.2-27	6264C-45	6.2-23
54LS374/RBDQ	6.4-22	56ADC16	6.2-4	6264C-55	6.2-23

# Device Index

6264C-70	6.2-23
6268-35	6.2-23
6268-45	6.2-23
6268-55	6.2-24
6268-70	6.2-24
6287-35	6.2-24
6287-45	6.2-24
6288C-15	6.2-24
6288C-20	6.2-24
6288C-25	6.2-24
6288C-35	6.2-24
6288C-45	6.2-24
6294-30	6.2-20
6294-35	6.2-20
6294-40	6.2-20
62940A-15	6.2-20
62940A-25	6.2-20
62940A-35	6.2-20
62995A-15	6.2-20
62995A-25	6.2-20
62995A-35	6.2-21
651	5.1-16
6706A-15	6.2-21
6706A-20	6.2-21
6726A-15	6.2-21
6726A-20	6.2-21
6729A-15	6.2-21
6729A-20	6.2-21
68A09	6.2-24
68A21	6.2-24
68A488	6.2-24
68A50	6.2-24
68B09	6.2-24
68B21	6.2-24
68B488	6.2-24
68B50	6.2-24
68F333	6.2-27
68HC000-10	6.2-26
68HC000-12	6.2-26
68HC000-8	6.2-26
68HC000C10/YBDCC	6.4-8
68HC000C10/YBRCC	6.4-8
68HC000C12/YBDCC	6.4-8
68HC000C12/YBRCC	6.4-8
68HC000C8/YBDCC	6.4-8
68HC000C8/YBRCC	6.4-8
68HC001-8	6.2-26

68HC11A0	6.2-26
68HC11A1	6.2-26
68HC16Z1	6.2-26
68HC711K4	6.2-27
68HC811E2	6.2-27
6800	6.2-24
68000-10	6.2-25
68000-8	6.2-25
68000C10/YBDCC	6.4-8
68000C10/YBRCC	6.4-8
68000C8/YBDCC	6.4-8
68000C8/YBRCC	6.4-8
6802	6.2-24
68020-16	6.2-25
68020-20	6.2-25
68020-25	6.2-25
68020C16/YBRCC	6.4-8
68020C16/YBSCC	6.4-8
68020C20/YBRCC	6.4-8
68020C20/YBSCC	6.4-8
68020C25/YBRCC	6.4-8
68020C25/YBSCC	6.4-8
68030-16	6.2-25
68030-20	6.2-25
68030-25	6.2-25
68030-33	6.2-25
68040-25	6.2-25
68040C25/YBRCC	6.4-9
68040C25/YBSCC	6.4-9
6809	6.2-24
68150	6.2-26
68150	6.2-11
6821	6.2-24
68302-16	6.2-27
68302C16/YBRCC	6.4-9
68302C16/YBSCC	6.4-9
68332-16	6.2-27
68332C16/YBRCC	6.4-9
68332C16/YBSCC	6.4-9
68340	6.2-27
6840	6.2-24
6845	6.2-24
68488	6.2-24
6850	6.2-24
6852	6.2-25
6854	6.2-25
6875A	6.2-25

6875A	6.2-4
68882-16	6.2-26
68882-20	6.2-26
68882-25	6.2-26
68882-33	6.2-26
68882C16/YBRCC	6.4-9
68882C16/YBSCC	6.4-9
68882C20/YBRCC	6.4-9
68882C20/YBSCC	6.4-9
68882C25/YBRCC	6.4-9
68882C25/YBSCC	6.4-9
68902A	6.2-28
723/YBCMAQ	6.4-25
723/YBDGAQ	6.4-25
741/YBCMAQ	6.4-25
741/YBDGAQ	6.4-25
747/YBCMAQ	6.4-25
747/YBDGAQ	6.4-25
776/YBCMAQ	6.4-25
776/YBDGAQ	6.4-25
7805C/YBKMAQ	6.4-25
7812C/YBKMAQ	6.4-25
7815C/YBKMAQ	6.4-25
7824C/YBKMAQ	6.4-25
8T26AC/NBDGAP	6.4-25
8T97/NBDGAP	6.4-25
8T98/NBDGAP	6.4-25
88100-20	6.2-28
88100C20/YBRCC	6.4-10
88100C20/YBSCC	6.4-10
88200-20	6.2-28
88200C20/YBRCC	6.4-10
88200C20/YBSCC	6.4-10
88913	6.2-11
88914	6.2-11
88915-55	6.2-11
88915T-70	6.2-11
88916-80	6.2-11
88920-50	6.2-11
93L422	6.2-22
93L422A	6.2-22
93415	6.2-20
93422	6.2-20
93425	6.2-20
96002-33	6.2-27
96002C27/YBRCC	6.4-10
96002C27/YBSCC	6.4-10



# General Index

## A

A-D Converters	4.5-2
A-D/D-A Converters	4.5-3
A/D and D/A Converter Devices	4.11-6
Address and Control Bus Extenders	4.6-4
ADPCM Transcoder	4.7-25
Advanced NTSC Comb Filter	4.8-22
Advanced Packaging	1.1-1, 1.1-7
Advanced PAL/NTSC Comb Filter	4.8-23
Advanced PAL/NTSC Encoder	4.8-9
AGC Amplifiers	4.1-7
ALExIS	3.1-7, 3.1-22, 3.1-57
Alternator Voltage Regulator	4.9-8
Amplifier/Detector (Bipolar)	4.8-25
Amplifiers — Miscellaneous	4.1-8
Analog MPQ Table	4.11-8
Analog-to-Digital Converter (ADC)	2.5-30
Analog-to-Digital Conversion Modules	2.5-30
AND Gates	3.1-11
Application Development System	2.2-12
Application Specific Static RAMs	2.7-2
Arithmetic Operators	3.1-21
ASIC Preview	1.1-1
ASIC Regional Design Centers — United States	1.1-8
ASIC Regional Design Centers — International	1.1-8
Audio Cassette Courses, Technical Training	7.1-9
Audio/Servo Loads, Bipolar Power Transistors	5.5-18

## B

300 Baud FSK Modems	4.7-25
Balanced Modulator/Demodulator	4.7-3
BiCMOS Fast Static RAMs	2.7-3
Bipolar	1.1-1, 1.1-2
Bipolar A-D Converters	4.5-2
Bipolar Amplifiers	4.1-8
Bipolar D-A Converters	4.5-3
Bipolar Dual Operational Amplifiers	4.1-8
Bipolar Dual Voltage Comparators	4.1-8
Bipolar Linear Devices	4.11-2
Bipolar Power CRT Deflection	5.5-19
Bipolar Power Transistors	5.5-2
Bipolar Power Transistors, Audio	5.5-18
Bipolar Power Transistors, Audio/Servo Loads	5.5-18
Bipolar Power Transistors, CRT Deflection	5.5-19
Bipolar Power Transistors, DPAK	5.5-12
Bipolar Power Transistors, Metal	5.5-13
Bipolar Power Transistors, Plastic	5.5-3, 5.5-4, 5.5-7, 5.5-9, 5.5-10
Bipolar Power Transistors, TO-218	5.5-7
Bipolar Power Transistors, TO-220	5.5-3, 5.5-4
Bipolar Power Transistors, TO-225AA	5.5-10
Bipolar Power Transistors, TO-247	5.5-9
Bipolar Power Transistors, TO-264	5.5-10
Bipolar Telecommunications Circuit Summary	4.7-28
Block Erasable Flash EEPROM (BEFLASH)	2.5-30
Bounce Eliminator	3.1-9, 3.1-24

## B (continued)

Brushless DC Motor Controllers	4.3-4
Buffers	3.1-7
Bus Drivers (25 Ohm Outputs)	3.1-15
Bus-Oriented 3-State Circuits	3.1-13

## C

C-Compiler Packages	2.1-9
C-Quam AM Stereo Decoders	4.8-2
Cache/Memory Management Units	2.3-3
Calling Line ID Receiver Evaluation Kit	4.7-26
Calling Line Identification (CLID) Receiver with Ring Detector	4.7-26
CBM	3.1-9, 3.1-23
CDA Architecture (Customer Defined Arrays)	1.1-1, 1.1-4
Central Processing Unit	2.5-19
Central Processing Units	2.5-29
Checkers	3.1-21
Chroma 4 Family Block Diagram	4.8-6
Clock Drivers	3.1-7, 3.1-22
Closed-Caption Decoder	4.8-21
Closed-Loop Brushless Motor Adapter	4.3-8
CMOS	1.1-1, 1.1-3
CMOS A-D Converters	4.5-2
CMOS A-D/D-A Converters — For Telecommunications	4.5-3
CMOS D-A Converters	4.5-3
CMOS Display Drivers	4.6-8
CMOS Dual Programmable Comparators	4.1-8
CMOS Dual Programmable Operational Amplifiers	4.1-8
CMOS Dual Video Amplifiers	4.1-8
CMOS Fast Static RAMs	2.7-3
CMOS Overview	3.1-41
CMOS Quad Programmable Operational Amplifiers	4.1-8
CMOS Remote Control Functions	4.8-25
CMOS Transmitters	4.8-25
Comb Filters	4.8-4
Communication Modules	2.5-30
Communications Circuits Package Overview	4.7-32
Comparators	3.1-21, 4.1-9
Complex Gates	3.1-12
Composite Video Overlay Synchronizer	4.8-8
Configurable Timer Module (CTM)	2.5-29
Consumer Electronic Circuits Package Overview	4.8-26
Continuously Variable Slope Delta (CVSD) Modulator/Demodulator	4.7-27
Coprocessors	2.2-9
Counters	3.1-10, 3.1-17
CPU16	2.5-29
CPU32	2.5-29
Current Mode Switching Regulator	4.7-24

## D

D-A Converters	4.5-3
Data Communication Devices	2.2-10
Data Conversion Package Overview	4.5-4
Data Selectors	3.1-19

8

# General Index

## D (continued)

Data Set Interface Circuit (DSI)	4.7-15
DC Servo Motor Controller/Driver	4.3-7
Decoders	3.1-20, 4.8-3
Decoders/Demultiplexers	3.1-20
Deflection	4.8-3
Demultiplexers	3.1-20
Design Automation Software	1.1-1, 1.1-6
Design-In Software Packages	2.1-8
Design-NET - Motorola Data On-Line	7.1-1
Detectors	3.1-10
Developer's Workbench	2.6-5
Development Tools	2.2-12
Device Nomenclature - Logic	3.1-55
Digital Chroma Delay Line	4.8-13
Digital I/O and Special Functions	2.5-19
Digital Signal Processors	2.1-1
Digital-to-Analog Conversion	2.5-19
Digitally Controlled Video Processor for Multimedia Applications	4.8-11
Direct Memory Access (DMA)	2.5-30
Discrete Products	5.0-1
Discrete Surface Mount Information	5.11-2
Display Decode Dividers	3.1-20
Display Driver Devices	4.11-6
DMA Controllers	2.2-9
Double-Ended Controllers	4.2-10
DRAM Memory Cards	2.7-7
DRAM Modules	2.7-5
DSP Development Tools	2.1-7
DTL Circuits	3.1-54, 3.1-57
Dual Bipolar Comparators	4.1-9
Dual Channel Current Mode Controllers	4.2-11
Dual CMOS Comparators	4.1-9
Dual Comparators	4.1-9
Dual Data Link Controller	4.7-13
Dual Operational Amplifier and Dual Voltage Comparator	4.1-8
Dual Operational Amplifiers	4.1-3
Dual Timing Circuits	4.10-2
Dual Tone Multiple Frequency Receiver	4.7-11
Dual Universal Asynchronous/ Synchronous Receiver Transmitter (DUART)	2.5-30
Dual Video Amplifiers	4.8-24
Dynamic RAMs	2.7-5
Dynamic RAMs (HCMOS)	2.7-6

## E

ECL Series Arrays	1.1-1, 1.1-2
ECLinPS	3.1-39, 3.1-56
ECLinPS Lite	3.1-40, 3.1-56
EIA Standard Line Drivers	4.6-6
EIA Standard Line Receivers	4.6-5
EIA-232-D/V.28 CMOS Drivers/Receivers	4.6-7
Electronic Ignition	4.9-2
Electronic Telephone	4.7-16
Electronic Telephone Circuits	4.7-16

## E (continued)

Embedded Controllers	2.2-5
Emitters and Detectors, Optoelectronic Devices	5.8-1, 5.8-14, 5.8-16
Encoders	4.8-3
Enhanced Ethernet Serial Transceiver (EEST)	4.6-2
Entertainment Radio Receiver Circuits	4.8-2
Entertainment Radio Receiver Circuits - Audio Amplifiers	4.8-2
Entertainment Radio Receiver Circuits - Audio Attenuator	4.8-2
Entertainment Receiver RF/IF	4.8-2
ETL Series Arrays	1.1-1, 1.1-2
Exclusive NOR Gates	3.1-12
Exclusive OR Gates	3.1-12

## F

FACT	3.1-42, 3.1-49, 3.1-56
FACT - TTL Compatible	3.1-51
Family Wideband General Purpose Amplifiers	4.1-7
FAST	3.1-31, 3.1-55
Fast Static RAM Modules	2.7-4
Fast Static RAMs	2.7-2
FETs, TMOS Power MOSFETs	5.4-1
Fiber Distributed Data Interface	2.2-11
Fiber Optics, Optoelectronic Devices	5.8-1, 5.8-16
Field-Effect Transistors, Small Signal	5.1-20
Flash EEPROM (FLASH)	2.5-30
Flash Modules	2.7-6
Flip-Flop/Registers	3.1-16
Flip-Flops	3.1-7, 3.1-16
Footprints for Soldering, Discrete	5.11-5
Fuzzy Logic	2.5-43

## G

1.3 GHz Tuner PLL with 3-Wire Control	4.8-19
1.3 GHz Tuner PLL with I <sup>2</sup> C Control	4.8-18
Gated 2-Channel Input Amplifiers	4.1-7
General Memory Products	2.7-6
General Purpose I/O	2.2-11
General Purpose Line Drivers	4.6-6
General Purpose Line Receivers	4.6-5
General Purpose Timer (GPT)	2.5-29
GPIO/IEEE Standard 488, Instrumentation Bus	4.6-5

## H

H4C Series	1.1-1, 1.1-4
H4CPlus Series	1.1-1, 1.1-5
HDC Series	1.1-1, 1.1-3
HDTMOS Power MOSFETs	5.4-3
Hex 3-State Buffers/Inverters	4.6-4
High Cell Density (HDTMOS)	5.4-3
High Frequency Amplifiers	4.1-7
High Performance Decoder Driver/Sink Driver	4.6-3
High Side TMOS Driver	4.9-7
High-Side Driver Switch	4.3-3
High-Speed CMOS	3.1-41, 3.1-46, 3.1-56
High-Speed CMOS - TTL Compatible	3.1-49

# General Index

## H (continued)

High-Current Party-Line Bus for Industrial and Data Communications	4.6-5
Hot-Carrier (Schottky) Diodes, Small Signal	5.1-33
How to Access Freeware	2.5-43
HTL Circuits	3.1-54, 3.1-57
Hybrid Power Modules	5.3-1

## I

360/370 I/O Interface Line Drivers	4.6-6
ICePAK Leadform Options	5.13-10
ICePAK Multiple Chip Packages	5.4-21
IEEE 802.3 Transceivers	4.6-8
IF Circuits	4.8-4
IGBTs (Insulated Gate Bipolar Transistor), Power MOSFETs	5.4-23
IGBTs, Hybrid Power Modules	5.3-2
Industrial Control Unit	3.1-9, 3.1-24
Insulated Gate Bipolar Transistor, Power MOSFETs	5.4-23
Insulated Gate Bipolar Transistors, Hybrid Power Modules	5.3-2
Integrated Circuits, RF	5.10-20
Integrated Power Stage IGBTs, Hybrid Power Modules	5.3-2
Integrated Processors	2.2-7
Integrated Services Digital Network	4.7-11
Integration Modules	2.5-29
Interface Package Overview	4.6-10
Intermodule Bus Peripherals	2.5-29
Inverters/Buffers (2-State)	3.1-13
ISDN Voice/Data Circuits	4.7-11
ISO 8802-3[IEEE 802.3] 10BASE-T Transceiver	4.6-3

## L

Latches	3.1-7, 3.1-15
Leadform Options, Discrete	5.13-1
Line Drivers	4.6-6
Line Receivers	4.6-5
Line Transceivers	4.6-7
Linear and Interface Devices	4.11-2
Linear Circuits Package Overview	4.10-4
Linear Four-Quadrant Multipliers	4.10-2
Linear Voltage Regulators	4.2-2
Linear Voltage Regulators — Adjustable Output	4.2-5
Linear Voltage Regulators — Fixed Output	4.2-2
Logic Literature Listing	3.1-64
LonWorks Products	2.6-1
Low Side Protected Switch	4.9-6
LS — Low Power Schottky	3.1-27, 3.1-55

## M

M6800 Series Microprocessors and Peripherals	2.5-27
M68000 Family	2.2-1
M68040FPSP	2.2-12
M68300 Family	2.5-36
M68340EVS — Evaluation System	2.2-12

## M (continued)

M68EC0x01DP — Evaluation Boards for Embedded Controllers	2.2-12
M68HC05 Analog I/O + EEPROM Microcontrollers	2.5-2
M68HC05 CSIC Family	2.5-2
M68HC05 Display Microcontrollers	2.5-2
M68HC05 Family	2.5-39
M68HC05 General Purpose Microcontrollers	2.5-2
M68HC05 Smart Card Microcontrollers	2.5-3
M68HC05 Telephone Microcontrollers	2.5-2
M68HC08 Family	2.5-18
M68HC11 Family	2.5-19, 2.5-39
M68HC16 Family	2.5-31
M68KESW-PC1	2.2-12
M88000 RISC Family	2.3-1
Masked ROM (MRM)	2.5-30
Math Coprocessor	2.5-19
MC2681 — Dual Universal Asynchronous Receiver/Transmitter, DUART	2.2-10
MC68000 — The 16-Bit Foundations	2.2-4
MC68008 — An 8-Bit Compatible Competitor	2.2-4
MC68010 — A Virtual Memory Enhancement	2.2-4
MC68020 — The Original 32-Bit Performance Standard	2.2-4
MC68030 — The Second Generation 32-Bit MPU	2.2-3
MC68040 — Third-Generation 32-Bit Microprocessor	2.2-3
MC68060 — Superscaler 32-Bit Microprocessor	2.2-3
MC68184 — Broadband Interface Controller	2.2-9
MC68185 — Twisted-Pair Modem	2.2-9
MC68194 — Carrierband Modem	2.2-10
MC68195 — LocalTalk Adaptor	2.2-10
MC68230 — Parallel Interface/Timer, PI/T	2.2-11
MC68302 — Integrated Multiprotocol Processor	2.2-7
MC68306 — Integrated 68EC00 Processor	2.2-8
MC68330 — Integrated CPU32 Processor	2.2-8
MC68331 — 32-Bit Microcontroller	2.2-8
MC68332 — 32-Bit Microcontroller	2.2-8
MC68334 — 32-Bit Microcontroller	2.2-8
MC68340 — Integrated Multiprotocol Processor with DMA	2.2-8
MC68440 — Dual Direct Memory Access Controller, DDMA	2.2-9
MC68450 — DMA Controller, DMAC	2.2-9
MC68605 — X.25 Protocol Controller, XPC	2.2-10
MC68606 — Multi-Link LAPD Controller CCITT Q.920/Q.921, LAPD	2.2-10
MC68681 — Dual Universal Asynchronous Receiver/Transmitter, DUART	2.2-10
MC68824 — Token Bus Controller, TBC	2.2-9
MC68836 — FDDI Clock Generator	2.2-11
MC68837 — Elasticity Buffer and Link Manager	2.2-11
MC68838 — Media Access Controller	2.2-11
MC68839 — FDDI System Interface	2.2-11
MC68851 — Paged Memory Management Unit, PMMU	2.2-9
MC68881 — A Floating Point Coprocessor	2.2-9
MC68882 — Enhanced Floating Point Coprocessor	2.2-9
MC68901 — Multifunction Peripheral, MFP	2.2-11
MC68EC000 — Low-Powered HCMOS Embedded Controller	2.2-6



# General Index

## M (continued)

MC68EC020 — 32-Bit Embedded Controller	2.2-6
MC68EC030 — 32-Bit Enhanced Embedded Controller	2.2-6
MC68EC040 — 32-Bit High-Performance Embedded Controller	2.2-5
MC68F333 — 32-Bit Microcontroller	2.2-8
MC68HC000 — A Micropower Alternative	2.2-4
MC68HC001 — Low Power HCMOS 8-/16-/32-Bit Microprocessor	2.2-4
MC68HC05 Microcontrollers	2.5-7
MC88100RC — 32-Bit RISC Microprocessor	2.3-2
MC88110RC — 32-Bit RISC Microprocessor	2.3-2
MC88200RC — 16-Kilobyte Cache/Memory Management Unit	2.3-3
MC88204RC — 64K-Byte Cache/Memory Management Unit	2.3-3
MC88410 — Secondary Cache Controller	2.3-3
MCA Arrays	1.1-2
MECL 10H	3.1-37, 3.1-55
MECL 10K	3.1-35, 3.1-55
MECL III	3.1-54, 3.1-57
MECL Overview	3.1-34
Medium Power MOSFETs, TMOS	5.4-5, 5.4-14
Memory Modules	2.5-30
Memory Support	3.1-9, 3.1-23
Metal Gate 14000 Series CMOS	3.1-41, 3.1-43, 3.1-56
Mfax — Touch-Tone FAX for Technical Data	7.1-1
MI-Bus Interface Stepper Motor Controller	4.9-8
Microcomputer Components, Single-Chip Microcontrollers (MCU)	2.5-1
Microcontroller Development Tools	2.5-39
Microcontroller Electronic Bulletin Board	2.5-43
MicroCool QFP (Quad Flat Package)	1.1-1, 1.1-7
Microprocessor Bus Interface	4.6-4
Microprocessor Data Bus Extenders	4.6-4
Microprocessor Magnetic Read/Write	4.6-4
Microprocessor Voltage Regulator and Supervisory Circuit	4.2-16
Microprocessor Voltage Regulator/Supervisory Circuit	4.2-6
Microprocessors	2.2-2, 2.3-2
MiniMOS Products	5.4-3, 5.4-4, 5.4-14
Mixers	3.1-10
Modular Microcontroller Families	2.5-39
Modular Microcontrollers	2.5-29
Modulators	4.8-4
Monitor Subsystem	4.8-4
MOS Digital-Analog Devices	4.11-6
MOS Memories	2.7-1
MOSAIC III	1.1-1, 1.1-2
MOSFET Drivers	4.2-17
MOSFETs, Power, TMOS	5.4-1
Motor Controllers	4.3-4
Motorola Device Classification, Discrete	5.0-2
MPC601 RISC Microprocessor	2.4-2
MPC603 RISC Microprocessor	2.4-4
Multi-Channel Communications Interface (MCCI)	2.5-30
Multiple Chip Power Module Devices, (ICePAK)	5.4-21

## M (continued)

Multiplexers	3.1-19
Multiplexers/Data Selectors	3.1-19
Multipliers	4.10-2
Multistandard Video IF	4.8-17
Multistandard Video/Timebase Processor	4.8-10
Multivibrators	3.1-10, 3.1-20

## N

NAND Gates	3.1-11
Narrowband Dual Conversion Receivers — FM/FSK — VHF	4.7-2
Narrowband FM Receiver	4.7-6
Narrowband Single Conversion Receivers — VHF	4.7-2
Network Devices	2.2-9
Neuron Chips	2.6-2
NOR Gates	3.1-11

## O

OACS (Open Architecture CAD System)	1.1-1, 1.1-6
Octal Serial Switch	4.9-5
OMPAC (Over-Molded Pad Array Carrier)	1.1-1, 1.1-7
On-Chip Memory	2.5-19
On-Line Help	2.5-43
One-Time Programmable (OTP) / Emulator MCUs	2.5-13
Operational Amplifier/Comparator Devices	4.11-6
Operational Amplifiers	4.1-2
Optoelectronic Devices	5.8-1
Optoelectronic Devices, 6-Pin Devices	5.8-1, 5.8-5, 5.8-9
Optoelectronic Devices, Emitters and Detectors	5.8-1, 5.8-14, 5.8-16
Optoelectronic Devices, Fiber Optics	5.8-1, 5.8-16
Optoelectronic Devices, Optointerrupters	5.8-1, 5.8-15
Optoelectronic Devices, Optoisolators	5.8-1, 5.8-2
Optoelectronic Devices, POWER OPTO Isolators	5.8-1, 5.8-13
Optointerrupters, Optoelectronic Devices	5.8-1, 5.8-15
Optoisolators, Optoelectronic Devices	5.8-1, 5.8-2
Optoisolators, SO-8	5.8-12
OR Gates	3.1-11
Ordering Information, Logic	3.1-55
Oscillators	3.1-10, 3.1-21
Oscillators/Timers	3.1-21
Over/Undervoltage Protection Circuit	4.2-14
Overvoltage Crowbar Sensing Circuit	4.2-14

## P

Packaging Specifications, Discrete	5.12-7
Parity Generators	3.1-21
Parity Generators/Checkers	3.1-21
PBX Architecture (Analog Transmission)	4.7-8
PBX Architecture Crosspoint Switches	4.7-11
PCM Mono-Circuits Codec-Filters (CMOS LSI)	4.7-8
PCMCIA Flash Cards	2.7-7
Peripheral Drivers	4.6-7
Peripherals	2.1-5
Phase-Locked-Loop Components	4.7-30

# General Index

## P (continued)

Phase-Locked-Loop Control Functions	4.7-31
Phase-Locked-Loop Intended Applications	4.7-30
Phase-Locked-Loop Oscillators	4.7-31
Phase-Locked-Loop Phase Detectors	4.7-31
Phase-Locked-Loop Prescalers/Counters	4.7-31
Phase-Locked Loop	3.1-9, 3.1-24
Phase-Locked-Loop Frequency Synthesizer Devices	4.11-6
Pixel Clock Generator and Sync Separator	4.8-15
PLCC	4.11-8
PLL Frequency Synthesizers	4.7-30
PLL Tuning Circuit with DACs for Tuner Alignment	4.8-20
Power Audio Output Stage	5.5-18
Power Bipolar Transistors, RF	5.10-6
Power Controllers	4.3-2
Power Factor Controllers	4.2-12
Power MOSFETs, D <sup>2</sup> PAK	5.4-7, 5.4-15
Power MOSFETs, DPAK	5.4-6, 5.4-15
Power MOSFETs, High Power Products	5.4-12
Power MOSFETs, Ignition IGBTs	5.4-23
Power MOSFETs, Logic Level Packages	5.4-18, 5.4-19, 5.4-20
Power MOSFETs, RF	5.10-4
Power MOSFETs, SO-8	5.4-3, 5.4-4, 5.4-14
Power MOSFETs, SOT-223	5.4-5, 5.4-14
Power MOSFETs, SOT-227B	5.4-22
Power MOSFETs, TMOS	5.4-1
Power MOSFETs, TO-204AA (TO-3), Metal Packages	5.4-13, 5.4-17
Power MOSFETs, TO-220 Isolated	5.4-10, 5.4-16
Power MOSFETs, TO-220AB	5.4-8, 5.4-16
Power MOSFETs, TO-247 Isolated Mounting Hole	5.4-11, 5.4-17
Power MOSFETs, TO-264 High Power Products	5.4-12
Power MOSFETs, TO-3PBL	5.4-12
POWER OPTO Isolators, Optoelectronic Devices	5.8-1, 5.8-13
Power Supervisory Circuits	4.2-14
PowerPC RISC Family	2.4-1
Precision Low Voltage References	4.4-2
Preferred Devices, Motorola, Discrete	5.0-2
Prescalers	3.1-9
Pressure Sensors	5.9-2
Pressure Sensors, 4-Pin	5.9-6, 5.9-7, 5.9-8, 5.9-9, 5.9-10
Pressure Sensors, 6-Pin	5.9-6, 5.9-7, 5.9-10
Pressure Sensors, Compensated and Calibrated	5.9-4, 5.9-9
Pressure Sensors, High Impedance	5.9-4, 5.9-10
Pressure Sensors, Motorola's Patented X-ducer	5.9-2
Pressure Sensors, Packaging Options	5.9-6
Pressure Sensors, Signal Conditioned	5.9-4, 5.9-10
Pressure Sensors, Uncompensated	5.9-4, 5.9-8
Priority Encoders	3.1-20
Programmable Delay Chips	3.1-8, 3.1-23
Pulse-Width Modulation	2.5-19

## Q

QFP-MCR (Quad Flat Package-Molded Carrier Ring)	1.1-1
QFP-MCR (Quad Flat Package-Molded Carrier Ring)	1.1-7

## Q (continued)

Quad Bipolar Comparators	4.1-10
Quad CMOS Comparators	4.1-10
Quad Comparators	4.1-10
Quad Fuel Injector Driver	4.9-4
Quad Operational Amplifiers	4.1-5
Quad Programmable Operational Amplifier	4.1-8
Queued Analog-to-Digital Converter (QADC)	2.5-30
Queued Serial Module (QSM)	2.5-30

## R

Receivers	3.1-21
Rectifier Numbering System	5.6-2
Rectifiers	5.6-1
Rectifiers, Application Specific	5.6-3
Rectifiers, Automotive Transient Suppressors	5.6-3
Rectifiers, Axial Lead Schottky	5.6-6
Rectifiers, Axial Lead Ultrafast	5.6-11
Rectifiers, Fast Recovery	5.6-14
Rectifiers, General Purpose	5.6-14
Rectifiers, Low V <sub>F</sub> Schottky	5.6-3
Rectifiers, MEGAHERTZ	5.6-3
Rectifiers, POWER TAP II Schottky	5.6-10
Rectifiers, POWER TAP II Ultrafast	5.6-13
Rectifiers, SCANSWITCH	5.6-3
Rectifiers, SOT-227B Schottky	5.6-10
Rectifiers, SOT-227B Ultrafast	5.6-13
Rectifiers, Surface Mount Schottky	5.6-4
Rectifiers, SWITCHMODE	5.6-4
Rectifiers, TO-204AA, DO-203AA and DO-203AB Schottky Metal Packages	5.6-9
Rectifiers, TO-218 Types and TO-247 Schottky	5.6-8
Rectifiers, TO-218 Types Ultrafast	5.6-13
Rectifiers, TO-220 Type Schottky	5.6-7
Rectifiers, TO-220 Type Ultrafast	5.6-12
Rectifiers, TO-247 Ultrafast	5.6-13
Rectifiers, Ultrafast	5.6-11
Register Files	3.1-18
Registers	3.1-7, 3.1-16
Remote Control Application 40 kHz Carrier	4.8-25
Remote Control Circuits	4.8-25
Remote Control Function Devices	4.11-7
RF Amplifiers	5.10-23
RF Communications	4.7-2
RF Discrete Transistors	5.10-2
RF HF Transistors	5.10-6
RF Integrated Circuits	5.10-20
RF Linear Transistors	5.10-12
RF Microwave Transistors	5.10-10
RF Power Bipolar Transistors	5.10-6
RF Power MOSFETs	5.10-4
RF Products	5.10-1
RF Small Signal Bipolar Transistors	5.10-14
RF UHF Transistors	5.10-7
RF VHF Transistors	5.10-6

# General Index

## R (continued)

RF, SC-70/SOT-323	5.10-17
RF, SO-8	5.10-17, 5.10-20
RF, SOT-143	5.10-17
RF, SOT-23	5.10-16

## S

S/T-Interface Transceivers	4.7-12
Schmitt Triggers	3.1-15
SCSI Bus Terminators	3.1-9, 3.1-23
SCSI Regulator	4.2-6
Semicustom Application Specific Integrated Circuits	1.0-1
Serial Communication	2.5-19
Shift Registers	3.1-18
Single Bipolar Comparators	4.1-9
Single CMOS Comparators	4.1-9
Single Comparators	4.1-9
Single Operational Amplifiers	4.1-2
Single Timing Circuits	4.10-2
Single-Chip Integration Module (SCIM)	2.5-29
Single-Ended Bus Transceivers	4.6-5
Single-Ended Controllers	4.2-7
Small Signal Bipolar Transistors	5.1-2
Small Signal Bipolar Transistors, RF	5.10-14
Small Signal Transistors	5.1-1
Small Signal Tuning and Switching Diodes	5.1-25, 5.1-34
Small Signal, DO-204AA (DO-7)	5.1-26, 5.1-32
Small Signal, FETs	5.1-23
Small Signal, Hot-Carrier (Schottky) Diodes	5.1-33
Small Signal, JFETs	5.1-20
Small Signal, SC-59	5.1-11, 5.1-35
Small Signal, SC-70/SOT-323	5.1-11, 5.1-35
Small Signal, SO-14	5.1-38
Small Signal, SO-16	5.1-9, 5.1-38
Small Signal, SOT-223	5.1-15, 5.1-24, 5.1-32
Small Signal, SOT-23	5.1-10, 5.1-23, 5.1-28, 5.1-31, 5.1-35
Small Signal, TMOS MOSFETs	5.1-22
Small Signal, TO-116	5.1-9, 5.1-38
Small Signal, TO-205AD (TO-39)	5.1-17
Small Signal, TO-206AA (TO-18)	5.1-17
Small Signal, TO-226AA (TO-92)	5.1-2, 5.1-20, 5.1-22, 5.1-28
Small Signal, TO-226AC (TO-92)	5.1-27, 5.1-31, 5.1-32, 5.1-33, 5.1-35
Small Signal, TO-226AE (TO-92)	5.1-3, 5.1-22
Small Signal, TO-236AB	5.1-10, 5.1-23, 5.1-31, 5.1-32, 5.1-33, 5.1-35
SMARTDISCRETES Products	5.4-23
Smoke Detector Devices	4.11-7
Smoke Detectors (CMOS)	4.10-3
Software Support	2.2-12
SOIC	4.11-8
Sound	4.8-5
Speakerphone	4.7-20
Speakerphone Integrated Circuits	4.7-23
Special Functions	4.9-3

## S (continued)

Special Logic Circuits	3.1-7, 3.1-22, 3.1-57
Special Regulators	4.2-6
Special Switching Regulator Controllers	4.2-11
Specialized Control Modules	2.5-30
Speech Network with Dialer Interface	4.7-18
Speech Networks	4.7-18
Standby RAM (SRAM)	2.5-30
Standby RAM with TPU Emulation (TPURAM)	2.5-30
Starter Kit	2.6-5
Stepper Motor Driver	4.3-9
Sub-Micron CMOS	1.1-1, 1.1-5
Subcarrier Reference	4.8-14
Subscriber Loop Interface Circuits (SLIC)	4.7-7
Surface Mount Information, Discrete	5.11-2
Surface Mount Products, Bipolar Power Transistors	5.5-12
Surface Mount Products, Optoelectronic Devices	5.8-9, 5.8-12
Surface Mount Products, Power MOSFETs	5.4-3, 5.4-4, 5.4-5, 5.4-6, 5.4-7, 5.4-14, 5.4-15
Surface Mount Products, Rectifiers	5.6-4
Surface Mount Products, RF	5.10-16, 5.10-17, 5.10-20
Surface Mount Products, Small Signal	5.1-9, 5.1-10, 5.1-23, 5.1-28, 5.1-32, 5.1-35, 5.1-36
Surface Mount Products, Thyristors	5.7-3, 5.7-7
Surface Mount Products, TVS/Zeners	5.2-9, 5.2-21
Surface Mount Technology Package Overview	4.11-8
Switching Regulator Control Circuits	4.2-7
SWITCHMODE Rectifiers	5.6-4
System Integration Module (SIM)	2.5-29

## T

Tape and Reel - Logic	3.1-63
Tape and Reel Specifications, Discrete	5.12-2
Tape and Reel, Logic and Analog Technologies and MOS Integrated Circuits	4.11-9
Tape/Reel and Ammo Pack	4.11-8
Technical Data and Literature	7.1-2, 7.1-5
Technical Data Services	7.1-1
Technical Training	7.1-6
Technical Training Centers	7.1-8
Telecommunications	4.7-7
Telecommunications Devices	4.11-7
Telephone Accessory Circuits	4.7-24
Telephone Accessory Circuits - Audio Amplifiers	4.7-24
Telephone Accessory Circuits - Bit Rate Generators	4.7-25
Telephone Speech Network with Dialer Interface	4.7-19
Television Subsystems	4.8-4
Temperature Sensors	5.9-4, 5.9-12
Terminators, SCSI Bus	3.1-9, 3.1-23
Third-Party Development Tools	2.5-44
Third-Party Support	2.5-44
Thyristors, DPAK	5.7-3
Thyristors, Optically Isolated TRIACs	5.7-16
Thyristors, Programmable Unijunction Transistors	5.7-17
Thyristors, SIDACs	5.7-17

# General Index

## T (continued)

Thyristors, Silicon Bidirectional Switch	5.7-17
Thyristors, Silicon Controlled Rectifiers	5.7-2
Thyristors, SOT-223	5.7-7
Thyristors, TRIAC Driver/TRIAC Combinations	5.7-16
Thyristors, TRIACs, General Purpose	5.7-7
Thyristors, Triggers	5.7-17
Time Processor Unit (TPU)	2.5-29
Timer	2.5-19
Timer Module (TM)	2.5-30
Timers	2.5-29, 3.1-21
Timing Circuits	4.10-2
Timing Solutions	3.1-7, 3.1-22
TMOS MOSFETs, Small Signal	5.1-22
TMOS Power MOSFETs	5.4-1
TMOS Power MOSFETs Numbering System	5.4-2
TMOS V	5.4-24
TO-92	4.11-8
TO-220, Leadform Options, Discrete	5.13-5
TO-225AA, Leadform Options, Discrete	5.13-2
TO-92, Leadform Options, Discrete	5.13-2
Tone Ringers	4.7-17
Transceivers	3.1-7, 3.1-15
Transient Voltage Suppressors	5.2-2
Transient Voltage Suppressors, Axial Leaded for Through-hole Designs	5.2-2
Transient Voltage Suppressors, General Purpose	5.2-2
Transient Voltage Suppressors, Mini Mosorb	5.2-2
Transient Voltage Suppressors, Mosorb	5.2-6
Transient Voltage Suppressors, Overvoltage Transient	5.2-15
Transient Voltage Suppressors, SMC	5.2-13
Transient Voltage Suppressors, Surface Mount	5.2-9
Transient Voltage Suppressors, Surmetic 40	5.2-4, 5.2-18
Translators	3.1-8, 3.1-13, 3.1-23
Transmitters — AM/FM/FSK	4.7-3
Triac Phase Angle Controller	4.3-11
Triple 8-Bit A/D Converter	4.8-16
Triple 8-Bit D/A Converter	4.8-15
Triple-Layer Metal	1.1-1, 1.1-3
TTL Overview	3.1-26
Tuner PLL Circuits	4.8-4
TV Stereo Decoder for NICAM and German System	4.8-12
TVS/Zeners	5.2-1
TVS/Zeners, DO-204AA (DO-7)	5.2-31
TVS/Zeners, DO-204AH (DO-35)	5.2-16, 5.2-31
TVS/Zeners, SMB	5.2-10, 5.2-21

## T (continued)

TVS/Zeners, SOD-123	5.2-21, 5.2-26
TVS/Zeners, SOT-23	5.2-9, 5.2-21, 5.2-24

## U

U-Interface Transceivers	4.7-12
UHF, FM/AM Transmitter	4.7-6
Ultrafast Rectifiers	5.6-11
Undervoltage Sensing Circuit	4.2-15
Universal Microprocessor Power Supply Controller	4.2-11
Universal Motor Speed Controllers	4.3-10
Universal Voltage Monitor	4.2-16

## V

Video Capture Chip Sets	4.8-3
Video Circuits	4.8-3
Video Circuits — Miscellaneous	4.8-5
Video Data Converters	4.8-4
Video Input Processing	4.8-7
Video Output Processing	4.8-7
Video Training, Technical Training	7.1-10
Voice Switched Speakerphone Circuit	4.7-20, 4.7-22
Voice Switched Speakerphone with $\mu$ Processor Interface	4.7-21
Voice/Data Communication (Digital Transmission)	4.7-14
Voltage Regulators	4.9-2

## W

2-Wire ISDN Universal Digital Loop Transceiver II (UDLT II)	4.7-15
2-Wire Universal Digital Loop Transceiver (UDLT)	4.7-14
Wideband (FM/FSK) IFs	4.7-2
Wideband FM IF	4.7-4
Wideband FM IF System	4.7-5
Wideband Single Conversion Receivers — VHF	4.7-2

## X

XNOR Gates	3.1-12
XOR Gates	3.1-12

## Z

Zener Diodes, Axial Leaded for Through-hole Designs	5.2-16
Zener Diodes, Current Regulator	5.2-31
Zener Diodes, Surmetic 30	5.2-18
Zener Diodes, Voltage Reference	5.2-31
Zener Diodes, Voltage Regulator	5.2-16
Zero Voltage Controller	4.3-3
Zero Voltage Switches	4.3-2

# Subject Index

## A

<b>ALExis – Advanced Low-Power Expandable Interface Solutions</b> .....	3.1–7
<b>Amplifiers and Comparators</b> .....	4.1–1
Comparators .....	4.1–9
Dual .....	4.1–9
Bipolar .....	4.1–9
CMOS .....	4.1–9
Quad .....	4.1–10
Bipolar .....	4.1–10
CMOS .....	4.1–10
Single .....	4.1–9
Bipolar .....	4.1–9
CMOS .....	4.1–9
High Frequency Amplifiers .....	4.1–7
AGC Amplifiers .....	4.1–7
Family Wideband General Purpose .....	4.1–7
Gated 2-Channel Input .....	4.1–7
Miscellaneous Amplifiers .....	4.1–8
Bipolar .....	4.1–8
Dual Operational Amplifier and Dual Voltage Comparator .....	4.1–8
CMOS .....	4.1–8
Dual Programmable Operational Amplifier and Dual Programmable Comparator .....	4.1–8
Dual Video Amplifiers .....	4.1–8
Quad Programmable Operational Amplifier .....	4.1–8
Operational Amplifiers .....	4.1–2
Dual Operational Amplifiers .....	4.1–3
Quad Operational Amplifiers .....	4.1–5
Single Operational Amplifiers .....	4.1–2
<b>Automotive Electronic Circuits</b> .....	4.9–1
Alternator Voltage Regulator .....	4.9–8
Electronic Ignition .....	4.9–2
High Side T MOS Driver .....	4.9–7
Low Side Protected Switch .....	4.9–6
MI-Bus Interface Stepper Motor Controller .....	4.9–8
Octal Serial Switch .....	4.9–5
Quad Fuel Injector Driver .....	4.9–4
Special Functions .....	4.9–3
Voltage Regulators .....	4.9–2

## B

<b>Bipolar Power Transistors</b> .....	5.5–2
Audio .....	5.5–18
Audio/Servo Loads .....	5.5–18
CRT Deflection .....	5.5–19
DPAK–Surface Mount .....	5.5–12
Metal .....	5.5–13
Plastic .....	5.5–3
TO–218 .....	5.5–7
TO–220, Isolated .....	5.5–3
TO–220AB .....	5.5–4
TO–225AA .....	5.5–10
TO–247 .....	5.5–9
TO–264 .....	5.5–10
<b>Bounce Eliminator</b> .....	3.1–9

## C

<b>CBM</b> .....	3.1–9
<b>CMOS</b> .....	3.1–41
FACT .....	3.1–42, 3.1–49
FACT – TTL Compatible .....	3.1–51

## C (continued)

<b>CMOS (continued)</b> .....	3.1–41, 3.1–46
High-Speed .....	3.1–49
High-Speed – TTL Compatible .....	3.1–41
Metal Gate .....	3.1–43
Metal Gate 14000 Series .....	4.7–1
<b>Communication Circuits</b> .....	4.7–32
Communications Circuits Package Overview .....	4.7–16
Electronic Telephone .....	4.7–16
Audio Control Circuit .....	4.7–16
Dial Circuits .....	4.7–16
The Complete Electronic Telephone Circuit .....	4.7–11
ISDN Voice/Data Circuits .....	4.7–13
Dual Data Link Controller .....	4.7–11
Integrated Services Digital Network .....	4.7–12
S/T-Interface Transceivers .....	4.7–12
U-Interface Transceiver .....	4.7–6
Narrowband FM Receiver .....	4.7–30
Phase-Locked-Loop Components .....	4.7–31
Additional Phase-Locked-Loop Functions .....	4.7–31
Control Functions .....	4.7–31
Oscillators .....	4.7–31
Phase Detectors .....	4.7–31
Prescalers/Counters .....	4.7–30
Intended Applications .....	4.7–30
PLL Frequency Synthesizers .....	4.7–2
RF Communications .....	4.7–3
Balanced Modulator/Demodulator .....	4.7–2
Narrowband Dual Conversion Receivers — FM/FSK — VHF .....	4.7–2
Narrowband Single Conversion Receivers — VHF .....	4.7–3
Transmitters — AM/FM/FSK .....	4.7–2
Wideband (FM/FSK) IFs .....	4.7–2
Wideband Single Conversion Receivers — VHF .....	4.7–20
Speakerphone .....	4.7–23
The Motorola Family of Speakerphone .....	4.7–20, 4.7–22
Integrated Circuits .....	4.7–21
Voice Switched Speakerphone Circuit .....	4.7–21
Voice Switched Speakerphone with $\mu$ Processor Interface .....	4.7–18
Speech Networks .....	4.7–19
Speech Network with Dialer Interface .....	4.7–7
Telephone Speech Network with Dialer Interface .....	4.7–8
Telecommunications .....	4.7–11
PBX Architecture (Analog Transmission) .....	4.7–8
Crosspoint Switches .....	4.7–11
Dual Tone Multiple Frequency Receiver .....	4.7–8
PCM Mono-Circuits Codec-Filters (CMOS LSI) .....	4.7–7
Subscriber Loop Interface Circuits (SLIC) .....	4.7–24
Telephone Accessory Circuits .....	4.7–25
300 Baud FSK Modems .....	4.7–25
ADPCM Transcoder .....	4.7–24
Audio Amplifier .....	4.7–25
Bit Rate Generators .....	4.7–26
Calling Line ID Receiver Evaluation Kit .....	4.7–26
Calling Line Identification (CLID) Receiver with Ring Detector .....	4.7–27
Continuously Variable Slope Delta (CVSD) Modulator/Demodulator .....	4.7–24
Current Mode Switching Regulator .....	4.7–28
Summary of Bipolar Telecommunications Circuits .....	4.7–17
Tone Ringers .....	4.7–6
UHF, FM/AM Transmitter .....	4.7–14
Voice/Data Communication (Digital Transmission) .....	4.7–15
2-Wire ISDN Universal Digital Loop Transceiver II (UDLT II) .....	4.7–14
2-Wire Universal Digital Loop Transceiver (UDLT) .....	

8

# Subject Index

## C (continued)

<b>Communication Circuits</b> (continued)	
Data Set Interface Circuit (DSI)	4.7-15
Wideband FM IF	4.7-4
Wideband FM IF System	4.7-5
<b>Consumer Electronic Circuits</b>	4.8-1
Consumer Electronic Circuits Package Overview	4.8-26
Entertainment Radio Receiver Circuits	4.8-2
Audio Amplifiers	4.8-2
Audio Attenuator	4.8-2
C-Quam AM Stereo Decoders	4.8-2
Entertainment Receiver RF/IF	4.8-2
Remote Control Circuits	4.8-25
Amplifier/Detector (Bipolar)	4.8-25
CMOS Remote Control Functions	4.8-25
Remote Control Application 40 kHz Carrier	4.8-25
Transmitter (CMOS)	4.8-25
Video Circuits	4.8-3
1.3 GHz Tuner PLL with 3-Wire Control	4.8-19
1.3 GHz Tuner PLL with I <sup>2</sup> C Control	4.8-18
Advanced NTSC Comb Filter	4.8-22
Advanced PAL/NTSC Comb Filter	4.8-23
Advanced PAL/NTSC Encoder	4.8-9
Chroma 4 Family Block Diagram	4.8-6
Closed-Caption Decoder	4.8-21
Comb Filters	4.8-4
Composite Video Overlay Synchronizer	4.8-8
Decoders	4.8-3
Deflection	4.8-3
Digital Chroma Delay Line	4.8-13
Digitally Controlled Video Processor for Multimedia Applications	4.8-11
Dual Video Amplifiers	4.8-24
Encoders	4.8-3
IF Circuits	4.8-4
Miscellaneous	4.8-5
Modulators	4.8-4
Monitor Subsystem	4.8-4
Multistandard Video IF	4.8-17
Multistandard Video/Timebase Processor	4.8-10
Pixel Clock Generator and Sync Separator	4.8-15
PLL Tuning Circuit with DACs for Tuner Alignment	4.8-20
Sound	4.8-5
Subcarrier Reference	4.8-14
Television Subsystems	4.8-4
Triple 8-Bit A/D Converter	4.8-16
Triple 8-Bit D/A Converter	4.8-15
Tuner PLL Circuits	4.8-4
TV Stereo Decoder for NICAM and German System	4.8-12
Video Capture Chip Sets	4.8-3
Video Data Converters	4.8-4
Video Input Processing	4.8-7
Video Output Processing	4.8-7
<b>Converters, Digital Signal Processors</b>	2.1-1
Analog-To-Digital	2.1-6

## D

<b>D<sup>2</sup>PAK</b>	5.4-7, 5.6-5
Rectifiers	5.6-5, 5.6-11
TMOS Power MOSFETs	5.4-7, 5.4-15
<b>Data Conversion</b>	4.5-1
A-D Converters	4.5-2
Bipolar	4.5-2
CMOS	4.5-2

## D (continued)

<b>Data Conversion</b> (continued)	
A-D/D-A Converters	4.5-3
CMOS — For Telecommunications	4.5-3
D-A Converters	4.5-3
Bipolar	4.5-3
CMOS	4.5-3
Data Conversion Package Overview	4.5-4
<b>Design-NET — Motorola Data On-Line</b>	7.1-1
<b>Development Tools</b>	
Digital Signal Processors	2.1-1
Design-In Software	2.1-8
LonWorks Products	2.6-1, 2.6-2
Developer's Workbench	2.6-5
Support Tools	2.6-6
<b>Discrete Products</b>	5.0-1
<b>DO-204AA (DO-7)</b>	
Tuning and Switching Diodes, Small Signal	5.1-26, 5.1-32
Zener Diodes	5.2-31
<b>DO-204AH (DO-35), Zener Diodes</b>	5.2-16, 5.2-31
<b>DPAK</b>	5.4-6, 5.5-12, 5.6-5, 5.7-3
Bipolar Power Transistors	5.5-12
Rectifiers	5.6-5, 5.6-11
Thyristors	5.7-3
TMOS Power MOSFETs	5.4-6, 5.4-15

## E

<b>Emitters and Detectors, Optoelectronic Devices</b>	5.8-1, 5.8-14
---	---------------

## F

<b>Fiber Optics, Optoelectronic Devices</b>	5.8-1, 5.8-16
<b>Field-Effect Transistors</b>	5.1-1, 5.1-20, 5.4-1
JFETs, Small Signal	5.1-20
MOSFETs, Small Signal	5.1-22
Power MOSFETs	5.4-1
Surface Mount FETs, Small Signal	5.1-23

## H

<b>HDTMOS Power MOSFETs</b>	
High Power	
D <sup>2</sup> PAK	5.4-3
DPAK	5.4-3
TO-220	5.4-3
SO-8	5.4-3
<b>High Cell Density (Power MOSFETs)</b>	5.4-3
<b>HTL/DTL Circuits</b>	3.1-54
<b>Hybrid Power Modules</b>	5.3-2
Integrated Power Stage IGBTs	5.3-2

## I

<b>ICePAK Multiple Chip Packages</b>	5.4-21
<b>IGBTs</b>	5.3-2, 5.4-23
Hybrid Power Modules	5.3-2
Power MOSFETs	5.4-23
<b>Ignition IGBTs, TMOS Power MOSFETs</b>	5.4-23
<b>Industrial Control Unit</b>	3.1-9
<b>Insulated Gate Bipolar Transistors</b>	5.3-2, 5.4-23
Integrated Power Stage IGBTs, Hybrid Power Modules	5.3-2
TMOS	5.4-23
<b>Interface Circuits</b>	4.6-1
CMOS Display Drivers	4.6-8
Display Drivers	4.6-8

# Subject Index

## I (continued)

<b>Interface Circuits (continued)</b>	
CMOS Display Drivers (continued)	
Functions	4.6-9
Enhanced Ethernet Serial Transceiver (EEST)	4.6-2
High Performance Decoder Driver/Sink Driver	4.6-3
Interface Package Overview	4.6-10
ISO 8802-3 [IEEE 802.3] 10BASE-T Transceiver	4.6-3
Line Drivers	4.6-6
360/370 I/O Interface	4.6-6
EIA Standard	4.6-6
EIA-232-D/V.28 CMOS Drivers/Receivers	4.6-7
General Purpose	4.6-6
IEEE 802.3 Transceivers	4.6-8
Line Transceivers	4.6-7
Peripheral Drivers	4.6-7
Line Receivers	4.6-5
EIA Standard	4.6-5
General Purpose	4.6-5
Microprocessor Bus Interface	4.6-4
Address and Control Bus Extenders	4.6-4
Hex 3-State Buffers/Inverters	4.6-4
Magnetic Read/Write	4.6-4
Microprocessor Data Bus Extenders	4.6-4
Single-Ended Bus Transceivers	4.6-5
For High-Current Party-Line Bus for Industrial and Data Communications	4.6-5
For Instrumentation Bus, Meets GPIB/IEEE Standard 488	4.6-5

## L

<b>Leadform Options, Discrete</b>	
ICePAK Leadform Options	5.13-10
TO-220 (Case 221)	5.13-5
TO-225AA (Case 77)	5.13-2
TO-92 (Case 29)	5.13-2
<b>Logic Integrated Circuits</b>	
Motorola Logic Families, Which Is Best for You?	3.1-3
Numeric Listings	3.1-22
Selection by Function	3.1-11
Special Logic Circuits	3.1-7
<b>Logic Level Power MOSFETs</b>	5.4-18, 5.4-19, 5.4-20
<b>Logic Literature Listing</b>	3.1-64

## M

<b>MECL</b>	3.1-34
ECLinPS	3.1-39
ECLinPS Lite	3.1-40
MECL 10H	3.1-37
MECL 10K	3.1-35
<b>MECL III</b>	3.1-54
<b>Medium Power MOSFETs, TMOS</b>	5.4-5, 5.4-14
<b>Memory Support</b>	3.1-9
<b>Mfax - Touch-Tone FAX for Technical Data</b>	7.1-1
<b>Microcomputer Components</b>	
Fuzzy Logic	2.5-43
M68000 Family	
Coprorocessors	2.2-9
Data Communication Devices	2.2-10
Development Tools	2.2-12
DMA Controllers	2.2-9
Embedded Controllers	2.2-5
Fiber Distributed Data Interface	2.2-11

## M (continued)

<b>Microcomputer Components (continued)</b>	
M68000 Family (continued)	
General Purpose I/O	2.2-11
Integrated Processors	2.2-7
Microprocessors	2.2-1, 2.2-2
Network Devices	2.2-9
Software Support	2.2-12
M88000 RISC Family	2.3-1
Cache/Memory Management Units	2.3-3
Microprocessors	2.3-2
Microcontroller Development Tools	2.5-39
MOS Memories	2.7-1
Dynamic RAMs	2.7-5
DRAM Memory Cards	2.7-7
Flash Modules	2.7-6
General Memory Products	2.7-6
HCMOS	2.7-6
Modules	2.7-5
PCMCIA Flash Cards	2.7-7
Fast Static RAMs	2.7-2
Application Specific	2.7-2
BiCMOS	2.7-3
CMOS	2.7-3
Modules	2.7-4
On-Line Help	2.5-43
PowerPC RISC Family	2.4-1
MPC601 RISC Microprocessor	2.4-2
MPC603 RISC Microprocessor	2.4-4
Single-Chip Microcontrollers (MCU)	2.5-1
M6800 Series Microprocessors and Peripherals	2.5-27
M68300 Family	2.5-36
M68HC05 CSIC Family	2.5-2
M68HC08 Family	2.5-18
M68HC11 Family	2.5-19
M68HC16 Family	2.5-31
MC68HC05 Microcontrollers	2.5-7
Modular Microcontrollers	2.5-29
One-Time Programmable (OTP) / Emulator MCUs	2.5-13
Third-Party Support	2.5-44
<b>Mini Mosorb</b>	5.2-2
Transient Voltage Suppressors	5.2-2
<b>MiniMOS Products</b>	5.4-3, 5.4-4, 5.4-14
<b>MOSFETs, Power, TMOS</b>	5.4-1
<b>Mosorb</b>	5.2-6
Transient Voltage Suppressors	5.2-6
<b>Motorola Device Classification, Discrete</b>	5.0-2
<b>Multiple Chip Packages, ICePAK</b>	5.4-21
<b>Multiple Chip Power Module Devices, ICePAK</b>	5.4-21
<b>O</b>	
<b>Optoelectronic Devices</b>	5.8-1
Emitters and Detectors	5.8-1, 5.8-14
Fiber Optics	5.8-1, 5.8-16
Optointerrupters	5.8-1, 5.8-15
Optoisolators	5.8-1, 5.8-2, 5.8-5
POWER OPTO Isolators	5.8-1, 5.8-13
<b>Optointerrupters, Optoelectronic Devices</b>	5.8-1, 5.8-15
<b>Optoisolators</b>	5.8-1, 5.8-2
<b>Other Linear Circuits</b>	
Multipliers	4.10-2
Linear Four-Quadrant Multipliers	4.10-2
Other Linear Circuits Package Overview	4.10-4

# Subject Index

## O (continued)

### Other Linear Circuits (continued)

Smoke Detectors (CMOS) .....	4.10-3
Timing Circuits .....	4.10-2
Duals .....	4.10-2
Singles .....	4.10-2

## P

### Packaging Specifications, Discrete

Adhesion Pull Tests .....	5.12-9
Fan Fold Box Styles .....	5.12-9
Reel Styles .....	5.12-10
TO-92 EIA Radial Tape .....	5.12-7

### Phase-Locked Loop

Counters .....	3.1-9
Detectors .....	3.1-10
Mixers .....	3.1-10
Multivibrators .....	3.1-10
Oscillators .....	3.1-10
Prescalers .....	3.1-9

### Power MOSFETs, TMOS

.....	5.4-1
-------	-------

### POWER OPTO Isolators

.....	5.8-1, 5.8-13
-------	---------------

### Power Supply Circuits

Linear Voltage Regulators .....	4.2-2
Adjustable Output .....	4.2-5
Fixed Output .....	4.2-2
MOSFET Drivers .....	4.2-17
High Speed Dual Drivers .....	4.2-17
Inverting .....	4.2-17
Noninverting .....	4.2-17

### Power Supervisory Circuits

Microprocessor Voltage Regulator and Supervisory Circuit .....	4.2-16
Over/Undervoltage Protection Circuit .....	4.2-14
Overvoltage Crowbar Sensing Circuit .....	4.2-14
Undervoltage Sensing Circuit .....	4.2-15
Universal Voltage Monitor .....	4.2-16

### Special Regulators

Microprocessor Voltage Regulator/Supervisory Circuit .....	4.2-6
SCSI Regulator .....	4.2-6
Special Switching Regulator Controllers .....	4.2-11
Dual Channel Current Mode Controllers .....	4.2-11
Power Factor Controllers .....	4.2-12
Universal Microprocessor Power Supply Controller .....	4.2-11

### Switching Regulator Control Circuits

Double-Ended Controllers .....	4.2-10
Single-Ended Controllers .....	4.2-7

### Power/Motor Control Circuits

Motor Controllers .....	4.3-1
Brushless DC Motor Controllers .....	4.3-4
Closed-Loop Brushless Motor Adapter .....	4.3-8
DC Servo Motor Controller/Driver .....	4.3-7
Stepper Motor Driver .....	4.3-9
Triac Phase Angle Controller .....	4.3-11
Universal Motor Speed Controllers .....	4.3-10
Power Controllers .....	4.3-2
High-Side Driver Switch .....	4.3-3
Zero Voltage Controller .....	4.3-3
Zero Voltage Switches .....	4.3-2

### POWERTAP II, Rectifiers

.....	5.6-10, 5.6-13
-------	----------------

### Preferred Devices, Motorola, Discrete

.....	5.0-2
-------	-------

### Processors, Digital Signal Processors

16-Bit .....	2.1-1
.....	2.1-2

## P (continued)

### Processors, Digital Signal Processors (continued)

24-Bit .....	2.1-3
32-Bit .....	2.1-4
Peripherals .....	2.1-5

## R

### Rectifier Numbering System

.....	5.6-2
-------	-------

### Rectifiers

Application Specific .....	5.6-3
Automotive Transient Suppressors .....	5.6-3
Low $V_F$ Schottky .....	5.6-3
MEGAHERTZ Rectifiers .....	5.6-3
SCANSWITCH Rectifiers .....	5.6-3
Fast Recovery .....	5.6-14
General Purpose Rectifiers .....	5.6-14
SWITCHMODE Rectifiers .....	5.6-4
Axial Lead Schottky .....	5.6-6
POWERTAP II .....	5.6-10
SOT-227B .....	5.6-10
Surface Mount Schottky .....	5.6-4
TO-204AA, DO-203AA and DO-203AB Schottky Metal Packages .....	5.6-9
TO-218 Types and TO-247 Schottky .....	5.6-8
TO-220 Type Schottky .....	5.6-7
Ultrafast Rectifiers .....	5.6-11
Axial Lead .....	5.6-11
POWERTAP II .....	5.6-13
SOT-227B .....	5.6-13
Surface Mount .....	5.6-11
TO-218 Types .....	5.6-13
TO-220 Type .....	5.6-12
TO-247 .....	5.6-13

### RF Amplifiers

High Power .....	5.10-23
Land Mobile/Portable .....	5.10-25
TV Transmitters .....	5.10-26
Low Power .....	5.10-27
CATV Distribution .....	5.10-27
CRT Drivers .....	5.10-30

### RF Discrete Transistors

Linear Transistors .....	5.10-12
Microwave Transistors .....	5.10-10
RF Power Bipolar Transistors .....	5.10-6
HF Transistors .....	5.10-6
VHF Transistors .....	5.10-6
RF Power MOSFETs .....	5.10-2, 5.10-4
UHF Transistors .....	5.10-7
1.5 GHz Transistors .....	5.10-10
900 MHz Transistors .....	5.10-8

### RF Integrated Circuits

To 1.0 GHz .....	5.10-21
To 1.8 GHz .....	5.10-22

### RF Products

.....	5.10-1
-------	--------

### RF Small Signal Bipolar Transistors

.....	5.10-14
-------	---------

## S

### SC-59

Bipolar Transistors, Small Signal .....	5.1-11
Switching Diodes, Small Signal .....	5.1-35

### SC-70/SOT-323

Bipolar Transistors, Small Signal .....	5.1-11
RF .....	5.10-17





# Subject Index

## S (continued)

<b>SC-70/SOT-323 (continued)</b>	
Switching Diodes, Small Signal	5.1-35
<b>SCSI Bus Terminators</b>	3.1-9
<b>Semiconductor Application Specific Integrated Circuits</b>	1.0-1, 1.1-1
Advanced Packaging	1.1-7
MicroCool Quad Flat Pack	1.1-7
Over-Molded Pad Array Carrier (OMPAC)	1.1-7
Quad Flat Pack Molded Carrier Ring (QFP-MCR)	1.1-7
ASIC Preview	1.1-1
ASIC Regional Design Centers — United States	1.1-8
ASIC Regional Design Centers — International	1.1-8
Bipolar	1.1-2
ECL & ETL Series Arrays	1.1-2
ETL Series Arrays Extend Design Flexibility	1.1-2
ETL Series Features Mixed ECL-TTL Interface	1.1-2
Third Generation	1.1-2
CMOS	1.1-3
1.0 Micron CMOS HDC Series	1.1-3
CDA Architecture	1.1-4
Mixed 3.3 V/5.0 V Levels	1.1-5
Sub-Micron CMOS H4C Series	1.1-4
Sub-Micron CMOS H4CPlus Series	1.1-5
Triple-Layer Metal	1.1-3
Design Automation Software	1.1-6
OACS 2.2 and 3.1M Features	1.1-6
Open Architecture CAD System	1.1-6
Literature	1.1-8
<b>Sensors</b>	5.9-1
Pressure	5.9-2
Compensated and Calibrated	5.9-4, 5.9-9
High Impedance	5.9-4, 5.9-10
Signal Conditioned (On-Chip)	5.9-4, 5.9-10
Uncompensated	5.9-4, 5.9-8
Temperature	5.9-4, 5.9-12
<b>Small Signal Bipolar Transistors, RF</b>	5.10-14
<b>Small Signal Transistors</b>	5.1-1, 5.1-2
Bipolar Transistors	5.1-2
Metal-Can	5.1-17
Plastic-Encapsulated	5.1-2, 5.1-8, 5.1-10
<b>Small Signal Tuning and Switching Diodes</b>	5.1-1, 5.1-25
Abrupt Junction	5.1-25
Hot Carrier (Schottky)	5.1-33
Hyper-Abrupt Junction	5.1-29
Multiple Switching	5.1-37
Switching	5.1-34
<b>SMARTDISCRETES Products</b>	5.4-23
Ignition IGBTs	5.4-23
TO-220AB	5.4-23
<b>SMB</b>	5.2-10, 5.6-4
Rectifiers	5.6-4, 5.6-11
TVS/Zeners	5.2-10, 5.2-21
<b>SMC</b>	5.2-13, 5.6-4
Rectifiers	5.6-4, 5.6-11
Transient Voltage Suppressors	5.2-13
<b>SO-14, Discrete</b>	5.1-38
Multiple Switching Diodes, Small Signal	5.1-38
<b>SO-16, Discrete</b>	
Bipolar Transistors, Small Signal	5.1-9
Multiple Switching Diodes, Small Signal	5.1-38
<b>SO-8, Discrete</b>	5.4-3, 5.10-17
Optoisolators	5.8-12

## S (continued)

<b>SO-8, Discrete (continued)</b>	
RF	5.10-17
TMOS Power MOSFETs	5.4-3, 5.4-4, 5.4-14
<b>SO-8/SO-16, Discrete</b>	5.10-20
RF ICs	5.10-20
<b>SOD-123</b>	5.2-26, 5.6-4
Rectifiers	5.6-4
TVS/Zeners	5.2-21, 5.2-26
<b>SOT-143</b>	5.10-17
RF	5.10-17
<b>SOT-223</b>	
Bipolar Transistors, Small Signal	5.1-15
FETs, Small Signal	5.1-24
Tuning and Switching Diodes, Small Signal	5.1-32
<b>SOT-227B</b>	5.4-22, 5.6-10
Rectifiers	5.6-10, 5.6-13
TMOS Power MOSFETs	5.4-22
<b>SOT-23</b>	5.2-24, 5.10-16
Bipolar Transistors, Small Signal	5.1-10
FETs, Small Signal	5.1-23
Hot-Carrier (Schottky) Diodes, Small Signal	5.1-33
RF	5.10-16
Switching Diodes, Small Signal	5.1-36
Tuning Diodes, Small Signal	5.1-28
TVS/Zeners	5.2-9, 5.2-24
<b>Special Logic Circuits</b>	3.1-22
ALEXIS — Advanced Low-Power Expandable Interface Solutions	3.1-22
Bounce Eliminator	3.1-24
CBM	3.1-23
Industrial Control Unit	3.1-24
Memory Support	3.1-23
Phase-Locked Loop	3.1-24
SCSI Bus Terminators	3.1-23
Timing Solutions	3.1-22
Clock Drivers	3.1-22
Programmable Delay Chips	3.1-23
Transistors	3.1-23
<b>Surface Mount Information, Discrete</b>	
<b>Footprints for Soldering</b>	
D <sup>2</sup> PAK	5.11-5
DPAK	5.11-5
OPTO SO-8	5.11-5
SC-59	5.11-5
SC-70/SOT-323	5.11-5
SMB	5.11-5
SMC	5.11-5
SO-14	5.11-5
SO-16	5.11-5
SO-8	5.11-5
SOD-123	5.11-5
SOT-143	5.11-5
SOT-223	5.11-5
SOT-23	5.11-5
Using Surface Mount Packages	5.11-2
<b>Surface Mount Products, Discrete</b>	5.1-9, 5.2-9, 5.4-4, 5.5-12, 5.6-4, 5.7-3, 5.8-4, 5.10-17
Bipolar Power Transistors	5.5-12
DPAK	5.5-12
Optoisolators	5.8-5
6-Pin Devices	5.8-5, 5.8-9
SO-8	5.8-12
Rectifiers	5.6-4
D <sup>2</sup> PAK	5.6-5, 5.6-11

# Subject Index

## S (continued)

### Surface Mount Products, Discrete (continued)

Rectifiers (continued)	
DPAK	5.6-5, 5.6-11
SMB	5.6-4, 5.6-11
SMC	5.6-4, 5.6-11
RF	5.10-17
SC-70/SOT-323	5.10-17
SO-8	5.10-17
SO-8/SO-16 RF ICs	5.10-20
SOT-143	5.10-17
SOT-23	5.10-16
SC-59	5.1-11, 5.1-35
Small Signal	5.1-9
SC-70/SOT-323	5.1-11, 5.1-35
SO-16	5.1-9
SOT-223	5.1-16, 5.1-24
SOT-23	5.1-10, 5.1-23, 5.1-35, 5.1-36
Thyristors	5.7-3
DPAK	5.7-3
SOT-223	5.7-7
TMOS Power MOSFETs	5.4-4
D <sup>2</sup> PAK	5.4-7, 5.4-15
DPAK	5.4-6, 5.4-15
SO-8	5.4-4, 5.4-14
SOT-223	5.4-5, 5.4-14
TVS/Zeners	5.2-9
SMB	5.2-10, 5.2-21
SMC	5.2-13
SOD-123	5.2-21, 5.2-26
SOT-23	5.2-9, 5.2-21, 5.2-24
<b>Surface Mount Technology</b>	4.11-1
Analog MPQ Table	4.11-8
Tape/Reel and Ammo Pack	4.11-8
PLCC	4.11-8
SOIC	4.11-8
TO-92	4.11-8
Linear and Interface	4.11-2
Bipolar	4.11-2
MOS Digital-Analog	4.11-6
A/D and D/A Converters	4.11-6
Display Drivers	4.11-6
Operational Amplifiers/Comparators	4.11-6
Phase-Locked-Loop Frequency Synthesizers	4.11-6
Remote Control Functions	4.11-7
Smoke Detectors	4.11-7
Telecommunications Devices	4.11-7
Surface Mount Technology Package Overview	4.11-8
Tape and Reel, Logic and Analog Technologies and MOS Integrated Circuits	4.11-9
<b>Surmetic 30</b>	5.2-18
Zener Diodes	5.2-18
<b>Surmetic 40</b>	5.2-18
Transient Voltage Suppressors	5.2-4, 5.2-18
<b>SWITCHMODE Rectifiers</b>	
Axial Lead Schottky	5.6-6
POWER TAP II	5.6-10
SOT-227B	5.6-10
Surface Mount Schottky	5.6-4
TO-204AA, DO-203AA and DO-203AB Schottky Metal Packages	5.6-9
TO-218 Types and TO-247 Schottky	5.6-8
TO-220 Type Schottky	5.6-7

## T

<b>Tape and Reel Specifications, Discrete</b>	5.12-2
Embossed Tape and Reel Data	5.12-4
Embossed Tape and Reel Ordering Information	5.12-3
Lead Tape Packaging Specifications for Axial-Lead Components	5.12-6
<b>Technical Data and Literature</b>	7.1-2, 7.1-5
<b>Technical Data Services</b>	
Design-NET - Motorola Data On-Line	7.1-1
Mfax - Touch-Tone FAX	7.1-1
Semiconductor Data Update Magazine	7.1-1
<b>Technical Training</b>	7.1-6
Audio Cassette Courses	7.1-9
Technical Training Centers	7.1-8
Video Training	7.1-10
<b>Thyristors</b>	5.7-2
Optically Isolated TRIACs	5.7-16
TRIAC Driver/TRIAC Combinations	5.7-16
Silicon Controlled Rectifiers	5.7-2
General Purpose, Metal/Plastic	5.7-2
TRIACs	5.7-7
General Purpose, Metal/Plastic	5.7-7
Triggers	
Programmable Unijunction Transistors	5.7-17
SIDACs	5.7-17
Silicon Bidirectional Switch	5.7-17
<b>Timing Solutions</b>	3.1-7
Clock Drivers	3.1-7
Programmable Delay Chips	3.1-8
<b>TMOS MOSFETs</b>	5.1-22
Small Signal	5.1-22
<b>TMOS Power MOSFETs (See Power MOSFETs)</b>	5.4-1
<b>TMOS Power MOSFETs Numbering System</b>	5.4-2
<b>TMOS V</b>	5.4-24
<b>TO-116</b>	
Bipolar Transistors, Small Signal	5.1-9
Multiple Switching Diodes, Small Signal	5.1-38
<b>TO-204AA (TO-3)</b>	5.4-13
TMOS Power MOSFETs	5.4-13, 5.4-17
<b>TO-204AA, DO-203AA, DO-203AB Metal Packages</b>	5.6-9
Rectifiers	5.6-9
<b>TO-205AD (TO-39)</b>	5.1-17
Bipolar Transistors, Small Signal	5.1-17
<b>TO-206AA (TO-18)</b>	5.1-17
Bipolar Transistors, Small Signal	5.1-17
<b>TO-218</b>	5.6-8
Bipolar Power Transistors	5.5-7
Rectifiers	5.6-8, 5.6-13
<b>TO-220 Isolated</b>	5.4-10
Bipolar Power Transistors	5.5-3
TMOS Power MOSFETs	5.4-10, 5.4-16
<b>TO-220 Types</b>	5.6-7
Rectifiers	5.6-7, 5.6-12
<b>TO-220AB</b>	5.4-8, 5.4-16
Bipolar Power Transistors	5.5-4
Thyristors	5.7-4, 5.7-9
TMOS Power MOSFETs	5.4-8, 5.4-16
<b>TO-225AA</b>	
Bipolar Power Transistors	5.5-10
Thyristors	5.7-3, 5.7-7
<b>TO-226AA (TO-92)</b>	
Bipolar Transistors, Small Signal	5.1-2

# Subject Index

## T (continued)

<b>TO-226AA (TO-92) (continued)</b>	
JFETs, Small Signal	5.1-20
Thyristors	5.7-2
TMOS MOSFETs, Small Signal	5.1-22
Tuning and Switching Diodes, Small Signal	5.1-25, 5.1-28, 5.1-34
<b>TO-226AC (TO-92)</b>	
Hot-Carrier (Schottky) Diodes, Small Signal	5.1-33
Tuning and Switching Diodes, Small Signal	5.1-27, 5.1-31, 5.1-35
<b>TO-226AE (TO-92)</b>	
Bipolar Power Transistors	5.5-19
Bipolar Transistors, Small Signal	5.1-3
TMOS MOSFETs, Small Signal	5.1-22
<b>TO-236AB</b>	
Bipolar Transistors, Small Signal	5.1-10
FETs, Small Signal	5.1-23
Hot-Carrier (Schottky) Diodes, Small Signal	5.1-33
Tuning and Switching Diodes, Small Signal	5.1-31, 5.1-35
<b>TO-247</b>	
Rectifiers	5.6-8, 5.6-13
TMOS Power MOSFETs	5.4-11, 5.4-17
<b>TO-264</b>	
High Power Products	5.4-12
Bipolar Power Transistors	5.5-10
TMOS Power MOSFETs	5.4-12
<b>TO-3PBL</b>	
TMOS Power MOSFETs	5.4-12
<b>Transceivers, Digital Signal Processors</b>	
Digital Audio	2.1-1
<b>Transient Voltage Suppressors</b>	5.2-2
Axial Leaded for Through-hole Designs	5.2-2
<b>Transistors</b>	3.1-8
<b>TTL</b>	3.1-26
FAST	3.1-31
LS - Low Power Schottky	3.1-27

## T (continued)

<b>TVS/Zeners</b>	5.2-1
Transient Voltage Suppressors	5.2-2
General-Purpose	5.2-2
Overvoltage Transient	5.2-15
Surface Mount	5.2-9
Zener Diodes	5.2-16
Current Regulator	5.2-31
Voltage Reference	5.2-31
Voltage Regulator	5.2-16

## U

<b>Ultrafast Rectifiers</b>	5.6-11
Axial Lead	5.6-11
POWERTAP II	5.6-13
SOT-227B	5.6-13
Surface Mount	5.6-11
TO-218 Types	5.6-13
TO-220 Type	5.6-12
TO-247	5.6-13

## V

<b>Voltage References</b>	4.4-1
Precision Low Voltage References	4.4-2

## Z

<b>Zener Diodes</b>	
Current Regulator	5.2-31
Voltage Reference	5.2-31
Voltage Regulator	5.2-16
Axial Leaded for Through-hole Designs	5.2-16
Surface Mount Packages	5.2-21

# Sales Offices and Distributors

---

## In Brief . . .

Motorola's vast network of sales offices and distributors, augmented by manufacturing centers throughout the world, not only ensures easy communications, cost-effective pricing and rapid service, but guarantees a continuing stream of state-of-the-art products based on worldwide experience and demand.

This section identifies for you the Motorola North American Distributors, European Distributors, and Worldwide Sales Offices and their phone numbers.

The information contained in this section is accurate to the date of publication.

	<b>Page</b>
Motorola Distributor and Worldwide Sales Offices . . .	9.1-1



# MOTOROLA DISTRIBUTOR AND WORLDWIDE SALES OFFICES

## AUTHORIZED NORTH AMERICAN DISTRIBUTORS

6/1/94

### UNITED STATES

#### ALABAMA

##### Huntsville

Arrow/Schweber Electronics ..... (205)837-6955  
 Future Electronics ..... (205)830-2322  
 Hamilton Hallmark ..... (205)837-8700  
 Newark ..... (205)837-9091  
 Time Electronics ..... 1-800-789-TIME  
 Wyle Laboratories ..... (205)830-1119

#### Arizona

##### Phoenix

Future Electronics ..... (602)968-7140  
 Hamilton Hallmark ..... (602)437-1200  
 Newark Electronics ..... (602)864-9905  
 Wyle Laboratories ..... (602)437-2088

##### Tempe

Arrow/Schweber Electronics ..... (602)431-0030  
 Time Electronics ..... 1-800-789-TIME

#### CALIFORNIA

##### Agoura Hills

Time Electronics Corporate ..... 1-800-789-TIME

##### Belmont

Richardson Electronics ..... (415)592-9225

##### Calabassas

Arrow/Schweber Electronics ..... (818)880-9686  
 Wyle Laboratories ..... (818)880-9000

##### Chatsworth

Future Electronics ..... (818)865-0040  
 Time Electronics ..... 1-800-789-TIME

##### Costa Mesa

Hamilton Hallmark ..... (714)641-4100

##### Culver City

Hamilton Hallmark ..... (213)558-2000

##### Irvine

Arrow/Schweber Electronics ..... (714)587-0404  
 Future Electronics ..... (714)250-4141  
 Wyle Laboratories Corporate ..... (714)753-9953  
 Wyle Laboratories ..... (714)863-9953

##### Los Angeles

Wyle Laboratories ..... (818)880-9000

##### Mountain View

Richardson Electronics ..... (415)960-6900

##### Orange

Newark ..... (714)634-8224

##### Rocklin

Hamilton Hallmark ..... (916)624-9781

##### Sacramento

Newark ..... (916)721-1633  
 Wyle Laboratories ..... (916)638-5282

##### San Diego

Arrow/Schweber Electronics ..... (619)565-4800  
 Future Electronics ..... (619)625-2800  
 Hamilton Hallmark ..... (619)571-7540  
 Newark ..... (619)569-9877  
 Wyle Laboratories ..... (619)565-9171

##### San Francisco

Newark ..... (415)571-5300

##### San Jose

Arrow/Schweber Electronics ..... (408)441-9700  
 Arrow/Schweber Electronics ..... (408)428-6400  
 Future Electronics ..... (408)434-1122

##### Santa Clara

Wyle Laboratories ..... (408)727-2500

##### Sunnyvale

Hamilton Hallmark ..... (408)435-3500  
 Time Electronics ..... 1-800-789-TIME

##### Torrance

Time Electronics ..... 1-800-789-TIME

##### Tustin

Time Electronics ..... 1-800-789-TIME

##### West Hills

Newark ..... (818)888-3718

#### Woodland Hills

Hamilton Hallmark ..... (818)594-0404  
 Richardson Electronics ..... (615)594-5600

#### COLORADO

##### Lakewood

Future Electronics ..... (303)232-2008

##### Colorado Springs

Newark ..... (719)592-9494

##### Denver

Newark ..... (303)757-3351

##### Englewood

Arrow/Schweber Electronics ..... (303)799-0258  
 Hamilton Hallmark ..... (303)790-1662  
 Time Electronics ..... 1-800-789-TIME

##### Thornton

Wyle Laboratories ..... (303)457-9953

#### CONNECTICUT

##### Cheshire

Future Electronics ..... (203)250-0083  
 Hamilton Hallmark ..... (203)271-2844

##### Southbury

Time Electronics ..... 1-800-789-TIME

##### Wallingford

Arrow/Schweber Electronics ..... (203)265-7741

##### Windsor

Newark ..... (203)683-8860

#### FLORIDA

##### Aitamonte Springs

Future Electronics ..... (407)767-8414

##### Clearwater

Future Electronics ..... (813)530-1222

##### Deerfield Beach

Arrow/Schweber Electronics ..... (305)429-8200  
 Wyle Laboratories ..... (305)420-0500

##### Ft. Lauderdale

Future Electronics ..... (305)436-4043  
 Hamilton Hallmark ..... (305)484-5482  
 Time Electronics ..... 1-800-789-TIME

##### Lake Mary

Arrow/Schweber Electronics ..... (407)333-9300

##### Largo/Tampa/St. Petersburg

Hamilton Hallmark ..... (813)541-7440  
 Newark ..... (813)287-1578  
 Wyle Laboratories ..... (813)576-3004

##### Orlando

Newark ..... (407)896-8350  
 Time Electronics ..... 1-800-789-TIME

##### Plantation

Newark ..... (305)424-4400

##### Winter Park

Hamilton Hallmark ..... (407)657-3300  
 Richardson Electronics ..... (407)644-1453

#### GEORGIA

##### Atlanta

Time Electronics ..... 1-800-789-TIME  
 Wyle Laboratories ..... (404)441-9045

##### Duluth

Arrow/Schweber Electronics ..... (404)497-1300  
 Hamilton Hallmark ..... (404)623-5475

##### Norcross

Future Electronics ..... (404)441-7676  
 Newark ..... (404)448-1300  
 Wyle Laboratories ..... (404)441-9045

#### ILLINOIS

##### Addison

Wyle Laboratories ..... (708)620-0969

##### Bensenville

Hamilton Hallmark ..... (708)860-7780

##### Chicago

Newark Electronics Corp. .... (312)784-5100

##### Hoffman Estates

Future Electronics ..... (708)882-1255

#### Illasca

Arrow/Schweber Electronics ..... (708)250-0500

#### LaFox

Richardson Electronics ..... (708)208-2401

#### Schaumburg

Newark ..... (708)310-8980  
 Time Electronics ..... 1-800-789-TIME

#### INDIANA

##### Indianapolis

Arrow/Schweber Electronics ..... (317)299-2071  
 Hamilton Hallmark ..... (317)872-8875  
 Newark ..... (317)259-0085  
 Time Electronics ..... 1-800-789-TIME

##### Ft. Wayne

Newark ..... (219)484-0766

#### IOWA

##### Cedar Rapids

Newark ..... (319)393-3800  
 Time Electronics ..... 1-800-789-TIME

#### KANSAS

##### Lenexa

Arrow/Schweber Electronics ..... (913)541-9542  
 Hamilton Hallmark ..... (913)888-4747

##### Overland Park

Future Electronics ..... (913)649-1531  
 Newark ..... (913)677-0727  
 Time Electronics ..... 1-800-789-TIME

#### MARYLAND

##### Beltsville

Newark ..... (301)604-1700

##### Columbia

Arrow/Schweber Electronics ..... (301)596-7800  
 Future Electronics ..... (410)290-0600  
 Hamilton Hallmark ..... (410)988-9800  
 Time Electronics ..... 1-800-789-TIME  
 Wyle Laboratories ..... (410)312-4844

#### MASSACHUSETTS

##### Boston

Arrow/Schweber Electronics ..... (508)658-0900

##### Bolton

Future Corporate ..... (508)779-3000

##### Burlington

Wyle Laboratories ..... (617)272-7300

##### Methuen

Newark ..... (508)683-0913

##### Norwell

Richardson Electronics ..... (617)871-5162

##### Peabody

Time Electronics ..... 1-800-789-TIME  
 Hamilton Hallmark ..... (508)532-3701

#### MICHIGAN

##### Detroit

Newark ..... (313)967-0600

##### Grand Rapids

Future Electronics ..... (616)698-6800

##### Livonia

Arrow/Schweber Electronics ..... (313)462-2290  
 Future Electronics ..... (313)261-5270  
 Hamilton Hallmark ..... (313)347-4020  
 Time Electronics ..... 1-800-789-TIME

#### MINNESOTA

##### Eden Prairie

Bloomington ..... (612)853-2280  
 Arrow/Schweber Electronics ..... (612)941-5280  
 Future Electronics ..... (612)944-2200  
 Hamilton Hallmark ..... (612)881-2600  
 Time Electronics ..... 1-800-789-TIME

##### Minneapolis

Newark ..... (612)331-6350



## AUTHORIZED DISTRIBUTORS – continued

### UNITED STATES – continued

#### MISSOURI – continued

**Earth City**  
Hamilton Hallmark ..... (314)291-5350

#### MISSOURI

**St. Louis**  
Arrow/Schweber Electronics ..... (314)567-6888  
Future Electronics ..... (314)469-6805  
Newark ..... (314)298-2505  
Time Electronics ..... 1-800-789-TIME

#### NEW JERSEY

**Cherry Hill**  
Hamilton Hallmark ..... (609)424-0100

**Fairfield**  
Newark ..... (201)882-0300

**Marlton**  
Arrow/Schweber Electronics ..... (609)596-8000  
Future Electronics ..... (609)596-4080

**Pinebrook**  
Arrow/Schweber Electronics ..... (201)227-7880  
Wyle Laboratories ..... (201)882-8358

**Parsippany**  
Future Electronics ..... (201)299-0400  
Hamilton Hallmark ..... (201)515-1641

**Wayne**  
Time Electronics ..... 1-800-789-TIME

#### NEW MEXICO

**Albuquerque**  
Alliance Electronics ..... (505)292-3360  
Hamilton Hallmark ..... (505)828-1058  
Newark ..... (505)828-1878

#### NEW YORK

**Commack**  
Newark ..... (516)499-1216

**Hauppauge**  
Arrow/Schweber Electronics ..... (516)231-1000  
Future Electronics ..... (516)234-4000  
Hamilton Hallmark ..... (516)434-7400

**Konkoma**  
Hamilton Hallmark ..... (516)737-0600

**Melville**  
Wyle Laboratories ..... (516)293-8446

**Pittsford**  
Newark ..... (716)381-4244

**Rochester**  
Arrow/Schweber Electronics ..... (716)427-0300  
Future Electronics ..... (716)272-1120  
Hamilton Hallmark ..... (716)475-9130  
Richardson Electronics ..... (716)264-1100  
Time Electronics ..... 1-800-789-TIME

**Rockville Centre**  
Richardson Electronics ..... (516)872-4400

**Syracuse**  
Future Electronics ..... (315)451-2371  
Time Electronics ..... 1-800-789-TIME

#### NORTH CAROLINA

**Charlotte**  
Future Electronics ..... (704)455-9030  
Richardson Electronics ..... (704)548-9042

**Greensboro**  
Newark ..... (919)292-7240

**Raleigh**  
Arrow/Schweber Electronics ..... (919)876-3132  
Future Electronics ..... (919)790-7111  
Hamilton Hallmark ..... (919)872-0712  
Time Electronics ..... 1-800-789-TIME

#### OHIO

**Centerville**  
Arrow/Schweber Electronics ..... (513)435-5563

**Cleveland**  
Newark ..... (216)391-9330  
Time Electronics ..... 1-800-789-TIME

**Columbus**  
Newark ..... (614)431-0809  
Time Electronics ..... 1-800-789-TIME

**Dayton**  
Future Electronics ..... (513)439-5700

Hamilton Hallmark ..... (513)439-6735  
Newark ..... (513)294-8980  
Time Electronics ..... 1-800-789-TIME

**Mayfield Heights**  
Future Electronics ..... (216)449-6996

**Solon**  
Arrow/Schweber Electronics ..... (216)248-3990  
Hamilton Hallmark ..... (216)498-1100

**Worthington**  
Hamilton Hallmark ..... (614)888-3313

#### OKLAHOMA

**Tulsa**  
Hamilton Hallmark ..... (918)254-6110  
Newark ..... (918)252-5070

#### OREGON

**Beaverton**  
Arrow/Almac Electronics Corp. .... (503)629-8090  
Future Electronics ..... (503)645-9454  
Hamilton Hallmark ..... (503)528-6200  
Wyle Laboratories ..... (503)643-7900

**Portland**  
Newark ..... (503)297-1984  
Time Electronics ..... 1-800-789-TIME

#### PENNSYLVANIA

**King of Prussia**  
Newark ..... (215)265-0933

**Mt. Laurel**  
Wyle Laboratories ..... (609)439-9110

**Montgomeryville**  
Richardson Electronics ..... (215)628-0805

**Philadelphia**  
Time Electronics ..... 1-800-789-TIME  
Wyle Laboratories ..... (609)439-9110

**Pittsburgh**  
Arrow/Schweber Electronics ..... (412)963-6807  
Newark ..... (412)788-4790  
Time Electronics ..... 1-800-789-TIME

#### TENNESSEE

**Franklin**  
Richardson Electronics ..... (615)791-4900

**Knoxville**  
Newark ..... (615)588-6493

#### TEXAS

**Austin**  
Arrow/Schweber Electronics ..... (512)835-4180  
Future Electronics ..... (512)502-0991  
Hamilton Hallmark ..... (512)258-8818  
Newark ..... (512)338-0287  
Time Electronics ..... 1-800-789-TIME  
Wyle Laboratories ..... (512)345-8853

**Carrollton**  
Arrow/Schweber Electronics ..... (214)380-6464

**Dallas**  
Future Electronics ..... (214)437-2437  
Hamilton Hallmark ..... (214)553-4300  
Richardson Electronics ..... (214)239-3680  
Time Electronics ..... 1-800-789-TIME  
Wyle Laboratories ..... (214)235-9953

**Ft. Worth**  
Allied Electronics ..... (817)336-5401

**Houston**  
Arrow/Schweber Electronics ..... (713)530-4700  
Future Electronics ..... (713)785-1155  
Hamilton Hallmark ..... (713)781-6100  
Newark ..... (713)270-4800  
Time Electronics ..... 1-800-789-TIME  
Wyle Laboratories ..... (713)879-9953

**Richardson**  
Newark ..... (214)235-1998

#### UTAH

**Salt Lake City**  
Arrow/Schweber Electronics ..... (801)973-6913  
Future Electronics ..... (801)467-4448  
Hamilton Hallmark ..... (801)266-2022  
Newark ..... (801)261-5660  
Wyle Laboratories ..... (801)974-9953

**West Valley City**  
Time Electronics ..... 1-800-789-TIME  
Wyle Laboratories ..... (801)974-9953

#### WASHINGTON

**Bellevue**  
Almac Electronics Corp. .... (206)643-9992  
Newark ..... (206)641-9800  
Richardson Electronics ..... (206)646-7224

**Bothell**  
Future Electronics ..... (206)489-3400

**Redmond**  
Hamilton Hallmark ..... (206)881-6697  
Time Electronics ..... 1-800-789-TIME  
Wyle Laboratories ..... (206)881-1150

**Seattle**  
Wyle Laboratories ..... (206)881-1150

**Spokane**  
Arrow/Almac Electronics Corp. ... (509)924-9500

#### WISCONSIN

**Brookfield**  
Arrow/Schweber Electronics ..... (414)792-0150  
Future Electronics ..... (414)879-0244

**Milwaukee**  
Time Electronics ..... 1-800-789-TIME

**New Berlin**  
Hamilton Hallmark ..... (414)780-7200

**Wauwatosa**  
Newark ..... (414)453-9100

**Waukesha**  
Wyle Laboratories ..... (414)521-9333

#### CANADA

##### ALBERTA

**Calgary**  
Electro Sonic Inc. .... (403)255-9550  
Future Electronics ..... (403)250-5550  
Hamilton Hallmark ..... (604)420-4101

**Edmonton**  
Future Electronics ..... (403)438-2858  
Hamilton Hallmark ..... (800)663-5500

##### BRITISH COLUMBIA

**Vancouver**  
Arrow Electronics ..... (604)421-2333  
Electro Sonic Inc. .... (604)273-2911  
Future Electronics ..... (604)294-1166  
Hamilton Hallmark ..... (604)420-4101  
Newark ..... (800)463-9275

##### MANITOBA

**Winnipeg**  
Electro Sonic Inc. .... (204)783-3105  
Future Electronics ..... (204)944-1446  
Hamilton Hallmark ..... (800)663-5500

##### ONTARIO

**Ottawa**  
Arrow Electronics ..... (613)226-6903  
Electro Sonic Inc. .... (613)728-8333  
Future Electronics ..... (613)820-8313  
Hamilton/Avnet Electronics ..... (613)226-1700

**Toronto**  
Arrow Electronics ..... (416)670-7769  
Electro Sonic Inc. .... (416)494-1666  
Future Electronics ..... (416)612-9200  
Hamilton Hallmark ..... (905)564-6060  
Newark ..... (800)463-9275  
Richardson Electronics ..... (800)348-5530

##### QUEBEC

**Montreal**  
Arrow Electronics ..... (514)421-7411  
Future Electronics ..... (514)694-7710  
Hamilton Hallmark ..... (514)335-1000  
Newark ..... (800)463-9275  
Richardson Electronics ..... (800)348-5530

**Quebec City**  
Future Electronics ..... (418)877-6666

9

## SALES OFFICES

<b>UNITED STATES</b>		<b>OKLAHOMA</b> , Tulsa ..... (800)544-9496	<b>JAPAN</b> , Kyushu ..... 81-92-771-4212
<b>ALABAMA</b> , Huntsville ..... (205)464-6800		<b>OREGON</b> , Portland ..... (503)641-3681	<b>JAPAN</b> , Nagoya ..... 81-52-232-1621
<b>ALASKA</b> , ..... (800)635-8291		<b>PENNSYLVANIA</b> , Colmar ..... (215)997-1020	<b>JAPAN</b> , Osaka ..... 81-06-305-1801
<b>ARIZONA</b> , Tempe ..... (602)897-5056		Philadelphia/Horsham ..... (215)957-4100	<b>JAPAN</b> , Sendai ..... 81-22-268-4333
<b>CALIFORNIA</b> , Agoura Hills .. (818)706-1929		<b>TENNESSEE</b> , Knoxville ..... (615)690-5593	<b>JAPAN</b> , Tachikawa ..... 81-425-23-6700
<b>CALIFORNIA</b> , Los Angeles ... (310)417-8848		<b>TEXAS</b> , Austin ..... (512)502-2100	<b>JAPAN</b> , Takamatsu ..... 81-878-37-9972
<b>CALIFORNIA</b> , Irvine ..... (714)753-7360		<b>TEXAS</b> , Houston ..... (800)343-2692	<b>JAPAN</b> , Tokyo ..... 81-3-3440-3341
<b>CALIFORNIA</b> , San Diego ... (619)541-2163		<b>TEXAS</b> , Plano ..... (214)516-5100	<b>JAPAN</b> , Yokohama ..... 81-45-472-2751
<b>CALIFORNIA</b> , Sunnyvale ... (408)749-0510		<b>TEXAS</b> , Seguin ..... (210)372-7620	<b>KOREA</b> , Pusan ..... 82(51)4635-035
<b>COLORADO</b> ,		<b>VIRGINIA</b> , Richmond ..... (804)285-2100	<b>KOREA</b> , Seoul ..... 82(2)554-5118
Colorado Springs ..... (719)599-7497		<b>UTAH</b> , CSI @ ..... (801)561-5099	<b>MALAYSIA</b> , Penang ..... 60(4)374514
<b>COLORADO</b> , Denver ..... (303)337-3434		<b>WASHINGTON</b> , Bellevue ... (206)454-4160	<b>MEXICO</b> , Mexico City ..... 52(5)282-0230
<b>CONNECTICUT</b> ,		Seattle Access ..... (206)622-9960	<b>MEXICO</b> , Guadalajara ..... 52(36)21-8977
Wallingford ..... (203)949-4100		<b>WISCONSIN</b> , Milwaukee/	Marketing ..... 52(36)21-2023
<b>FLORIDA</b> , Maitland ..... (407)628-2636		Brookfield ..... (414)792-0122	Customer Service ..... 52(36)669-9160
<b>FLORIDA</b> , Pompano Beach/		Field Applications Engineering Available	<b>NETHERLANDS</b> , Best .... (31)4998 612 11
Ft. Lauderdale ..... (305)351-6040		Through All Sales Offices	<b>PUERTO RICO</b> , San Juan .. (809)793-2170
<b>FLORIDA</b> , Clearwater ..... (813)538-7750			<b>SINGAPORE</b> ..... (65)2945438
<b>GEORGIA</b> , Atlanta ..... (404)729-7100		<b>CANADA</b>	<b>SPAIN</b> , Madrid ..... 34(1)457-8204
<b>IDAHO</b> , Boise ..... (208)323-9413		<b>BRITISH COLUMBIA</b> ,	or ..... 34(1)457-8254
<b>ILLINOIS</b> , Chicago/		Vancouver ..... (604)293-7650	<b>SWEDEN</b> , Solna ..... 46(8)734-8800
Hoffman Estates ..... (708)413-2500		<b>ONTARIO</b> , Toronto ..... (416)497-8181	<b>SWITZERLAND</b> , Geneva ... 41(22)799 11 11
Shauburg ..... (708)413-2500		<b>ONTARIO</b> , Ottawa ..... (613)226-3491	<b>SWITZERLAND</b> , Zurich ... 41(1)730-4074
<b>INDIANA</b> , Fort Wayne ..... (219)436-5818		<b>QUEBEC</b> , Montreal ..... (514)333-3300	<b>TAIWAN</b> , Taipei ..... 886(2)717-7089
<b>INDIANA</b> , Indianapolis ..... (317)571-0400		<b>INTERNATIONAL</b>	<b>THAILAND</b> , Bangkok ..... 66(2)254-4910
<b>INDIANA</b> , Kokomo ..... (317)455-5100		<b>AUSTRALIA</b> , Melbourne ... (61-3)887-0711	<b>UNITED KINGDOM</b> ,
<b>IOWA</b> , Cedar Rapids ..... (319)378-0383		<b>AUSTRALIA</b> , Sydney ..... 61(2)906-3855	Aylesbury ..... 44(296)395-252
<b>KANSAS</b> , Kansas City/		<b>BRAZIL</b> , Sao Paulo ..... 55(11)815-4200	
Mission ..... (913)451-8555		<b>CHINA</b> , Beijing ..... 86-505-2180	
<b>MARYLAND</b> , Columbia ..... (410)381-1570		<b>FINLAND</b> , Helsinki ..... 358-0-351 61191	
<b>MASSACHUSETTS</b> ,		car phone ..... 358(49)211501	
Marlborough ..... (508)481-8100		<b>FRANCE</b> , Paris/Varves .... 33(1)40 955 900	
<b>MASSACHUSETTS</b> ,		<b>GERMANY</b> , Langenhagen/	
Woburn ..... (617)932-9700		Hannover ..... 49(511)789911	
<b>MICHIGAN</b> , Detroit ..... (313)347-6800		<b>GERMANY</b> , Munich ..... 49 89 92103-0	
<b>MINNESOTA</b> , Minnetonka ... (612)932-1500		<b>GERMANY</b> , Nuremberg ... 49 911 96-3190	
<b>MISSOURI</b> , St. Louis ..... (314)275-7380		<b>GERMANY</b> , Sindelfingen ... 49 7031 69 910	
<b>NEW JERSEY</b> , Fairfield ..... (201)808-2400		<b>GERMANY</b> , Wiesbaden .... 49 611 973050	
<b>NEW YORK</b> , Fairport ..... (716)425-4000		<b>HONG KONG</b> , Kwai Fong ... 852-489-1111	
<b>NEW YORK</b> , Hauppauge ... (516)361-7000		Tai Po ..... 852-6668333	
<b>NEW YORK</b> , Fishkill ..... (914)896-0511		<b>INDIA</b> , Bangalore ..... (91-812)627094	
<b>NORTH CAROLINA</b> ,		<b>ISRAEL</b> , Tel Aviv ..... 972(3)753-8222	
Raleigh ..... (919)870-4355		<b>ITALY</b> , Milan ..... 39(2)82201	
<b>OHIO</b> , Cleveland ..... (216)349-3100		<b>JAPAN</b> , Atsugi ..... 81-462-23-0761	
<b>OHIO</b> , Columbus/		<b>JAPAN</b> , Gotanda ..... 81-3-5487-8448	
Worthington ..... (614)431-8492		<b>JAPAN</b> , Kumagaya ..... 81-485-26-2600	
<b>OHIO</b> , Dayton ..... (513)495-6800			



# SALES OFFICES

## INTERNATIONAL MOTOROLA DISTRIBUTOR AND SALES OFFICES

### AUTHORIZED DISTRIBUTORS

**AUSTRALIA**

VSI Electronics (NZ) Ltd ..... (64)9 579-6603  
 VSI Promark Elec. Pty Ltd ..... (61)2 439-4655  
 Veltek Pty Ltd ..... (61)3 808-7511

**AUSTRIA**

EBV Austria ..... (43) 222 894 1774  
 Elbatex GmbH ..... (43) 222 86 3211

**BENELUX**

Diode Belgium ..... (32) 2 725 4660  
 Diode Components BV ..... (31) 340 29 1234  
 EBV Belgium ..... (32) 2 720 9936  
 EBV Holland ..... (31) 3465 623 53  
 Rodelco Electronics ..... (31) 767 84911  
 Rodelco N.V. .... (32) 2 460 0560

**CHINA**

Advanced Electronics Ltd. .... (852)305-3633  
 China El. App. Corp. Xiamen Co. .... (86)592 553-487  
 Nanco Electronics Supply Ltd. .... (852) 333-5121  
 Qing Cheng Enterprises Ltd. .... (852) 493-4202

**DENMARK**

Avnet Nortec A/S Denmark ..... (45) 428 42000  
 EBV Denmark ..... (45) 398 905 11

**FINLAND**

Arrow Field OY ..... (35) 807 775 71

**FRANCE**

Arrow Electronique ..... (33) 1 49 78 49 78  
 Avnet Components ..... (33) 1 49 65 25 00  
 EBV France ..... (33) 1 64 68 86 00  
 Scab ..... (33) 1 46 87 23 13

**GERMANY**

Avnet E2000 ..... (49) 89 4511001  
 EBV Germany ..... (49) 89 456100  
 Future Electronics GmbH ..... (49) 89-957 195-0  
 Jermyn GmbH ..... (49) 6431-5080  
 Muetron, Mueller  
 GmbH & Co. .... (49) 421-305 60  
 Sasco GmbH ..... (49) 89-461110  
 Spoerle Electronic ..... (49) 6103-304-0

**HONG KONG**

Nanshing Cir. & Chem. Co. Ltd ..... (852) 333-5121  
 Wong's Kong King Semi. Ltd. .... (852) 357-8888

**INDIA**

Canyon Products Ltd ..... (852) 755-2583

**ITALY**

Avnet Adelsy SpA ..... (39) 2 38103100

EBV Italy ..... (39) 2 66017111  
 Silverstar SpA ..... (39) 2 66 12 51

**JAPAN**

AMSC Co., Ltd. .... 81-422-54-6800  
 Marubun Corporation ..... 81-3-3639-8951  
 OMRON Corporation ..... 81-3-5488-3121  
 Fuji Electronics Co. Ltd. .... 81-3-3814-1411  
 Tokyo Electron Ltd. .... 81-3-3340-8239  
 Nihon Motorola Micro Elec. .... 81-3-3280-7333

**KOREA**

Lite-On Korea Ltd. .... (82)2 858-3853  
 Lee Ma Industrial Co. Ltd. .... (82)2 739-5257  
 Jung Kwang Sa ..... (82)51 802-2153

**NORWAY**

Avnet Nortec A/S Norway ..... (47) 6 664 6210

**SCANDINAVIA**

ITT Multikomponent AB ..... (46) 8 830 020  
 Avnet Nortec (S) ..... (46) 8 705 1800  
 Avnet Nortec (DK) ..... (45) 42 842 000  
 Avnet Nortec (N) ..... (47) 6 684 210

**SINGAPORE**

Alexan Commercial ..... (63)2 405-952  
 GEIC ..... (65) 298-7633  
 P.T. Ometraco ..... (62)22 630-805  
 Uraco Impex Asia Pte Ltd. .... (65) 284-0622  
 Shaphipat Ltd. .... (66)2 221-5384

**SPAIN**

Amitron Arrow ..... (34) 1 304 30 40  
 EBV Spain ..... (34) 9 358 86 08  
 Selco S.A. .... (34) 1 359 43 48

**SWEDEN**

Avnet Nortec AB ..... (48) 8 629 14 00

**SWITZERLAND**

EBV Switzerland ..... (41) 1 740 10 90  
 Elbatex AG ..... (41) 56 275 165

**TAIWAN**

Mercuries & Assoc. Ltd ..... (886)2 503-1111  
 Solomon Technology Corp. .... (886)2 760-5858  
 Strong Electronics Co. Ltd. .... (886)2 917-9917

**UNITED KINGDOM**

Arrow Electronics (UK) Ltd ..... (44) 234 272733  
 Avnet/Access ..... (44) 462 480888  
 Future Electronics Ltd. .... (44) 753 687000  
 Macro Marketing Ltd. .... (44) 628 604 383

**CANADA****ALBERTA**

Calgary  
 Electro Sonic Inc. .... (403)255-9550  
 Future Electronics ..... (403)250-5550  
 Hamilton/Avnet Electronics ..... (403)236-2484  
 Edmonton  
 Future Electronics ..... (403)438-2858  
 Hamilton/Avnet Electronics ..... (800)663-5500

**BRITISH COLUMBIA**

Vancouver  
 Electro Sonic Inc. .... (609)273-2911  
 Future Electronics ..... (604)294-1166  
 Hamilton/Avnet Electronics ..... (604)420-4101

**MANITOBA**

Winnipeg  
 Electro Sonic Inc. .... (209)783-3105  
 Future Electronics ..... (204)944-1446  
 Hamilton/Avnet Electronics ..... (204)942-3992

**ONTARIO**

Ottawa  
 Arrow Electronics ..... (613)226-6903  
 Electro Sonic Inc. .... (613)728-8333  
 Future Electronics ..... (613)820-8313  
 Hamilton/Avnet Electronics ..... (613)226-1700

Toronto  
 Arrow Electronics ..... (416)670-7769  
 Electro Sonic Inc. .... (416)494-1555  
 Future Electronics ..... (416)638-4771  
 Hamilton/Avnet Electronics ..... (416)677-7432  
 Richardson Electronics ..... (416)458-5333

**QUEBEC**

Montreal  
 Arrow Electronics ..... (514)421-7411  
 Future Electronics ..... (514)694-7710  
 Hamilton/Avnet Electronics ..... (514)335-1000  
 Quebec City  
 Arrow Electronics ..... (418)687-4231  
 Future Electronics ..... (418)682-8092  
 St. Laurent  
 Richardson Electronics ..... (514)748-1770

## SALES OFFICES

**CANADA**

**BRITISH COLUMBIA, Vancouver** ..... (604)293-7650  
**ONTARIO, Toronto** ..... (416)497-8181  
**ONTARIO, Ottawa** ..... (613)226-3491  
**QUEBEC, Montreal** ..... (514)333-3300

**INTERNATIONAL**

**AUSTRALIA, Melbourne** ..... (61-3)887-0711  
**AUSTRALIA, Sydney** ..... 61(2)906-3855  
**BRAZIL, Sao Paulo** ..... 55(11)815-4200  
**CHINA, Beijing** ..... 86-505-2180  
**CHINA, Guangzhou** ..... (86) 20 331-1626  
**CHINA, Shanghai** ..... (86) 21 279-8206  
**CHINA, Singapore** ..... (65) 481-8188  
**CHINA, Tianjin** ..... (86) 22 506-972  
**FINLAND, Helsinki** ..... 358-0-351 61191  
 car phone ..... 358(49)211501  
**FRANCE, Paris/Velizy** ..... 33(1)34 63 59 00  
**GERMANY, Langenhagen/**

Hannover ..... 49(511)789911  
 GERMANY, Munich ..... 49 89 92103-0  
**GERMANY, Nurenberg** ..... 49 911 66-3190  
**GERMANY, Sindelfingen** ..... 49 7031 69 910  
**GERMANY, Wiesbaden** ..... 49 611 973050  
**HONG KONG, Kwai Fong** ..... 852-489-1111  
 Tai Po ..... 852-6668333  
**INDIA, Bangalore** ..... (91-812)627094  
**ISRAEL, Tel Aviv** ..... 972(3)753-8222  
**ITALY, Milan** ..... 39(2)82201  
**JAPAN, Atsugi** ..... 81-462-23-0761  
**JAPAN, Gotanda** ..... 81-3-5487-8448  
**JAPAN, Kumagaya** ..... 81-485-26-2600  
**JAPAN, Kyushu** ..... 81-92-771-4212  
**JAPAN, Nagoya** ..... 81-52-232-1621  
**JAPAN, Osaka** ..... 81-06-305-1801  
**JAPAN, Sendai** ..... 81-22-268-4333  
**JAPAN, Tachikawa** ..... 81-425-23-6700  
**JAPAN, Takamatsu** ..... 81-878-37-9972  
**JAPAN, Tokyo** ..... 81-3-3440-3311

**JAPAN, Yokohama** ..... 81-45-472-2751  
**KOREA, Pusan** ..... 82(51)4635-035  
**KOREA, Seoul** ..... 82(2)554-5118  
**MALAYSIA, Penang** ..... 60(4)374514  
**MEXICO, Mexico City** ..... 52(5)282-0230  
**MEXICO, Guadalajara** ..... 52(36)21-8977  
 Marketing ..... 52(36)21-2023  
 Customer Service ..... 52(36)669-9160  
**NETHERLANDS, Best** ..... (31)498 612 11  
**PHILIPPINES, Manila** ..... (63)2 822-0625  
**PUERTO RICO, San Juan** ..... (809)793-2170  
**SINGAPORE** ..... (65)2945438  
**SPAIN, Madrid** ..... 34(1)457-8204  
 or ..... 34(1)457-8254  
**SWEDEN, Solna** ..... 46(8)734-8800  
**SWITZERLAND, Geneva** ..... 41(22)799 11 11  
**SWITZERLAND, Zurich** ..... 41(1)730-4074  
**TAIWAN, Taipei** ..... 886(2)717-7089  
**THAILAND, Bangkok** ..... 66(2)254-4910  
**UNITED KINGDOM, Aylesbury** ..... 44(296)395-252

9



## **Introduction**

---

**1 Semicustom Application Specific  
Integrated Circuits (ASIC)**

---

**2 Microcomputer Components**

---

**3 TTL, ECL, CMOS and  
Special Logic Circuits**

---

**4 Linear and Interface  
Integrated Circuits**

---

**5 Discrete Products**

---

**6 Military Integrated Circuits  
and Discrete Products**

---

**7 Product Literature and  
Technical Training**

---

**8 Device Index and  
Subject Index**

---

**9 Sales Offices  
and Distributors**

---





Printed on Recycled Paper.

The last edition of this document was produced so it could be recycled. You are encouraged to dispose of your old copies through your company's or local government's recycling program.



**MOTOROLA**

**Literature Distribution Centers:**

USA: Motorola Literature Distribution; P.O. Box 20912; Phoenix, Arizona 85036.

EUROPE: Motorola Ltd.; European Literature Centre; 88 Tanners Drive, Blakelands, Milton Keynes, MK14 5BP, England.

JAPAN: Nippon Motorola Ltd.; 4-32-1, Nishi-Gotanda, Shinagawa-ku, Tokyo 141, Japan.

ASIA PACIFIC: Motorola Semiconductors H.K. Ltd.; Silicon Harbour Center, No. 2 Dai King Street, Tai Po Industrial Estate, Tai Po, N.T., Hong Ko

